

Service Kit 759-04236

Date: February 08, 2010
 Subject: RZT 50"/54" Chute Strap Kit
 Models Affected: 19A70004100 50" Twin Bagger
 19A70004OEM 50" Twin Bagger
 19A70008100 54" Triple Bagger
 19A70008OEM 54" Triple Bagger

PURPOSE: To ensure retention of the Upper Bagger Chute Assembly to the 50"/54" Discharge Elbow Chute Assembly on RZT 50 and RZT 54 Models.

NOTE: These materials are prepared for use by trained technicians who are experienced in the service and repair of equipment of the kind described in this publication, and are not intended for use by untrained or inexperienced individuals. Such individuals should seek the assistance of an authorized service technician or dealer.

NOTE: Save this Instruction Sheet. Refer to it when ordering replacement parts.

759-04236 Service Kit Contents

REF. NO.	PART NUMBER	QTY	DESCRIPTION
1	710-0924	1	Scr:Mach:1/4-20 x .75
2	711-04069	1	Grass Catcher Pin
3	712-0324	1	Nut:Hexlk:1/4-20:GR8:Nylon
4	712-3027	1	Nut:Flgk:1/4-20
5	723-04009A	1	Strap:Chute:11.65 Lg.

Instruction sheet included with kit.

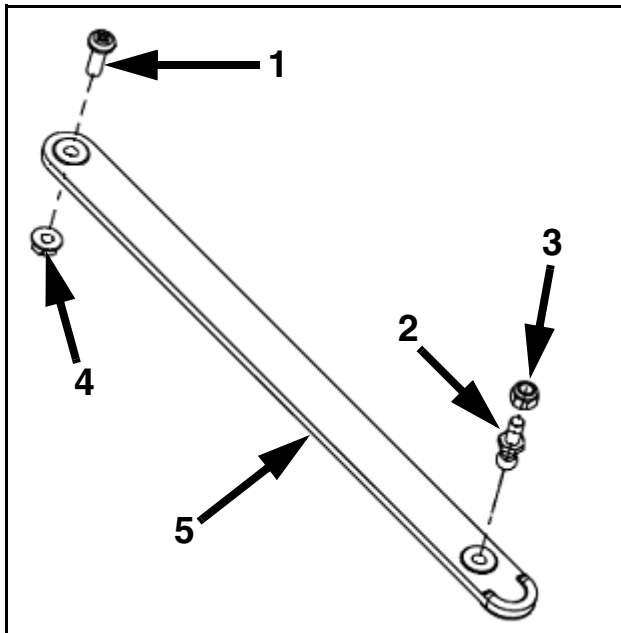

FIGURE 1

PREPARATION INSTRUCTIONS:

1. Check the upper chute assembly (631-04295) to see if the hole is present in the straight portion 1" from the end on the bottom side as shown in Figure 2.

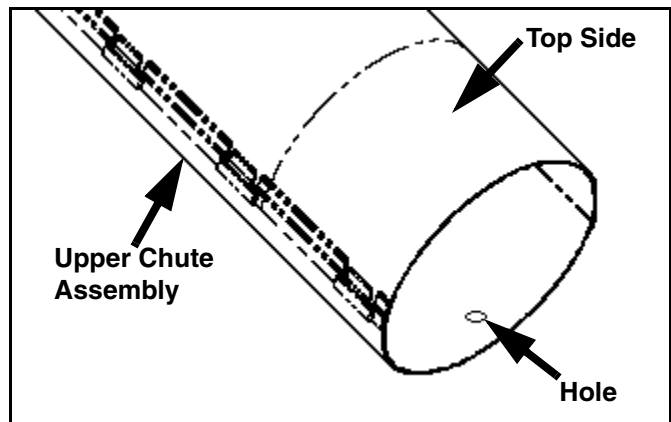

FIGURE 2

2. If not, measure 1" down from the straight portion of the upper chute assembly centered in between the two seams on the side of the upper chute assembly. See Figure 3. Make a mark.

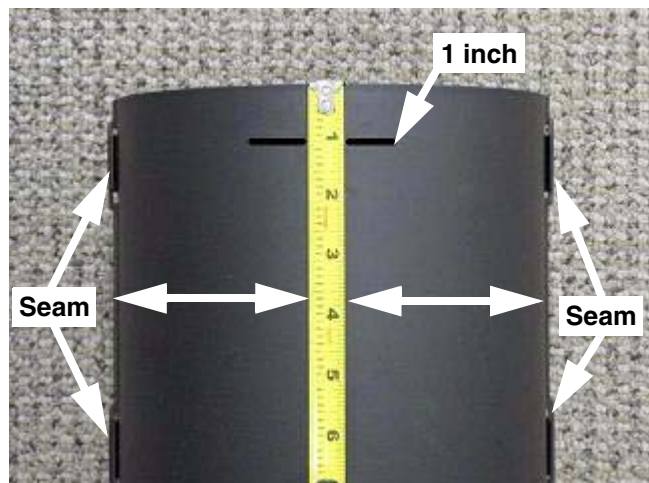

FIGURE 3

3. Drill a hole in the location marked in step 2, using a 9/32" drill bit. See Figure 4.

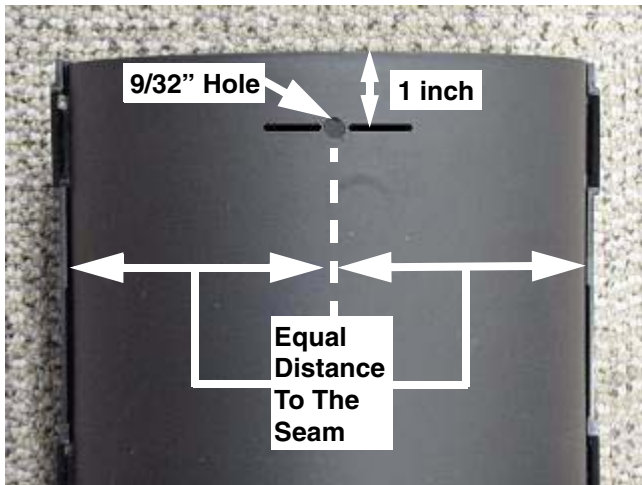

FIGURE 4

5. Check the discharge elbow chute assembly (631-04300) for the hole called out in Figure 5.

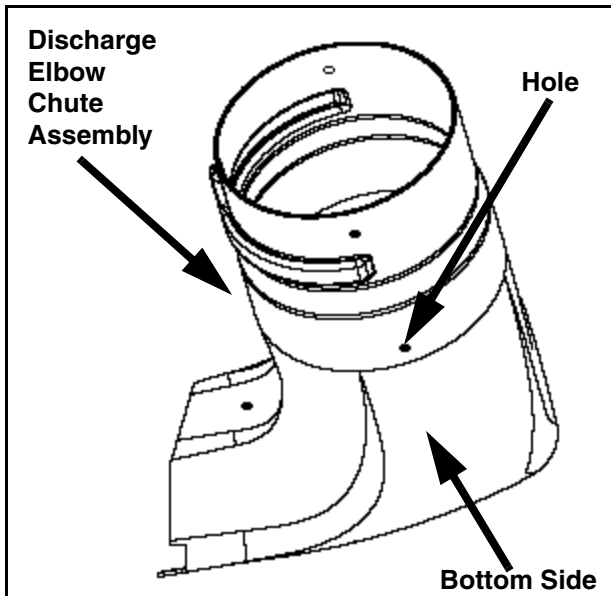

FIGURE 5

6. If the hole called out above in Figure 5 is not present in the discharge elbow chute assembly you will need to drill the bottom side hole for this Service Kit.

7. If the bagger chute adapter is installed on the discharge elbow chute assembly, remove the two (2) ratchet fasteners that secure the bagger chute adapter to the discharge elbow chute assembly. Set the parts removed to the side for re-installation in step 14.

8. Measure down from the tube side on the bottom side of the discharge elbow chute assembly, 6.375" (6 3/8") and make a mark. **NOTE: Use the seam line as a reference guide. See Figure 6.**

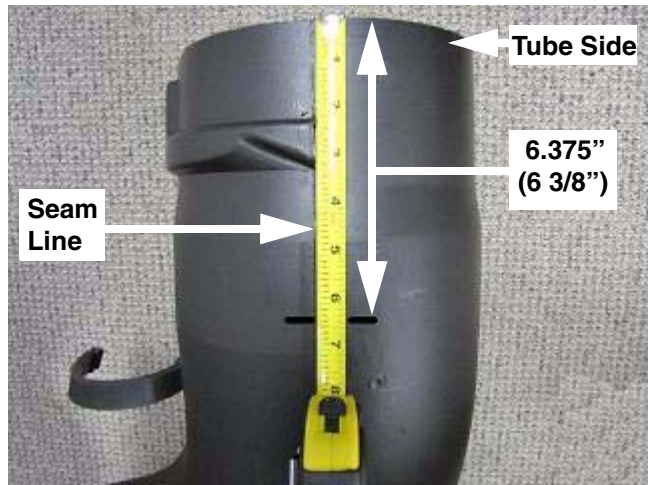

FIGURE 6

9. Measure 3/8" to the right of the seam line and make a mark. This will be the location to drill the 9/32" hole. See Figure 7.

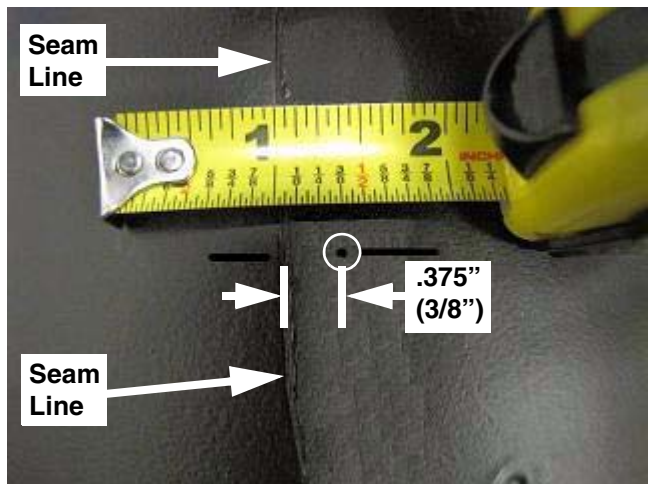

FIGURE 7

10. Drill a hole in the location marked in step 9, using a 9/32" drill bit. See Figure 8.



FIGURE 8

INSTALLATION INSTRUCTIONS:

11. Install Ref. #1 (710-0924) 1/4-20 x .75" machine screw through the bottom side hole and from the inside out of the upper bagger chute assembly as shown in Figure 9.

12. Place the short end of Ref. #5 (723-04009A) chute strap over the 1/4-20 x .75" machine screw on the outside of the upper bagger chute assembly and secure with Ref. #4 (712-3027) 1/4-20 flange lock nut. See Figure 9.

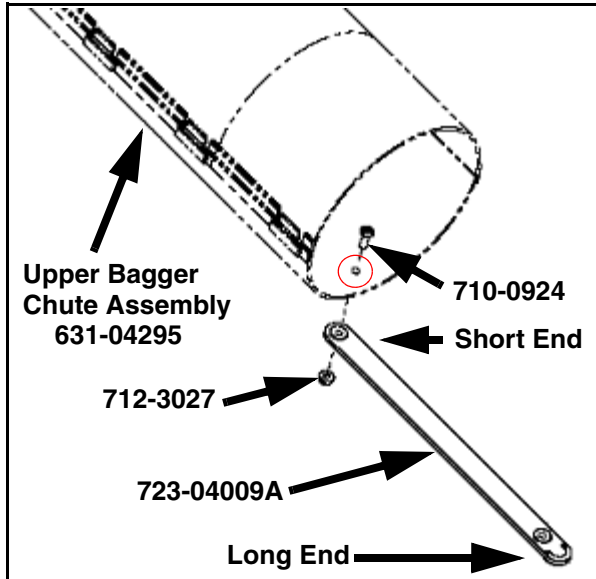

FIGURE 9

13. Install Ref. #2 (711-04069) grass catcher pin into the hole drilled in the discharge elbow chute assembly and secure with Ref. #3 (712-0324) 1/4-20 nylon lock hex nut. See Figure 10.



FIGURE 10

14. Assemble the bagger components as instructed in the Operators Manual for the 50"/54" Tripple Rear Bagger.

15. Secure the upper chute assembly to the discharge elbow chute assembly by hooking the long end of the chute strap installed in step 12 (Figure 9) to the grass catcher pin installed in step 13. See Figure 11.

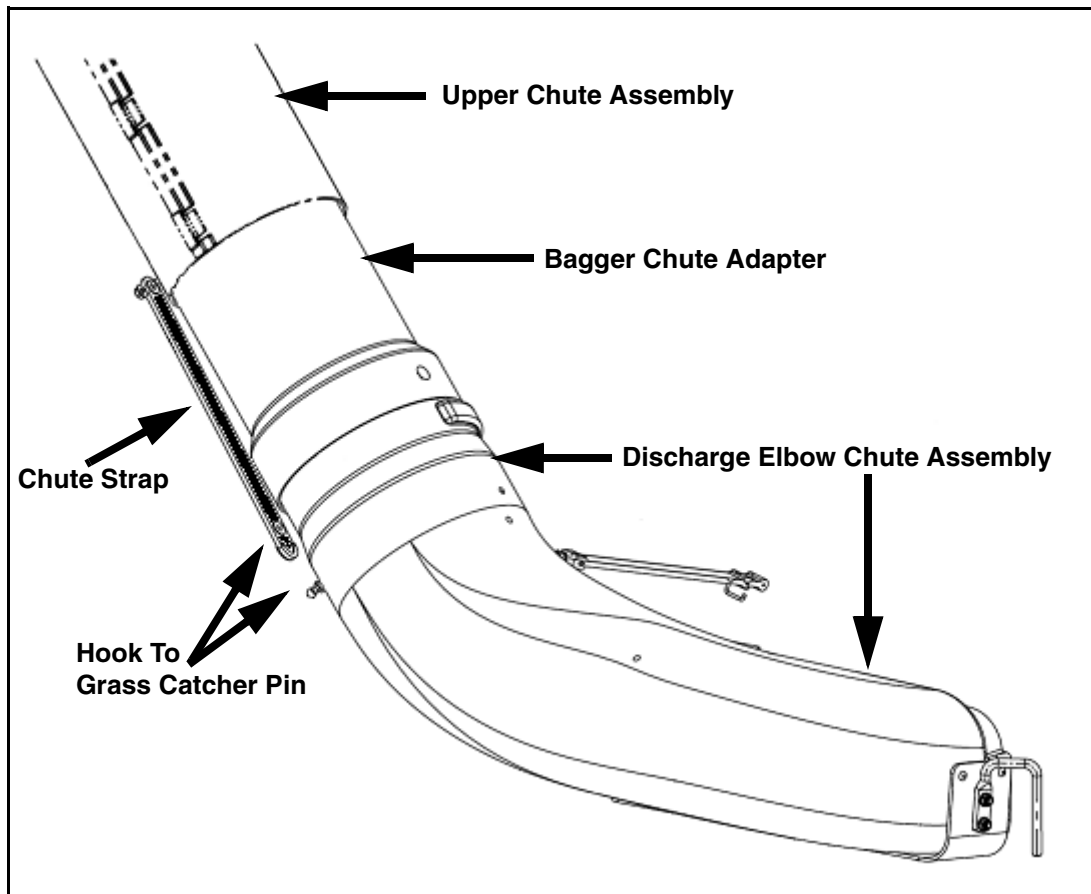

FIGURE 11