



# Service Kit 753-05953

Date: 9/17/2008

Subject: Service Replacement for 687-02134  
Rear Pivot Bracket Assembly

Models Affected: N/A

**Read through and understand these instructions completely before proceeding with repair.**

**PURPOSE:** This service kit provides the components and hardware necessary when replacing the 687-02134 Rear Pivot Bracket Assembly which is no longer available. This replacement pivot bracket requires a new transmission, transmission support bearings, bearing support spacers, handle brackets, trail shield and required hardware due to the extended length of the new Rear Pivot Bracket Assembly.

**NOTE:** *If the mower is to be used to cut in the lower 4 positions, this kit may be installed without the deck modification. If full height adjuster range is desired, it will require the deck modification. See "Deck Modification" section on page 8.*

**NOTE:** *These materials are prepared for use by trained technicians who are experienced in the service and repair of equipment of the kind described in this publication, and are not intended for use by untrained or inexperienced individuals. Such individuals should seek the assistance of an authorized service technician or dealer.*

**NOTE:** *Save this Instruction Sheet. Refer to it when ordering replacement parts.*

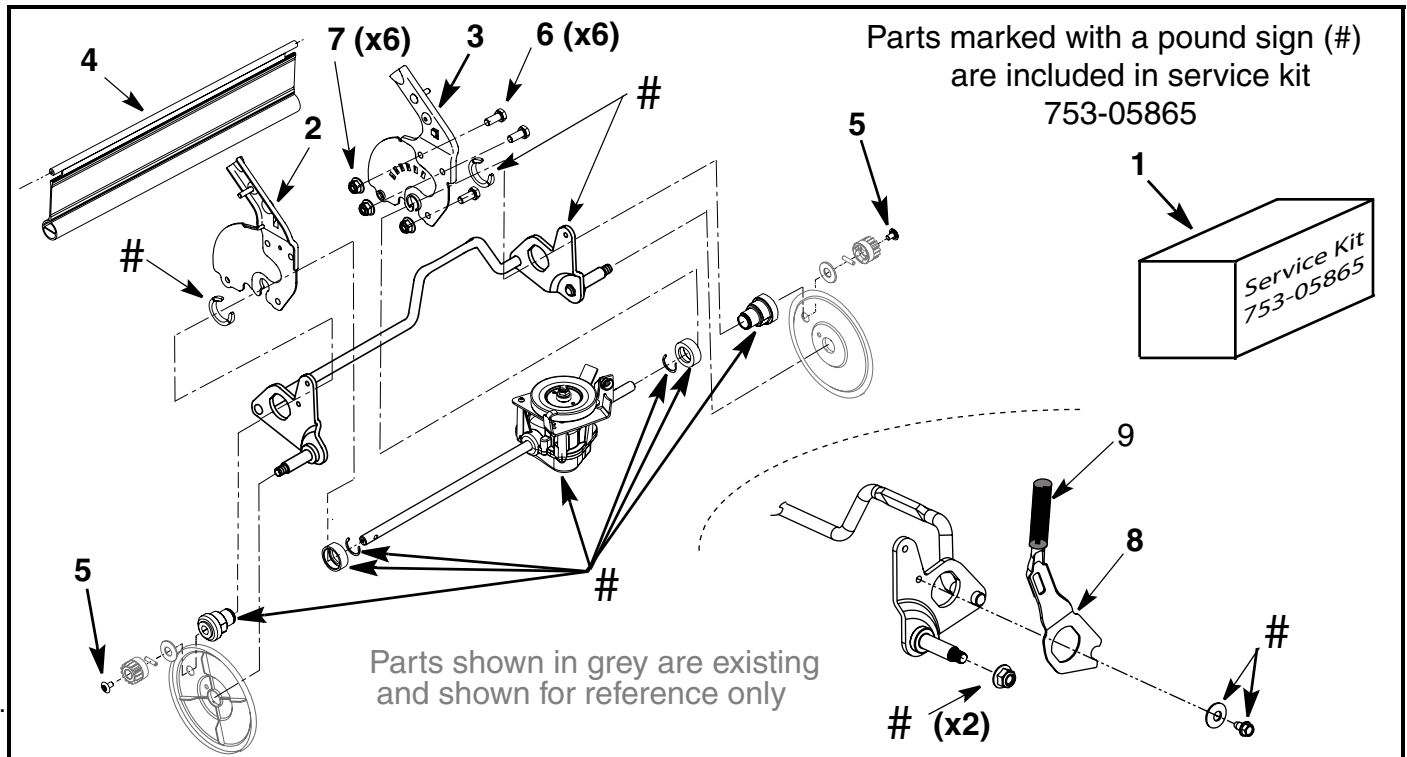

FIGURE 1

## Service Kit Contents (See Figure 1)

\* - Not Available Separately

ITEM NO.	PART NUMBER	QTY	DESCRIPTION
1	753-05865	1	KIT: SERVICE: REAR PIVOT BRKT
2	687-02321-0637	1	BRACKET ASSEMBLY: HANDLE: RH
3	687-02320-0637	1	BRACKET ASSEMBLY: HANDLE: LH
4	731-05462A	1	SHIELD: TRAIL
5	710-04531	2	SCREW: LOCKING: 1/4"-20 x .39 (PATCH)
6	710-3025	6	BOLT: 5/16"-18 x .625: GR5: STD.
7	712-04063	6	NUT: FLANGE LOCK: 5/16"-18: GRF: NYLON
8	732-04338A	1	LEVER: SPRING
9	720-0230	1	GRIP: FOAM
10	*	1	THIS INSTRUCTION SHEET

**Pre-Service Preparation:**

1. Place the mower on a flat and level surface.
2. Turn off the engine and allow the engine and muffler to cool before proceeding.
3. Remove the spark plug wire from the spark plug and ground the wire to the engine block.
4. Drain the fuel tank. Optional: Remove the fuel tank cap and place a thin sheet of plastic over the open fuel fill port. Replace the fuel tank cap tightly. Ensure the oil fill port cap/dipstick is tight.
5. Set the height adjuster to the highest cutting position.

**Drive System Disassembly:**

**NOTE:** Left (LH) and right (RH) are determined from the operator's position at the rear of the mower facing forward.

**NOTE:** Refer to the Operator's Manual - Illustrated Parts List for part nomenclature and location.

**NOTE:** Retain all parts and hardware unless instructed otherwise.

6. If so equipped, remove the cross bracket's (front-to-rear height adjuster bar) plastic cover by releasing the two lock tabs. See Figure 2.

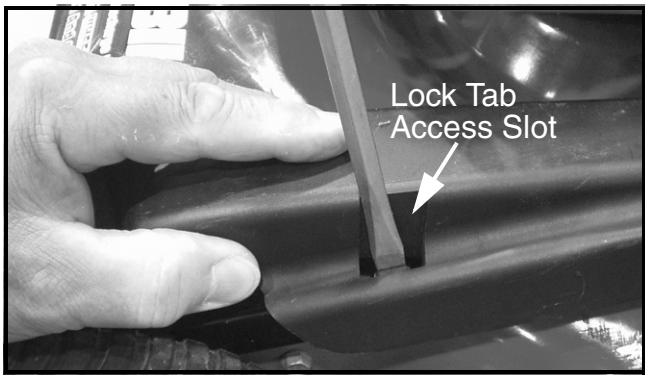

**FIGURE 2**

7. Using a spring puller P/N 732-0571, or other suitable tool, carefully unhook the height adjust extension spring from the cross bracket. See Figure 3.

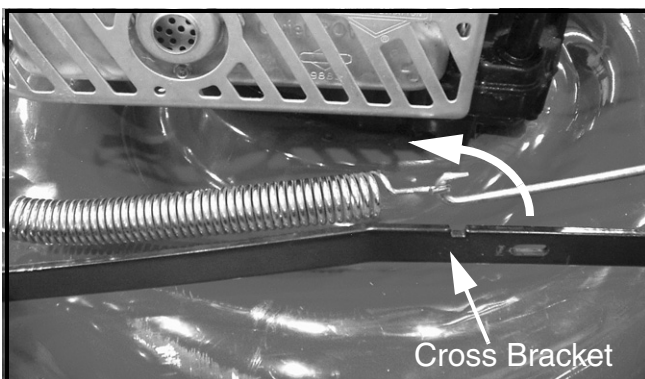
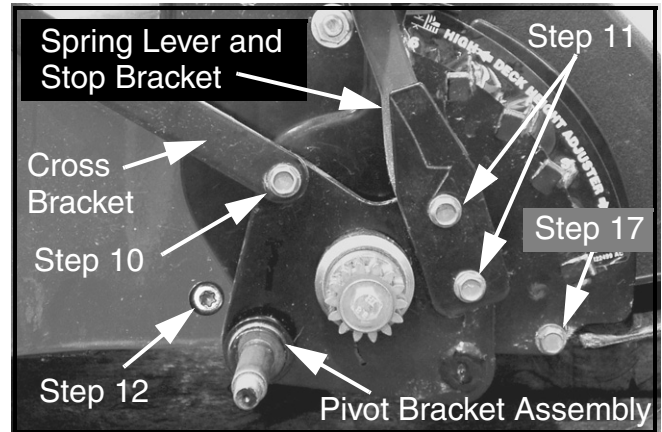

**FIGURE 3**

8. Place wood blocking (about 5-6" high) under the rear edge of the mower deck to raise the rear wheels off of the ground.

9. Using a 9/16" socket and ratchet, remove and discard the hex flange lock nuts retaining the wheels to the pivot bracket assembly's axle studs. Remove both wheels.

10. Using a 3/8" socket and ratchet, remove the self-tapping screw, spacer and wave washer (if so equipped) securing the cross bracket to the pivot bracket assembly. See Figure 4.

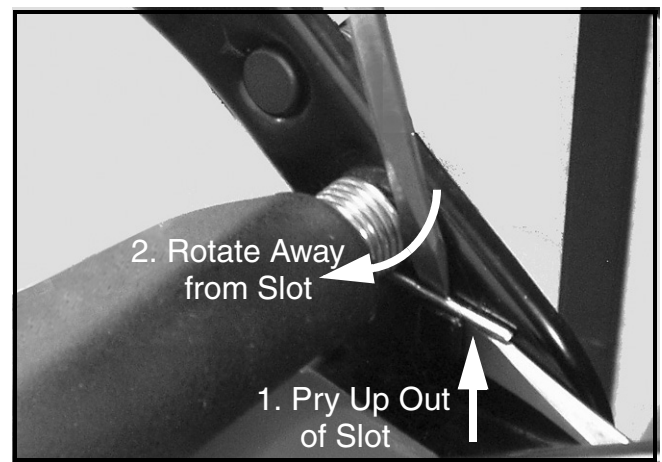

**FIGURE 4**

11. Using a 3/8" socket and ratchet, remove the two self-tapping screws securing the height adjuster spring lever and stop bracket. See Figure 4.

12. Using a T-30 Torx bit and ratchet, remove the two Hi-Lo screws securing the main baffle to the deck. See Figure 4.

13. Refer to Figure 5. Using two thin flat blade screw drivers, unhook the rear door's left side torsion spring leg from the handle bracket. Do the same for the right side torsion spring.



**FIGURE 5**

14. Using a pair of long nose pliers, gently compress the two locking tabs on the ERS cable's housing end and push back to slide the cable's end out of the engine's mounting bracket. See Figure 6.

15. Unhook the ERS cable's "Z" fitting from the engine's brake lever and remove the cable from engine.

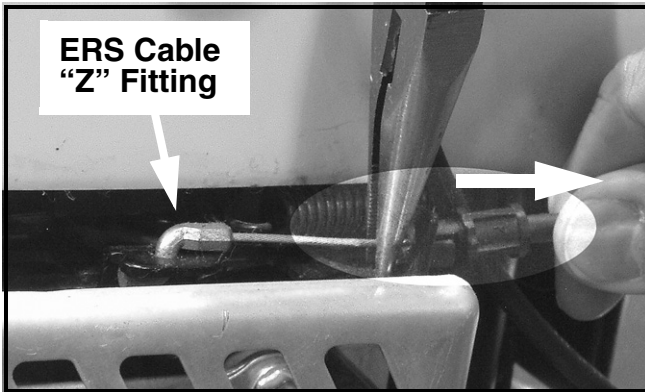

FIGURE 6

16. Remove the two plastic handle knobs securing the handle assembly to the handle brackets. Remove the handle assembly from the handle brackets and set down next to the mower with drive cable still attached.

17. Using a 3/8" socket and ratchet, remove and discard the two special screws that secure the trail shield to the handle brackets. Discard the trail shield. See Figure 4.

18. Using a 3/8" socket and ratchet, remove the two screws that secure the rear door pivot rod to the handle brackets.

19. Using a 1/2" socket and ratchet, just loosen by one or two turns the two upper hex nuts securing one of the handle brackets to the deck.

20. Remove the rear door, rear door pivot rod and both torsion springs from between the LH and RH handle brackets and set aside.

21. Place the mower on it's side so that the air filter/carburetor are up towards the sky. Check for oil or fuel leaks, correct if necessary. Secure mower with blocking as shown in Figure 7.

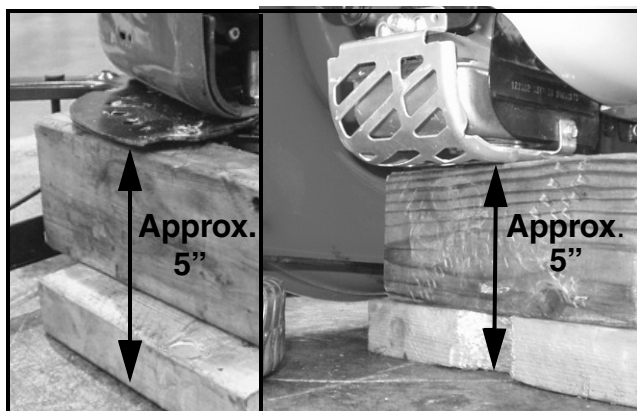

FIGURE 7

**WARNING: When removing the cutting blade use a blade removal tool or protect your hands with a pair of heavy gloves or use a heavy rag to hold blade.**

22. Using a 3/4" socket and breaker bar, remove the bolt and blade bell support securing the blade to the crankshaft.

23. Remove the blade adapter, wave washer(s), flat washer(s) and spacer (if so equipped).

**NOTE: IMPORTANT - Note the sequence and orientation of the wave washer(s), flat washer(s) and spacer (if so equipped) so that they will be re-installed in the correct order later.**

24. If so equipped, remove the two screws securing the donut baffle to the deck. Then lift the donut baffle up and slide forward away from the main baffle to unhook the two donut baffle locking clips from the main baffle. See Figure 8. Mounting hardware varies dependent on model and year.

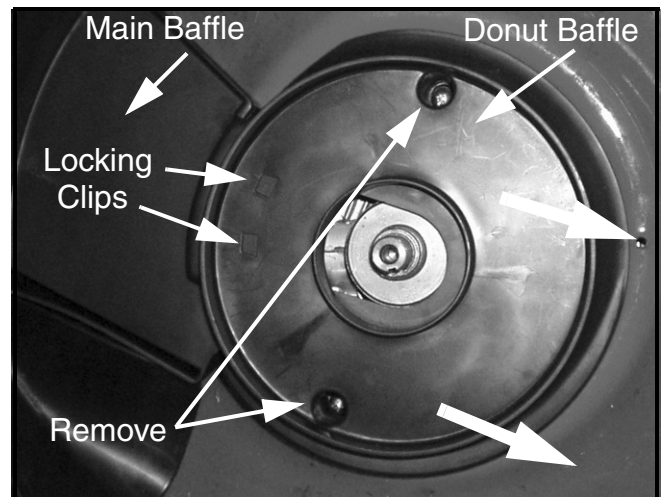

FIGURE 8

25. Using a 3/8" socket with extension (or a deep socket) and ratchet, remove the self-tapping screw retaining the front portion of the main baffle. See Figure 9.

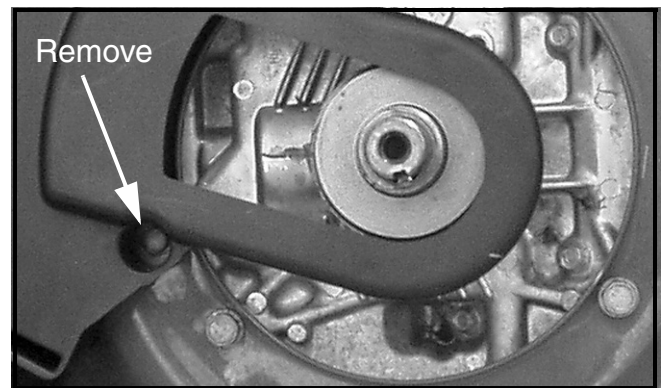

FIGURE 9

26. Carefully lift the front portion of the main baffle sufficiently to remove the lower half of the engine pulley. See Figure 10.

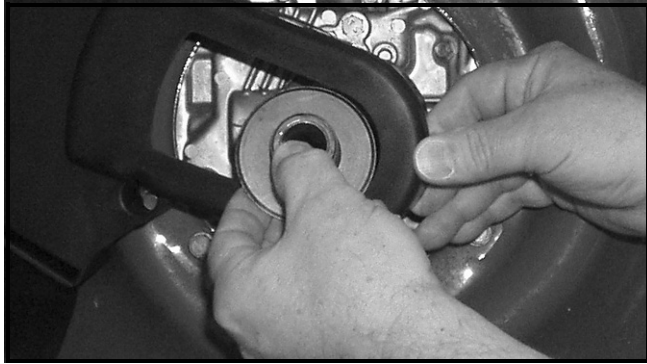

FIGURE 10

27. Slip the belt off of the crankshaft. Remove the upper pulley half and spacer (if so equipped).

28. Using a pair of vise grip pliers, securely clamp onto the transmission's output shaft as shown in Figure 11.



FIGURE 11

29. Using a 10mm socket (or 3/8" socket or T30 Torx bit however equipped) and ratchet **and holding the vise grip pliers to keep the transmission output shaft from rotating**, remove the screw retaining the LH spur gear to the transmission's output shaft and spur gear. Do the same for the RH spur gear. See Figure 12.

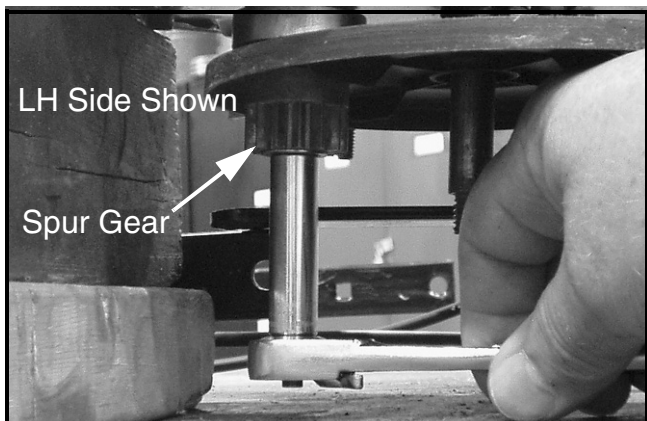

FIGURE 12

30. Remove the vise grip pliers from the transmission's output shaft.

31. Remove the LH (bottom) dowel pin, flat washer and wheel dust cover.

**NOTE: The spur gears are right and left side specific. Mark or tag each spur gear as to the side it was removed from.**

32. On the LH side, slide the transmission support bearing off of the transmission's output shaft and discard. Remove and discard the plastic spacer clip. See Figure 13.

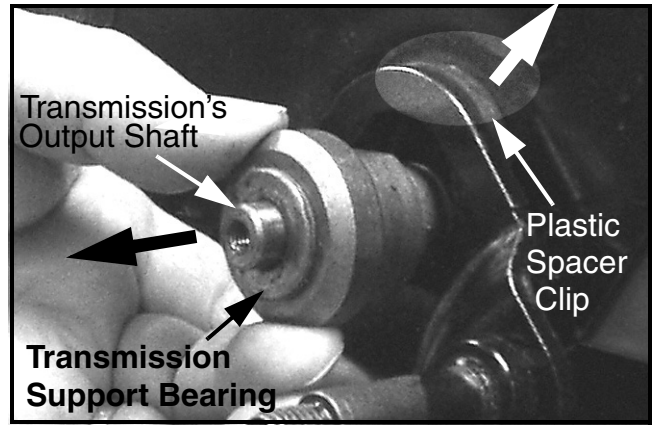

FIGURE 13

33. While holding the transmission from dropping, remove the RH (top) dowel pin, flat washer and wheel dust cover.

34. On the right (RH) side, remove and discard the transmission support bearing from the transmission's output shaft and plastic spacer clip.

35. Pull the transmission out partially from the deck and slide each end of the pivot bracket assembly off of each end of the transmissions' output shaft. Discard the pivot bracket assembly. See Figure 14.

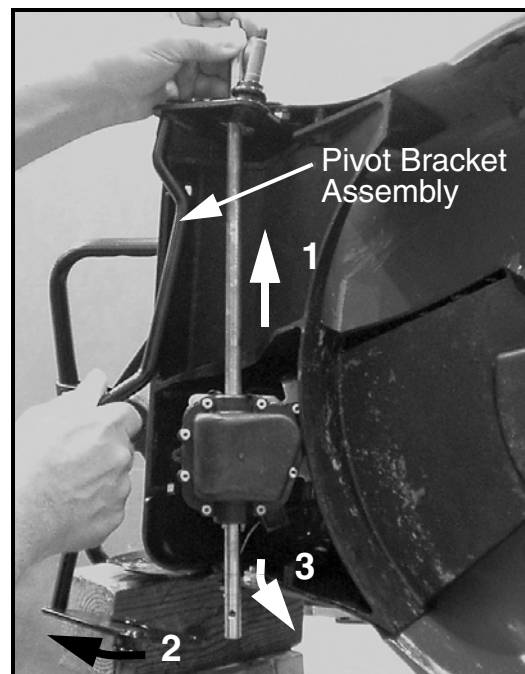
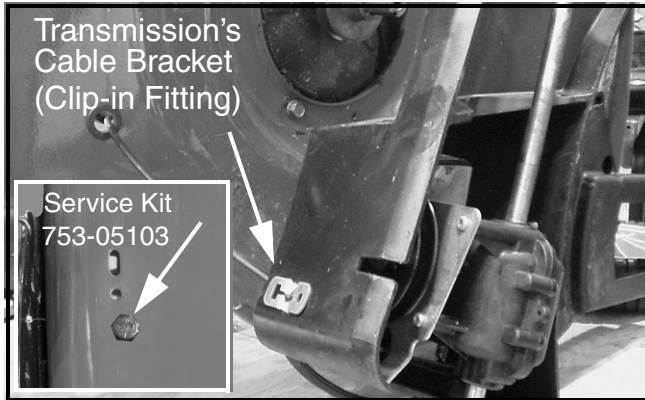

FIGURE 14

**NOTE:** Service kit 753-05103 installed a hex head bolt and nut securing the transmission cable bracket and main baffle to the rear of the deck. See Figure 15 Inset below. If the service kit had previously been installed, remove the bolt and nut using a 7/16" socket and ratchet and a 7/16" box wrench.

36. Carefully pull the transmission and main baffle out from the deck and position it so that there is access to the transmission cable bracket (clip-in fitting). See Figure 15.



**FIGURE 15**

37. Using a large flat blade screw driver, remove the transmission cable bracket (clip-in fitting) from the main baffle. See Figure 16.

38. Unhook the transmission cable from the transmission cable bracket (clip-in fitting).

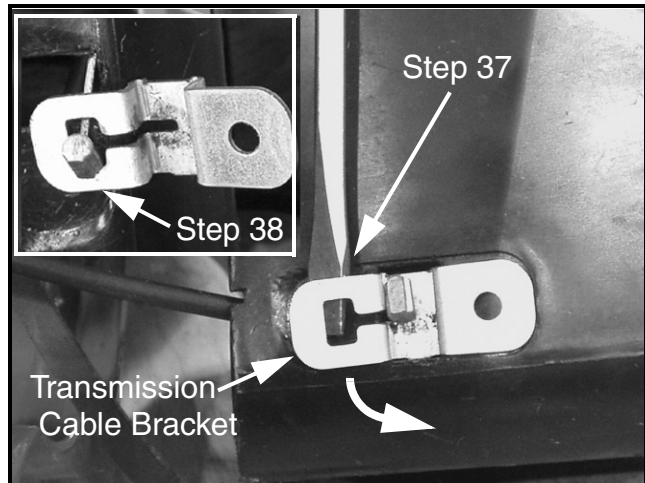

**FIGURE 16**

39. With two thin flat blade screw drivers, carefully compress the two locking tabs on the transmission cable's end fitting and slide the fitting back out of the transmission cable's mount on the transmission bracket. See Figure 17.

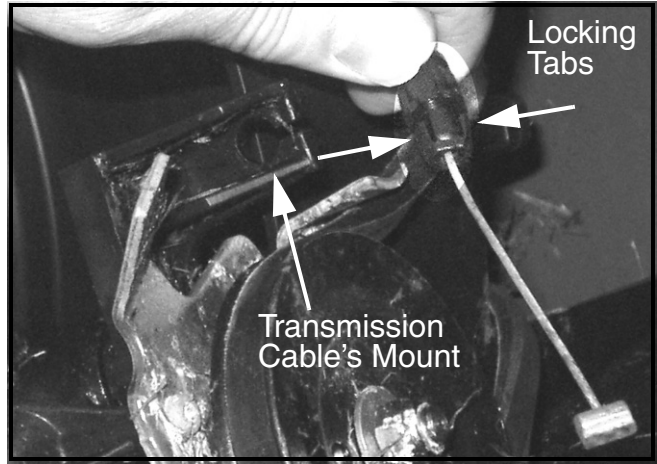

**FIGURE 17**

40. Remove the transmission, belt and main baffle from the deck. Remove the belt from the transmission. Discard the transmission.

**NOTE:** Check the condition of the belt. Replace if worn or damaged. This is an opportune time to replace the belt even if it is still usable.

41. Reposition the wood blocking from under the LH handle bracket forward onto the deck shell. See Figure 18



**FIGURE 18**

42. Using a 1/2" socket and ratchet remove the carriage bolts and lock nuts securing both the RH and LH handle brackets. Discard the handle brackets and mounting hardware.

**NOTE:** If it is required to modify the deck, see "PURPOSE" on page 1, proceed to "Deck Modification" on page 8 before proceeding to "Drive System Reassembly".

#### Drive System Reassembly:

43. Using a 1/2" socket and ratchet and a 1/2" box wrench, install the new LH Handle Bracket, Item 3, using three 5/16"-18 x .62 Bolts, Item 6, and three 5/16"-18 Flange Lock Nuts, Item 7. Tighten all hardware.

44. Reposition the wood blocking from under the deck shell back under the LH handle bracket.

45. Place the new RH Handle Bracket, Item 2 in place and hand start three 5/16"-18 x .62 Bolts, Item 6, and three 5/16"-18 Flange Lock Nuts, Item 7.

46. Insert one end of the new Trail Shield, Item 4, into the hole in the LH Handle Bracket. Insert the other end of the trail shield into the RH handle bracket. Tighten the RH handle bracket hardware.

47. Feed the drive cable through the rectangular hole in the main baffle. Reinstall the drive cable barrel end onto the transmission cable bracket (clip-in fitting) as shown in Figure 16.

48. Snap the clip-in fitting into the main baffle's rectangular hole. Refer to Figure 16.

49. Insert the main baffle into the deck shell. If so equipped, reinstall the 1/4"-20 bolt and nut securing the transmission's cable bracket (clip-in fitting) and main baffle to the rear of the deck. Refer to Figure 15.

50. Re-install the two Hi-Lo screws, removed in Step 12, to secure the main baffle to the deck at the handle brackets. See Figure 4.

51. Open Service Kit 753-05865 supplied in service kit 753-05953. You will not need the instruction sheet 769-03932A except for the illustrated parts list on page 1.

52. Install the belt onto the new Transmission, Item 1 of 753-05865, pulley. Ensure the belt is inside of the transmission's belt guides. Place a small rubber band around the belt to hold the belt onto the pulley and within the guides. See Figure 19.

53. Slide a Bearing Support Spacer, Item 7 of 753-05865, onto each end of the transmission's output shafts. The smaller diameter bore of the spacer must be next to the transmission body. See Figure 19.

**NOTE:** Use a rubber band or masking tape to hold the spacers to the transmission body during the next assembly steps.

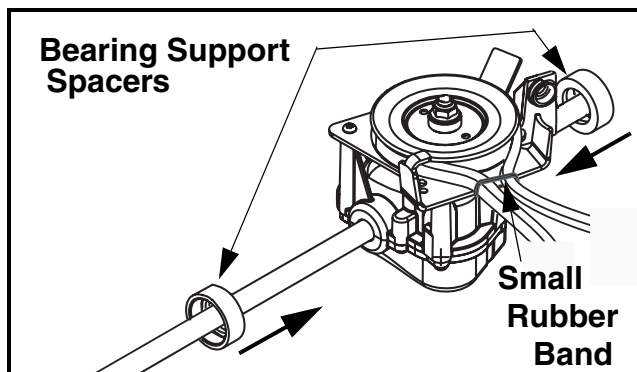

FIGURE 19

54. Hook one end of the transmission return spring onto the tab on the main baffle as shown in Figure 20. Temporarily hook the other end to the slot in the main baffle. See Figure 20 inset.

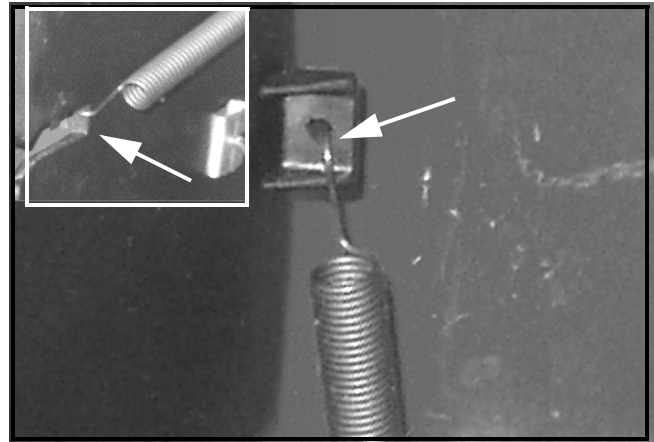

FIGURE 20

55. Insert the locking tabs end of the drive cable into the drive cable socket on the transmission's cable mount. Refer to Figure 17.

56. Route the loose looped end of the belt up through the main baffle's passageway to the crankshaft.

57. Install the new Pivot Bracket Assembly, Item 2 of 753-05865, onto the transmission. Refer to Step 35 and Figure 14. Ensure that the offset in the pivot bracket rod is positioned at the transmission's body.

58. Insert the transmission/pivot bracket/belt/support spacers subassembly into position within the RH and LH handle bracket keyhole slots. Ensure that both pivot bracket assembly's pivot arms are on the outside of the deck.

59. Using a light weight lithium or silicone grease, lubricate the RH end of the transmission output shaft where the transmission support bearing will set and a dowel pin.

60. Install a new Transmission Support Bearing, Item 8 of 753-05865, onto the RH end of the transmission's output shaft. Install the flat washer, removed in Step 33 and install the lubricated dowel pin in the output shaft. See Figure 21.

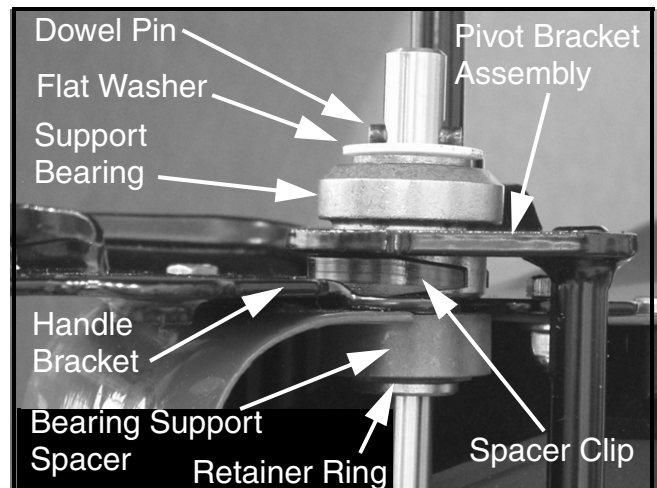

FIGURE 21

61. Insert a new Spacer Clip, Item 5 of 753-05865, between the pivot bracket assembly and the handle bracket. See Figure 21.

62. Position the RH Bearing Support Spacer, Item 8 of 753-05865, up against the inside of the deck and fully insert a Retainer Ring, Item 4 of 753-05865, into the groove on the transmission support bearing. See Figure 21.

63. Lift up and hold the transmission so that the RH dowel pin is accessible. Remove the dowel pin and flat washer.

64. Install the wheel cover removed in Step 33, replace the flat washer and dowel pin.

65. Install the RH spur gear onto the RH end of the transmission's output shaft. The RH spur gear has an "R" embossed on one of the ramp surface sides.

66. Using a T30 Torx bit and small ratchet, just start a new 1/4"-20 Torx Head Patch Screw, Item 5, do not tighten.

67. Using a pair of long nose pliers unhook the transmission extension spring from the deck slot and hook it into the spring mount hole on the transmission body. See Figure 22.



FIGURE 22

68. Using a light weight lithium or silicone grease, lubricate the LH end of the transmission output shaft where the transmission support bearing will set and a dowel pin.

69. Install a new Transmission Support Bearing, Item 8 of 753-05865, onto the LH end of the transmission's output shaft. Install the flat washer, removed in Step 33 and install the lubricated dowel pin in the output shaft. Refer to Figure 21.

70. Position the LH Bearing Support Spacer, Item 8 of 753-05865, up against the inside of the deck and fully insert a Retainer Ring, Item 4 of 753-05865, into the groove on the transmission support bearing. See Figure 21.

71. Re-install the belt onto the crankshaft.

72. Re-install the lower pulley half onto the crankshaft. Ensure the belt is not trapped against the crankshaft. Refer to Step 26 and Figure 10.

73. Reinstall the screw securing the front portion of the main baffle to the deck using the screw removed in Step 25. See Figure 9.

74. Re-install the donut baffle using the hardware removed in Step 24. See Figure 8.

75. Lubricate the crankshaft and inner surface of the blade adapter with a light oil.

76. Re-install, on the crankshaft, the spacer (if so equipped), flat washer(s), wave washer(s), and blade adapter. Refer to Step 23.

77. Re-install the blade, blade bell support and blade retainer bolt. **Torque the blade retainer bolt to 450-600 In-Lbs.**

78. Apply the vise grip pliers to the new transmission's output shaft as in Step 28, Figure 11.

79. Return the mower to its' normal position with the rear of the deck setting on the wood blocks.

80. Insert a new Spacer Clip, Item 5 of 753-05865, on the LH side between the pivot bracket assembly and the handle bracket. See Figure 21.

81. Using a 3/8" socket and ratchet, secure the new Bell Washer, Item 6 of 753-05865, (cupped side towards height adjuster lever) with the TapTite Screw, Item 3 of 753-05865, to the left pivot bracket assembly pivot arm as shown in Figure 21. Tighten securely.

**NOTE:** *The bell washer will overlap the edge of the height adjuster lever providing required adjuster spring force.*

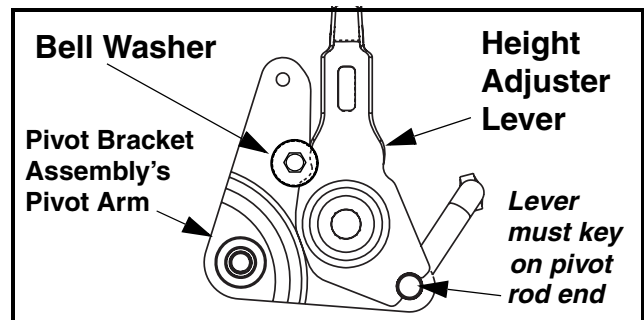

FIGURE 23

82. On the LH side, re-install the cross bracket using the wave washer (if so equipped), spacer and tap-tite screw removed in Step 17. Refer to Figure 4.

83. Re-install the LH wheel cover.

84. Using a light lithium or silicone base grease, lubricate the dowel pin and install it in the cross hole of the LH transmission output shaft.

85. Install the LH spur gear onto the end of the LH output shaft. The LH spur gear has an "L" embossed on one of the ramp surface sides.

86. Using a T30 Torx bit and small ratchet, install a new 1/4"-20 Torx Head Patch Screw, Item 5. Tighten both LH and RH Torx Head Patch Screws.

87. Install the flat washer onto the LH pivot bracket assembly arm axle stud.

88. Install the both rear wheels using a new 3/8"-16 Flange Lock Nut, Item 9 of 753-05865.

89. Hook one end of the height adjust extension spring into the hole on the forward LH side of the deck. Using a spring puller P/N 732-0571, or other suitable tool, carefully hook the other end of the height adjust extension spring onto the cross bracket. See Figure 3.

90. If so equipped, Re-install the cross bracket's plastic cover onto the cross bracket. Ensure the two lock tabs securely snap over the cross bracket. See Figure 2.

91. Remove the wood blocks, reconnect the spark plug wire to the spark plug and remove the plastic sheet from under the fuel cap (if applicable).

92. Start the mower and engage the self-propelled drive...that will break the rubber band from around the belt.

This completes this service kit's installation.

### Deck Modification:

Perform the **Drive System Disassembly** procedure before performing the **Deck Modification**.

The deck modification procedure was accomplished with a small handheld high-speed rotary tool, similar to a Dremel, with an abrasive cutoff disc and drum sander accessories.

D1. Raise and block the rear portion of the deck as shown in Figure A.

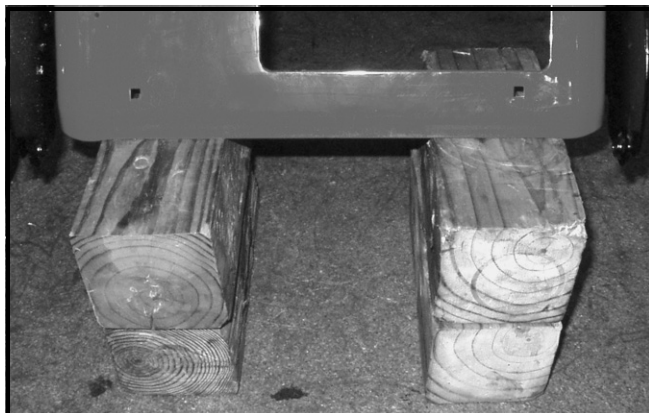

FIGURE A

D2. Temporarily install both new Handle Brackets, Items 2 and 3, using just the new 5/16"-18 x .625 Bolts, Item 6, to position the brackets.

D3. With a permanent marker, trace the outline of the pivot bracket relief for the LH and RH Handle Brackets onto the deck shell as shown in Figure B (RH shown).

D4. To simplify the cut out, extend a line (dotted line) from the top of the outline to the "U" cutout edge of the deck. See Figure B.

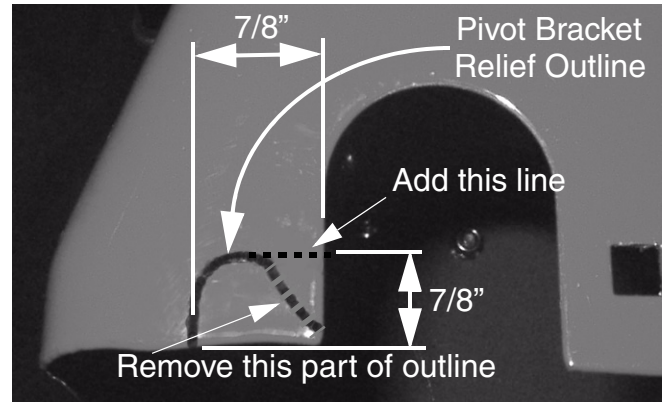

FIGURE B

**CAUTION: Wear eye protection, i.e. safety glasses, when using any type of power tool as in the next steps.**

D5. With a thin abrasive cut-off disc installed on a handheld rotary tool, grind along the marked outline. To speed removal of the material you need only to remove about half the depth of the deck material thickness along the outline. Do both RH and LH sides. See Figure C-1

D6. Using a pair of pliers, work the tabs back and forth to break them away from the deck. See Figure C-2.

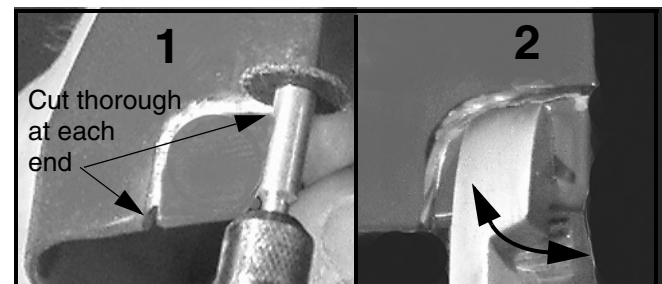

FIGURE C

D7. Change the cutoff tool to the drum sander with a 60 grit sleeve installed. Smooth all sharp edges and round off the corners. See Figure D.

D8. Apply two coats of a primer sealer paint to the bare metal surfaces.

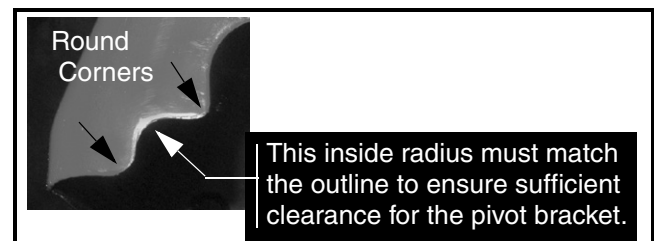

FIGURE D

This completes the deck modification.