



Service Kit 753-05471

Date: 3/29/2007

Subject: Rear Attachment Support Brackets for the 700 Series Lawn Tractor.

Models Affected: OEM-190-180 (38" and 42" decks) and OEM-190-182 (46" decks) Grass Bagger Attachments built prior to May, 1, 2007 (Date Code "...E017...")

REF: S/A MTD-063

Read through and understand these instructions completely before proceeding with repair.

PURPOSE: This service kit provides weight distribution support brackets for Rear Bagger Attachments (See "Models Affected" above) on 700 Series Lawn Tractors.

NOTE: These materials are prepared for use by trained technicians who are experienced in the service and repair of equipment of the kind described in this publication, and are not intended for use by untrained or inexperienced individuals. Such individuals should seek the assistance of an authorized service technician or dealer.

NOTE: Save this Instruction Sheet. Refer to it when ordering replacement parts.

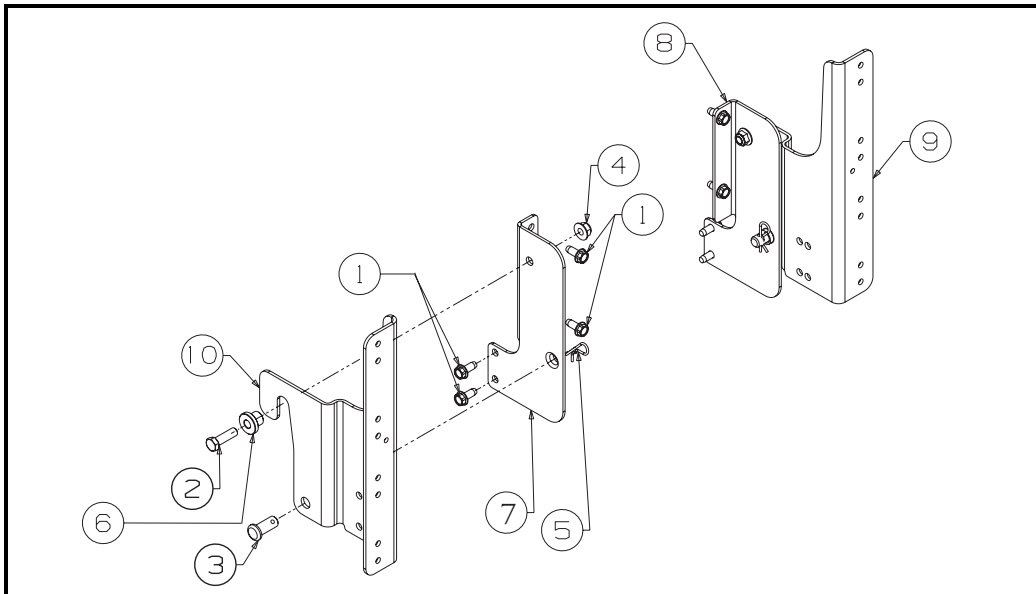

FIGURE 1

Service Kit Contents (See Figure 1)

ITEM NO.	PART NUMBER	QTY	DESCRIPTION
1	710-1260A	8	SCREW:TT: 5/16"-18 x .750":HXINDWSH
2	710-3005	2	SCREW:HHCS:3/8"-16 x 1.25":GR5:STD
3	711-0310	2	PIN:CLEVIS: .50" DIA. x 1.18" LG
4	712-04065	2	NUT:FLANGELOCK:3/8"-16:GRF:NYLON
5	714-0145	2	PIN:COTTER:INTERNAL: .092" x 1.64" LG
6	738-04058	2	SPACER:SHOULDER: .38" x 1.0" x .70"
7	783-04919	1	BRACKET:MOUNTING: LH/RR
8	783-04968	1	BRACKET:MOUNTING:RH/RR
9	783-0673B	1	BRACKET:CATCHER:SUPPORT:RH
10	783-0764B	1	BRACKET:CATCHER:SUPPORT:LH
11	*	1	THIS INSTRUCTION SHEET

* - Not Available Separately

NOTE: References to LEFT (LH) and RIGHT (RH) indicate the left and right sides of the tractor when facing forward in the operator's position.

Pre-Service Preparation:

1. Place tractor on a flat and level surface, turn OFF engine, remove ignition key and set the parking brake ON.

2. The 2-hole bagger attach support brackets (see Figure 2) that may have come with the Twin Grass Bagger Attachment package may be used to install the grass bagger on the 700 Series lawn tractors. Use this service kit in lieu of the 2-hole brackets and for Twin Grass Bagger Attachments that did not come with the 2-hole brackets.

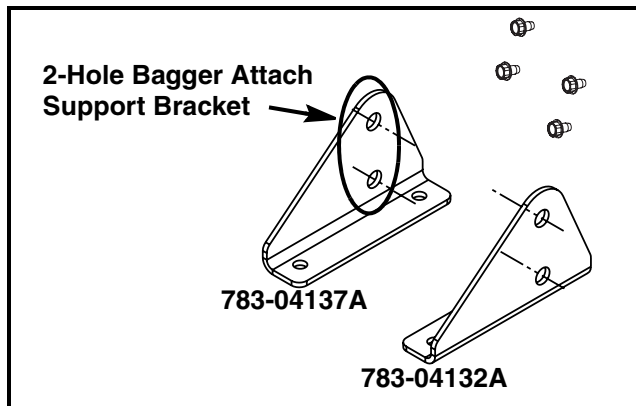

FIGURE 2

Existing Bagger Bracket Assembly Knock Down:

3. Refer to Figure 3. Remove parts "A1", "A2" and "A3" as a sub-assembly "A". Using a 7/16" socket and ratchet and 7/16" box wrench remove the eight (8) 1/4"-20 screws and hex lock nuts indicated in Figure 3, from the catcher support brackets "B1" and "B2". Set the "A" sub-assembly aside.

4. Using a 1/2" socket and ratchet and 1/2" box wrench, remove the four (4) 5/16"-18 screws and 5/16" securing the cross support bracket "C1" to the two (2) the catcher support brackets "B1" and "B2".

Discard the two (2) catcher support brackets "B1" and "B2". Retain the cross support bracket "C1".

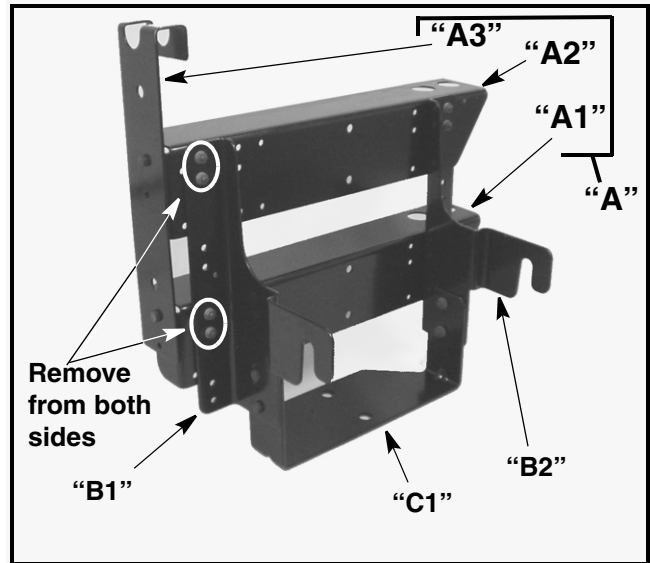

FIGURE 3

Installation Instructions:

5. Remove the contents of the service kit and familiarize yourself with the components using Figure 1 and the Kit Contents table.

6. At the rear of the tractor, if the brackets shown in Figure 2 are already installed on the tractor, remove and discard them and the 4 securing screws.

7. Starting on either the right or left side of the tractor, locate the appropriate side's Mounting Bracket (Item 7 or 8) and install the Mounting Bracket using four (4) Self-Tapping Screws, Item 1. Align and start all four screws before tightening. See Figure 4. Do the same for the other side.

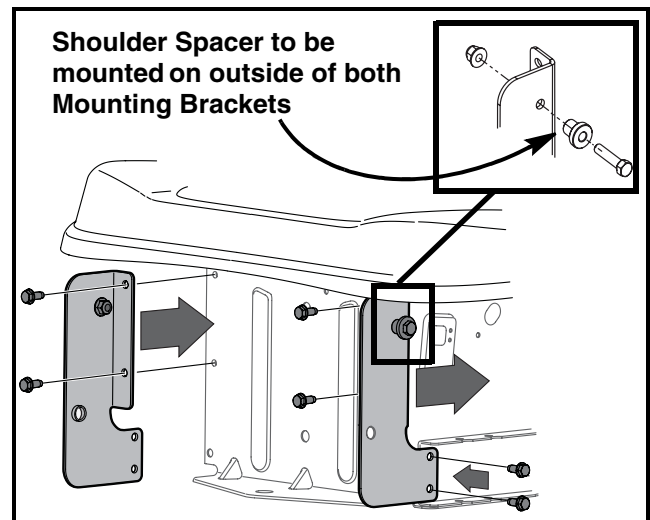

FIGURE 4

8. Refer to Figure 4 Inset. For both Mounting Brackets, Items 7 and 8, install the Shoulder Spacer, Item 6, using a 3/8"-16 x 1.25" Hex Head Screw, Item 2, and a 3/8" Hex FlangeLock Nut, Item 4. Tighten securely.

9. Using the two new Catcher Support Brackets, Items 9 and 10, supplied in this kit, and the four 5/16"-18 screws and lock nuts from Step 4, mount the cross support bracket "C1" (from Step 4) as shown in Figure 5. Note the orientation of the cross support bracket's extended lip "A". Do not tighten the screws at this time, allow brackets to move slightly.

The cross support bracket mounts in the two forward holes in the Catcher Support Brackets.

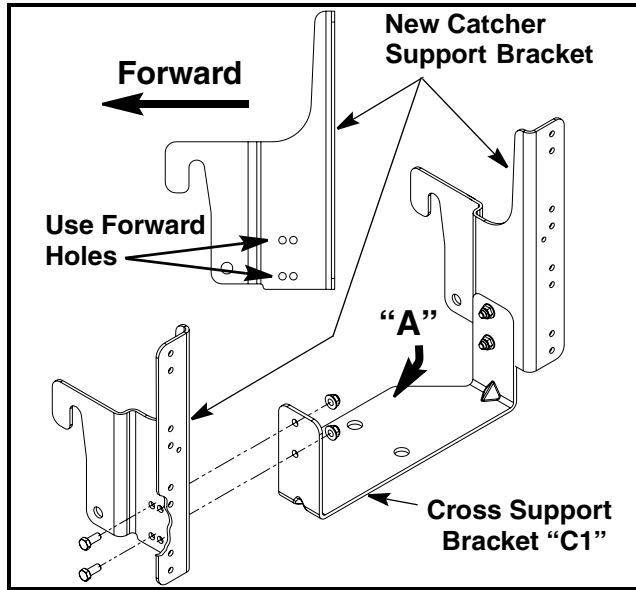

FIGURE 5

10. Using a 7/16" socket and ratchet and 7/16" box wrench, install the "A" sub-assembly with the eight (8) 1/4"-20 x .62" screws and 1/4" -20 hex lock nuts removed in Step 3. Do not tighten at this time, allow brackets to move slightly.

11. Set the upgraded catcher support assembly onto the tractor's Mounting Brackets as shown in Figure 6. Ensure that the catcher support assembly hooks equally onto the Fast Attach Shoulder Spacers and sets on top of the tractor's hitch plate.

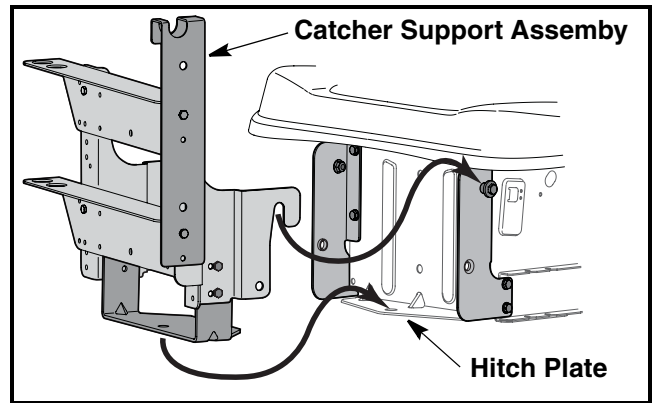

FIGURE 6

12. Install the two (2) Clevis Pins, Item 3, as shown in Figure 7 and secure with Internal Cotter Pins, Item 5, supplied in this kit, securing the catcher support assembly to the new FastAttach Mounting Brackets.

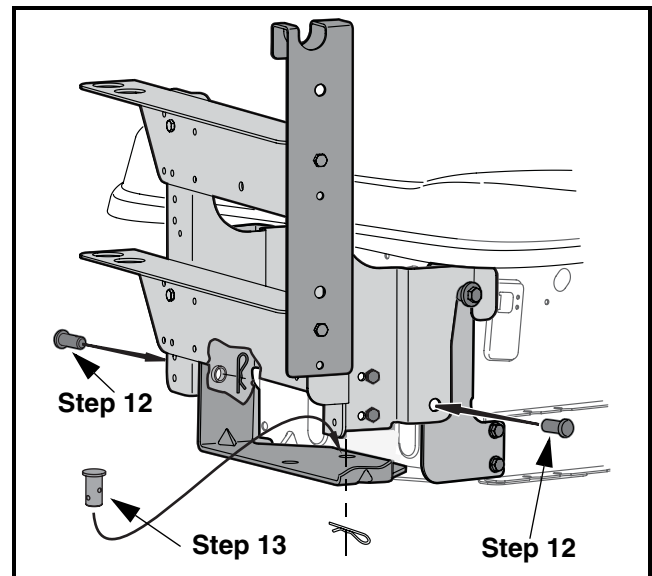

FIGURE 7

13. Locate the 5/8" diameter clevis pin and .148" diameter internal cotter pin from the Twin Grass Bagger Attachment package and install it as shown in Figure 7.

14. Tighten all hardware (12 screws and lock nuts) on the catcher support bracket assembly.

15. This completes the installation of this service kit.

16. Complete the assembly and installation of the Twin Grass Bagger Attachment in accordance with the attachment's Operator's Manual.