



Service Advisory

ZT SERIES

W-148

Models Affected: ZT 17 (17AA5A4G790), ZT 42 (17BA5A4G790)

Serial Number Range Affected: 2004 through 2006

Date: December 12, 2006

Subject: Service Replacement Hydro Transmissions 759-04142 & 759-04143

IMPORTANT ATTENTION PARTS MANAGER ATTENTION SERVICE MANAGER

These Service Kits will replace the LH & RH hydro transmissions part numbers 618-04164, 618-04164A, 618-04327 & 618-04163, 618-04163A, 618-04326 when stock is depleted. The replacement transmission has a Double-D axle which requires a Double-D wheel hub assembly. The LH Transmission Service Kit 759-04142 & the RH Transmission Service Kit 759-04143 will include the items shown below.

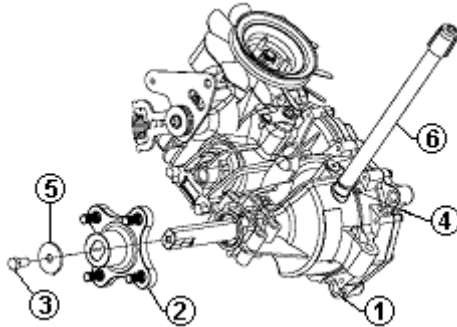

759-04142 Service Kit Contents

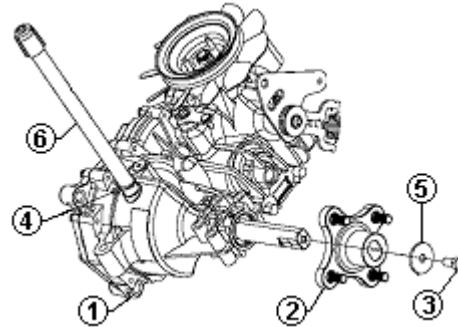

759-04143 Service Kit Contents

ITEM NO.	PART NUMBER	QTY	DESCRIPTION
1	618-04494	1	HUB ASM: WHL:DOUBLE-D SHORT
2	618-04431A	1	TRANS ASM: HYDRO:EZT:LH
3	710-3119	1	SCREW:3/8"-16 x .750:GR5:LOCK
4	726-04059	1	CLAMP:HOSE: .750
5	736-0227	1	WASHER:FLAT: .390 x 1.50 x .134
6	751-10474	1	HOSE:BREATHER

Instruction Sheet included with kit.

ITEM NO.	PART NUMBER	QTY	DESCRIPTION
1	618-04494	1	HUB ASM: WHL:DOUBLE-D SHORT
2	618-04432A	1	TRANS ASM: HYDRO:EZT:RH
3	710-3119	1	SCREW:3/8"-16 x .750:GR5:LOCK
4	726-04059	1	CLAMP:HOSE: .750
5	736-0227	1	WASHER:FLAT: .390 x 1.50 x .134
6	751-10474	1	HOSE:BREATHER

Instruction Sheet included with kit.

Please make a note of this information in your business system and parts manuals.

This is being released for informational purposes only.

SERVICE MANAGER	PARTS MANAGER	SALES MANAGER	SERVICE TECH.	SERVICE TECH.

Circulate and Initial



Service Kit

759-04142

Date: 11/21/2006

Subject: Service Replacement for the 42" RZT Left Hand (LH) Hydro Transmission

Models Affected: N/A

PURPOSE: This service kit replaces the LH hydro transmissions 618-04164A and 618-04327 which are no longer available. The replacement transmission has a Double-D axle end which requires a Double-D wheel hub assembly. A new neutral return spring is enclosed for the RH transmission. See instructions on page 2 of this sheet.

NOTE: These materials are prepared for use by trained technicians who are experienced in the service and repair of equipment of the kind described in this publication, and are not intended for use by untrained or inexperienced individuals. Such individuals should seek the assistance of an authorized service technician or dealer.

NOTE: Save this Instruction Sheet. Refer to it when ordering replacement parts.

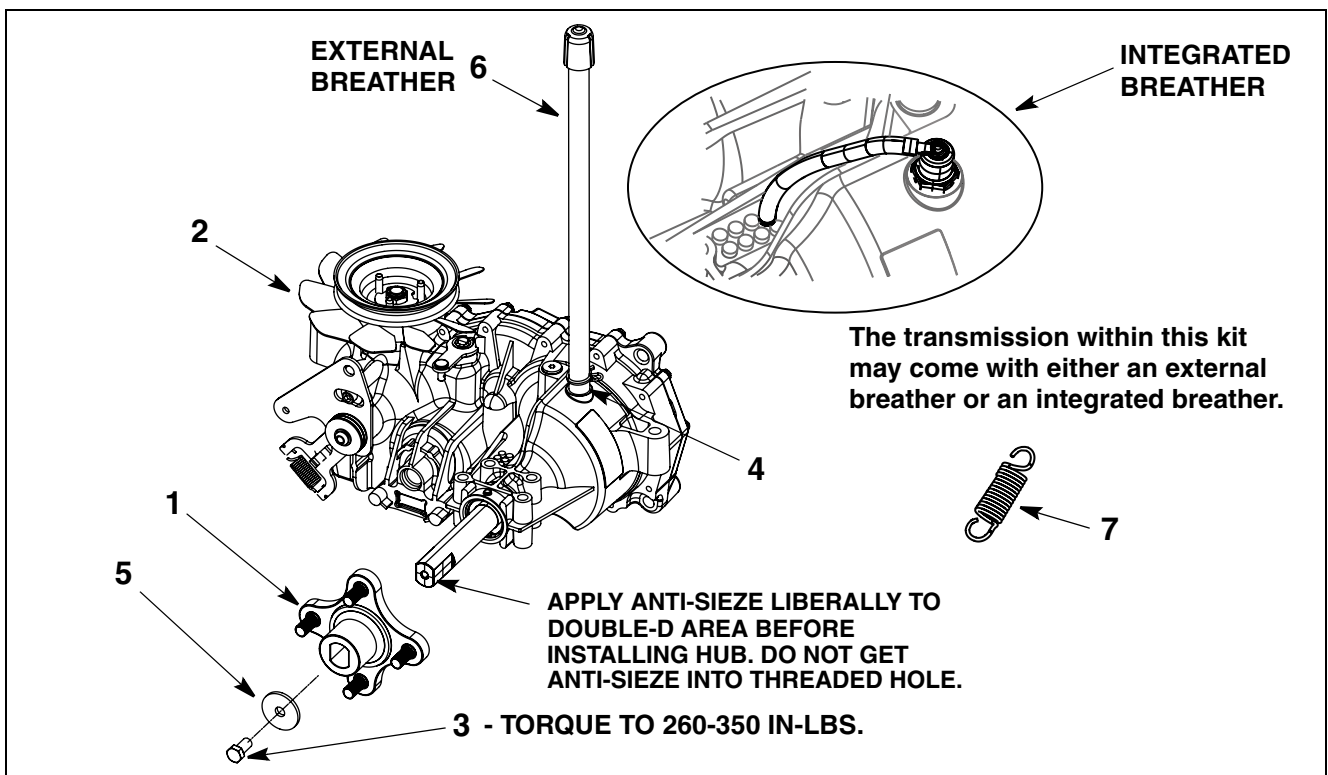

FIGURE 1

Service Kit Contents

(See Figure 1)

ITEM NO.	PART NUMBER	QTY	DESCRIPTION
1	618-04494	1	HUB ASM:WHL:DOUBLE-D SHORT
2	618-04431A	1	TRANS ASM:HYDRO:EZT:LH
3	710-3119	1	SCREW:3/8"-16 x .750:GR5:LOCK
4	726-04059	1	CLAMP:HOSE: .750
5	736-0227	1	WASHER:FLAT: .390 x 1.50 x .134
6	751-10474	1	HOSE: BREATHER: EXTERNAL
7	732-04448	1	SPRING: EXTENSION (See page 2)
8	*	1	THIS INSTRUCTION SHEET

* - Not Available Separately

Installation of Loose Packed Extension Spring:

1. A Neutral Return Extension Spring, Item 7, is supplied with this kit for installation on the remaining hydrostatic transmission when only one hydrostatic transmission is being replaced.
2. This spring, Item 7, must be installed on the remaining hydrostatic transmission in order for both transmissions to come to neutral at the same rate.
3. See Figure 2 for location of the neutral return mechanism.

5. Install the new Neutral Return Spring, Item 7, onto the two as shown in Figure 3.
6. When complete both installed transmissions must have the same color neutral return spring.
7. This completes the installation of the new Neutral Return Spring onto the remaining original transmission.

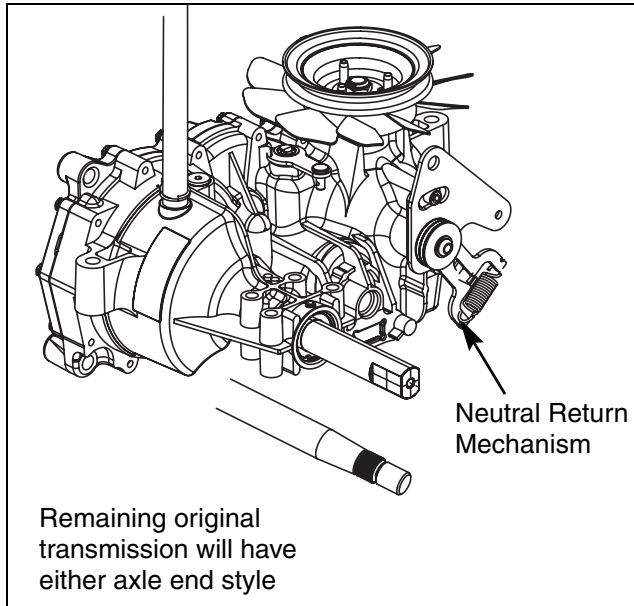

FIGURE 2

4. With a suitable set of pliers or spring removal tool, remove and discard the existing spring from the neutral return mechanisms two arms on the remaining (not replaced with this kit) hydrostatic transmission. See Figure 3.

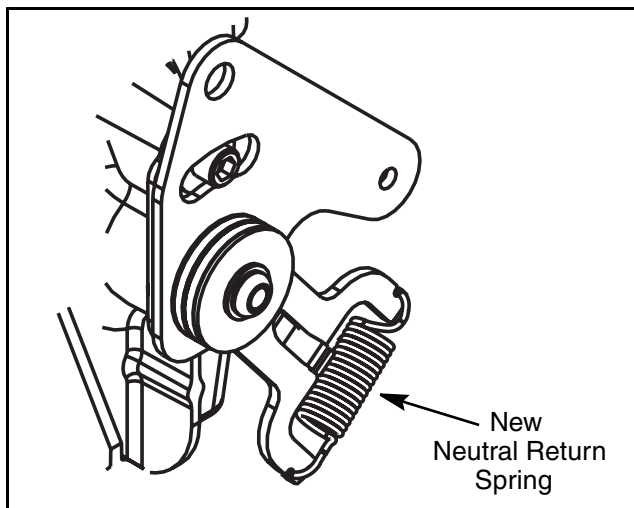

FIGURE 3



Service Kit 759-04143

Date: 11/21/2006

Subject: Service Replacement for the
42" RZT Right Hand (RH)
Hydro Transmission

Models N/A
Affected:

PURPOSE: This service kit replaces the RH hydro transmissions 618-04163A and 618-04326 which are no longer available. The replacement transmission has a Double-D axle end which requires a Double-D wheel hub assembly. A new neutral return spring is enclosed for the LH transmission. See instructions on page 2 of this sheet.

NOTE: These materials are prepared for use by trained technicians who are experienced in the service and repair of equipment of the kind described in this publication, and are not intended for use by untrained or inexperienced individuals. Such individuals should seek the assistance of an authorized service technician or dealer.

NOTE: Save this Instruction Sheet. Refer to it when ordering replacement parts.

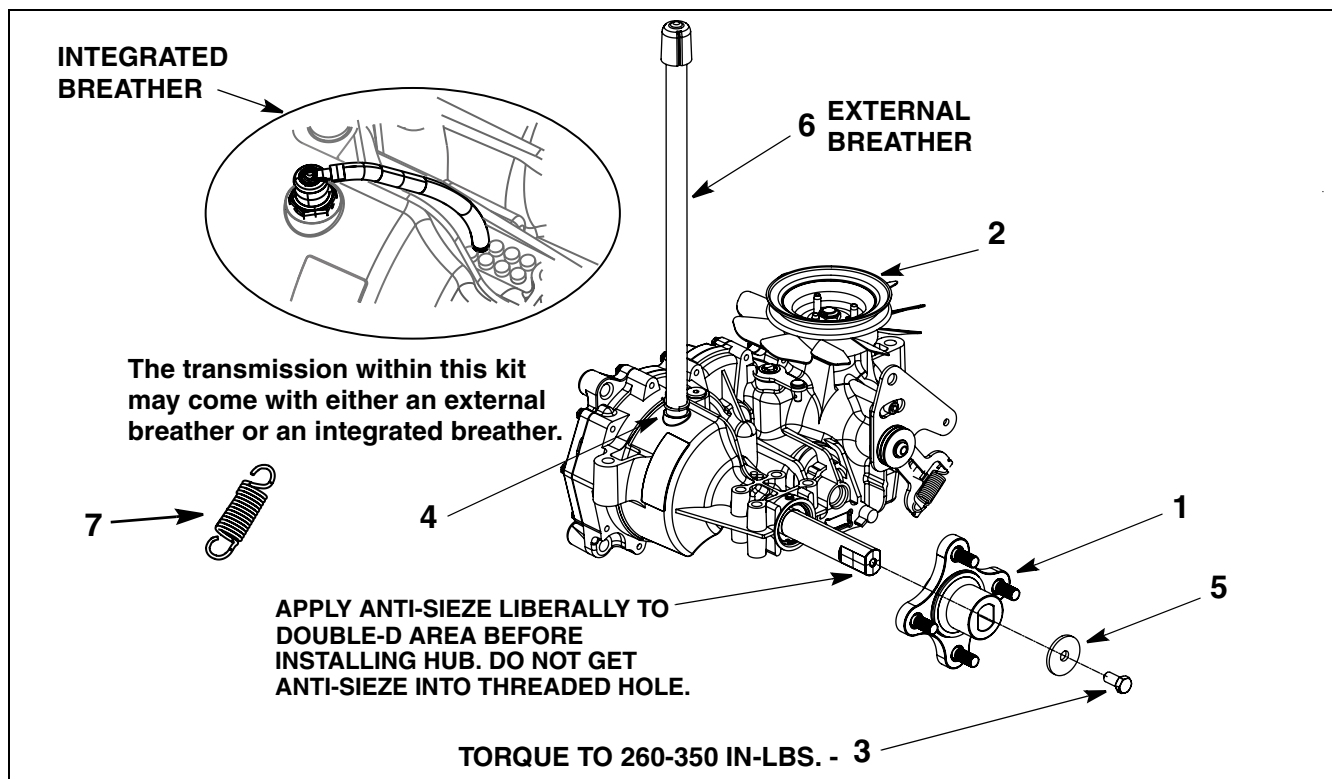

FIGURE 1

Service Kit Contents

(See Figure 1)

ITEM NO.	PART NUMBER	QTY	DESCRIPTION
1	618-04494	1	HUB ASM:WHL:DOUBLE-D SHORT
2	618-04432A	1	TRANS ASM:HYDRO:EZT:RH
3	710-3119	1	SCREW:3/8"-16 x .750:GR5:LOCK
4	726-04059	1	CLAMP:HOSE: .750
5	736-0227	1	WASHER:FLAT: .390 x 1.50 x .134
6	751-10474	1	HOSE: BREATHER: EXTERNAL
7	732-04448	1	SPRING: EXTENSION (See page 2)
8	*	1	THIS INSTRUCTION SHEET

* - Not Available Separately

Installation of Loose Packed Extension Spring:

1. A Neutral Return Extension Spring, Item 7, is supplied with this kit for installation on the remaining hydrostatic transmission when only one hydrostatic transmission is being replaced.
2. This spring, Item 7, must be installed on the remaining hydrostatic transmission in order for both transmissions to come to neutral at the same rate.
3. See Figure 2 for location of the neutral return mechanism.

5. Install the new Neutral Return Spring, Item 7, onto the two arms as shown in Figure 3.
6. When complete both installed transmissions must have the same color neutral return spring.
7. This completes the installation of the new Neutral Return Spring onto the remaining original transmission.

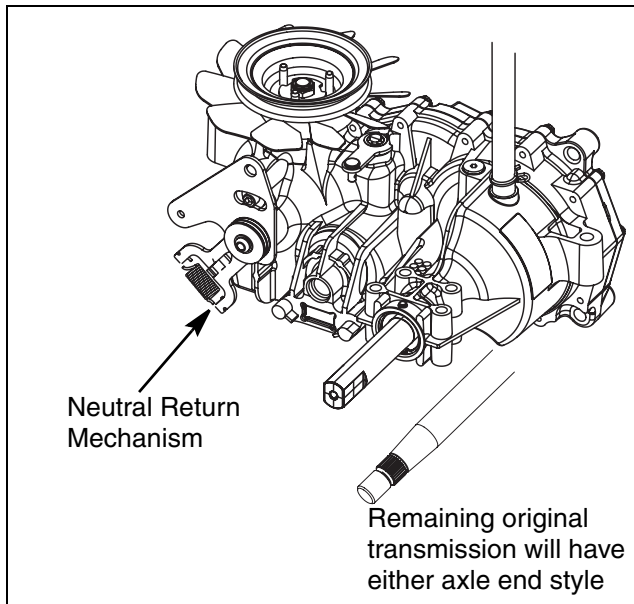

FIGURE 2

4. With a suitable set of pliers or spring removal tool, remove and discard the existing spring from the neutral return mechanisms two arms on the remaining (not replaced with this kit) hydrostatic transmission. See Figure 3.

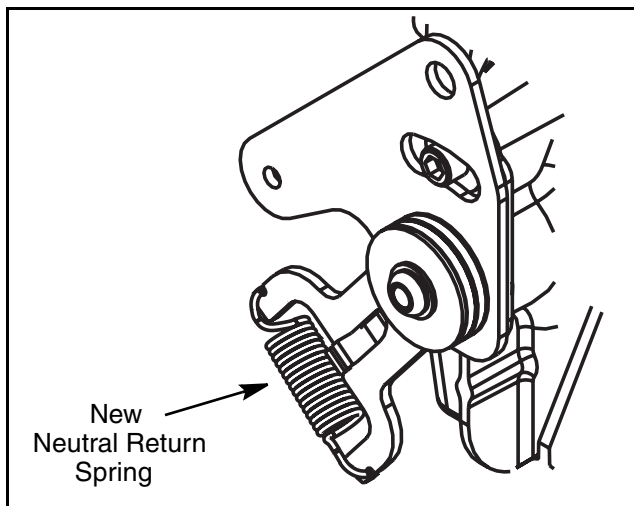

FIGURE 3