



Service Kit

753-05097

Date: 9/14/2005

Subject: Adapter Kit for OEM-190-823 Snow Thrower Attachment

Models Affected: Fast Attach OEM-190-823 42" 2-Stage Snow Thrower Attachment

Read through and understand these instructions completely before proceeding with repair.

PURPOSE:

This kit adapts the OEM-190-823 42" 2-Stage Snow Thrower Attachment's Undercarriage Assembly to be compatible with the **2005 and later 600-649 Series and 700-799 Series lawn tractors with Step-Thru frame and 38" or 42" cutting decks that are engaged with a cable style deck engagement manual PTO.** It also provides the mounting tractor side brackets, upper belt and belt keeper required for the 700-799 Series lawn tractors.

This service kit in combination with an OEM-190-823 42" 2-Stage Snow Thrower Attachment is the same as an OEM-190-032 42" 2-Stage Snow Thrower Attachment.

NOTE: *These materials are prepared for use by trained technicians who are experienced in the service and repair of equipment of the kind described in this publication, and are not intended for use by untrained or inexperienced individuals. Such individuals should seek the assistance of an authorized service technician or dealer.*

NOTE: *Save this Instruction Sheet. Refer to it when ordering replacement parts.*

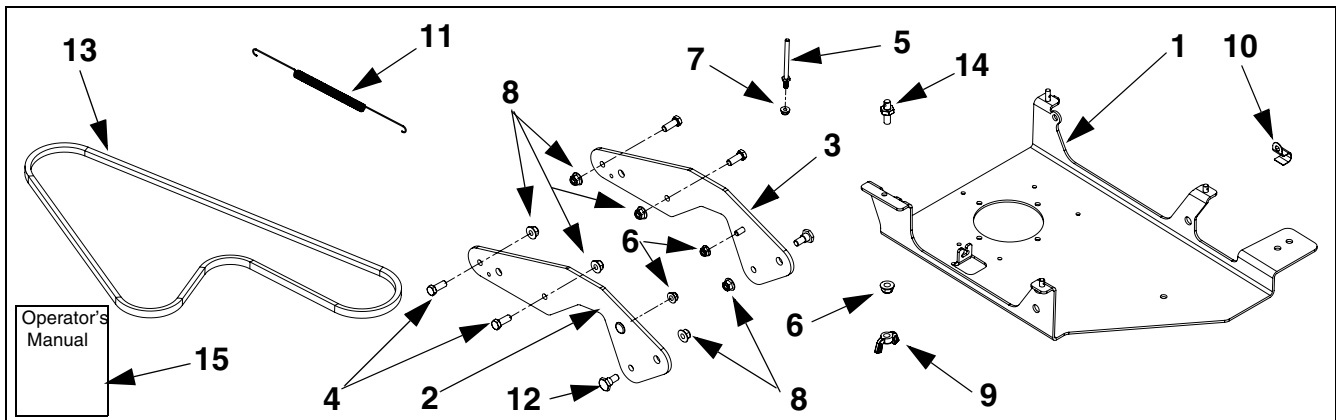

FIGURE 1

Service Kit Contents
(See Figure 1)

ITEM NO.	PART NUMBER	QTY	DESCRIPTION
1	683-04210	1	BRACKET: ASSEMBLY: UNDERCARRIAGE
2	683-04214	1	BRACKET: ASSEMBLY: SNOW LT-5 RH
3	683-04215	1	BRACKET: ASSEMBLY: SNOW LT-5 LH
4	710-0514	4	SCREW: HEX HD: 3/8"-16 x 1.00: GR5: STD
5	711-1000	1	KEEPER: BELT: .25 DIA x 3.0
6	712-04063	3	NUT: FLANGELOCK: 5/16"-18: GRF: NYLON
7	712-04064	1	NUT: FLANGELOCK: 1/4"-20: GRF: NYLON
8	712-04065	6	NUT: FLANGELOCK: 3/8"-16: GRF: NYLON
9	712-04100	1	NUT: WING: 5/16"-18 NYLOK
10	726-0354	1	CLAMP: 16MM
11	732-04237	1	SPRING: EXTENSION: .50 DIA x 12.00 LG
12	738-0143	2	SCREW: SHOULDER: .498 x .340: 3/8"-16
13	754-0498	1	BELT: V TYPE: A SECTION x 66.90"
14	710-04511	1	PIN: 5/16"-18
15	769-01933A	1	MANUAL: OPERATOR'S: OEM-190-032
16	769-02072	1	THIS INSTRUCTION SHEET

Determine the Model of Your Rider:

Locate the rider's model plate located under the seat. Simply flip the seat up to find the model plate attached to the underside of the seat.

The model number consists of an 11 digit/letter combinations. The 5th, 6th and 7th characters from the left in the model number determine the model series rider.

Confirm that the rider model series and model year matches those defined in the **PURPOSE** section above.

Pre-service Preparation:

1. Place tractor on a firm and level surface, set the parking brake to the ON position and place the PTO lever in the disengaged (OFF) position.

2. Turn off engine, remove key and allow engine and muffler to cool.

NOTE: Reference to the left and right sides of the tractor are determined when in the operator's position facing forward. Reference to the FRONT indicates the grille end; to the REAR indicates the drawbar (hitch) end.

3. Familiarize yourself with the parts/assemblies of the OEM-190-823 snow thrower (hereafter referred to as "823") from the Operator's Manual and the contents and assembly instructions of this kit.

4. In order to operate the 823 snow thrower on a 2005 and later 600-649 Series AutoDrive and 700-799 Series lawn tractors, the 823 undercarriage must be stripped of it's hardware and transferred to the Undercarriage Bracket assembly, Item 1, of this kit.

New Undercarriage Bracket Assembly:

5. Locate the 823 Undercarriage Assembly (w/upper belt) from the 823 accessory packaging.

6. Remove and retain the clevis pins and hair pins, spindle assembly (618-0411), the three (3) belt keepers (711-1000), idler pulley (756-0981A) and belt guard (732-1013), dual idler bracket (784-5727) with pulleys and spacers assembly, spring (732-0978) and its' attach bolt and all securing hardware. See Figure 2.

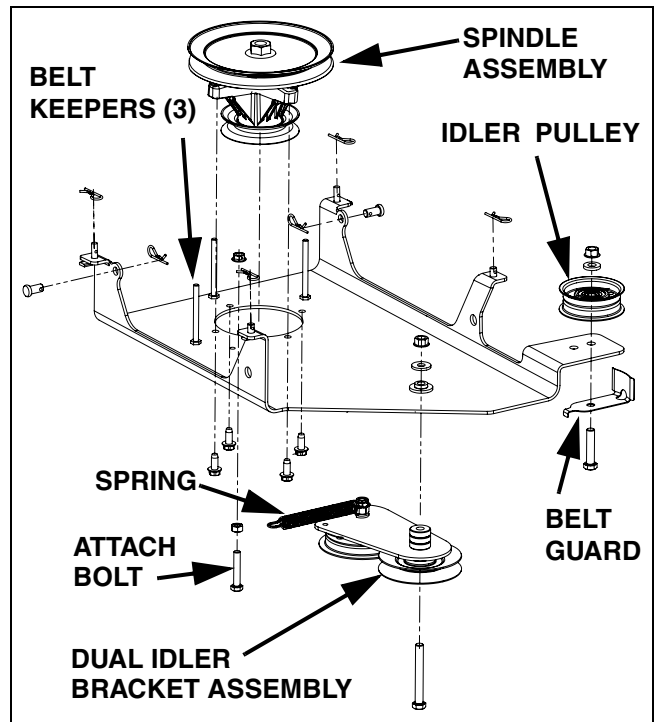

FIGURE 2

7. If the snow thrower is to be mounted to a 2005 or later 600-649 Series lawn tractor having the cable style deck engagement PTO, select "V" Belt, 754-0481 from the 823 accessory package.

If the snow thrower is to be mounted to a 2005 or later 700 -799 Series lawn tractor having the cable style deck engagement PTO, select "V" Belt, 754-0498 from the 753-05097 service kit package.

8. Install the three belt keepers removed from the 823 undercarriage assembly onto the new Undercarriage Bracket Assembly, Item 1, of this kit in the same locations as on the 823 undercarriage. See Figure 3.

9. Place the correct belt, as determined in Step 7, around the large pulley on the spindle assembly, removed from the 823 undercarriage assembly, and mount the spindle assembly to the new Undercarriage Plate, Item 1. The belt keepers will retain the belt on the spindle pulley. Ensure the belt is between the belt keepers and the pulley "V".

10. Install the remaining components removed from the 823 undercarriage assembly onto the new Undercarriage Bracket Assembly, Item 1. Ensure that all components are assembled in the same position as was on the 823 undercarriage. See Figure 3. Tighten all mounting hardware except bolt "A" and nut "B". See Figure 3.

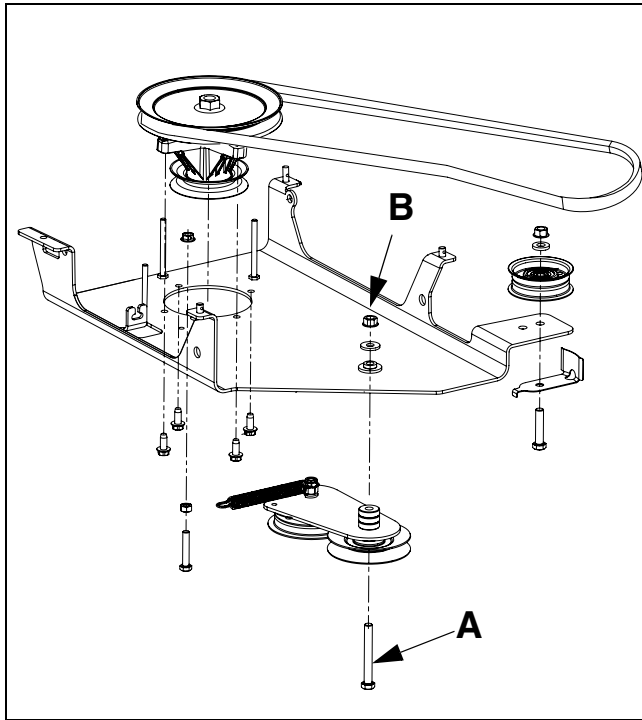

FIGURE 3

11. Locate the idler assembly with extension spring packed separately with the 823 accessory. See Figure 4 inset.

12. Remove the extension spring from the idler assembly and mount the idler assembly as shown in Figure 4. Tighten bolt "A" and nut "B". Ensure the idler pivots freely.

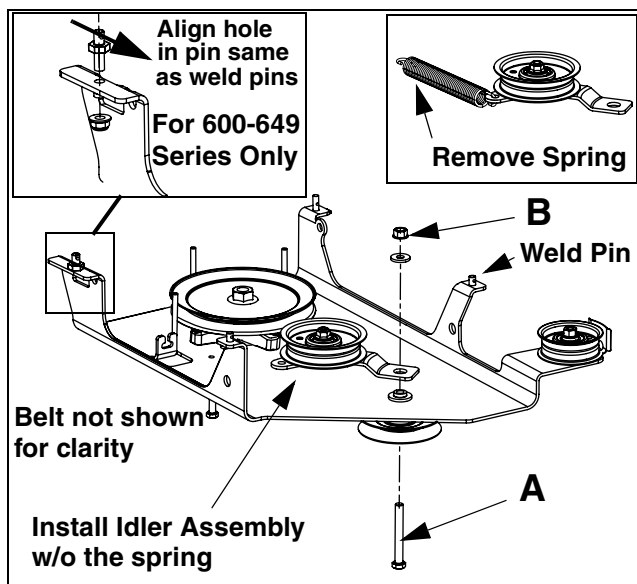

FIGURE 4

13. If the snow thrower is to be mounted to a 2005 or later 600-649 Series lawn tractor having the cable style deck engagement PTO, proceed to Step 14.

If the snow thrower is to be mounted to a 2005 or later 700 -799 Series lawn tractor having the cable style deck engagement PTO, proceed to Step 15.

14. From the 753-05097 Service Kit contents locate and install the Threaded Pin, Item 14, and Flange Lock Nut, Item 6, onto the new Undercarriage Bracket Assembly, Item 1, as shown in Figure 4 Inset. Proceed to Step 16.

15. From the 753-05097 Service Kit contents locate and install the Belt Keeper, Item 5, and Flange Lock Nut, Item 7, as shown in Figure 5. Ensure the belt is between the belt keeper and the spindle's "V" pulley.

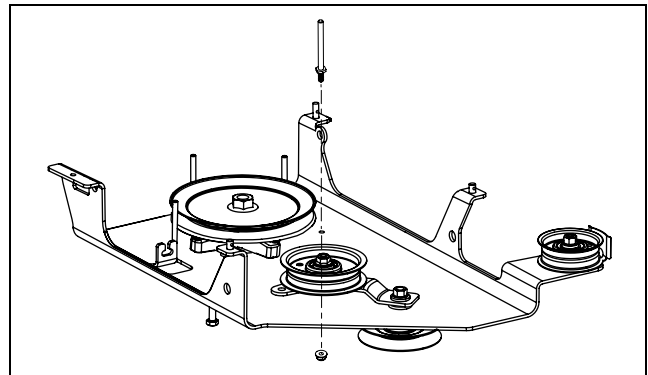

FIGURE 5

16. Pre-assembly of the undercarriage per this instruction sheet is complete. Continue assembly and snow thrower installation using the OEM-190-032 Operator's Manual, Item 15, included in this service kit as follows:

If the snow thrower is to be mounted to a 2005 or later 600-649 Series lawn tractor having the cable style deck engagement PTO, continue installation from OEM-190-032 Operator's Manual, Section 4, page 11, Step 4.

If the snow thrower is to be mounted to a 2005 or later 700 -799 Series lawn tractor having the cable style deck engagement PTO, continue installation from OEM-190-032 Operator's Manual, Section 5, pages 14 and 15.

NOTE: Some undercarriage assembly detailed in the OEM-190-032 Operator's Manual, Section 5, pages 14 and 15 has already been performed by this service kit. Read through Section 5 and note of what steps are already accomplished.

NOTE: The remaining service kit parts will be needed to complete the installation of the snow thrower per the OEM-190-032 Operator's Manual.

NOTES