



Service Kit 753-06148

Date: 3/24/2009

Subject: Rear Attachment Support Brackets for the 700 Series Lawn Tractor.

Models Affected: See PURPOSE below.

REF: CC-190-670

Read through and understand these instructions completely before proceeding with repair.

PURPOSE: This service kit provides weight distribution support brackets for the 700 Series Lawn Tractors using the OEM-190-180 Rear Bagger Attachment. These brackets replace the 2 hole brackets 783-04137A and 783-04132A that may be supplied with the bagger attachment.

NOTE: These materials are prepared for use by trained technicians who are experienced in the service and repair of equipment of the kind described in this publication, and are not intended for use by untrained or inexperienced individuals. Such individuals should seek the assistance of an authorized service technician or dealer.

NOTE: Save this Instruction Sheet. Refer to it when ordering replacement parts.

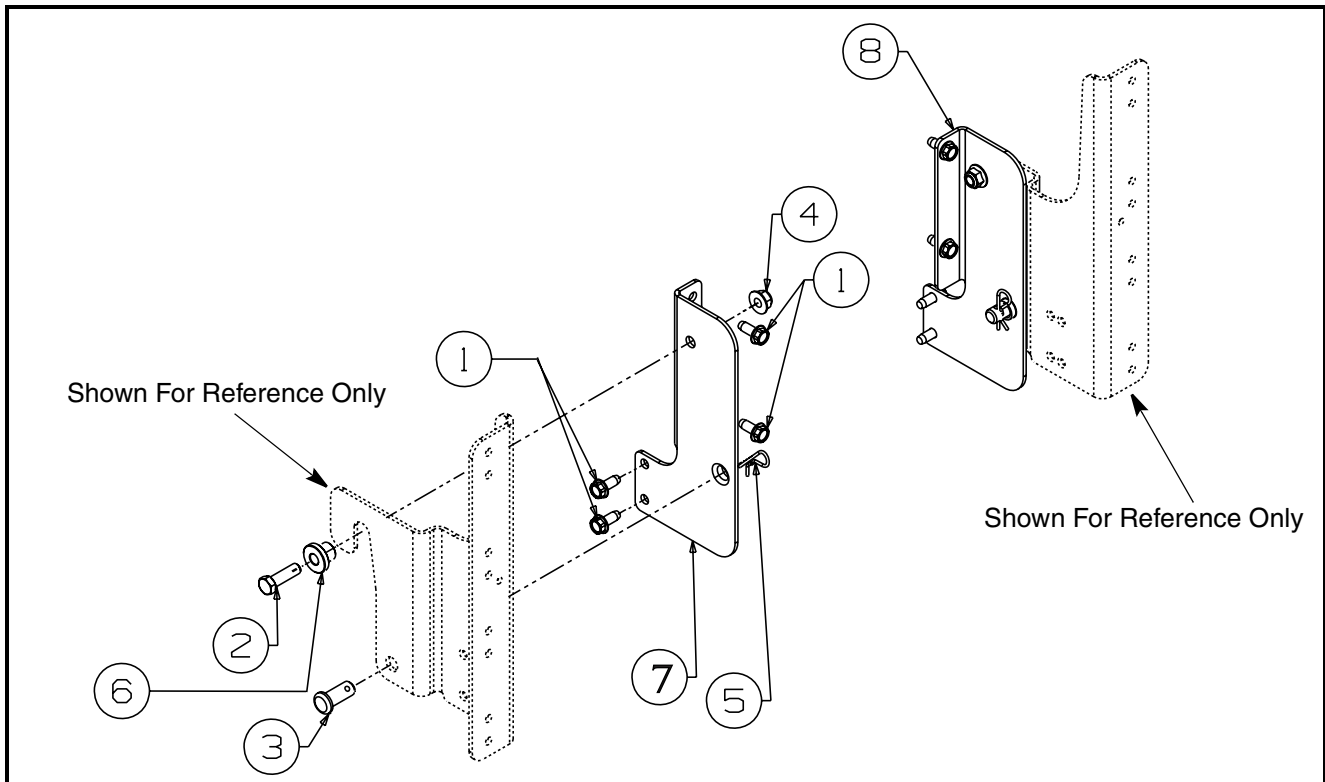

FIGURE 1

Service Kit Contents (See Figure 1)

* - Not Available Separately

ITEM NO.	PART NUMBER	QTY	DESCRIPTION
1	710-1260A	8	SCREW:TT: 5/16"-18 x .750":HXINDWSH
2	710-3005	2	SCREW:HHCS:3/8"-16 x 1.25":GR5:STD
3	711-0310	2	PIN:CLEVIS: .50" DIA. x 1.18" LG
4	712-04065	2	NUT:FLANGELOCK:3/8"-16:GRF:NYLON
5	714-0145	2	PIN:COTTER:INTERNAL: .092" x 1.64" LG
6	738-04058	2	SPACER:SHOULDER: .38" x 1.0" x .70"
7	783-04919	1	BRACKET:MOUNTING: LH/RR
8	783-04968	1	BRACKET:MOUNTING:RH/RR
9	*	1	THIS INSTRUCTION SHEET