

General Purpose Engine

(GC04-4400001 FORWARD)

GX240K1

(TYPE QA2, VOLUME 2 OF 2)

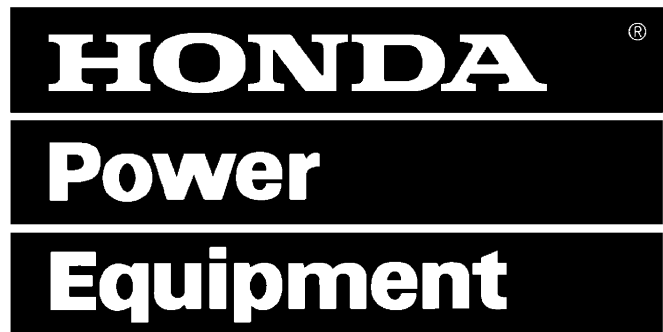

Parts Catalog

MAY, 2006

American Honda Motor Co., Inc.

For Discount Troy Bilt Parts Call 606-678-9623 or 606-561-4983

TABLE OF CONTENTS

Introduction

Grid / Page

- HOW TO USE THIS CATALOG A2 4
- SERIAL NUMBERS A3 6
- BULK HOSE PART NUMBER PATTERN..... A3 7
- MASTER INDEX A4 8

Part Groups

- ENGINE SECTION 1-C1 1-1

Index

- PART NUMBER INDEX B1 2-1
- DESCRIPTION INDEX 1-E1 3-1

HOW TO USE THIS CATALOG

CATALOG/CATALOGUE PAGE BREAKDOWN (Generic layout-sample data only)

MODEL		TYPE								(11)
A = MODEL		a=TYPE								B-1
B = MODEL		b=TYPE								
C = MODEL		c=TYPE								
(4)										
Ref	Description	(3) Mod	(6) Type	Engine Serial Number		ORG	QTY	Part Number	H/C	
1	COVER SET, CYLINDER HEAD	4	b	15240057	-----	JPN	1	12310-PE2-020	2031797	
	COVER SET, CYLINDER HEAD			-----	12234811	USA	1	12310-PE2-030	2210888	
(1)	(2)			(5)		(7)	(8)	(9)	(10)	

KEY TO CATALOG/CATALOGUE PAGE BREAKDOWN

1. Ref - Reference numbers correspond to the reference numbers on the illustrations. All illustrations are representative only, and do not necessarily look exactly like the actual part. "NI" signifies the part is not illustrated. Reference numbers may be skipped when they apply to other models.

2. Description* - Describes the part for the related part number.

Abbreviations:

- | | |
|--------------------------|---------------------------------------------|
| ASSY. - Assembly | A.C. - Alternating Current |
| L(100L) - Link(100Links) | D.C. - Direct Current |
| R. - Right | KPH - Kilometers Per Hour |
| L. - Left | MPH - Miles Per Hour |
| IN. - Inlet | A.M. - Attaching Mark |
| EX. - Exhaust | T.M. - Transcript Mark |
| FR. - Front | A - Ampere |
| RR. - Rear | WL - With Labeling |
| HEX. - Hexagonal | WOL - Without Labeling |
| STD. - Standard | T (22T) - Tooth |
| MM - Millimeter | C.D.I. - Capacitive Discharge Ignition |
| G - Gram | G.F.C.I. - Ground Fault Circuit Interruptor |
| V - Volt | |
| W - Watt | |

3. Mod* - Model alpha labeling is unique per catalog/catalogue (not consistent with other catalogs/catalogues).

4. Each model and type in the catalog/catalogue is represented by an alpha label.

5. Serial Number - Applies to Engine or Frame serial numbers depending on the section. The serial numbers of a unit (frame, engine, carburetor) should be checked prior to ordering parts for the unit. In cases where a part has been modified, the beginning and/or ending serial number of the unit bearing the modification is listed in the "SERIAL NUMBER" column. Modification parts can be controlled by three types of numbers as described below.

Engine serial number - Engine group parts (Block numbers beginning with "E").

Carburetor identification number - Carburetor component parts.

Frame serial number - Frame group parts (Block numbers beginning with "F").

Note 1 - A modification that does not follow the pattern above will be clarified by a comment located below the part description. A serial number chart and a guide to serial number locations are provided in the front portion of the catalog/catalogue.

Note 2 - Although most models will be identified by Engine and Frame serial numbers, some models may be identified by one serial number only - either Engine serial number or Frame serial number.

6. Type* - Model Type is defined in the serial number chart.

7. ORG* - Manufacturing country of origin of the unit.

8. QTY - Quantity required for the specified Block/Section.

A. "AR" in place of the quantity indicates AS REQUIRED.

B. "(" Parentheses in the quantity indicate "optional".

9. Part Number - Part number corresponds to the reference number and application. Several part numbers may be listed under one (1) reference number.

Note: For U.S. only - For your convenience the current supersede chain, as of print date, has been listed. Supersede chains are subject to change without notice.

10. H/C - The Honda Code and Part Number share a 1 to 1 relationship (U.S.A. only).

11. The Block Number identifies the catalog/catalogue section.

CONSTRUCTION OF PART NUMBERS

All parts are classified into two groups, "GENERAL PARTS" and "STANDARD PARTS". All parts are numbered according to the system described below:

General Parts

Example: Driver Seat Assembly Part No. 77400-634-671ZA
 Function No. 77
 Component No. 400
 Model Code No. -634-
 Modification Process Design 671
 Color/colour Indicator** ZA

Standard Parts

Example: 8 x 18 Hex. bolt Part No. 92000-08018-0A
 Function No. 92000
 Dimensions -08018-
 ISO Standard Designation 0
 Chemical Surface Treatment A

**The color/colour indicator at the end of a part number signifies a color/colour. These color/colour indicators such as ZA, ZB, ZC . . . , except ZZ, do not identify the actual color/colour. Actual colors/colours are identified by a code that appears between asterisks in the part description.

Additional Information - The section index located at the bottom of each microfiche grid lists section titles. The Engine and Frame sections have separate section indexes.

Some Block Titles are numbered, such as Air Cleaner (1), Air Cleaner (3), Muffler (2) or Muffler (4), etc. These may skip numbers when some blocks apply in other volumes of the same model(s).

*When columns become full, additional data is displayed on a second line.

This page intentionally left blank.

SERIAL NUMBERS

Models and applicable serial numbers

Models and applicable serial numbers given in this parts catalog can be identified as follows.

Model	Type	Applicable Engine Serial No.	Applicable Frame Serial No.	Applicable Carburetor Identification
GX240K1	QA2	GC04-4400001~	—	BE70B B

BULK HOSE PART NUMBER PATTERN

Construction of Fuel and Vacuum Hose Part Number

Example: 9 5 0 0 1 - 7 5 0 0 1 - 4 0 M

Roll Hose

All roll hose part numbers have an "M" in this position

Appearance Code

Fuel Hose:

- 2 = Red, braided exterior
- 3 = Red
- 4 = Ash Gray with red stripe
- 5 = Black, braided interior
- 6 = Black

Vinyl Hose:

- 1 = Ash Gray
- 2 = Black
- 3 = Light Red
- 6 = Light Red
- 7 = Pale Black

Vacuum Hose:

- 1 = Ash Gray
- 2 = Ash Gray
- 3 = Black
- 5 = Black

Length

Cut Hose length is in *Millimeters (mm)*

Bulk Hose length is in *Meters (M)*

Inside Diameter

Fuel and Vacuum Hose

- | | |
|-----------------------|------------------------------|
| 35 = 3.5 mm | 11 = 11 mm |
| 45 = 4.5 mm | 91 = 12 (outside dia. 15) mm |
| 50 = 5.0 mm | 92 = 12 (outside dia. 16) mm |
| 55 = 5.3 mm or 5.5 mm | 12 = 12 (outside dia. 17) mm |
| 65 = 6.5 mm | 14 = 14 mm |
| 70 = 7.0 mm | 17 = 17 mm |
| 75 = 7.3 mm or 7.5 mm | |
| 80 = 8.0 mm | |

ID./OD. Code : Vinyl Hose

- | | | |
|--------------------------|----------------------------|----------------------------|
| 01 = ID. 2.9, OD. 6.8 mm | 14 = ID. 6.0, OD. 9.0 mm | 37 = ID. 11.0, OD. 15.0 mm |
| 03 = ID. 3.0, OD. 6.0 mm | 17 = ID. 7.0, OD. 9.0 mm | 38 = ID. 12.0, OD. 13.0 mm |
| 05 = ID. 3.5, OD. 6.5 mm | 19 = ID. 7.0, OD. 11.0 mm | 39 = ID. 12.0, OD. 14.0 mm |
| 07 = ID. 4.0, OD. 7.0 mm | 21 = ID. 8.0, OD. 9.0 mm | 40 = ID. 12.0, OD. 16.0 mm |
| 08 = ID. 4.5, OD. 6.5 mm | 23 = ID. 8.0, OD. 12.0 mm | 43 = ID. 13.0, OD. 15.0 mm |
| 09 = ID. 4.5, OD. 8.0 mm | 25 = ID. 9.0, OD. 11.0 mm | 45 = ID. 14.0, OD. 18.0 mm |
| 12 = ID. 5.0, OD. 7.0 mm | 27 = ID. 9.0, OD. 13.0 mm | 50 = ID. 16.0, OD. 19.0 mm |
| 10 = ID. 5.0, OD. 8.0 mm | 33 = ID. 10.0, OD. 14.0 mm | 55 = ID. 17.5, OD. 20.5 mm |
| 11 = ID. 5.0, OD. 9.0 mm | 36 = ID. 11.0, OD. 13.0 mm | 60 = ID. 22.0, OD. 27.0 mm |

Hose Type:

- 1 = Fuel Hose
- 3 = Vinyl Hose
- 5 = Vacuum Hose

CAUTION: Never use vacuum / or vinyl hose in place of fuel hose or vice versa

MASTER INDEX

Title	Grid	Page	Title	Grid	Page
ENGINE SECTION					
CYLINDER HEAD	1-C1	1-2			
CYLINDER	1-C2	1-4			
CRANKCASE COVER (1)	1-C2	1-5			
CRANKSHAFT	1-C3	1-7			
PISTON	1-C4	1-8			
CAMSHAFT	1-C4	1-9			
RECOIL STARTER (1)	1-C5	1-10			
FAN COVER (1)	1-C6	1-12			
CARBURETOR (4)	1-C6	1-13			
AIR CLEANER (3)	1-C8	1-16			
MUFFLER (2)	1-C8	1-17			
FUEL TANK (3)	1-D1	1-18			
FLYWHEEL	1-D1	1-19			
IGNITION COIL	1-D2	1-20			
CONTROL	1-D2	1-21			
LABEL	1-D3	1-23			
TOOLS (1)	1-D4	1-24			

ENGINE SECTION
Chapter Table of Contents

Page Title	Grid	Page
CYLINDER HEAD	1-C1	1-2
CYLINDER	1-C2	1-4
CRANKCASE COVER (1).....	1-C2	1-5
CRANKSHAFT	1-C3	1-7
PISTON	1-C4	1-8
CAMSHAFT.....	1-C4	1-9
RECOIL STARTER (1)	1-C5	1-10
FAN COVER (1)	1-C6	1-12
CARBURETOR (4)	1-C6	1-13
AIR CLEANER (3).....	1-C8	1-16
MUFFLER (2)	1-C8	1-17
FUEL TANK (3).....	1-D1	1-18
FLYWHEEL	1-D1	1-19
IGNITION COIL.....	1-D2	1-20
CONTROL.....	1-D2	1-21
LABEL	1-D3	1-23
TOOLS (1).....	1-D4	1-24

CYLINDER HEAD

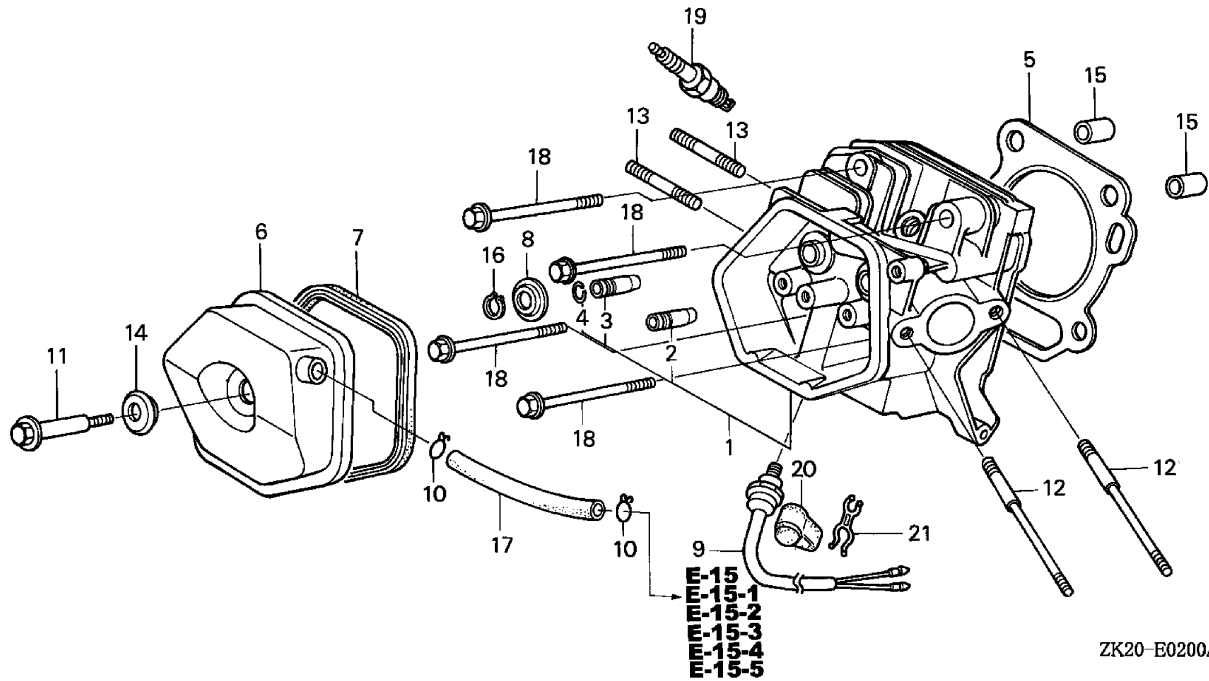

ZK20-E0200A

ZK20E0200A

MODEL
A =GX240K1

TYPE
a =QA2

E-2

Ref	Description	Engine Serial Number		QTY	Part Number	H/C
		From	To			
1	CYLINDER HEAD.....	-----	-----	1	12200-ZH9-405	7603483
2	GUIDE, VALVE (OS)	-----	-----	(1)	12204-ZE2-306	4179164
3	GUIDE, EX. VALVE (OS)	-----	-----	(1)	12205-ZE2-305	2089563
4	CLIP, VALVE GUIDE	-----	-----	1	12216-ZE2-300	2089597
5	GASKET, CYLINDER HEAD	-----	-----	1	12251-ZE2-800	3678539
6	COVER, HEAD.....	-----	-----	1	12310-ZE2-020	4300885
7	GASKET, CYLINDER HEAD COVER	-----	-----	1	12391-ZE2-020	4300893
8	SEAT, VALVE SPRING	-----	-----	1	14775-ZE2-010	2157485
11	BOLT, HEAD COVER.....	-----	-----	1	90014-ZE2-000	2027035
12	BOLT, STUD (8X123).....	-----	-----	2	90042-ZE2-000	2027043
13	BOLT 2, STUD (8X32)	-----	-----	2	92900-08032-0E	2663433
14	WASHER, HEAD COVER	-----	-----	1	90441-ZE2-010	2293918
15	PIN A, DOWEL (12X20)	-----	-----	2	94301-12200	0165324
17	BULK HOSE, VACUUM (11X1000) (11X100).....	-----	-----	1	95005-11001-30M	4537312
18	BOLT, FLANGE (10X80)	-----	-----	4	95701-10080-00	2545341
19	SPARK PLUG (BPR5ES) (NGK)	-----	-----	(1)	98079-55846	1672443
	SPARK PLUG (W16EPR-U) (DENSO).....	-----	-----	(1)	98079-55855	1672450

CYLINDER HEAD

MODEL **TYPE**
 A =GX240K1 a =QA2

E-2

Ref	Description	Engine Serial Number		QTY	Part Number	H/C
		From	To			
19	SPARK PLUG (BPR6ES) (NGK)	-----	-----	1	98079-56846	1441112
	SPARK PLUG (W20EPR-U) (DENSO).....	-----	-----	1	98079-56855	1441120

CYLINDER

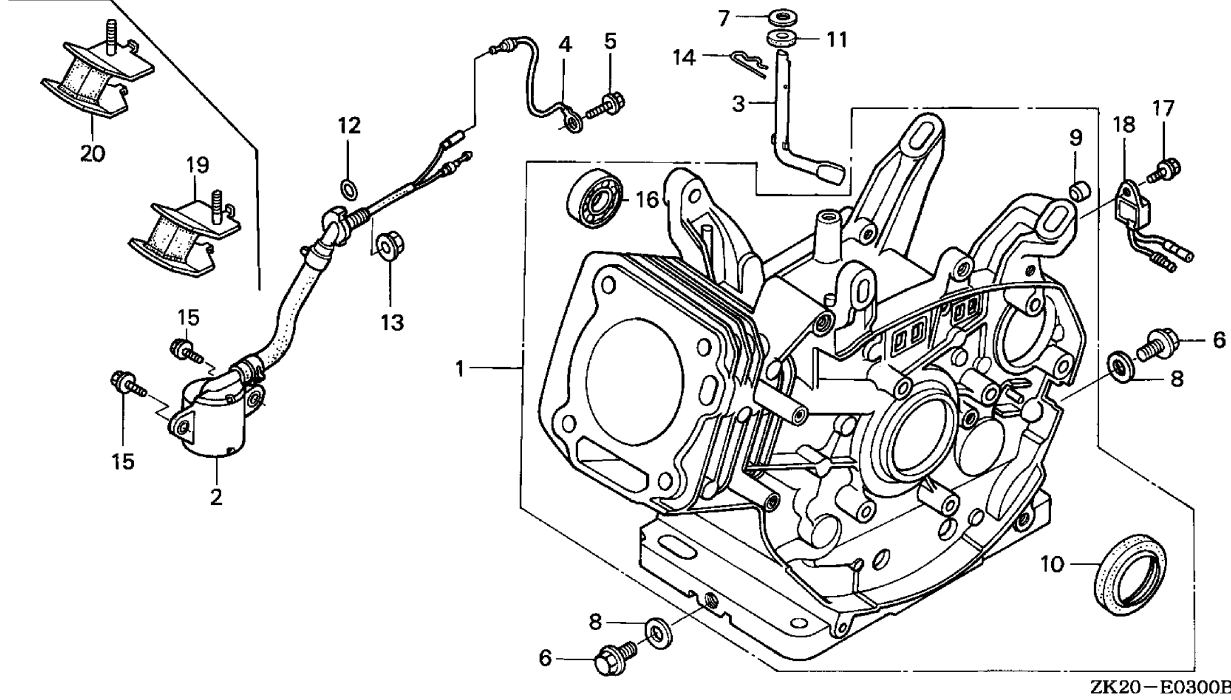

ZK20-E0300B

ZK20E0300B

MODEL
A =GX240K1

TYPE
a =QA2

E-3

Ref	Description	Engine Serial Number		QTY	Part Number	H/C
		From	To			
1	CYLINDER ASSY. (BALANCER+OIL ALERT).....	-----	-----	1	12000-ZE2-408	7759624
2	SWITCH ASSY., OIL LEVEL	-----	-----	1	15510-ZE2-043	5792361
3	SHAFT, GOVERNOR ARM	-----	-----	1	16541-ZE2-010	4723227
6	BOLT, DRAIN PLUG	-----	-----	2	90131-896-650	1986231
7	WASHER (8.2X17X0.8)	-----	-----	1	90446-KE1-000	2027134
8	WASHER, DRAIN PLUG (12MM).....	-----	-----	2	94109-12000	0171868
10	OIL SEAL (30X46X8)	-----	-----	1	91201-890-003	0756494
12	O-RING (13.5X1.5) (ARAI)	-----	-----	1	91353-671-003	0949883
13	NUT, FLANGE (10MM).....	-----	-----	1	94050-10000	0483867
14	PIN, LOCK (10MM).....	-----	-----	1	94251-10000	0159269
15	BOLT, FLANGE (6X12)	-----	-----	2	95701-06012-00	2105799
16	BEARING, RADIAL BALL (6202)	-----	-----	1	96100-62020-00	0708941
17	BOLT, FLANGE (6X12) (CT200)	-----	-----	1	90013-883-000	0636845
18	ALERT UNIT, OIL	-----	-----	1	34150-ZH7-003	5858444

CRANKCASE COVER (1)

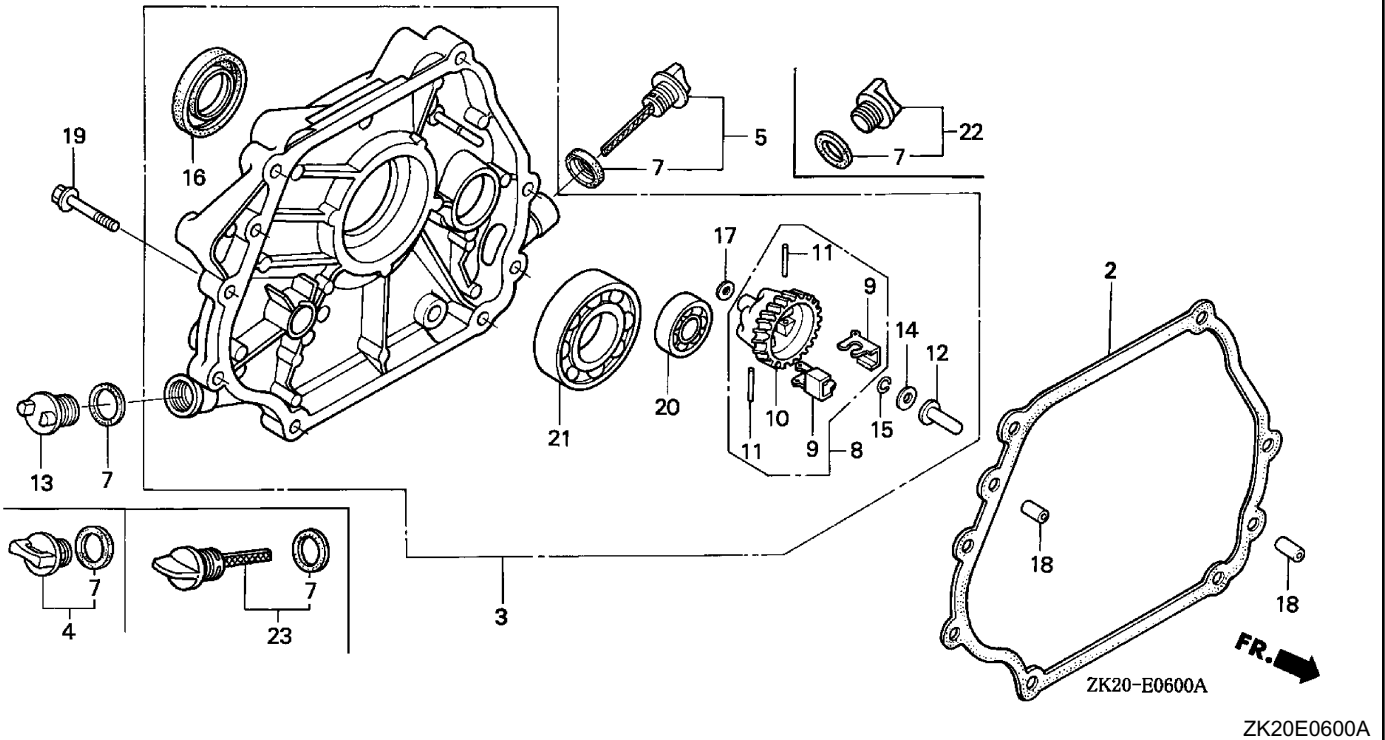

MODEL
A =GX240K1

TYPE
a =QA2

E-6

Ref	Description	Engine Serial Number		QTY	Part Number	H/C
		From	To			
2	GASKET, CASE COVER	-----	-----	1	11381-ZE2-801	6436851
3	COVER ASSY., CRANKCASE	-----	-----	1	11400-ZE2-603	7185572
4	CAP ASSY., OIL FILLER	-----	-----	1	15600-ZG4-003	4497921
5	CAP ASSY., OIL FILLER	-----	-----	1	15600-735-003	4523106
7	GASKET, OIL FILLER CAP	-----	-----	2	15625-ZE1-003	4497947
8	GOVERNOR ASSY. (BALANCER)	-----	-----	1	16510-ZE2-811	3690005
9	WEIGHT, GOVERNOR	-----	-----	2	16511-ZE2-000	2025955
10	HOLDER, GOVERNOR WEIGHT	-----	-----	1	16512-ZE2-811	3682010
11	PIN, GOVERNOR WEIGHT	-----	-----	2	16513-ZE2-000	2025971
12	SLIDER, GOVERNOR	-----	-----	1	16531-Z0A-000	6605117
15	CLIP, GOVERNOR HOLDER.....	-----	-----	1	90602-ZE1-000	2456697
		-----	-----	(1)	90602-ZE1-000	2456697
	CLIP, GOVERNOR HOLDER.....	-----	-----	(1)	90602-896-000	0928101
16	OIL SEAL (30X46X8)	-----	-----	1	91201-890-003	0756494
17	WASHER, PLAIN (6MM)	-----	-----	1	94101-06800	0345900
18	PIN, DOWEL (8X12).....	-----	-----	2	90701-HC4-000	2978443
19	BOLT, FLANGE (8X35)	-----	-----	7	95701-08035-00	2724029
20	BEARING, RADIAL BALL (6202)	-----	-----	1	96100-62020-00	0708941

CRANKCASE COVER (1)

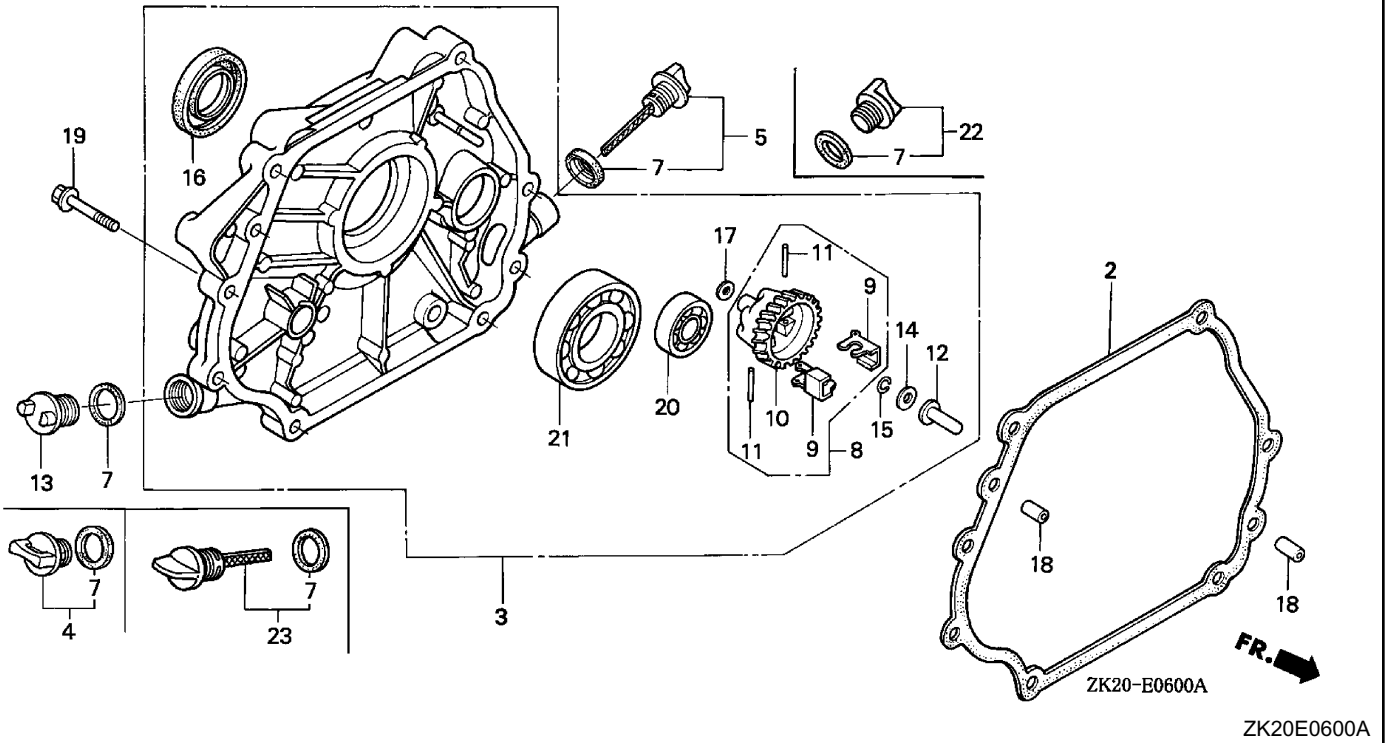

MODEL
A =GX240K1

TYPE
a =QA2

E-6

Ref	Description	Engine Serial Number		QTY	Part Number	H/C
		From	To			
21	BEARING, RADIAL BALL (6206)	-----	-----	1	96100-62060-00	0636118

CRANKSHAFT

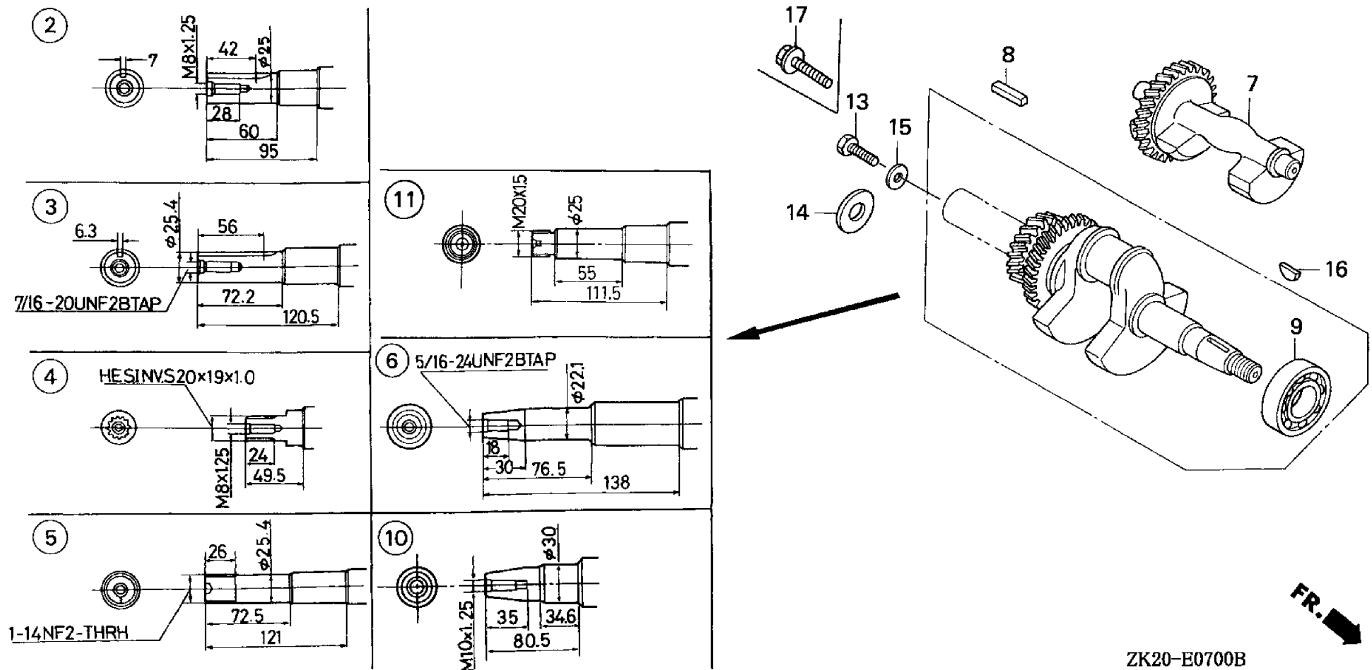

ZK20-E0700B

ZK20E0700B

MODEL **TYPE**
 A =GX240K1 a =QA2

E-7

Ref	Description	Engine Serial Number		QTY	Part Number	H/C
		From	To			
3	CRANKSHAFT (Q-TYPE).....	-----	-----	1	13320-ZE2-601	3735180
7	WEIGHT, BALANCER	-----	-----	1	13351-ZE2-010	3689817
8	KEY (6.3X6.3X43)	-----	-----	1	90745-ZE2-600	2027167
9	BEARING, RADIAL BALL (6206)	-----	-----	1	96100-62060-00	0636118
16	KEY, SPECIAL WOODRUFF (25X18)	-----	-----	1	90741-ZE2-000	2027159

PISTON

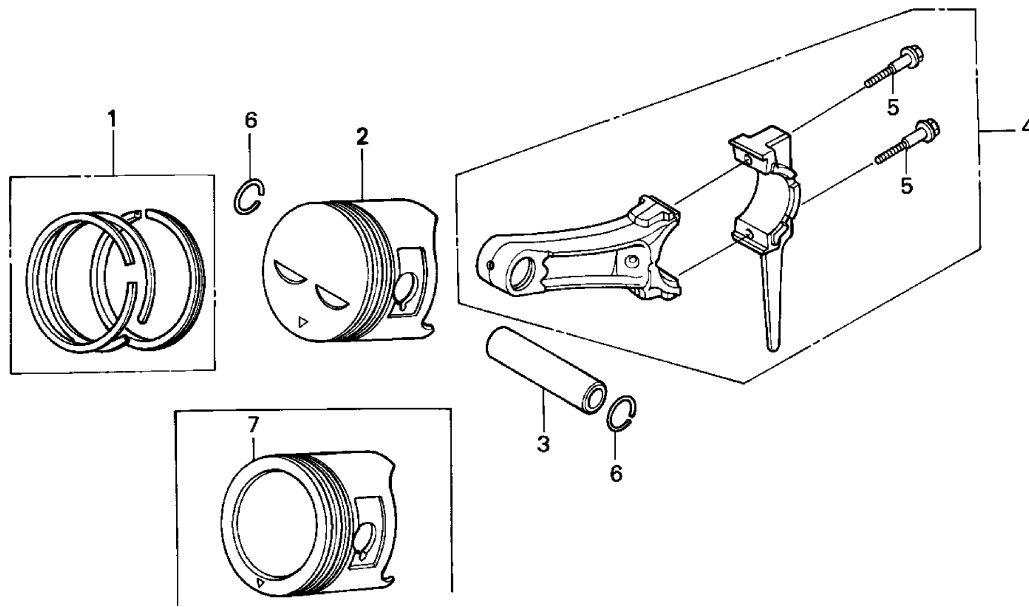

ZK20-E0800A



ZK20E0800A

MODEL
A =GX240K1

TYPE
a =QA2

E-8

Ref	Description	Engine Serial Number		QTY	Part Number	H/C
		From	To			
1	RING SET, PISTON (STD) (TEIKOKU)	-----	-----	1	13010-ZE2-921	6604573
	RING SET, PISTON (STD) (NIPPON)	-----	-----	1	13010-ZE2-922	6604581
	RING SET, PISTON (OS 0.25) (TEIKOKU)	-----	-----	(1)	13011-ZE2-921	6604607
	RING SET, PISTON (OS 0.25) (NIPPON) ..	-----	-----	(1)	13011-ZE2-922	6604615
	RING SET, PISTON (OS 0.50) (TEIKOKU)	-----	-----	(1)	13012-ZE2-921	6604623
	RING SET, PISTON (OS 0.50) (NIPPON) ..	-----	-----	(1)	13012-ZE2-922	6604631
	RING SET, PISTON (0.75) (TEIKOKU)	-----	-----	(1)	13013-ZE2-921	6604649
	RING SET, PISTON (0.75) (NIPPON)	-----	-----	(1)	13013-ZE2-922	6604656
2	PISTON (STD)	-----	-----	1	13101-ZE2-W00	3678547
	PISTON (OS 0.25)	-----	-----	(1)	13102-ZE2-W00	3678554
	PISTON (OS 0.50)	-----	-----	(1)	13103-ZE2-W00	3678562
	PISTON (0.75)	-----	-----	(1)	13104-ZE2-W00	3678570
3	PIN, PISTON	-----	-----	1	13111-ZE2-000	2025484
4	ROD ASSY., CONNECTING (STD)	-----	-----	1	13200-ZE2-010	6835250
	ROD ASSY., CONNECTING (US 0.25)	-----	-----	(1)	13200-ZE2-305	2110153
5	BOLT, CONNECTING ROD	-----	-----	2	90001-ZE8-000	2160489
6	CLIP, PISTON PIN (18MM)	-----	-----	2	90551-ZE1-000	2539120

CAMSHAFT

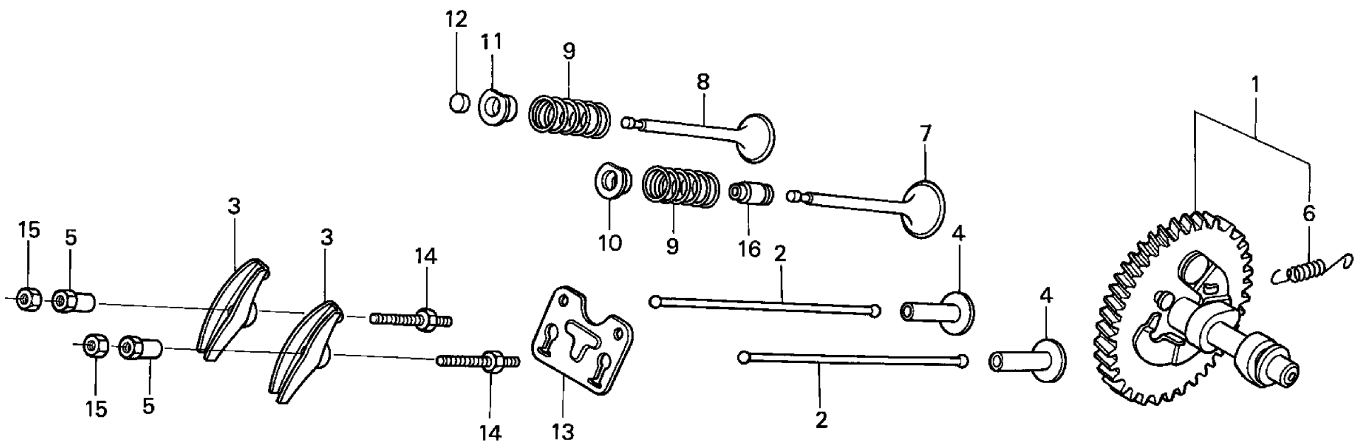

ZK20-E0900A



ZK20E0900A

MODEL
A =GX240K1

TYPE
a =QA2

E-9

Ref	Description	Engine Serial Number		QTY	Part Number	H/C
		From	To			
1	CAMSHAFT ASSY.	-----	-----	1	14100-ZE2-W01	5776927
2	ROD, PUSH	-----	-----	2	14410-ZE2-013	3337169
3	ARM, VALVE ROCKER	-----	-----	2	14431-ZE2-010	6206254
4	LIFTER, VALVE	-----	-----	2	14441-ZE2-000	2025609
5	PIVOT, ROCKER ARM.....	-----	-----	2	14451-ZE1-013	4300901
6	SPRING, WEIGHT RETURN	-----	-----	1	14568-ZE1-000	1426907
7	VALVE, IN.	-----	-----	1	14711-ZE2-000	2025617
8	VALVE, EX.	-----	-----	1	14721-ZE2-000	2025625
9	SPRING, VALVE	-----	-----	2	14751-ZE2-003	2025633
10	RETAINER, IN. VALVE SPRING	-----	-----	1	14771-ZE2-000	2025641
11	RETAINER, EX. VALVE SPRING	-----	-----	1	14773-ZE2-000	2025658
12	ROTATOR, VALVE.....	-----	-----	1	14781-ZE2-000	2025666
13	PLATE, PUSH ROD GUIDE.....	-----	-----	1	14791-ZE2-010	3707494
14	BOLT, PIVOT (8MM)	-----	-----	2	90012-ZE0-010	1756964
15	NUT, PIVOT ADJ.....	-----	-----	2	90206-ZE1-000	1431287
16	SEAL, VALVE STEM	-----	-----	1	12209-ZE8-003	2089571

RECOIL STARTER (1)

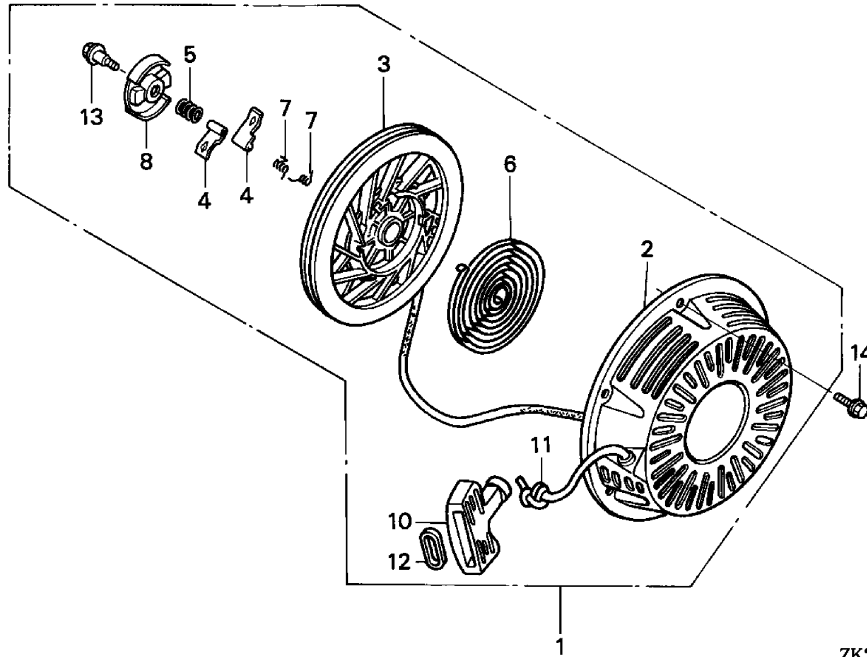

ZK20-B1100A



ZK20E1100A

MODEL
A =GX240K1

TYPE
a =QA2

E-11

Ref	Description	Engine Serial Number		QTY	Part Number	H/C
		From	To			
1	STARTER ASSY., RECOIL *R8* (BRIGHT RED).....	-----	4465232	1	28400-ZE2-W01ZA	3678844
	STARTER ASSY., RECOIL *NH1* (BLACK)	-----	-----	1	28400-ZE2-W01ZB	4220315
	STARTER ASSY., RECOIL *R280* (POWER RED).....	-----	-----	1	28400-ZE2-W01ZN	7324064
2	CASE, RECOIL STARTER *R8* (BRIGHT RED).....	-----	-----	1	28410-ZE2-W01ZA	3678851
	CASE, RECOIL STARTER *NH1* (BLACK) (BLACK).....	-----	-----	1	28410-ZE2-W01ZB	4220323
	CASE, RECOIL STARTER *R280* (POWER RED).....	-----	-----	1	28410-ZE2-W01ZN	7324072
3	PULLEY, RECOIL STARTER.....	-----	-----	1	28421-ZE2-W01	3678869
4	RATCHET, STARTER	-----	-----	2	28422-ZE2-W01	3678877
5	SPRING, FRICTION.....	-----	-----	1	28441-ZE2-W01	3678885
6	SPRING, STARTER RETURN	-----	-----	1	28442-ZE2-W01	3678893
7	SPRING, RATCHET.....	-----	-----	2	28443-ZE2-W01	3678901
8	RETAINER, SPRING	-----	-----	1	28444-ZE2-W01	3678919
10	GRIP, STARTER	-----	-----	1	28461-ZE2-W02	6133649
11	ROPE, RECOIL STARTER (#5X55").....	-----	-----	1	28462-ZE2-W11	6139729

RECOIL STARTER (1)

MODEL **TYPE**
 A =GX240K1 a =QA2

E-11

Ref	Description	Engine Serial Number		QTY	Part Number	H/C
		From	To			
13	SCREW, CENTER	-----	-----	1	90004-ZE2-W01	3679024
14	BOLT, FLANGE (6X10)	-----	-----	3	90008-ZE2-003	6437289

FAN COVER (1)

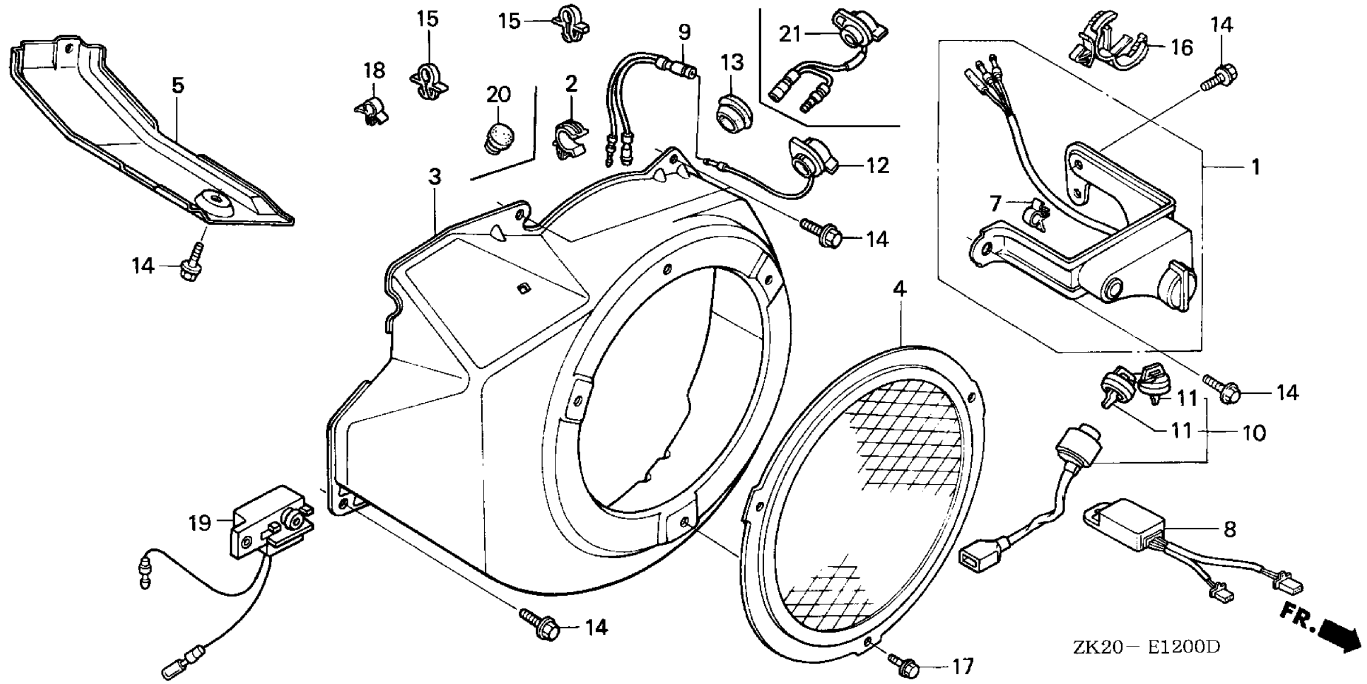

ZK20-E1200D

ZK20E1200D

MODEL
A =GX240K1

TYPE
a =QA2

E-12

Ref	Description	Engine Serial Number		QTY	Part Number	H/C
		From	To			
2	CLIP, TUBE	-----	-----	1	16731-ZE2-003	2026094
3	COVER, FAN *NH1* (BLACK)	-----	-----	1	19610-ZE2-010ZC	4330999
	COVER, FAN *R280* (POWER RED)	-----	-----	1	19610-ZE2-010ZL	7323561
5	SHROUD	-----	-----	1	19631-ZE2-D00	4024949
12	SWITCH ASSY., ENGINE STOP	-----	-----	1	36100-ZH7-003	5266184
14	BOLT, FLANGE (6X12) (CT200)	-----	-----	AR	90013-883-000	0636845
16	CLIP, WIRE HARNESS	-----	-----	1	90684-ZA0-601	2539138

CARBURETOR (4)

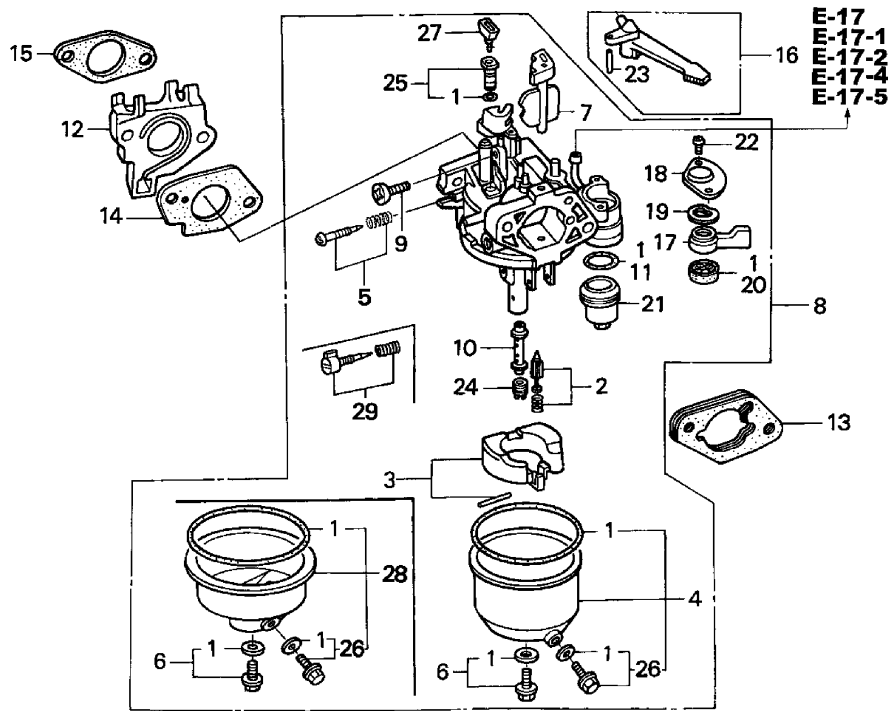

ZK20-E1403D



ZK20E1403D

MODEL
A =GX240K1

TYPE
a =QA2

E-14-3

Ref	Description	Engine Serial Number		QTY	Part Number	H/C
		From	To			
1	GASKET SET	-----	-----	1	16010-ZE2-812	3511383
2	VALVE SET, FLOAT.....	-----	-----	1	16011-ZA0-931	2059236
3	FLOAT SET	-----	-----	1	16013-ZA0-931	2059244
6	SCREW SET B.....	-----	-----	1	16028-ZE0-005	1441518
7	CHOKE SET	-----	-----	1	16044-ZE2-005	2090017
8	CARBURETOR ASSY. (BE70B B).....	-----	-----	1	16100-ZE2-W71	5222211
9	SCREW, THROTTLE STOP.....	-----	-----	1	16124-ZE0-005	1441559
10	NOZZLE, MAIN (CARBURETOR NO.).....	-----	-----	1	16166-ZE2-W70	4330908
11	GASKET, FUEL STRAINER CUP	-----	-----	1	16173-001-004	0005652
12	INSULATOR, CARBURETOR	-----	-----	1	16211-ZE2-000	2025906
13	SPACER, CARBURETOR	-----	-----	1	16220-ZA0-702	2686533
14	GASKET, CARBURETOR	-----	-----	1	16221-ZA0-800	3678620
15	GASKET, INSULATOR.....	-----	-----	1	16223-ZA0-800	3678638
16	LEVER, CHOKE (STD).....	-----	-----	1	16610-ZE1-000	1440114
17	LEVER, VALVE (CARBURETOR NO.).....	-----	-----	1	16953-ZE1-812	5140876
18	PLATE, LEVER SETTING (CARBURETOR NO.).....	-----	-----	1	16954-ZE1-812	5148135

CARBURETOR (4)

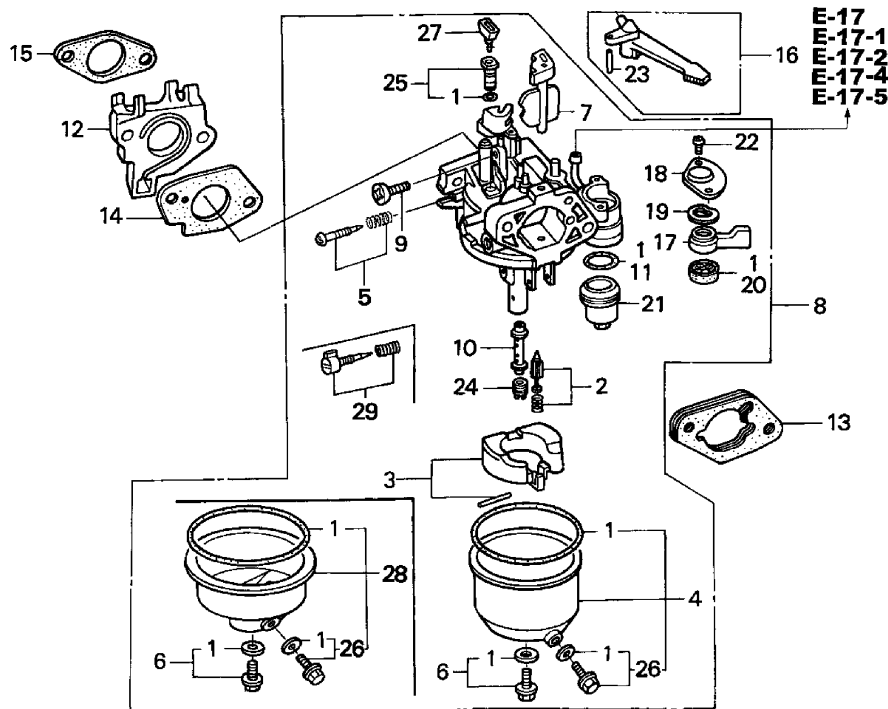

ZK20-E1403D



ZK20E1403D

MODEL
A =GX240K1

TYPE
a =QA2

E-14-3

Ref	Description	Engine Serial Number		QTY	Part Number	H/C
		From	To			
19	SPRING, VALVE LEVER	-----	-----	1	16956-ZE1-811	1807809
20	GASKET, VALVE	-----	-----	1	16957-ZE1-812	3440708
21	CUP, FUEL STRAINER	-----	-----	1	16967-ZE0-811	1441583
22	SCREW, PAN (3X6).....	-----	-----	2	93500-03006-0H	0561654
23	PIN, SPRING (2X12)	-----	-----	1	94305-20122	1441591
24	JET, MAIN (#82) (CARBURETOR NO.).....	-----	-----	(1)	99101-ZH8-0820	5947130
	JET, MAIN (#85) (CARBURETOR NO.).....	-----	-----	(1)	99101-ZH8-0850	5947148
	JET, MAIN (#88) (CARBURETOR NO.).....	-----	-----	1	99101-ZH8-0880	5945555
25	JET SET, PILOT (#40) (CARBURETOR NO.).....	-----	-----	1	99204-ZE2-0400	3683141
26	SCREW SET, DRAIN (CARBURETOR NO.).....	-----	-----	1	16024-ZE1-811	1672187
27	COLLAR, SET (CARBURETOR NO.).....	-----	-----	1	16172-ZE3-W10	3738358
28	CHAMBER SET, FLOAT (CARBURETOR NO.).....	-----	-----	1	16015-ZE8-005	2089993

CARBURETOR (4)

MODEL **TYPE**
 A =GX240K1 a =QA2

E-14-3

Ref	Description	Engine Serial Number		QTY	Part Number	H/C
		From	To			
29	SCREW SET (CARBURETOR NO.).....	-----		1	16016-ZH7-W01	4219879

AIR CLEANER (3)

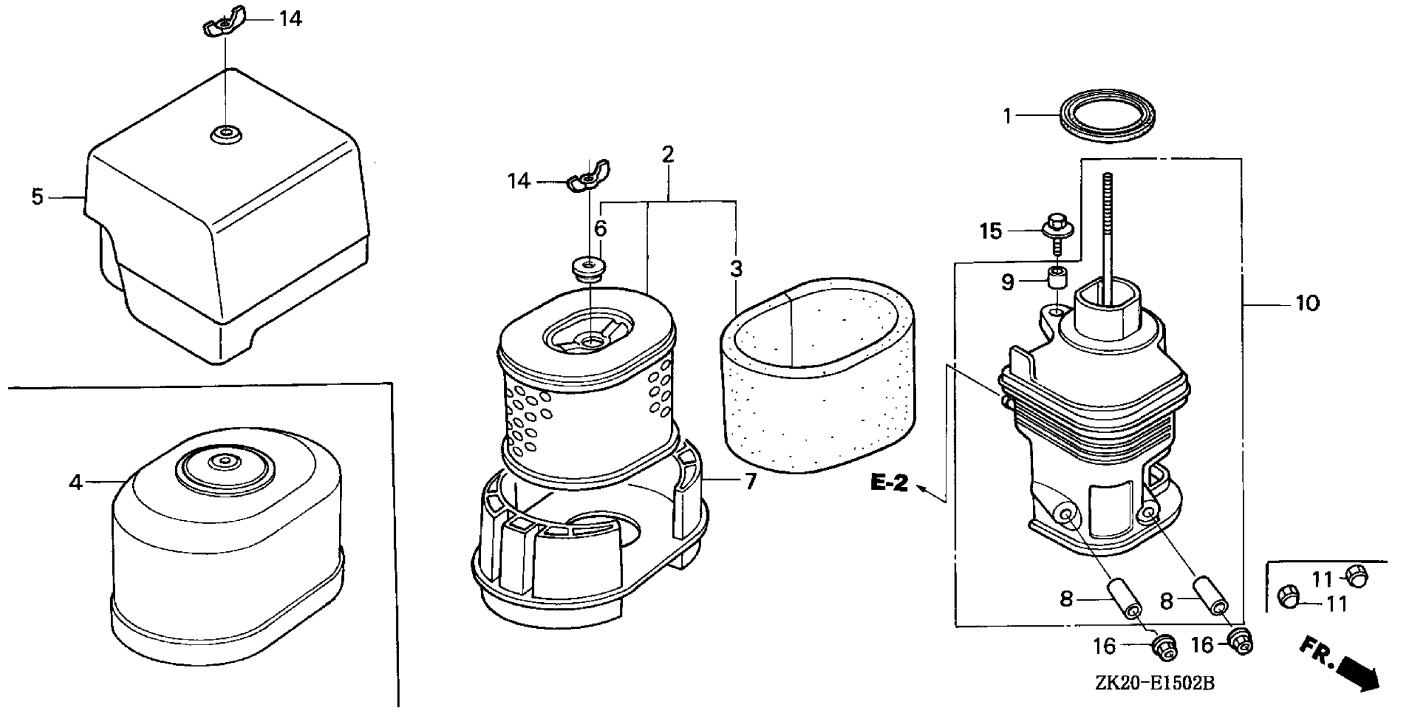

ZK20E1502B

MODEL
A =GX240K1

TYPE
a =QA2

E-15-2

Ref	Description	Engine Serial Number		QTY	Part Number	H/C
		From	To			
1	GASKET, ELBOW	-----	-----	1	16271-ZE2-010	7301195
2	ELEMENT, AIR CLEANER (DUAL)	-----	-----	1	17210-ZE2-505	5266721
	ELEMENT, AIR CLEANER (DUAL)	-----	-----	1	17210-ZE2-515	7460967
3	FILTER (OUTER)	-----	-----	1	17218-ZE2-505	5196308
5	COVER, AIR CLEANER.....	-----	-----	1	17231-ZH9-820	3690054
6	GROMMET, AIR CLEANER.....	-----	-----	1	17232-891-000	0999763
8	COLLAR, AIR CLEANER	-----	-----	2	17238-ZE2-310	2384105
9	COLLAR B, AIR CLEANER	-----	-----	1	17239-ZE1-000	1427533
10	ELBOW, AIR CLEANER.....	-----	-----	1	17410-ZE2-020	2414290
14	WINGNUT, TOOL BOX SETTING	-----	-----	2	90325-044-000	0127720
15	BOLT-WASHER (6X22)	-----	-----	1	90009-ZE2-003	6437297
16	NUT, FLANGE (6MM).....	-----	-----	2	94050-06000	0471623

MUFFLER (2)

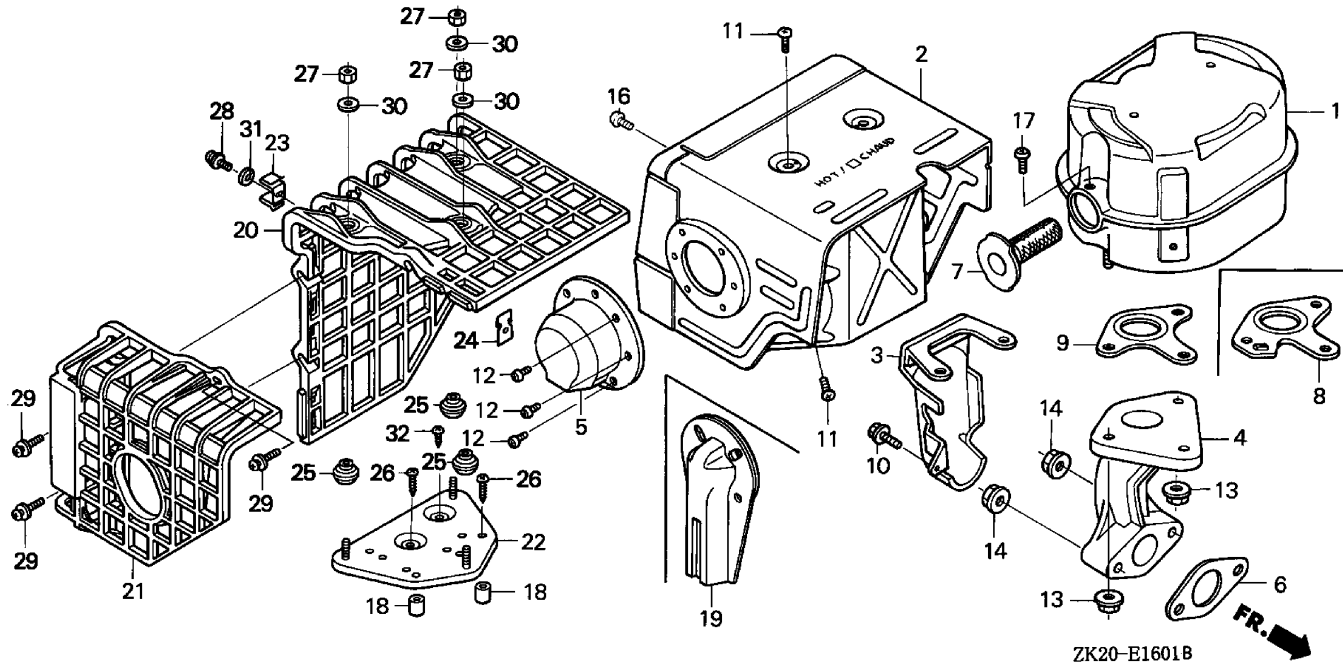

ZK20E1601B

MODEL
A =GX240K1

TYPE
a =QA2

E-16-1

Ref	Description	Engine Serial Number		QTY	Part Number	H/C
		From	To			
1	MUFFLER.....	-----	-----	1	18310-ZE2-W00	3678745
2	PROTECTOR, MUFFLER	-----	-----	1	18320-ZE2-W01	4613642
3	PROTECTOR, EX. PIPE	-----	-----	1	18323-ZE2-W00	3678786
4	PIPE, EX.	-----	-----	1	18330-ZE2-W00	3678794
5	CAP, MUFFLER	-----	-----	1	18331-ZE2-810	2026227
6	GASKET, EX. PIPE	-----	-----	1	18333-ZE3-800	3520194
	GASKET, EX. PIPE (WACKER).....	-----	-----	1	18333-ZK6-Y00	5164199
7	ARRESTER, SPARK	-----	-----	1	18355-ZE2-010	2482594
8	GASKET, MUFFLER (ARRESTER).....	-----	-----	1	18381-ZE2-W10	3678802
10	BOLT, FLANGE (6X12) (CT200)	-----	-----	1	90013-883-000	0636845
11	SCREW, TAPPING (5X8).....	-----	-----	4	90050-ZE1-000	1431105
12	SCREW, TAPPING (4X6).....	-----	-----	3	90055-ZE1-000	1431121
13	NUT, FLANGE (8MM).....	-----	-----	3	94050-08000	0481143
14	NUT, FLANGE (8MM).....	-----	-----	2	94050-08000	0481143
16	SCREW, TAPPING (5X8).....	-----	-----	2	90050-ZE1-000	1431105
17	SCREW, TAPPING (5X8).....	-----	-----	1	90050-ZE1-000	1431105

FUEL TANK (3)

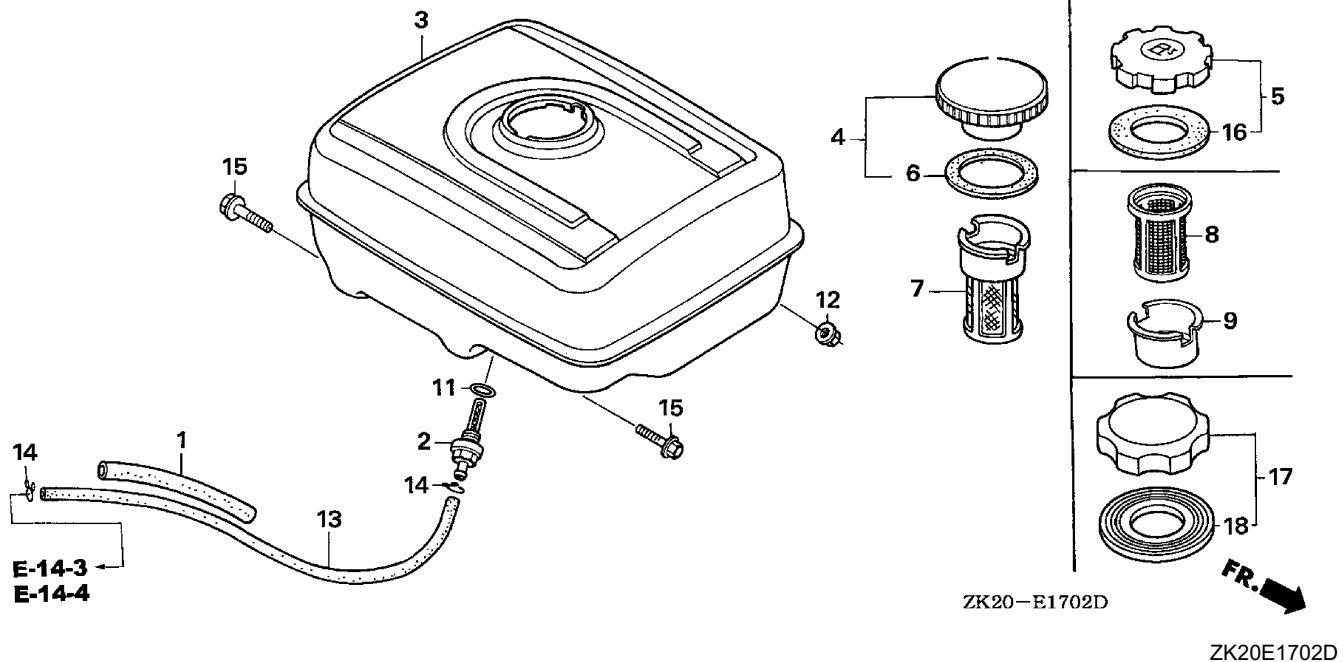

MODEL TYPE
A =GX240K1 a =QA2

E-17-2

Ref	Description	Engine Serial Number		QTY	Part Number	H/C
		From	To			
1	RUBBER, SUPPORTER (107MM)			1	16854-ZH8-000	3683646
2	JOINT, FUEL TANK			1	16955-ZE1-000	1427459
3	TANK, FUEL *NH31* (MCKINLEY WHITE)		4568628	1	17510-ZE2-010ZA	3690070
	TANK, FUEL *NH31* (MCKINLEY WHITE)		4776725	1	17510-ZE2-020ZA	7627540
	TANK, FUEL *NH1* (BLACK)		4776725	1	17510-ZE2-020ZD	7640766
	TANK, FUEL *NH1* (BLACK)			1	17510-ZE2-800ZA	8157166
	TANK, FUEL *NH31* (MCKINLEY WHITE)			1	17510-ZE2-800ZC	8157174
5	CAP, FUEL FILLER		4495553	1	17620-ZH7-023	5344817
7	FILTER, FUEL			1	17672-ZE2-W01	4270864
11	O-RING (13.5X1.5) (ARAI)			1	91353-671-003	0949883
12	NUT, FLANGE (8MM)			2	94050-08000	0481143
13	BULK HOSE, FUEL (4.5X3000) (4.5X222)			1	95001-45003-60M	5137104
14	CLIP, TUBE (B8)			2	95002-02080	0250647
15	BOLT, FLANGE (8X25)			2	95701-08025-00	2545325
16	GASKET, FUEL FILLER CAP		4495553	1	17631-ZH7-003	4608725
	GASKET, FUEL FILLER CAP		4495553	1	17631-329-003	2820587
17	CAP, FUEL FILLER	4495554		1	17620-ZOT-305	7736788
18	GASKET, FUEL FILLER CAP	4495554		1	17631-ZOT-812	7444441

FLYWHEEL

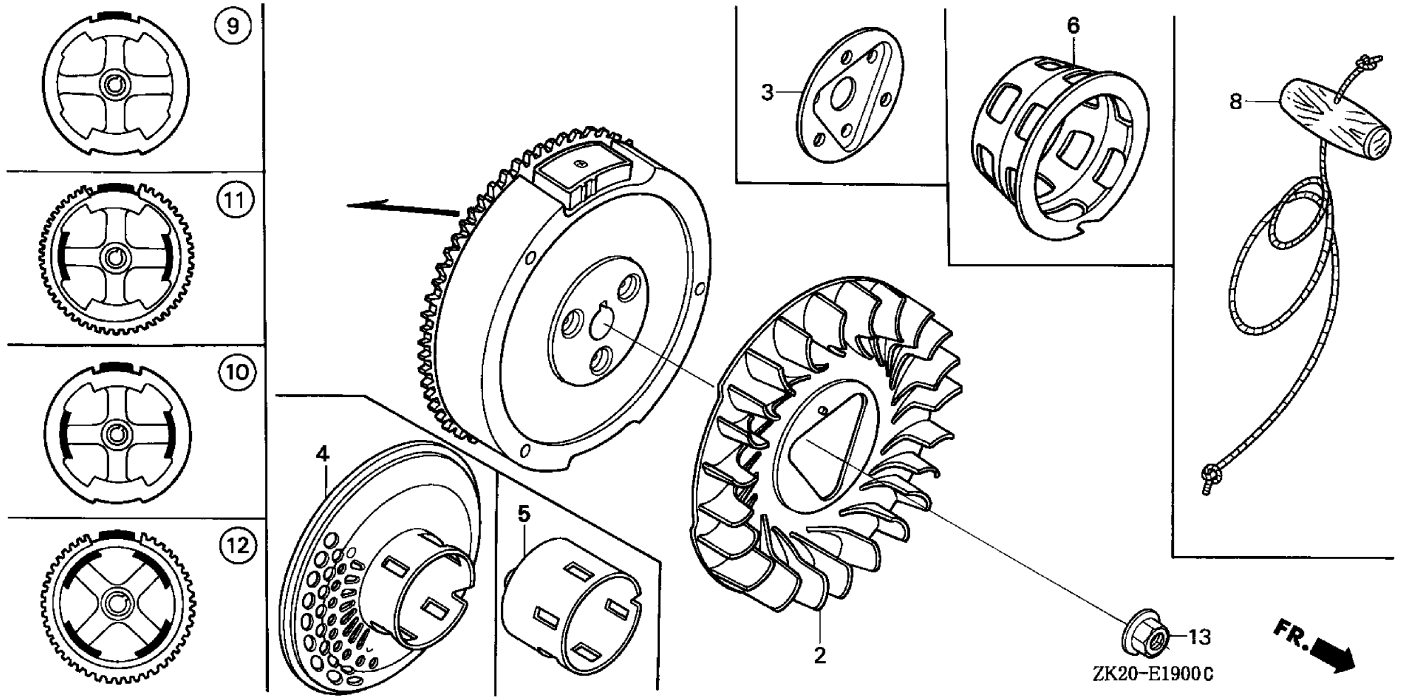

ZK20E1900C

MODEL
A =GX240K1

TYPE
a =QA2

E-19

Ref	Description	Engine Serial Number		QTY	Part Number	H/C
		From	To			
2	FAN, COOLING	-----	-----	1	19511-ZE2-000	2026250
4	PULLEY, STARTER (SCREEN GRID).....	-----	-----	1	28450-ZE2-W11	3678935
9	FLYWHEEL	-----	-----	1	31100-ZE2-010	5339486
13	NUT, SPECIAL (16MM) (1)	-----	-----	1	90201-ZE3-V00	5032727

IGNITION COIL

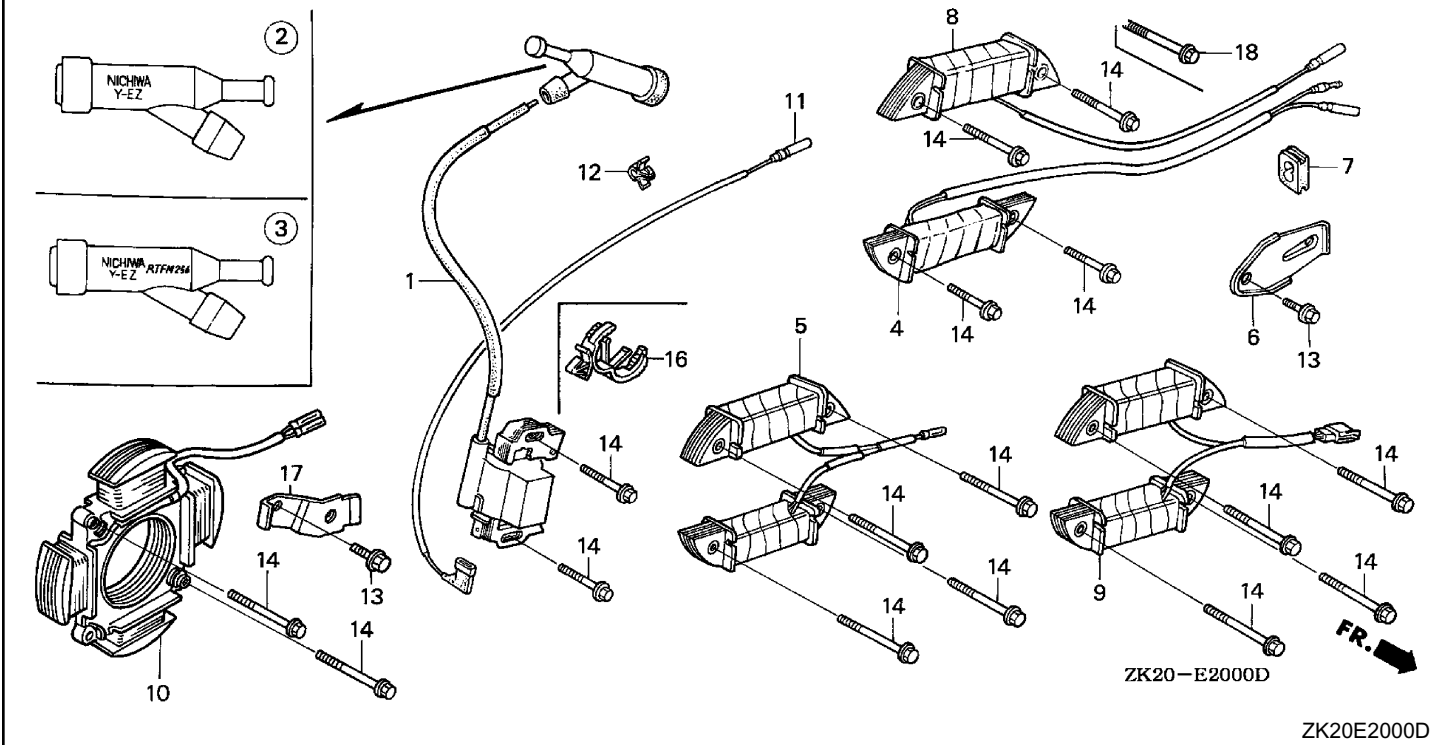

MODEL
A =GX240K1

TYPE
a =QA2

E-20

Ref	Description	Engine Serial Number		QTY	Part Number	H/C
		From	To			
1	COIL ASSY., IGNITION	-----	-----	1	30500-ZF6-W02	7032428
3	CAP ASSY., NOISE SUPPRESSOR (NICHIBA Y-EZ RTFM256)	-----	-----	1	30700-ZE1-013	3526837
7	GROMMET, WIRE	-----	-----	1	31512-ZE2-000	2026557
11	WIRE, STOP SWITCH (370MM)	-----	-----	1	36101-ZE1-010	3684032
14	BOLT, FLANGE (6X28)	-----	-----	AR	90015-883-000	0636852

CONTROL

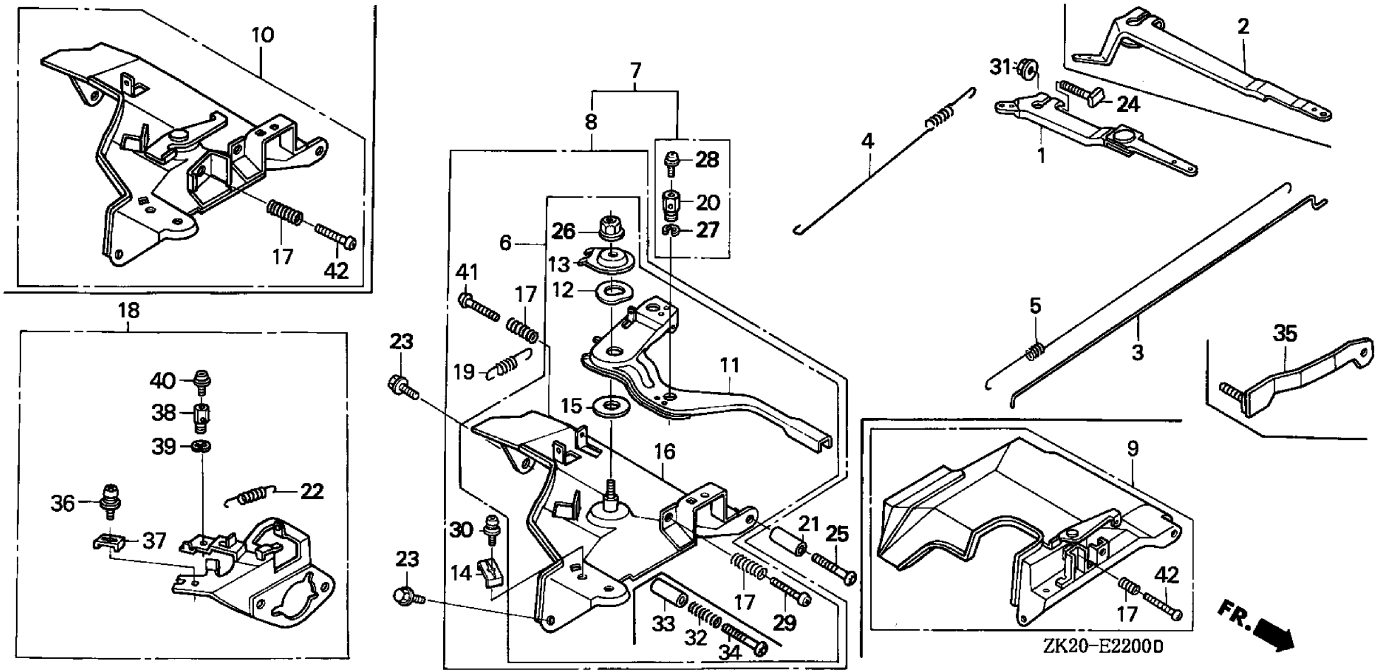

ZK20E2200D

MODEL
A =GX240K1

TYPE
a =QA2

E-22

Ref	Description	Engine Serial Number		QTY	Part Number	H/C
		From	To			
2	ARM, GOVERNOR.....			1	16551-ZE2-000	2026003
3	ROD, GOVERNOR.....			1	16555-ZE2-000	2026011
4	SPRING, GOVERNOR.....			1	16561-ZE2-000	2026029
5	SPRING, THROTTLE RETURN.....			1	16562-ZE2-000	2026037
8	CONTROL ASSY. (REMOTE)			1	16570-ZE2-W20	3678653
11	LEVER, CONTROL			1	16571-ZE2-W00	3678661
12	SPRING, LEVER			1	16574-ZE1-000	1427384
13	WASHER, CONTROL LEVER			1	16575-ZE2-W00	3678679
14	HOLDER, CABLE.....			1	16576-891-000	0800466
15	SPACER, CONTROL LEVER.....			1	16578-ZE1-000	1427400
16	BASE, CONTROL.....			1	16581-ZE2-W00	3678687
17	SPRING, CONTROL ADJUSTING.....			1	16584-883-300	0636431
19	SPRING, CABLE RETURN			1	16592-883-310	0743203
23	BOLT, FLANGE (6X12) (CT200)			2	90013-883-000	0636845
24	BOLT, GOVERNOR ARM			1	90015-ZE5-010	2418671
26	NUT, SELF-LOCK (6MM).....			1	90114-SAO-000	1410182
29	SCREW, PAN (5X28).....			1	93500-05028-0A	0171819
30	SCREW, PAN (5X16).....			1	93500-05016-0A	0145557

CONTROL

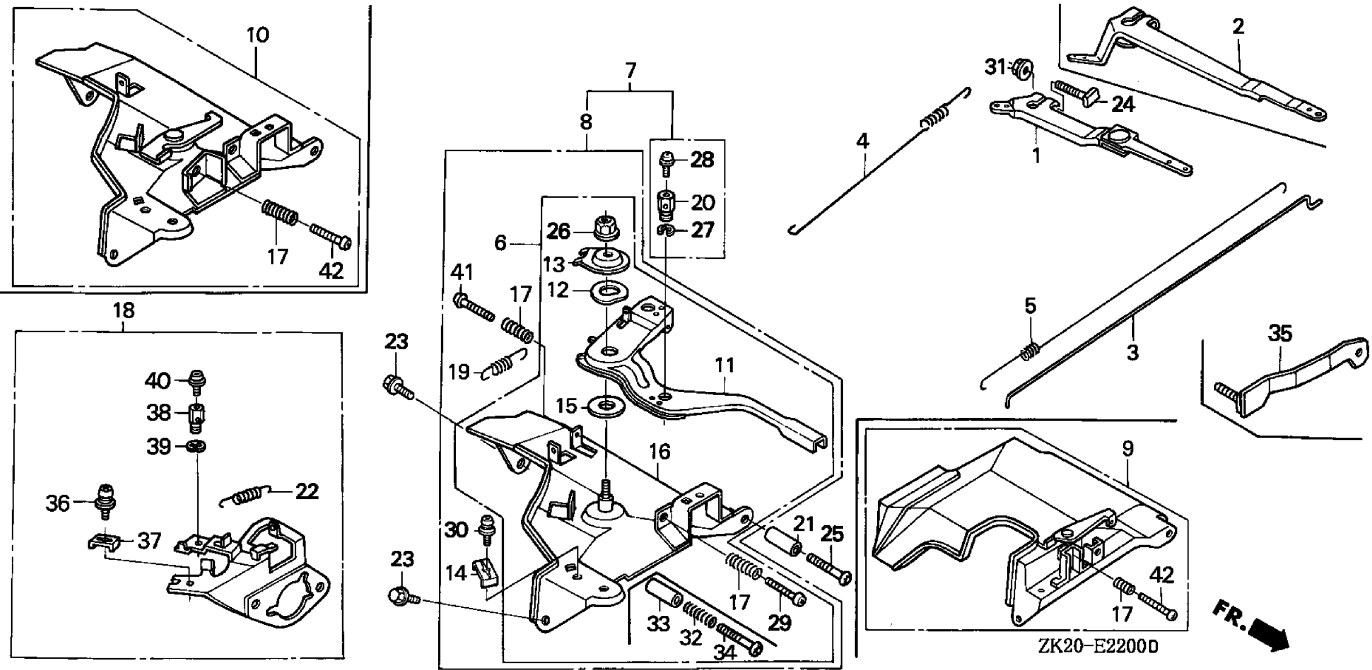

ZK20E2200D

MODEL
A =GX240K1

TYPE
a =QA2

E-22

Ref	Description	Engine Serial Number		QTY	Part Number	H/C
		From	To			
31	NUT, FLANGE (6MM).....	-----	-----	1	94050-06000	0471623

LABEL

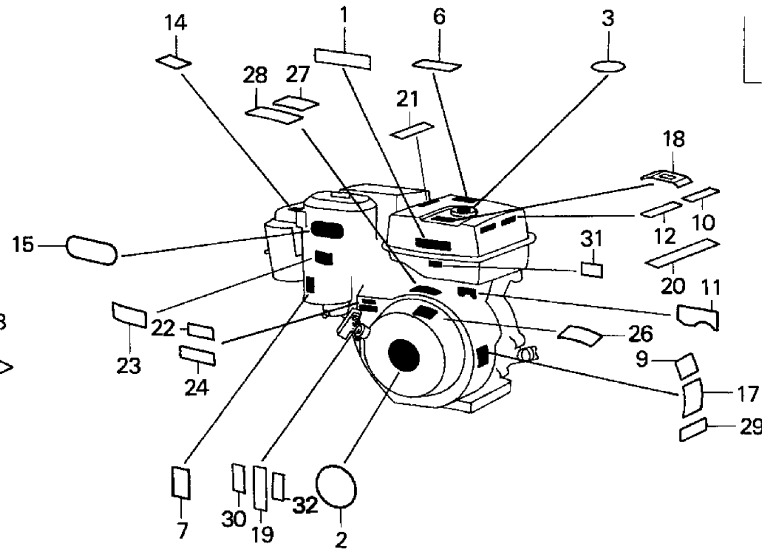
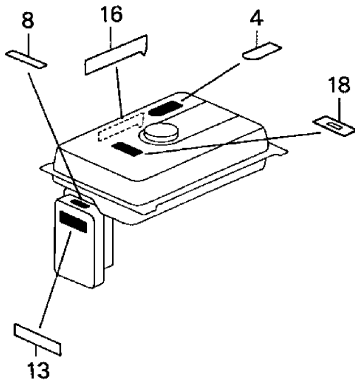
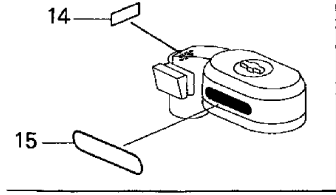

ZK20-E2800E

ZK20E2800E

MODEL
A =GX240K1

TYPE
a =QA2

E-28

Ref	Description	Engine Serial Number		QTY	Part Number	H/C
		From	To			
1	LABEL, CAUTION	-----	-----	1	87522-ZH9-010	7005820
2	EMBLEM.....	-----	4465232	1	87521-ZE2-W02	6955710
	EMBLEM.....	4465233	-----	1	87521-ZE2-W03	7658537
7	MARK, CHOKE (EXTERNAL)	-----	-----	1	87528-ZE2-810	2026979
12	MARK, OIL ALERT (E)	-----	-----	1	87532-ZH8-810	4193355

TOOLS (1)

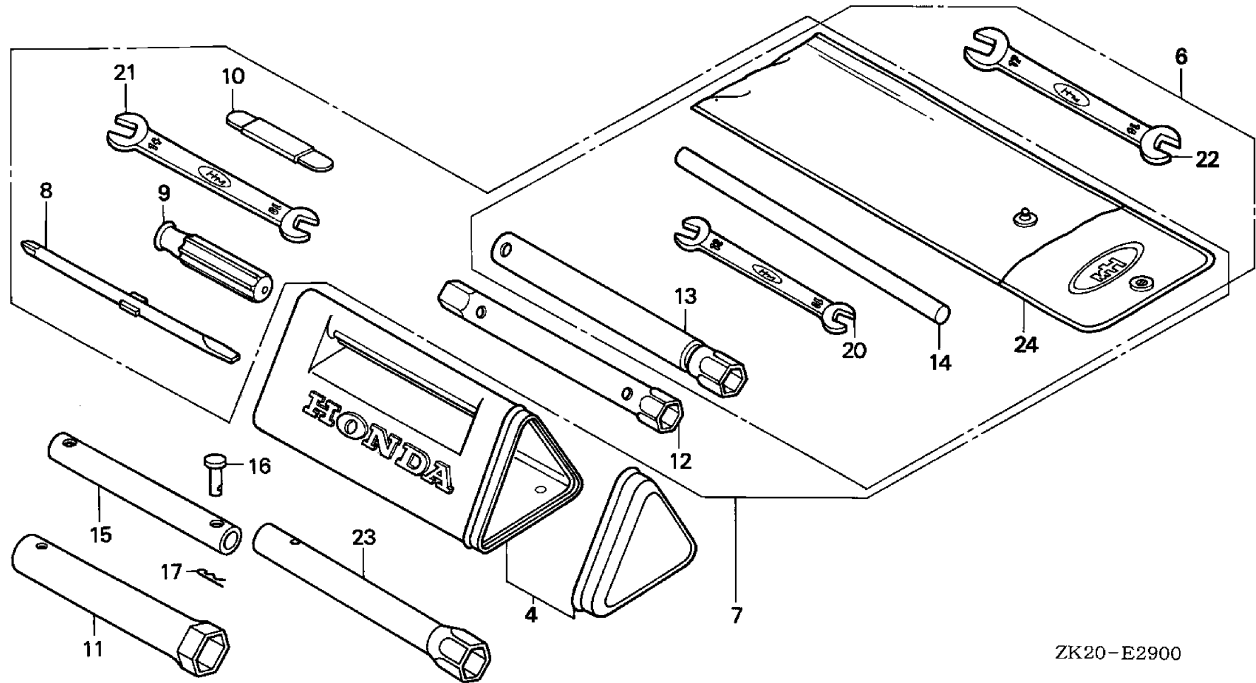

ZK20-E2900

ZK20E2900

MODEL
A =GX240K1

TYPE
a =QA2

E-29

Ref	Description	Engine Serial Number		QTY	Part Number	H/C
		From	To			
13	WRENCH, SPARK PLUG.....	-----	-----	(1)	89218-ZE1-000	1431048

Part Number Index

PART NUMBER INDEX

Part Number	Grid	Page	Part Number	Grid	Page	Part Number	Grid	Page
(1)			16044-ZE2-005	1-C6	1-13	17631-ZH7-003	1-D1	1-18
11381-ZE2-801	1-C2	1-5	16100-ZE2-W71	1-C6	1-13	17672-ZE2-W01	1-D1	1-18
11400-ZE2-603	1-C2	1-5	16124-ZE0-005	1-C6	1-13	18310-ZE2-W00	1-C8	1-17
12000-ZE2-408	1-C2	1-4	16166-ZE2-W70	1-C6	1-13	18320-ZE2-W01	1-C8	1-17
12200-ZH9-405	1-C1	1-2	16172-ZE3-W10	1-C7	1-14	18323-ZE2-W00	1-C8	1-17
12204-ZE2-306	1-C1	1-2	16173-001-004	1-C6	1-13	18330-ZE2-W00	1-C8	1-17
12205-ZE2-305	1-C1	1-2	16211-ZE2-000	1-C6	1-13	18331-ZE2-810	1-C8	1-17
12209-ZE8-003	1-C4	1-9	16220-ZA0-702	1-C6	1-13	18333-ZE3-800	1-C8	1-17
12216-ZE2-300	1-C1	1-2	16221-ZA0-800	1-C6	1-13	18333-ZK6-Y00	1-C8	1-17
12251-ZE2-800	1-C1	1-2	16223-ZA0-800	1-C6	1-13	18355-ZE2-010	1-C8	1-17
12310-ZE2-020	1-C1	1-2	16271-ZE2-010	1-C8	1-16	18381-ZE2-W10	1-C8	1-17
12391-ZE2-020	1-C1	1-2	16510-ZE2-811	1-C2	1-5	19511-ZE2-000	1-D1	1-19
13010-ZE2-921	1-C4	1-8	16511-ZE2-000	1-C2	1-5	19610-ZE2-010ZC	1-C6	1-12
13010-ZE2-922	1-C4	1-8	16512-ZE2-811	1-C2	1-5	19610-ZE2-010ZL	1-C6	1-12
13011-ZE2-921	1-C4	1-8	16513-ZE2-000	1-C2	1-5	19631-ZE2-D00	1-C6	1-12
13011-ZE2-922	1-C4	1-8	16531-Z0A-000	1-C2	1-5			
13012-ZE2-921	1-C4	1-8	16541-ZE2-010	1-C2	1-4	(2)		
13012-ZE2-922	1-C4	1-8	16551-ZE2-000	1-D2	1-21	28400-ZE2-W01ZA	1-C5	1-10
13013-ZE2-921	1-C4	1-8	16555-ZE2-000	1-D2	1-21	28400-ZE2-W01ZB	1-C5	1-10
13013-ZE2-922	1-C4	1-8	16561-ZE2-000	1-D2	1-21	28400-ZE2-W01ZN	1-C5	1-10
13101-ZE2-W00	1-C4	1-8	16562-ZE2-000	1-D2	1-21	28410-ZE2-W01ZA	1-C5	1-10
13102-ZE2-W00	1-C4	1-8	16570-ZE2-W20	1-D2	1-21	28410-ZE2-W01ZB	1-C5	1-10
13103-ZE2-W00	1-C4	1-8	16571-ZE2-W00	1-D2	1-21	28410-ZE2-W01ZN	1-C5	1-10
13104-ZE2-W00	1-C4	1-8	16574-ZE1-000	1-D2	1-21	28421-ZE2-W01	1-C5	1-10
13111-ZE2-000	1-C4	1-8	16575-ZE2-W00	1-D2	1-21	28422-ZE2-W01	1-C5	1-10
13200-ZE2-010	1-C4	1-8	16576-891-000	1-D2	1-21	28441-ZE2-W01	1-C5	1-10
13200-ZE2-305	1-C4	1-8	16578-ZE1-000	1-D2	1-21	28442-ZE2-W01	1-C5	1-10
13320-ZE2-601	1-C3	1-7	16581-ZE2-W00	1-D2	1-21	28443-ZE2-W01	1-C5	1-10
13351-ZE2-010	1-C3	1-7	16584-883-300	1-D2	1-21	28444-ZE2-W01	1-C5	1-10
14100-ZE2-W01	1-C4	1-9	16592-883-310	1-D2	1-21	28450-ZE2-W11	1-D1	1-19
14410-ZE2-013	1-C4	1-9	16610-ZE1-000	1-C6	1-13	28461-ZE2-W02	1-C5	1-10
14431-ZE2-010	1-C4	1-9	16731-ZE2-003	1-C6	1-12	28462-ZE2-W11	1-C5	1-10
14441-ZE2-000	1-C4	1-9	16854-ZH8-000	1-D1	1-18			
14451-ZE1-013	1-C4	1-9	16953-ZE1-812	1-C6	1-13	(3)		
14568-ZE1-000	1-C4	1-9	16954-ZE1-812	1-C6	1-13	30500-ZF6-W02	1-D2	1-20
14711-ZE2-000	1-C4	1-9	16955-ZE1-000	1-D1	1-18	30700-ZE1-013	1-D2	1-20
14721-ZE2-000	1-C4	1-9	16956-ZE1-811	1-C7	1-14	31100-ZE2-010	1-D1	1-19
14751-ZE2-003	1-C4	1-9	16957-ZE1-812	1-C7	1-14	31512-ZE2-000	1-D2	1-20
14771-ZE2-000	1-C4	1-9	16967-ZE0-811	1-C7	1-14	34150-ZH7-003	1-C2	1-4
14773-ZE2-000	1-C4	1-9	17210-ZE2-505	1-C8	1-16	36100-ZH7-003	1-C6	1-12
14775-ZE2-010	1-C1	1-2	17210-ZE2-515	1-C8	1-16	36101-ZE1-010	1-D2	1-20
14781-ZE2-000	1-C4	1-9	17218-ZE2-505	1-C8	1-16			
14791-ZE2-010	1-C4	1-9	17231-ZH9-820	1-C8	1-16	(8)		
15510-ZE2-043	1-C2	1-4	17232-891-000	1-C8	1-16	87521-ZE2-W02	1-D3	1-23
15600-735-003	1-C2	1-5	17238-ZE2-310	1-C8	1-16	87521-ZE2-W03	1-D3	1-23
15600-ZG4-003	1-C2	1-5	17239-ZE1-000	1-C8	1-16	87522-ZH9-010	1-D3	1-23
15625-ZE1-003	1-C2	1-5	17410-ZE2-020	1-C8	1-16	87528-ZE2-810	1-D3	1-23
16010-ZE2-812	1-C6	1-13	17510-ZE2-010ZA	1-D1	1-18	87532-ZH8-810	1-D3	1-23
16011-ZA0-931	1-C6	1-13	17510-ZE2-020ZA	1-D1	1-18	89218-ZE1-000	1-D4	1-24
16013-ZA0-931	1-C6	1-13	17510-ZE2-020ZD	1-D1	1-18			
16015-ZE8-005	1-C7	1-14	17510-ZE2-800ZA	1-D1	1-18	(9)		
16016-ZH7-W01	1-C7	1-15	17510-ZE2-800ZC	1-D1	1-18	90001-ZE8-000	1-C4	1-8
16024-ZE1-811	1-C7	1-14	17620-Z0T-305	1-D1	1-18			
16028-ZE0-005	1-C6	1-13	17620-ZH7-023	1-D1	1-18			
			17631-329-003	1-D1	1-18			
			17631-Z0T-812	1-D1	1-18			

PART NUMBER INDEX

Part Number	Grid	Page	Part Number	Grid	Page	Part Number	Grid	Page
90004-ZE2-W01	1-C5	1-11	96100-62060-00	1-C3	1-7			
90008-ZE2-003	1-C5	1-11	98079-55846	1-C1	1-2			
90009-ZE2-003	1-C8	1-16	98079-55855	1-C1	1-2			
90012-ZE0-010	1-C4	1-9	98079-56846	1-C1	1-3			
90013-883-000	1-C2	1-4	98079-56855	1-C1	1-3			
	1-C6	1-12	99101-ZH8-0820	1-C7	1-14			
	1-C8	1-17	99101-ZH8-0850	1-C7	1-14			
	1-D2	1-21	99101-ZH8-0880	1-C7	1-14			
90014-ZE2-000	1-C1	1-2	99204-ZE2-0400	1-C7	1-14			
90015-883-000	1-D2	1-20						
90015-ZE5-010	1-D2	1-21						
90042-ZE2-000	1-C1	1-2						
90050-ZE1-000	1-C8	1-17						
90055-ZE1-000	1-C8	1-17						
90114-SA0-000	1-D2	1-21						
90131-896-650	1-C2	1-4						
90201-ZE3-V00	1-D1	1-19						
90206-ZE1-000	1-C4	1-9						
90325-044-000	1-C8	1-16						
90441-ZE2-010	1-C1	1-2						
90446-KE1-000	1-C2	1-4						
90551-ZE1-000	1-C4	1-8						
90602-896-000	1-C2	1-5						
90602-ZE1-000	1-C2	1-5						
90684-ZA0-601	1-C6	1-12						
90701-HC4-000	1-C2	1-5						
90741-ZE2-000	1-C3	1-7						
90745-ZE2-600	1-C3	1-7						
91201-890-003	1-C2	1-4						
	1-C2	1-5						
91353-671-003	1-C2	1-4						
	1-D1	1-18						
92900-08032-0E	1-C1	1-2						
93500-03006-0H	1-C7	1-14						
93500-05016-0A	1-D2	1-21						
93500-05028-0A	1-D2	1-21						
94050-06000	1-C8	1-16						
	1-D3	1-22						
94050-08000	1-C8	1-17						
	1-D1	1-18						
94050-10000	1-C2	1-4						
94101-06800	1-C2	1-5						
94109-12000	1-C2	1-4						
94251-10000	1-C2	1-4						
94301-12200	1-C1	1-2						
94305-20122	1-C7	1-14						
95001-45003-60M	1-D1	1-18						
95002-02080	1-D1	1-18						
95005-11001-30M	1-C1	1-2						
95701-06012-00	1-C2	1-4						
95701-08025-00	1-D1	1-18						
95701-08035-00	1-C2	1-5						
95701-10080-00	1-C1	1-2						
96100-62020-00	1-C2	1-4						
	1-C2	1-5						
96100-62060-00	1-C3	1-6						

For Discount Troy Bilt Parts Call 606-678-9623 or 606-561-4983

Description

Index

DESCRIPTION INDEX

Description	Grid	Page	Ref	Description	Grid	Page	Ref
(A)				CLIP, TUBE (B8)	1-D1	1-18	14
ALERT UNIT, OIL	1-C2	1-4	18	CLIP, VALVE GUIDE	1-C1	1-2	4
ARM, GOVERNOR	1-D2	1-21	2	CLIP, WIRE HARNESS	1-C6	1-12	16
ARM, VALVE ROCKER	1-C4	1-9	3	COIL ASSY., IGNITION	1-D2	1-20	1
ARRESTER, SPARK	1-C8	1-17	7	COLLAR B, AIR CLEANER	1-C8	1-16	9
(B)				COLLAR, AIR CLEANER	1-C8	1-16	8
BASE, CONTROL	1-D2	1-21	16	COLLAR, SET	1-C7	1-14	27
BEARING, RADIAL BALL (6202)	1-C2	1-4	16	CONTROL ASSY. (REMOTE)	1-D2	1-21	8
	1-C2	1-5	20	COVER ASSY., CRANKCASE	1-C2	1-5	3
BEARING, RADIAL BALL (6206)	1-C3	1-6	21	COVER, AIR CLEANER	1-C8	1-16	5
	1-C3	1-7	9	COVER, FAN *NH1* (BLACK)	1-C6	1-12	3
BOLT 2, STUD (8X32)	1-C1	1-2	13	COVER, FAN *R280* (POWER RED)	1-C6	1-12	3
BOLT, CONNECTING ROD	1-C4	1-8	5	COVER, HEAD	1-C1	1-2	6
BOLT, DRAIN PLUG	1-C2	1-4	6	CRANKSHAFT (Q-TYPE)	1-C3	1-7	3
BOLT, FLANGE (10X80)	1-C1	1-2	18	CUP, FUEL STRAINER	1-C7	1-14	21
BOLT, FLANGE (6X10)	1-C5	1-11	14	CYLINDER ASSY. (BALANCER+OIL ALERT)	1-C2	1-4	1
BOLT, FLANGE (6X12)	1-C2	1-4	15	CYLINDER HEAD	1-C1	1-2	1
BOLT, FLANGE (6X12) (CT200)	1-C2	1-4	17	(E)			
	1-C6	1-12	14	ELBOW, AIR CLEANER	1-C8	1-16	10
	1-C8	1-17	10	ELEMENT, AIR CLEANER (DUAL)	1-C8	1-16	2
	1-D2	1-21	23	EMBLEM	1-D3	1-23	2
BOLT, FLANGE (6X28)	1-D2	1-20	14	(F)			
BOLT, FLANGE (8X25)	1-D1	1-18	15	FAN, COOLING	1-D1	1-19	2
BOLT, FLANGE (8X35)	1-C2	1-5	19	FILTER (OUTER)	1-C8	1-16	3
BOLT, GOVERNOR ARM	1-D2	1-21	24	FILTER, FUEL	1-D1	1-18	7
BOLT, HEAD COVER	1-C1	1-2	11	FLOAT SET	1-C6	1-13	3
BOLT, PIVOT (8MM)	1-C4	1-9	14	FLYWHEEL	1-D1	1-19	9
BOLT, STUD (8X123)	1-C1	1-2	12	(G)			
BOLT-WASHER (6X22)	1-C8	1-16	15	GASKET SET	1-C6	1-13	1
BULK HOSE, FUEL (4.5X3000) (4.5X222)	1-D1	1-18	13	GASKET, CARBURETOR	1-C6	1-13	14
BULK HOSE, VACUUM (11X1000) (11X100)	1-C1	1-2	17	GASKET, CASE COVER	1-C2	1-5	2
(C)				GASKET, CYLINDER HEAD	1-C1	1-2	5
CAMSHAFT ASSY.	1-C4	1-9	1	GASKET, CYLINDER HEAD COVER	1-C1	1-2	7
CAP ASSY., NOISE SUPPRESSOR (NICHIIWA Y-EZ RTFM256)	1-D2	1-20	3	GASKET, ELBOW	1-C8	1-16	1
CAP ASSY., OIL FILLER	1-C2	1-5	4	GASKET, EX. PIPE	1-C8	1-17	6
	1-C2	1-5	5	GASKET, EX. PIPE (WACKER)	1-C8	1-17	6
CAP, FUEL FILLER	1-D1	1-18	5	GASKET, FUEL FILLER CAP	1-D1	1-18	16
	1-D1	1-18	17		1-D1	1-18	18
CAP, MUFFLER	1-C8	1-17	5	GASKET, FUEL STRAINER CUP	1-C6	1-13	11
CARBURETOR ASSY. (BE70B B)	1-C6	1-13	8	GASKET, INSULATOR	1-C6	1-13	15
CASE, RECOIL STARTER *NH1* (BLACK) (BLACK)	1-C5	1-10	2	GASKET, MUFFLER (ARRESTER)	1-C8	1-17	8
CASE, RECOIL STARTER *R280* (POWER RED)	1-C5	1-10	2	GASKET, OIL FILLER CAP	1-C2	1-5	7
CASE, RECOIL STARTER *R8* (BRIGHT RED)	1-C5	1-10	2	GASKET, VALVE	1-C7	1-14	20
CHAMBER SET, FLOAT	1-C7	1-14	28	GOVERNOR ASSY. (BALANCER)	1-C2	1-5	8
CHOKE SET	1-C6	1-13	7	GRIP, STARTER	1-C5	1-10	10
CLIP, GOVERNOR HOLDER	1-C2	1-5	15	GROMMET, AIR CLEANER	1-C8	1-16	6
CLIP, PISTON PIN (18MM)	1-C4	1-8	6	GROMMET, WIRE	1-D2	1-20	7
CLIP, TUBE	1-C6	1-12	2	GUIDE, EX. VALVE (OS)	1-C1	1-2	3
				GUIDE, VALVE (OS)	1-C1	1-2	2

DESCRIPTION INDEX

Description	Grid	Page	Ref	Description	Grid	Page	Ref
(H)				(P)			
HOLDER, CABLE	1-D2	1-21	14	PIN A, DOWEL (12X20)	1-C1	1-2	15
HOLDER, GOVERNOR WEIGHT	1-C2	1-5	10	PIN, DOWEL (8X12)	1-C2	1-5	18
(I)				PIN, GOVERNOR WEIGHT	1-C2	1-5	11
INSULATOR, CARBURETOR	1-C6	1-13	12	PIN, LOCK (10MM)	1-C2	1-4	14
(J)				PIN, PISTON	1-C4	1-8	3
JET SET, PILOT (#40)	1-C7	1-14	25	PIN, SPRING (2X12)	1-C7	1-14	23
JET, MAIN (#82)	1-C7	1-14	24	PIPE, EX.	1-C8	1-17	4
JET, MAIN (#85)	1-C7	1-14	24	PISTON (0.75)	1-C4	1-8	2
JET, MAIN (#88)	1-C7	1-14	24	PISTON (OS 0.25)	1-C4	1-8	2
JOINT, FUEL TANK	1-D1	1-18	2	PISTON (OS 0.50)	1-C4	1-8	2
(K)				PISTON (STD)	1-C4	1-8	2
KEY (6.3X6.3X43)	1-C3	1-7	8	PIVOT, ROCKER ARM	1-C4	1-9	5
KEY, SPECIAL WOODRUFF (25X18)	1-C3	1-7	16	PLATE, LEVER SETTING	1-C6	1-13	18
(L)				PLATE, PUSH ROD GUIDE	1-C4	1-9	13
LABEL, CAUTION	1-D3	1-23	1	PROTECTOR, EX. PIPE	1-C8	1-17	3
LEVER, CHOKE (STD)	1-C6	1-13	16	PROTECTOR, MUFFLER	1-C8	1-17	2
LEVER, CONTROL	1-D2	1-21	11	PULLEY, RECOIL STARTER	1-C5	1-10	3
LEVER, VALVE	1-C6	1-13	17	PULLEY, STARTER (SCREEN GRID)	1-D1	1-19	4
LIFTER, VALVE	1-C4	1-9	4	(R)			
(M)				RATCHET, STARTER	1-C5	1-10	4
MARK, CHOKE (EXTERNAL)	1-D3	1-23	7	RETAINER, EX. VALVE SPRING	1-C4	1-9	11
MARK, OIL ALERT (E)	1-D3	1-23	12	RETAINER, IN. VALVE SPRING	1-C4	1-9	10
MUFFLER	1-C8	1-17	1	RETAINER, SPRING	1-C5	1-10	8
(N)				RING SET, PISTON (0.75) (NIPPON)	1-C4	1-8	1
NOZZLE, MAIN	1-C6	1-13	10	RING SET, PISTON (0.75) (TEIKOKU)	1-C4	1-8	1
NUT, FLANGE (10MM)	1-C2	1-4	13	RING SET, PISTON (OS 0.25) (NIPPON)	1-C4	1-8	1
NUT, FLANGE (6MM)	1-C8	1-16	16	RING SET, PISTON (OS 0.25) (TEIKOKU)	1-C4	1-8	1
	1-D3	1-22	31	RING SET, PISTON (OS 0.50) (NIPPON)	1-C4	1-8	1
NUT, FLANGE (8MM)	1-C8	1-17	13	RING SET, PISTON (OS 0.50) (TEIKOKU)	1-C4	1-8	1
	1-C8	1-17	14	RING SET, PISTON (STD) (NIPPON)	1-C4	1-8	1
	1-D1	1-18	12	RING SET, PISTON (STD) (TEIKOKU)	1-C4	1-8	1
NUT, PIVOT ADJ.	1-C4	1-9	15	ROD ASSY., CONNECTING (STD)	1-C4	1-8	4
NUT, SELF-LOCK (6MM)	1-D2	1-21	26	ROD ASSY., CONNECTING (US 0.25)	1-C4	1-8	4
NUT, SPECIAL (16MM) (1)	1-D1	1-19	13	ROD, GOVERNOR	1-D2	1-21	3
(O)				ROD, PUSH	1-C4	1-9	2
O-RING (13.5X1.5) (ARAI)	1-C2	1-4	12	ROPE, RECOIL STARTER (#5X55")	1-C5	1-10	11
	1-D1	1-18	11	ROTATOR, VALVE	1-C4	1-9	12
OIL SEAL (30X46X8)	1-C2	1-4	10	RUBBER, SUPPORTER (107MM)	1-D1	1-18	1
	1-C2	1-5	16	(S)			
(O)				SCREW SET	1-C7	1-15	29
				SCREW SET B	1-C6	1-13	6
				SCREW SET, DRAIN	1-C7	1-14	26
				SCREW, CENTER	1-C5	1-11	13
				SCREW, PAN (3X6)	1-C7	1-14	22
				SCREW, PAN (5X16)	1-D2	1-21	30
				SCREW, PAN (5X28)	1-D2	1-21	29
				SCREW, TAPPING (4X6)	1-C8	1-17	12
				SCREW, TAPPING (5X8)	1-C8	1-17	11
					1-C8	1-17	16
					1-C8	1-17	17

DESCRIPTION INDEX

Description	Grid	Page	Ref	Description	Grid	Page	Ref
SCREW, THROTTLE STOP	1-C6	1-13	9				
SEAL, VALVE STEM	1-C4	1-9	16				
SEAT, VALVE SPRING	1-C1	1-2	8				
SHAFT, GOVERNOR ARM	1-C2	1-4	3				
SHROUD	1-C6	1-12	5				
SLIDER, GOVERNOR	1-C2	1-5	12				
SPACER, CARBURETOR	1-C6	1-13	13				
SPACER, CONTROL LEVER	1-D2	1-21	15				
SPARK PLUG (BPR5ES) (NGK)	1-C1	1-2	19				
SPARK PLUG (BPR6ES) (NGK)	1-C1	1-3	19				
SPARK PLUG (W16EPR-U) (DENSO)	1-C1	1-2	19				
SPARK PLUG (W20EPR-U) (DENSO)	1-C1	1-3	19				
SPRING, CABLE RETURN	1-D2	1-21	19				
SPRING, CONTROL ADJUSTING	1-D2	1-21	17				
SPRING, FRICTION	1-C5	1-10	5				
SPRING, GOVERNOR	1-D2	1-21	4				
SPRING, LEVER	1-D2	1-21	12				
SPRING, RATCHET	1-C5	1-10	7				
SPRING, STARTER RETURN	1-C5	1-10	6				
SPRING, THROTTLE RETURN	1-D2	1-21	5				
SPRING, VALVE	1-C4	1-9	9				
SPRING, VALVE LEVER	1-C7	1-14	19				
SPRING, WEIGHT RETURN	1-C4	1-9	6				
STARTER ASSY., RECOIL *NH1* (BLACK)	1-C5	1-10	1				
STARTER ASSY., RECOIL *R280* (POWER RED)	1-C5	1-10	1				
STARTER ASSY., RECOIL *R8* (BRIGHT RED)	1-C5	1-10	1				
SWITCH ASSY., ENGINE STOP	1-C6	1-12	12				
SWITCH ASSY., OIL LEVEL	1-C2	1-4	2				
(T)							
TANK, FUEL *NH1* (BLACK)	1-D1	1-18	3				
TANK, FUEL *NH31* (MCKINLEY WHITE)	1-D1	1-18	3				
(V)							
VALVE SET, FLOAT	1-C6	1-13	2				
VALVE, EX.	1-C4	1-9	8				
VALVE, IN.	1-C4	1-9	7				
(W)							
WASHER (8.2X17X0.8)	1-C2	1-4	7				
WASHER, CONTROL LEVER	1-D2	1-21	13				
WASHER, DRAIN PLUG (12MM)	1-C2	1-4	8				
WASHER, HEAD COVER	1-C1	1-2	14				
WASHER, PLAIN (6MM)	1-C2	1-5	17				
WEIGHT, BALANCER	1-C3	1-7	7				
WEIGHT, GOVERNOR	1-C2	1-5	9				
WINGNUT, TOOL BOX SETTING	1-C8	1-16	14				
WIRE, STOP SWITCH (370MM)	1-D2	1-20	11				
WRENCH, SPARK PLUG	1-D4	1-24	13				