

25A-128T063 Tiller/Edger (2002)  
General Assembly

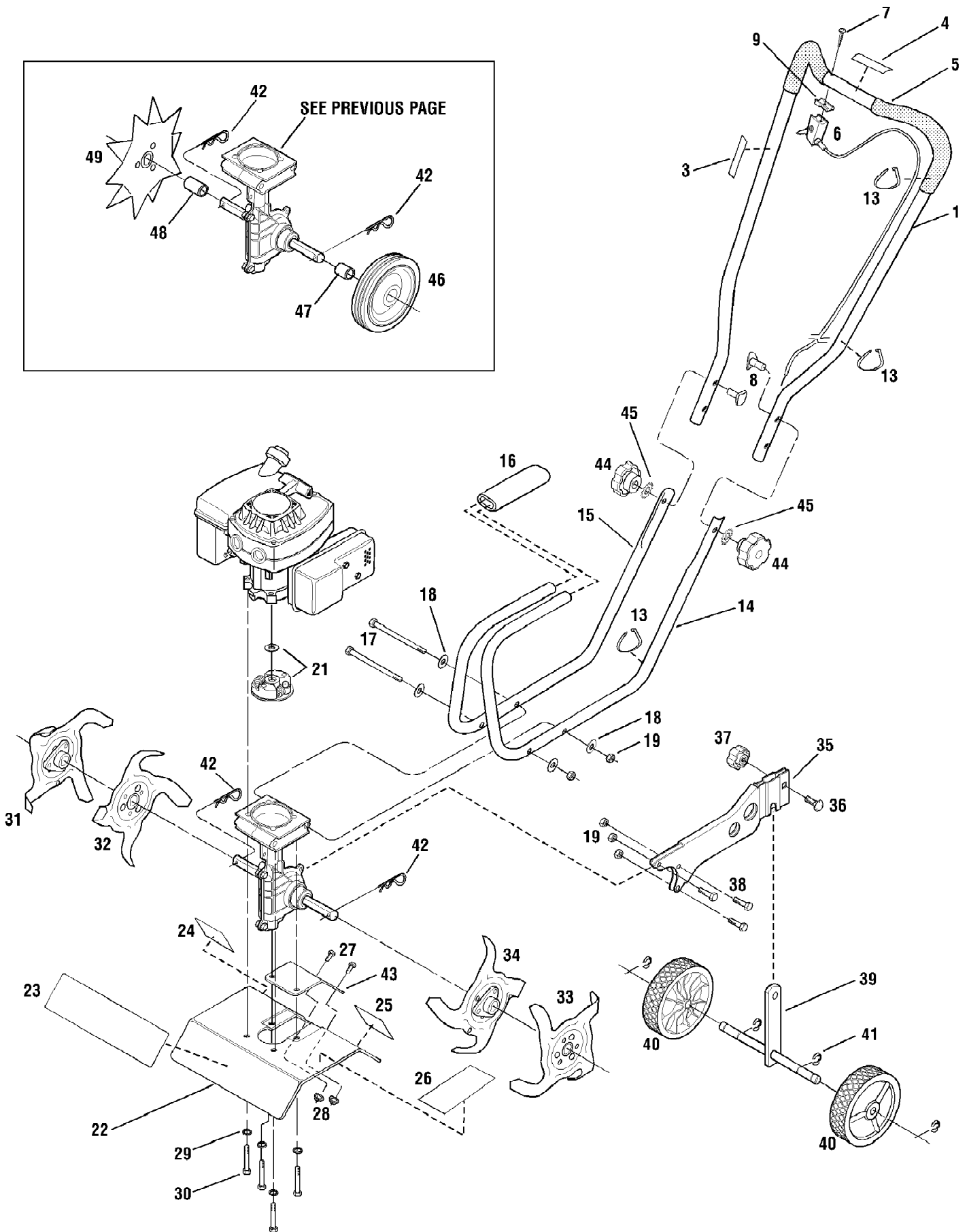

Ref #	Part Number	Qty	S/P/F	Description
1	1918303	1	/P	Handlebar Assembly
3	777I00007	1		Decal - Starting Stabilization
4	777I00009	1		Decal - Throttle/Tines Lever Operation
5	1917451	2		Handlebar Grip, PVC
6	1918123	1	S	Throttle/Tines Lever and Cable
7	1750608	1	/P	Pan Hd. Screw, #10-16 x 1-1/2
8	1731025	2	/P	Saddle Hd. Screw, 5/16-18 x 2
9	1909775	1	/P	Spacer, Throttle/Tines Lever
13	1763682	3	/P	Plastic Wire Tie
14	1918120	1	S	Lower Handlebar - Left-Side
15	1918121	1	S	Lower Handlebar - Right-Side
16	1909720	1	/P	Foam Sleeve
17	1983663	2	/P	Hex Hd. Screw, 1/4-20 x 5
18	1107381	2	S	Flat Washer, 1/4-20
19	712-0324	5	/P	Hex Locknut, 1/4-20
21	1909487	1	S	Clutch Rotor and Washer
22	1918124	1	/P	Tine Shield
23	777D06104	1		Decal - Logo
24	777S00012	1		Decal - Warning, Rotating Tines
25	777S30647	1		Decal - Warning, Hot Surfaces
26	777S00013	1		Decal - Caution, Operation Hazards
27	1186292	2		Hex Hd. Screw, #10-24 x 1/2
28	1186387	2	/P	Flange Locknut, #10-24
29	736-0329	4	S	Lock Washer, 1/4-20
30	710-0501	4	/P	Hex Cap Screw, 1/4-20 x 2
31	1909540	1	/P	Outer Tine - Right-Hand Side
32	1909539	1	/P	Inner Tine - Right-Hand Side
33	1909712	1	/P	Outer Tine - Left-Hand Side
34	1909711	1	/P	Inner Tine - Left-Hand Side
35	1909680	1		Wheel Bracket
36	GW-90077	1	S	Carriage Bolt
37	1909835	1	/P	Knob
38	710-0206	3	/P	Hex Hd. Screw, 1/4-20 x 1
39	1909517	1		Axle
40	1917754	2	/P	Wheel
41	GW-9532	4	/P	E-Ring
42	1185590	2	/P	Hitch Pin
43	1981022	1		Tine Hood Cover
44	1763767	2		Knob
45	1177038	2	/P	Lock Washer, 5/16
46	1903777	1	/P	Edger Wheel
47	1903778	1	/P	Bushing - Short
48	1983648	2	/P	Bushing - Long
49	1915054	1		Edger Tine

25A-128T063 Tiller/Edger (2002)  
Transmission Assembly

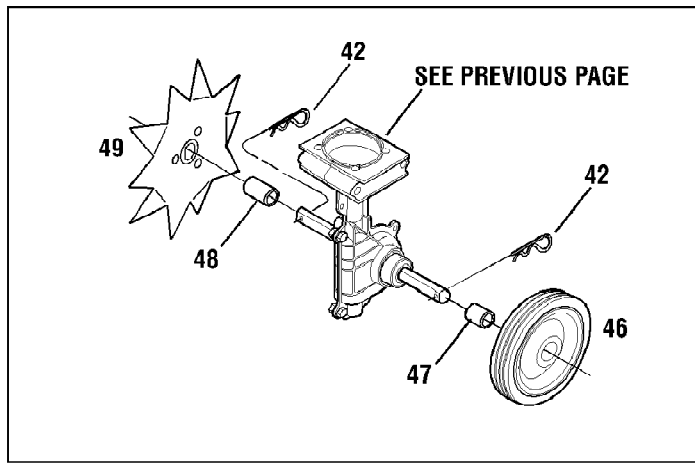
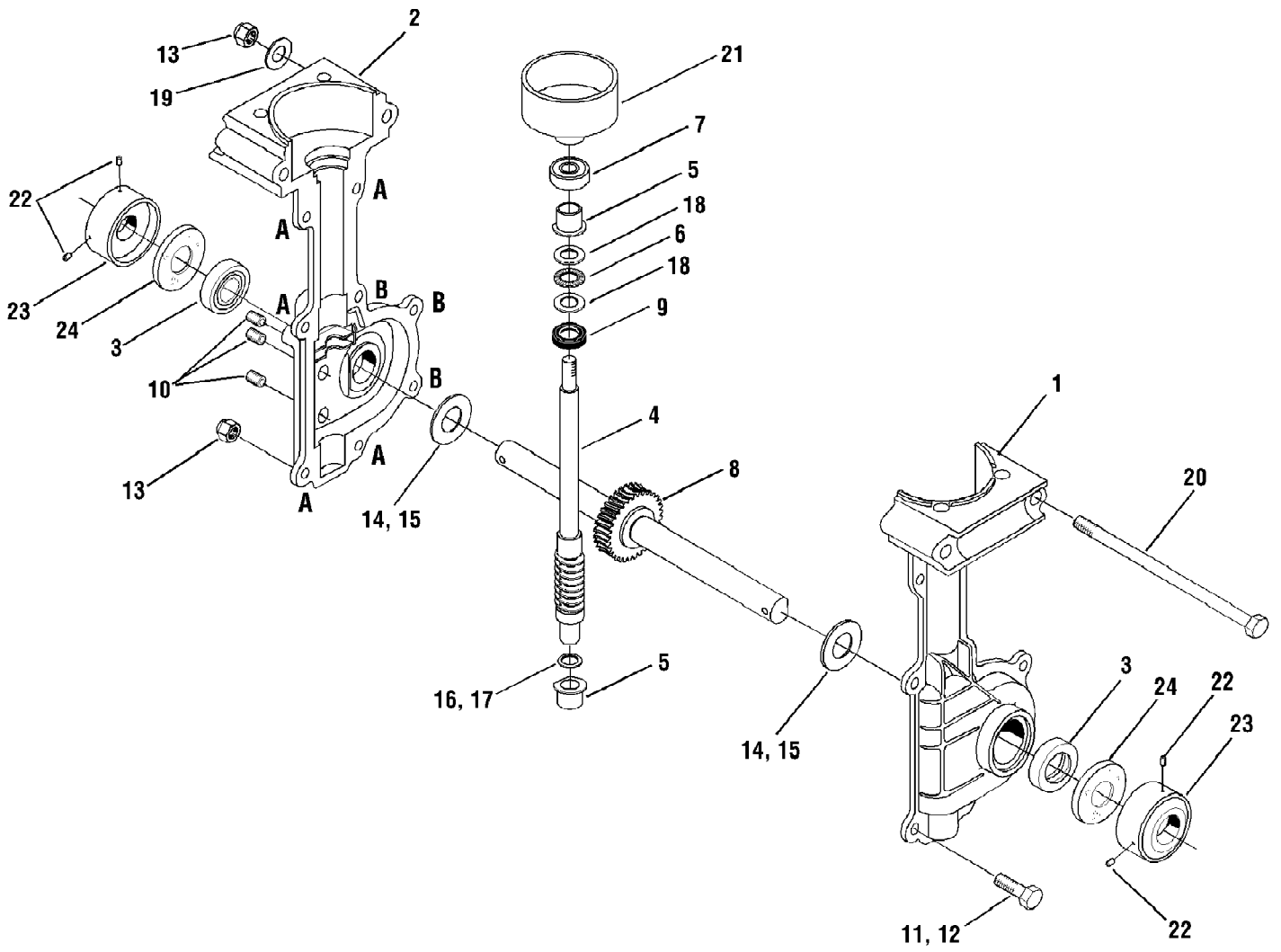

Ref #	Part Number	Qty	S/P/F	Description
1	1915039	1	/P	Transmission Case - left-side. (Incl. pressed-in bushing)
2	1915040	1	/P	Transmission Case - right-side. (Incl. pressed-in bushing)
3	1983632	2	S	Oil Seal
4	1918307	1	/P	Worm Input Shaft Assembly
5	1983731	2	/P	Input Bearing
6	1983636	1	/P	Thrust Bearing
7	1983637	1	/P	Ball Bearing
8	1904416	1	/P	Worm Gear Shaft Assembly
9	1909923	1	S	Oil Seal, Input
10	1185741	3	S	Plug, 1/8
11	710-0206	5	/P	Hex Screw, 1/4-20 x 7/8
12		1		UNKNOWN
13	712-0324	8	/P	Locknut, Nyloc, 1/4"-20
14	1983635	A/R	/P	Thrust Washer, output (.050")
15	1983640	A/R		Thrust Washer, output (.040")
16	1983641	A/R	/P	Thrust Washer, input (.020")
17	1983642	A/R	S	Thrust Washer, input (.035")
18	1983638	2	/P	Thrust Washer
19	736-0463	2	S	Flat Washer, .25 x .630 x .0515
20	1983663	2	/P	Hex Hd. Screw, 1/4-20 x 5
21	1909486	1	/P	Clutch Drum and Hub
22	1747166	4	/P	Set Screw, 1/4-28 x 3/8
23	1915055	2	/P	Dust Cover
24	1983713	2	/P	Felt Washer