

14AY809P063 (2001)
Axle & Wheels Front, Steering Assembly

Page 2 of 22

Ref #	Part Number	Qty	S/P/F	Description
1	683-0304	1	S	Lower Frame Assembly
2	710-0604A	1	/P	Self-tapping Screw, 16-18 x .625
3	783-0726A	1	S	RH Pivot Support Bracket
4	783-0727	1	S	LH Pivot Support Bracket
5	783-0728	1		Pivot Bar Bracket
6	710-0514	1	/P	Hex Cap Screw, 3/8-16 x 1 (Grade 5)
7	711-1408	1		RH Drag Link
8	711-1409A	1	/P	LH Drag Link
9	712-0240	1	S	Jam Nut, 7/16-20 (Grade 2)
10	712-0241	1	/P	Hex Nut, 3/8-24 (Grade 2)
11	712-0431	1	S	Flange Lock Nut, 318-16
12	712-0459	1	/P	Flange Lock Nut, 7/16-20
13	712-3004A	1	/P	Flange Lock Nut, 5/16-18
14	717-1550D	1	S	Steering Gear, 11/90 Ratio
15	717-1554	1		Steering Pinion Gear
16	723-0448A	1	S	Ball Joint, 7/16-20
17	736-0169	1	S	Lock Washer, 3/8
18	736-3084	1	/P	Flat Washer, .51 x 1.12 x .06
19	738-1001A	1	/P	Steering Shaft, .625 OD x 24.4
20	741-0475	1	S	Plastic Bushing, .38 ID
21	741-0656	1	S	Hex Flange Bearing, 5/8
22	738-0372	1	S	Shoulder Spacer, .38 ID
23	631-0027	1	S	Steering Wheel, 13.25
24	731-0220	1	S	Steering Wheel Cap, Round
25	638-0017	1	S	LH Axle Assembly, .75 Diameter
26	638-0018	1	S	RH Axle Assembly, .75 Diameter
27	719-0525B	1	S	Cast Iron Pivot Bar w/ Fittings, .75
28	712-0431	1	S	Flange Lock Nut, 3/8-16
29	714-0470	1	S	Cotter Pin
30	726-0214	1	/P	Push Cap, .625
31	736-0316	1	S	Flat Washer, .78 x 1.59 x .06
32	736-0316	1	S	Flat Washer, .78 x 1.59 x .06
33	736-0316	1	S	Flat Washer, .78 x 1.59 x .06
34	738-1011	1	S	Shoulder Screw, .5 x 2.2, 3/8-16
?35	710-0643	1	/P	Hex Bolt, 5/16-18 X 1
36	634-0183	1		Wheel Assembly Complete, 16 x 6.5 x 8
	634-0182	1	S	Rim Only w/ Plastic Bearing
	734-0255	1	S	Air Valve (Not Shown)
	734-1727	1	/P	Tire Only, Square Shoulder
37	731-2290	1	S	Hub Cap
38	783-0653D	1	S	Steering Support Bracket
39	738-0143	1	/P	Shoulder Screw, 3/8-16
40	736-0331	1	/P	Bell Washer, .39 x 1.13 x .062
41	710-1260A	1	/P	Self-tapping Screw, 5/16-18 x .75
42	736-0242	1	/P	Bell Washer, .34 x .872
43	710-0643	1	/P	Screw, 5/16-18 x 1

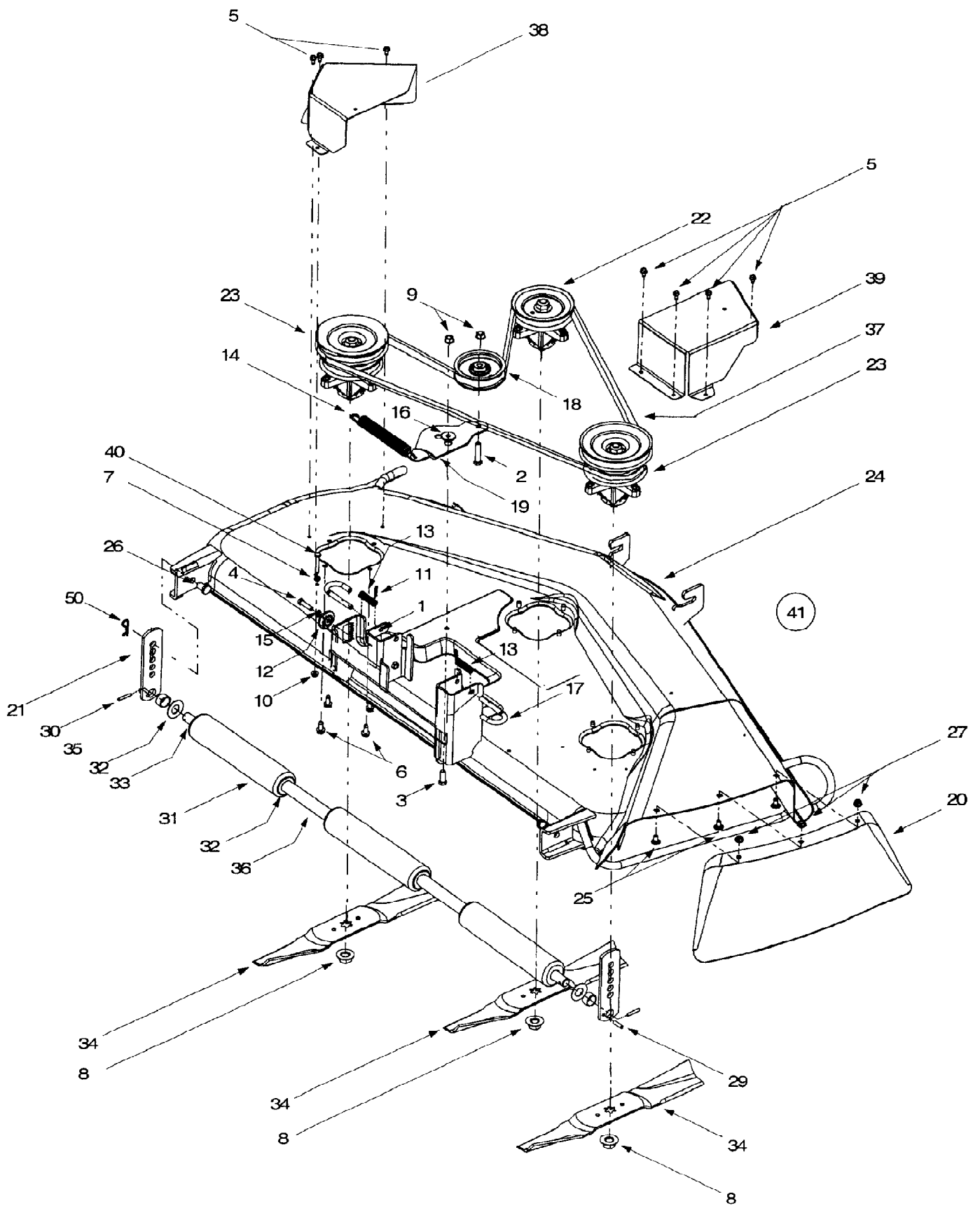

14AY809P063 (2001)
Deck Assembly P

Page 4 of 22

Ref #	Part Number	Qty	S/P/F	Description
1	710-0167	1	/P	Carriage Screw, 1/4-20 x .5
2	710-0347	1	/P	Hex Cap Screw, 3/8-16 x 1.75
3	710-0514	1	/P	Hex Cap Screw, 3/8-16 x 1.0
4	710-0528	1	/P	Hex Cap Screw, 5/16-18 x 1.25
5	710-0599	1	/P	Self Tapping Screw, 1/4-20 x .5
6	710-1260A	1	/P	Self Tapping Screw, 5/16-18 x .75
7	712-0291	1	S	Center Lock Nut, 1/4-20
8	712-0417A	1	/P	Hex Flange Nut, 5/8-18
9	712-0431	1	S	Flange Lock Nut, 3/8-16
10	712-3027	1	S	Hex Flange Lock Nut, 1/4-20
11	714-0104	1	S	Internal Cotter Pin, .072 x 1.12
12	717-1553A	1	S	Deck Adjustment Gear
13	732-0306	1	S	Compression Spring, .406 x .531 x 1.75
14	732-0594A	1	S	Extension Spring, .91 x 7.33
15	736-0119	1	S	Lock Washer, 5/16
16	738-0347	1	S	Shoulder Spacer, .625 x .169
17	747-1116	1	/P	Deck Release Pin
18	756-0627B	1	S	Flat Idler Pulley, 3.5 OD
19	783-0139A	1	S	Idler Bracket
20	12649	1		Chute Guard
21	12650	1		Height Adjustment Bracket
22	618-0268A	1	S	Center Spindle Assembly, 5 Dia.
	756-1187	1		Pulley Only
23	618-0269	1	S	Double Pulley Spindle Assembly
	756-1041	1		Double Pulley Only
24	683-0196	1	S	50-inch Deck Shell
25	710-0260A	1	/P	Carriage Bolt, 5/16-18 x .62
26	711-0332	1	S	Clevis Pin, .50 Dia. x .78
27	712-3004A	1	/P	Hex Flange Lock Nut, 5/16-18 (Grade 5)
?28	714-0145	1	S	Click Pin, .092 x 1.64
29	715-0108	1	/P	Spring Pin, 1/4 Dia. x 1
30	715-0246	1	S	Spring Pin, 3/16 x 1.25
31	731-0335	1		Deck Roller
32	736-0316	1	S	Flat Washer, .78 x 1.59 x .06
33	738-0295	1		Deck Roller Shaft, .75 Dia. x 47.12
34	742-0623	1	S	Blade, Star Center, 17.3
35	750-0212	1	S	Spacer, .752 x 1.0 x .53
36	750-0288	1	S	Spacer, .82 x 1.0 x 5.75
37	754-0291A	1	S	Deck Belt
38	783-0746	1		Belt Cover, L.H.
39	783-0793	1		Belt Cover, R.H.
40	710-3288	1		Hex Cap Screw, 1/4-20 x 1.62
41	753-0877	1		50-inch Deck Assembly Complete
50		1		UNKNOWN

14AY809P063 (2001)
Drive, Wheels Rear, Controls

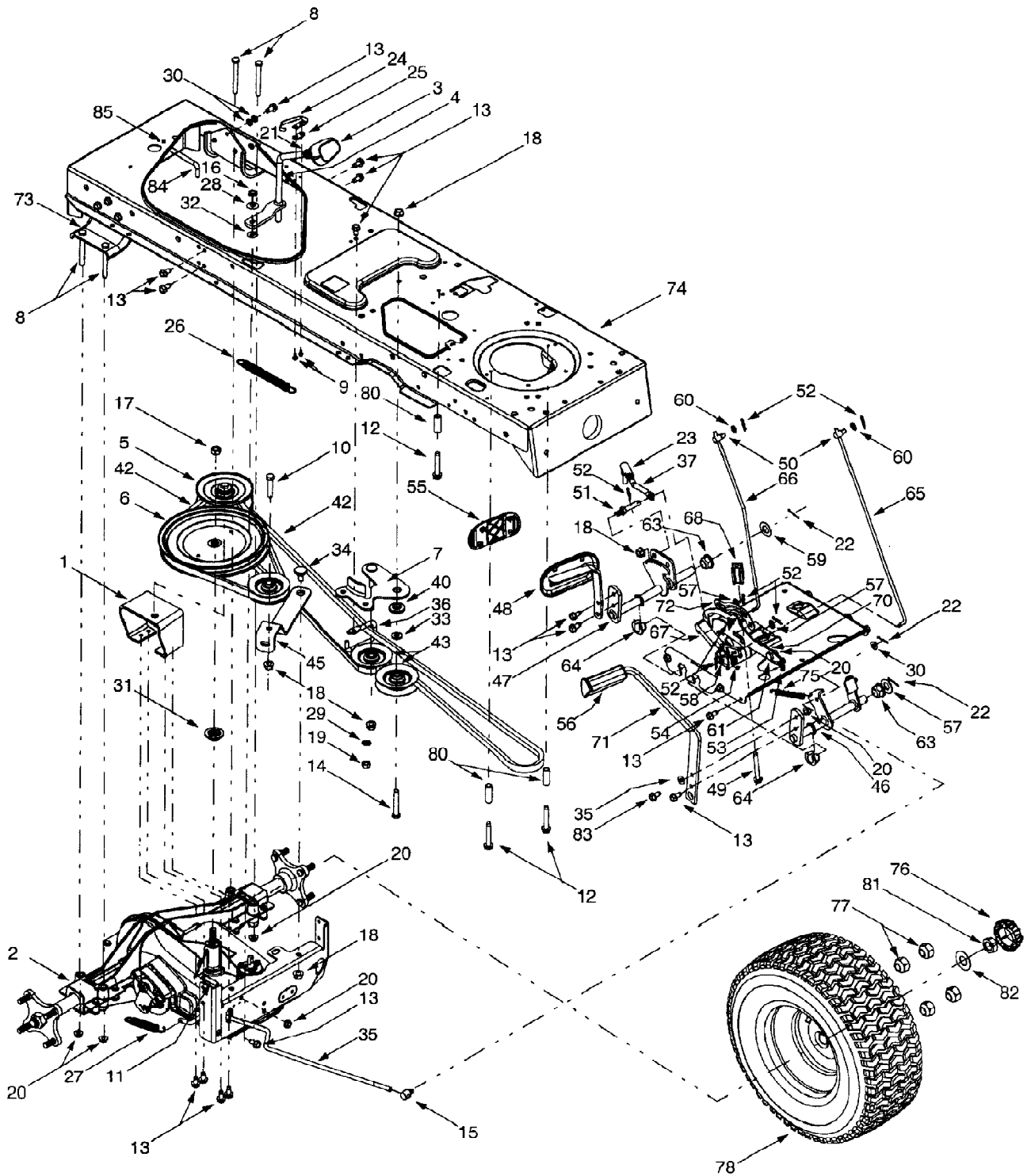

14AY809P063 (2001)
Drive, Wheels Rear, Controls

Page 6 of 22

Ref #	Part Number	Qty	S/P/F	Description
1	618-0375	1	S	Variable-speed Bracket Assembly
2	618-0376	1	S	Two-speed Transmission Assembly
3	631-0009A	1	S	Shfter Knob
4	647-0037	1		Shift Lever
5	656-0050	1		Variable-speed Pulley Assembly
6	756-0665	1	S	Transmission Pulley, 8.5
7	683-0251	1		Double-idler Bracket
8	710-0189	1	/P	Hex Cap Screw, 5/16-18 x 3
9	710-0227	1	/P	Self Tapping Screw, #8-18 x.5
10	710-0347	1	/P	Hex Cap Screw, 3/8-16 x 1.75
11	710-0528	1	/P	Hex Cap Screw, 5/16-18 x 1.25
12	710-0809	1		Self-tapping Screw, 1/4-20 x 1.25
13	710-0604A	1	/P	Self Tapping Screw, 5/16-18 x .625
14	710-3011	1	/P	Hex Cap Screw, 3/8-16 x 2.25
15	711-0677	1	S	Ferrule, 5/16 x .312 Dia.
16	712-0181	1	S	Hex Jam Nut, 3/8-16
17	712-0702	1	S	Hex Flange Nut, 7/16-20
18	712-0431	1	S	Flange Lock Nut, 3/8-16
19	712-0798	1	/P	Hex Nut, 3/8-16
20	712-3004A	1	/P	Flange Lock Nut, 5/16-18
21	712-3008	1	S	Hex Jam Nut, 3/8-16
22	714-0111	1	S	Cotter Pin
23	723-3018	1	S	Ball Joint, 3/8-24
24	725-1713	1		Spring Switch
25	726-0320	1	S	Insulator Nut Plate
26	732-0384	1	S	Extension Spring, .62 Dia. x 6.12
27	732-0716	1	S	Extension Spring, .59 OD x 4.0
28	736-0105	1	/P	Bell Washer, .401 x .870 x .063
29	736-0169	1	S	Lock Washer, 3/8
30	736-0275	1	S	Flat Washer, 5/16
31	718-0771	1	S	Pulley Hub, 1/2 Spline
32	736-0642	1		Flat Washer, .44 x .75 x .06
33	736-3010	1		Flat Washer, .407 x .812 x .135
34	738-0322	1	S	Shoulder Screw, .625 Dia. x .21
35	747-1122	1		Brake Rod
36	747-1123A	1	/P	Belt Guard
37	747-1127	1		Idler Adjustment Rod, 3/8
?38	710-1026	1	/P	Self-tapping Screw, 1/4-20 x 1.75
?39	747-1185	1		Transmission Belt Guard Rod
40	748-0416	1		Shoulder Spacer, .380 ID
42	754-0467	1	S	Drive Belt, Lower 90.8" Long
42	754-0468	1	S	Drive Belt, Upper 41.5" Long
43	756-0981A	1	S	Flat Idler, 2.75 OD
?44	783-0667A	1	S	Transmission Torque Bracket
45	783-0669	1	S	Idler Bracket
46	647-0031	1	S	Brake Control Shaft Assembly
47	647-0032	1	S	Speed Control Shaft Assembly
48	683-0266	1		Drive Pedal Assembly
49	710-1135	1		Self Tapping Screw, 5/16-18 x 2.5
50	711-0736	1	/P	Ferrule, 1/4-20
51	711-1363	1		Pin, 3/8-16 x 2.43
52	714-0104	1	S	Cotter Pin
53	732-0437	1		Compression Spring, .34 OD x 1.0

14AY809P063 (2001)
Drive, Wheels Rear, Controls

Page 7 of 22

Ref #	Part Number	Qty	S/P/F	Description
54	732-0955	1		Extension Spring, .5 OD x 1.41
55	735-0662	1		Drive Pedal Pad
56	735-3049	1	S	Brake Pedal Pad
57	736-0140	1	S	Flat Washer, .281 x .5 x .0625
58	736-0142	1	S	Flat Washer, 9/32 x 1/2 x 1/16
59	736-0187	1	/P	Flat Washer, .64 x 1.24 x .06
60	736-0204	1	/P	Flat Washer, .344 x .062 x .03
61	738-0155	1	S	Shoulder Screw, .437 x 1.62
?62	738-0507B	1	S	Shoulder Screw, .5 x .434
63	741-0225	1	S	Hex Flange Bearing
64	741-3065A	1	S	Split Hex Flange Bearing
65	747-1137	1		Cruise Control Rod
66	747-1138	1		Brake Lock Control Rod
67	748-0413	1		Cruise Latch
68	748-0415A	1	S	Spacer, 5/16 x 1.54
?69	783-0653B	1	S	Steering Support Bracket
70	783-0732	1	S	Drive Lockout Bracket
71	783-0773	1		Brake Pedal
72	783-0780A	1	S	Neutral Return Bracket
73	783-0693	1		Axle Bracket
74	683-0304	1	S	Lower Frame Assembly
75	732-0963	1		Extension Spring, .5 OD x 6.37
76	731-2290	1	S	Hub Cap
77	712-3050	1	/P	Lug Nut, 7/16-14
78	634-0202	1		Wheel Assembly Complete, 23 x 9.5 x 12
	634-3178	1		Rim Only
	734-0255	1	S	Air Valve
	734-1728	1	/P	Tire Only, Square Shoulder
?79	750-0768	1		Split Spacer, .25 x .37 x 1.32
80	750-0566	1	S	Spacer, .372 x .26 x 1.03
81	712-3026	1	S	Jam Nut, 3/4-16
82	736-0316	1	S	Flat Washer, .78 x 1.59 x .06
83	710-1260A	1	/P	Hex Screw, 5/16-18 x .75
84	747-1185	1		Transmission Belt Guard Rod
85	710-0599	1	/P	Self Tapping Screw, 1/4-20 x .5

14AY809P063 (2001)
Engine Accessories

Page 9 of 22

Ref #	Part Number	Qty	S/P/F	Description
1	710-0227	1	/P	Self-tapping Screw, #8-18 x .5
2	710-0599	1	/P	Self-tapping Screw, 1/4-20 x.5
3	710-0604A	1	/P	Self-tapping Screw, 5/16-18 x .625
4	710-1237	1		Screw, #10-32 x .625 (Model V809H)
5	710-1314	1	S	Socket Cap Screw, 5/16-18 x .625
6	710-1315	1	/P	Self-tapping Screw, 3/8-16 x 1.25
7	712-3017	1	S	Hex Nut, 3/8-16
8	721-0460	1		Exhaust Gasket (Model V809H)
9	726-0205	1	/P	Hose Clamp
10	736-0119	1	S	Lock Washer, 5/16
11	736-0300	1	S	Flat Washer
12	751B221535	1	/P	Casing Clamp (Model V809H)
13	751-0535	1		Fuel Line Hose
14	751-0564	1	S	Muffler Deflector
15	751-0616	1	S	Muffler, Twin Inlet (Model V809H)
16	751-0650	1	S	RH Exhaust Pipe (Model V809H)
17	751-0651	1	S	LH Exhaust Pipe (Model V809H)
18	751-3140	1	S	Oil Drain Valve
19	751-3141	1	S	Oil Drain Hose
20	751-3142	1		Oil Drain Cap
21	783-0615B	1	S	Muffler Heat Shield
22	783-0625B	1	S	Engine Heat Shield (Model V809H)
23	722-0263	1	S	Foam (fits over fuel line)
24	746-1086	1	S	Throttle Cable (Model V809H)
?25	746-1100	1	S	Throttle Cable (Model Y809P)
26	751-0645	1	S	RH Exhaust Pipe (Model Y809P)
27	751-0644A	1	S	LH Exhaust Pipe (Model Y809P)
28	751-0805	1	S	Muffler, Twin Inlet (Model Y809P)
29	783-1121	1		Engine Heat Shield (Model Y809P)
30	721-0377	1	S	Exhaust Gasket (Model Y809P)
31	712-3086	1	/P	Flange Nut, M8 x 1.25-6 (Model Y809P)

14AY809P063 (2001)
Hood & Electrical

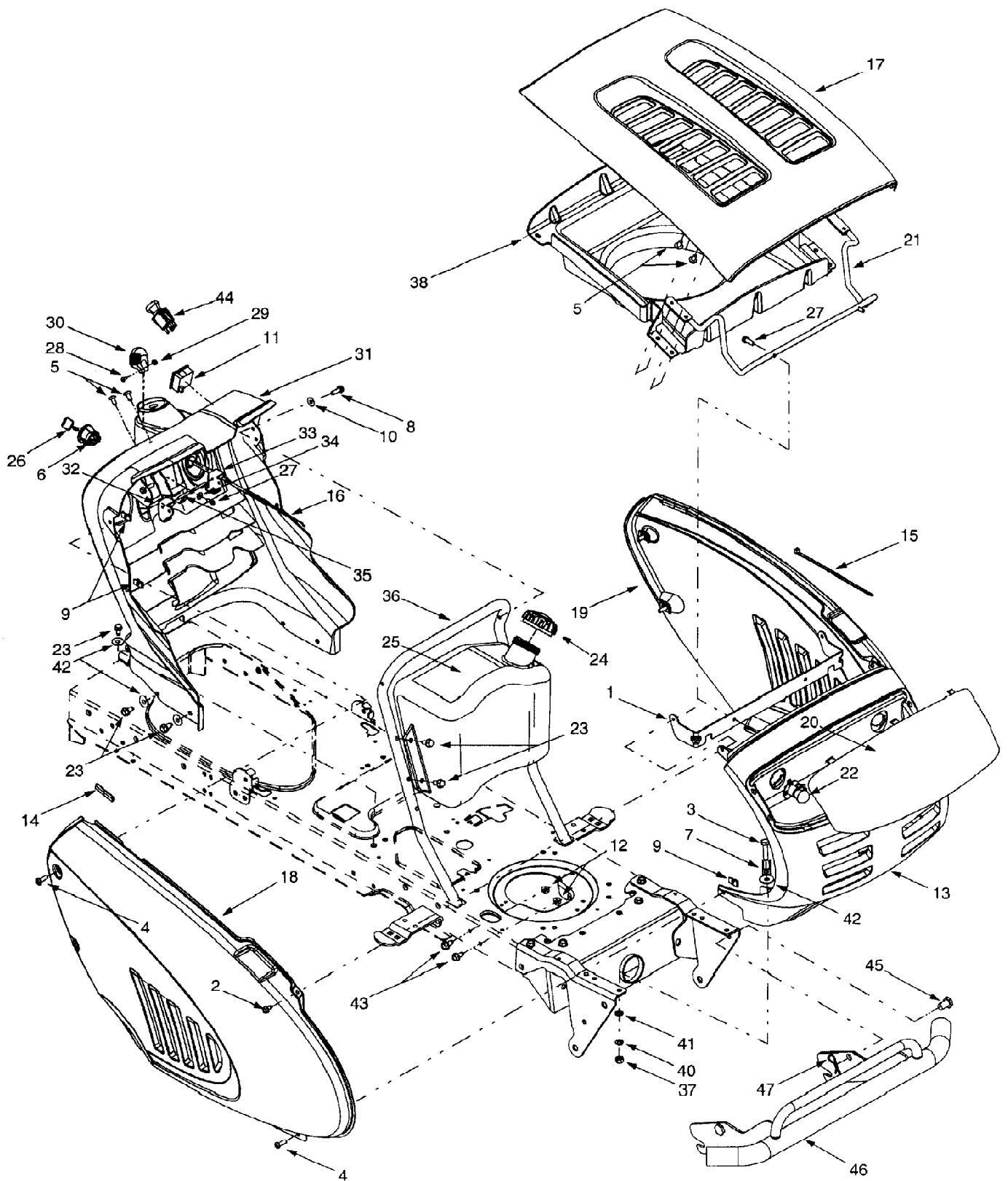

14AY809P063 (2001)
Hood & Electrical

Page 11 of 22

Ref #	Part Number	Qty	S/P/F	Description
1	783-1346	1	S	Grill Support Bracket (9-style)
2	710-0599	1	/P	Self-tapping Screw, 1/4-20 x .5
3	710-0528	1	/P	Hex Cap Screw, 5/16-18 x 1.25
4	710-0924	1	/P	Phillips Pan Screw, 1/4-20 x .75
5	710-1017	1	/P	Truss Phillips Screw, 1/4-20 x .625
6	725-1741	1	S	Ignition Switch
7	726-0272	1	/P	Clamp, 9/16
8	710-0642	1	/P	Self-tapping Screw, 1/4-20 x .75
9	712-0292	1	/P	U-type Speed Nut, 1/4-20
10	736-0270	1	/P	Bell Washer, .265 x .75 x .062
11	725-1976	1	S	Systems Indicator Monitor
12	712-3004A	1	/P	Hex Nut, 5/16-18
13	731-2119	1	S	Grille (9-style)
14	731-0511	1	/P	Trim Strip, 4
15	725-0175	1		Cable Tie, 3/16 x .05 x 7.4
16	746-1085	1	S	Choke Knob/Cable
17	783-0783	1	S	Hood (9-style)
18	783-0784	1		RH Side Panel (9-style)
19	783-0785	1		LH Side Panel (9-style)
20	731-2119	1	S	Headlight Lens (9-style)
21	747-1162	1		Hood Hinge Rod
22	625-0051	1	S	Headlight Assembly
23	710-0604A	1	/P	Self-tapping Screw, 5/16-18 x .625
24	751-0603	1	S	Fuel Cap
25	751-0658B	1		Fuel Tank, Three-gallon
26	725-1745	1	S	Ignition Key w/ plastic cover
	725-1744	1	S	Ignition Key w/o plastic cover
27	710-0895	1		Self-tapping Screw, 1/4-15 x .75
28	710-3217	1	/P	Truss Phillips Screw, #8-32 x .375
29	712-0142	1	/P	Hex Nut, #8-32
30	731-1857	1		Throttle Control Knob
31	731-2225	1	S	Dash Panel, 8/9-style, Electric PTO
32	731-2226	1		Cruise Control Button
33	731-2227	1		Parking Brake Button
34	736-0142	1	S	Flat Washer, 9/32 x 1/2 x 1/16
35	747-1196	1		Brake/Cruise Pivot Rod
36	749-1087A	1	S	Dash Support Tube
37	712-3010	1	S	Hex Nut, 5/16-18
38	731-2270	1	S	Hood Plenum (Model V809H)
	731-2271	1	S	Hood Plenum (Model Y809P)
?39	726-3046	1	/P	Ratchet Clip
40	736-0119	1	S	Lock Washer, 5/16
41	726-0201	1		Speed Nut, .3125
42	736-3078	1	/P	Flat Washer, .349 x 1.0 x .063
43	710-1238	1	/P	Screw, 5/16-18 x .875 (Grade 5)
44	725-1752	1	S	Electric PTO Switch
45	711-0332	1	S	Clevis Pin, .50 x .78
46	768-0010	1	S	Bumper Assembly
47	714-0145	1	S	Internal Cotter Pin
	629-0469A	1	S	Headlight Wire Harness
	629-1069	1		Tractor Wire Harness (Model Y809P)
	629-1071	1	S	Tractor Wire Harness (Model V809H)

14AY809P063 (2001)
PTO Electric

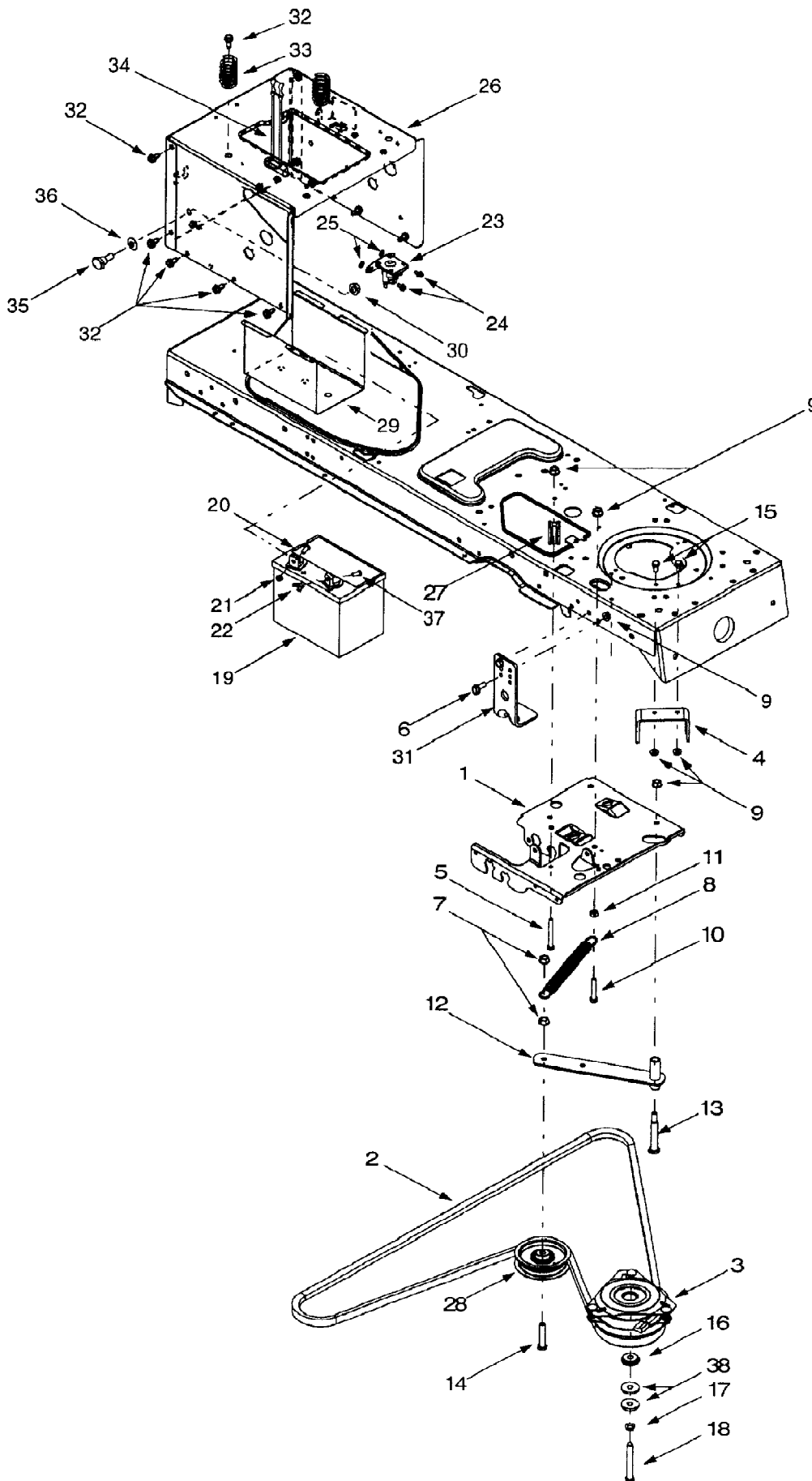

14AY809P063 (2001)
PTO Electric

Page 13 of 22

Ref #	Part Number	Qty	S/P/F	Description
1	783-0653D	1	S	Steering Support Bracket
2	754-0474	1	S	PTO Belt (Model V809H)
	754-0475	1	S	PTO Belt (Model Y809P)
3	717-1709	1	S	Electric PTO Clutch
4	783-1003	1	S	Electric Clutch Anti-rotation Bracket
5	710-0859	1	/P	Hex Cap Screw, 3/8-16 x 2.5
6	710-1238	1	/P	Hex Head Washer Screw, 5/16-18 x .875
7	712-0431	1	S	Flange Lock Nut, 3/8-16
8	732-0978	1		Extension Spring, .62 x 5.62
9	712-3004A	1	/P	Flange Lock Nut, 5/16-18
10	710-3180	1	/P	Hex Cap Screw, 5/16-18 x 1.75
11	712-3010	1	S	Hex Nut, 5/16-18
12	683-0294	1	S	Idler Bracket Assembly
13	738-3056	1	S	Shoulder Screw, 1/2 x 2.5
14	710-3144	1	/P	Hex Cap Screw, 3/8-16 x 2.0
15	710-3025	1	/P	Hex Cap Screw, 5/16-18 x .625
16	738-0785	1	S	Shoulder Spacer, 1.38 x .445 x .36
17	736-0171	1	S	Lock Washer, 7/16
18	710-3157	1	S	Hex Cap Screw, 7/16-20 x 3.25 (Grade 5)
19	725-1706	1	S	12-volt Battery, 270 CCA
20	710-0751	1	/P	Hex Cap Screw, 1/4-20 x .62
21	712-0271	1	/P	Hex Sems Nut, 1/4-20
22	712-3087	1	/P	Wing Nut, 1/4-20
23	725-1426	1	S	Solenoid, 12-Volt, 100 Amp
24	710-0599	1	/P	Self Tapping Screw, 1/4-20 x .5
25	736-0222	1	S	Lock Washer, 1/4
26	783-1031A	1		Hitch Plate
27	748-0415A	1	S	Spacer, 3/8 x 1.54
28	756-0627B	1	S	Idler Pulley, 3.5
29	783-0349	1		Battery Tray
30	712-0459	1	/P	Flange Lock Nut, 7/16-20
31	783-0891B	1		Deck Stop
32	710-0604A	1	/P	Self Tapping Screw, 5/16-18 x .625
33	732-3080	1	S	Compression Spring, 1.28 x 3.5
34	723-0444	1		Battery Strap
35	738-1020	1		Shoulder Screw, .625 x .5, 7/16-20
36	736-0407	1		Bell Washer, .45 x 1.0 x .062
37	738-1132	1		Shoulder Screw, 1/4-20, .25 x .15
38	736-0322	1	/P	Flat Washer, .45 x 1.25 x .164

14AY809P063 (2001)
Seat, Desk Lift, Frame

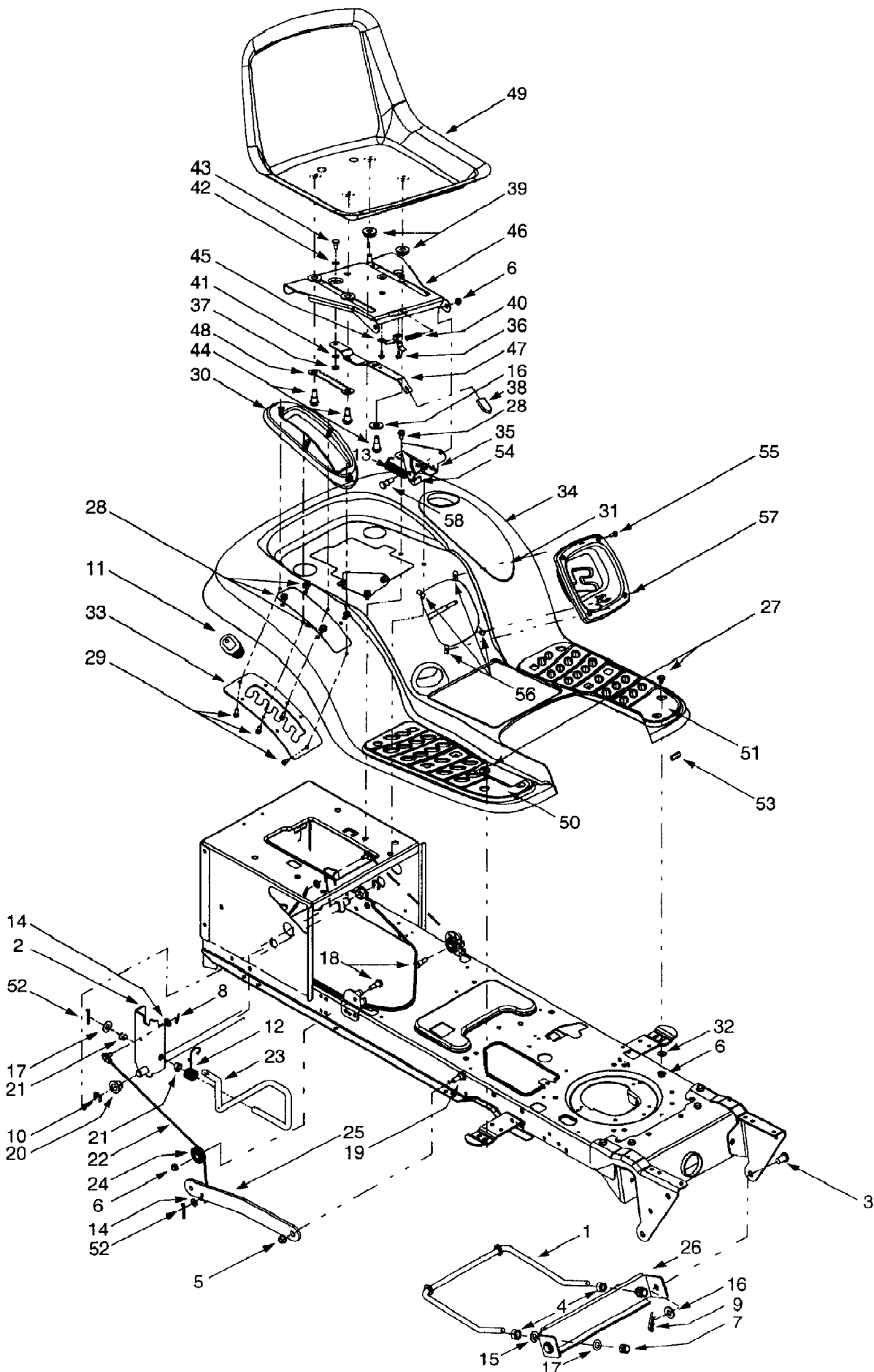

14AY809P063 (2001)
Seat, Desk Lift, Frame

Page 15 of 22

Ref #	Part Number	Qty	S/P/F	Description
1	747-1130A	1	S	Deck Stabilizer Rod
2	683-0197	1	S	Lift Shaft Assembly
3	711-0332	1	S	Clevis Pin, .5 x .78
4	712-0206	1	S	Hex Nut, 1/2-13
5	712-0431	1	S	Flange Lock Nut, 3/8-16
6	712-3004A	1	/P	Flange Lock Nut, 5/16-18
7	712-3083	1	/P	Hex Nut, 1/2-13
8	714-0104	1	S	Internal Cotter Pin
9	714-0145	1	S	Internal Cotter Pin
10	716-0106	1	/P	E-ring
11	720-0311	1		Handle Grip
12	732-0874	1	/P	Torsion Spring
13	732-1027	1		Extension Spring, .872 x 3.4
14	736-0275	1	S	Flat Washer, 5/16
15	736-0921	1	S	Lock Washer, 1/2
16	736-3019	1		Flat Washer, .31 x 1.062 x .134
17	736-3084	1	/P	Flat Washer, .51 x 1.12 x .06
18	738-0138A	1	/P	Hex Cap Screw, 5/16-18 x .62
19	738-0143	1	/P	Shoulder Screw, 3/8-16
20	741-0225	1	S	Hex Flange Bearing
21	741-0715	1	S	Snap Flange Bearing
22	746-0968	1		Lift Cable, 16.16
23	747-1111	1	S	Lift Handle
24	756-1154	1		Roller Pulley
25	783-0678A	1	S	Arm Lift
26	783-0720A	1	S	Deck Stabilizer Bracket
27	710-0260A	1	/P	Carriage Bolt, 5/16 x .62
28	710-0604A	1	/P	Self-tapping Screw, 5/16-18 x .625
29	710-0895	1		Self-tapping Screw, 1/4-15 x .75
30	731-1990	1		Lift Lever Cover
31	731-1993	1		Cover w/ Cup Holder
32	736-3078	1	/P	Flat Washer, .349 x 1.0 x .063
33	783-0677	1	S	Lift Adjustment Bracket
34	783-1280	1		Fender
35	783-0715A	1	S	Seat Mounting Bracket
36	710-1268	1	/P	Screw, #10-16 x .375
37	712-3027	1	S	Hex Flange Lock Nut, 1/4-20
38	720-0309A	1	/P	Seat Adjuster Grip
39	731-1989	1		Spacer
40	732-0499	1		Compression Spring, .41 x 1.5
41	736-0175	1	S	Spring Washer, .265 x .562 x .025
42	736-0204	1	/P	Flat Washer, .344 x .62 x .03
43	738-0137A	1	S	Shoulder Screw, .340 x .285, 1/4-20
44	738-1007	1		Shoulder Screw, .50 x .50, 3/8-16
45	783-0611	1		Seat Stop
46	783-0738	1	S	Seat Pivot Bracket
47	783-0739	1		Seat Adjustment Lever
48	783-0753	1		Seat Adjustment Selector
49	757-0350	1	S	High Back Seat w/ Drain Holes, Black
50	735-0656	1		RH Foot Pad
51	735-0657	1		LH Foot Pad
	726-3046	1	/P	Foot Pad Clips
52	714-0111	1	S	Cotter Pin

14AY809P063 (2001)
Seat, Desk Lift, Frame

Page 16 of 22

Ref #	Part Number	Qty	S/P/F	Description
53	731-0511	1	/P	Trim Strip
54	783-0209	1	S	LH Seat Lift Bracket
	17239A	1	S	RH Seat Lift Bracket
55	710-0924	1	/P	Phillips Pan Screw, 1/4-20 x .75
56	712-0292	1	/P	U-type Speed Nut, 1/4-20
57	731-2480	1	S	Shift Lever Cover
58	738-0296	1	S	Shoulder Screw, .437 x .286

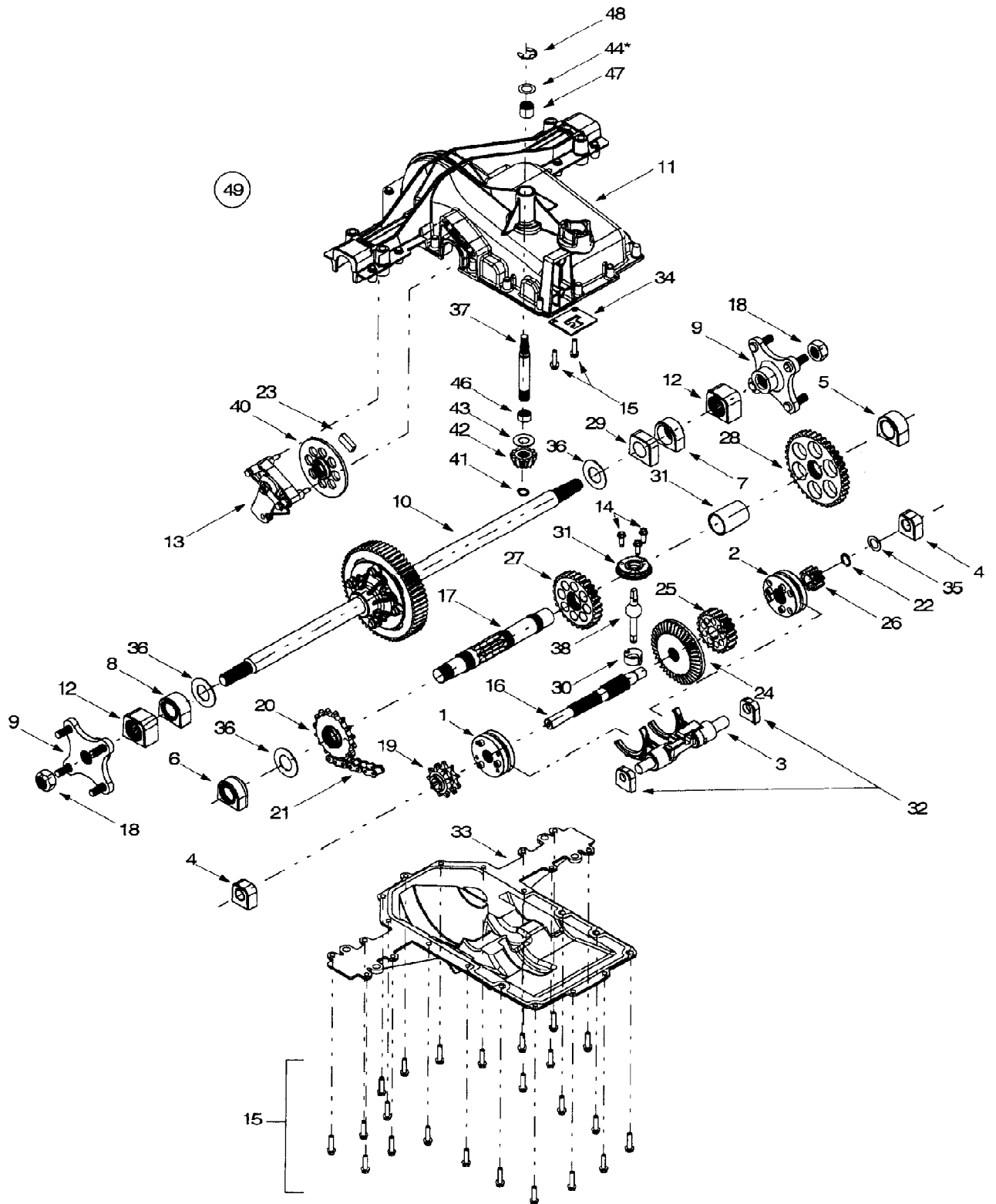

14AY809P063 (2001)
Transmission 618-0376

Page 18 of 22

Ref #	Part Number	Qty	S/P/F	Description
1	618-0225	1		Reverse Collar Assembly
2	618-0226	1		Hi-Lo Collar Assembly
3	618-0227A	1		Shift Fork Assembly
4	618-0284	1		Detent Block Assembly
5	618-0285	1		Output Bearing Block Assembly
6	618-0286	1		Output Seal Bearing Block Assembly
7	618-0287	1		Inboard Sealed Axle Block Assembly
8	618-0302	1		Inboard Sealed Axle Block Assembly
9	618-0365	1	S	Wheel Hub Assembly
10	618-0368	1	S	Differential Axle Assembly
11	719-0379A	1	S	Upper Housing
12	641-0002A	1	/P	Axle Bearing Block Assembly
13	661-0012	1	S	Brake Assembly
14	710-0642	1	/P	Self-tapping Screw, 1/4-20 x .75
15	710-0788	1	/P	Self-tapping Screw, 1/4-20 x 1.0
16	711-1051A	1	/P	Drive Shaft
17	711-1216	1		Output Shaft
18	712-1329	1	/P	Nut, 3/4-16
19	713-0446	1	S	9-tooth Sprocket
20	713-0447	1	S	16-tooth Sprocket
21	713-0448	1	S	22-link Chain, .625
22	716-0131	1	S	External Snap Ring
23	717-0678	1	S	Brake Pad
24	717-1438	1	S	41-tooth Bevel Gear
25	717-1439	1	S	20-tooth Spur Gear
26	717-1440	1		10-tooth Spur Gear
27	717-1441	1		27-tooth Spur Gear
28	717-1442	1		37-tooth Spur Gear
29	718-0500	1		Inner Axle Bearing Block
30	718-0504	1		Shifter Insert
31	718-0505	1		Shifter Cover
32	718-0537	1		Shifter Bearing Block
33	719-0385	1		Lower Housing
34	718-0540	1		Lockout Plate
35	736-0337	1	S	Flat Washer, 5/8 x 1.0
36	736-3046A	1		Flat Washer, 1.01 x 1.86 x .060
37	711-1235	1		Input Shaft
38	747-1140	1	/P	Shift Lever
?39	750-1033A	1		Spacer, 1.13 x 1.38 x 1.968
40	761-0215	1		Disc Brake
41	716-0114	1	S	Retaining Ring, .56
42	717-1463	1	S	13-tooth Bevel Gear
43	736-0335	1	S	Flat Washer
44	736-0336	1	S	Flat Washer, 5/8 x 1.0 x .030
	736-0337	1	S	Flat Washer, 5/8 x 1.0 x .040
	736-0349	1	S	Flat Washer, 5/8 x 1.0 x .020
46	741-0335	1	S	Needle Bearing
47	741-0696	1	/P	Needle Bearing
48	716-0231	1	S	E-ring, .75
49	618-0376	1	S	Transmission Assembly Complete

14AY809P063 (2001)
Transmission 618-0376A

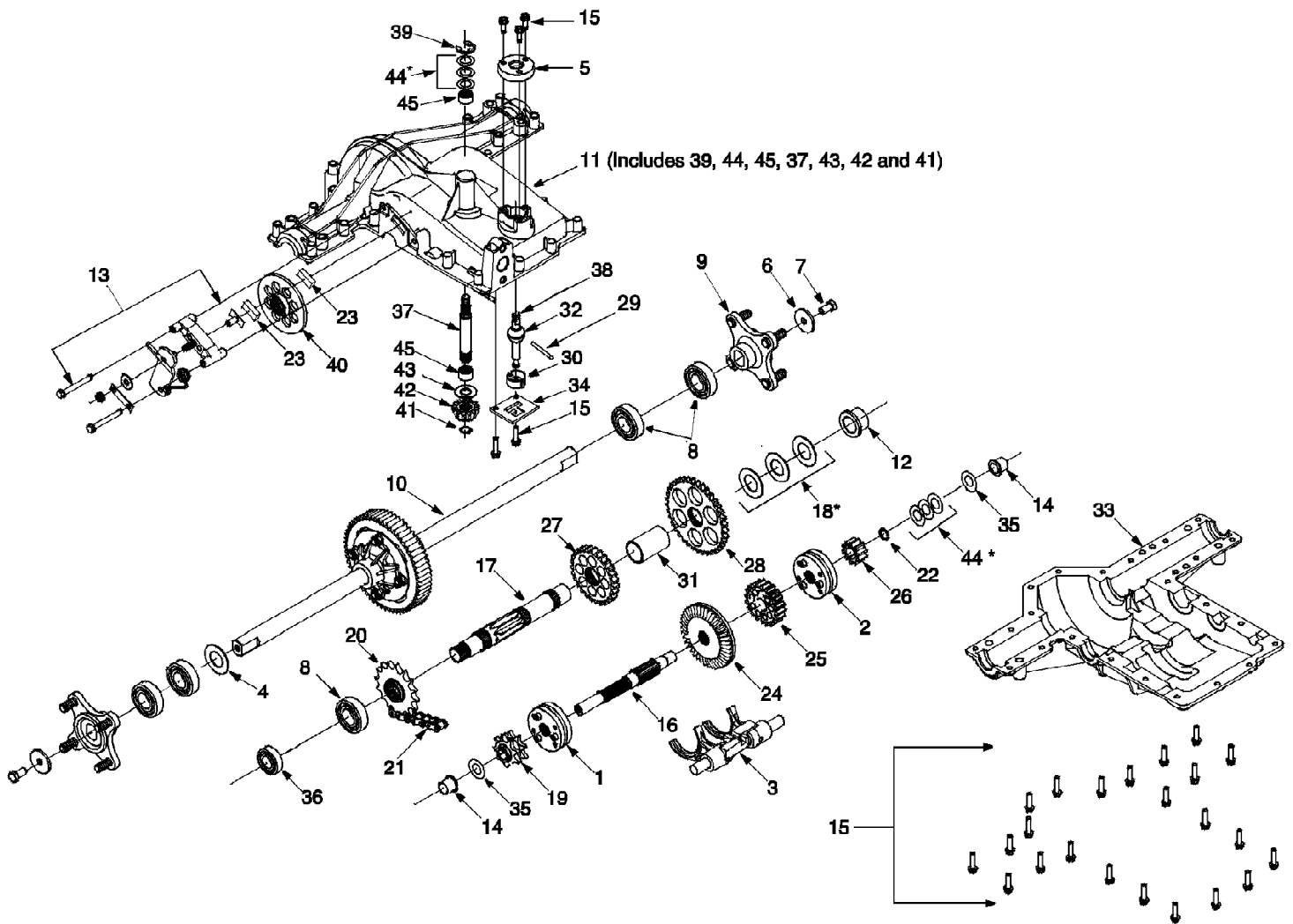

14AY809P063 (2001)
Transmission 618-0376A

Page 20 of 22

Ref #	Part Number	Qty	S/P/F	Description
1	618-0225	1		Reverse Collar Assembly
2	618-0226	1		Hi-Lo Collar Assembly
3	618-04156	1	S	Shift Fork Assembly
4	736-0745	1	/P	Flat Washer, 1.01" x 1.56" x .060"
5	718-04053	1	S	Shifter Cover
6	736-0227	1	S	Flat Washer
7	710-3119	1	/P	Lock Bolt, 3/8"-16 x 0.75"
8	741-0681	1		Ball Bearing
9	618-04115	1		Wheel Hub Assembly, Double D
10	618-04142	1		Differential Axle Assembly
11	619-04081	1	S	Upper Housing Assembly
12	741-04086	1		Flanged Bearing
13	661-0012	1	S	Brake Assembly
14	741-04085	1		Flanged Bearing
15	710-0788	1	/P	Self Tapping Screw, 1/4"-20 x 1.00"
16	711-1051A	1	/P	Drive Shaft
17	711-1216	1		Output Shaft
18	736-0715	1	F	Flat Washer, 1.12" x 1.75" x .03"
19	713-0446	1	S	9-Tooth Sprocket
20	713-0447	1	S	16-Tooth Sprocket
21	713-0448	1	S	22 Link Chain, .625 P
22	716-0131	1	S	External Snp Ring
23	717-0678	1	S	Brake Pad
24	717-1438A	1	S	41-Tooth Bevel Gear
25	717-1439A	1	S	20-Tooth Spur Gear
26	717-1440	1		10-Tooth Spur Gear
27	717-04109	1		27-Tooth Spur Gear
28	717-04110	1		37 Tooth Spur Gear
29	715-04017A	1	S	Dowel Pin
30	718-0504	1		Shifter Insert
31	750-04244	1		Spacer
32	718-04066	1	S	Spherical Bearing, 1.00"
33	719-04083	1	S	Lower Housing
34	718-0540	1		Lockout Plate
35	736-0167	1	S	Flat Washer, .656" x 1.25" x .02"
36	721-04031	1	S	Oil Seal, 1.00" Shaft x 1.499" Bore
37	711-1235	1		Input Shaft
38	711-04215	1	S	Shift Lever
39	716-0231	1	S	E-Ring, .75"
40	761-0215	1		Disc Brake
41	716-0114	1	S	Retaining Ring, .56" Dia. Shaft
42	717-1463A	1	/P	13-Tooth Bevel Gear
43	736-0335	1	S	Flat Washer,
44	736-0336	1	S/F	Flat Washer, 5/8" x 1.0" x .030"
	736-0337	1	S/F	Flat Washer, 5/8" x 1.0" x .040"
	736-0349	1	S/F	Flat Washer, 5/8" x 1.0" x .020"
	736-0494	1	F	Flat Washer, 5/8" x 1.0" x .035"
	736-0495	1	S/F	Flat Washer, 5/8" x 1.0" x .025"
45	741-0335	1	S	Needle Bearing

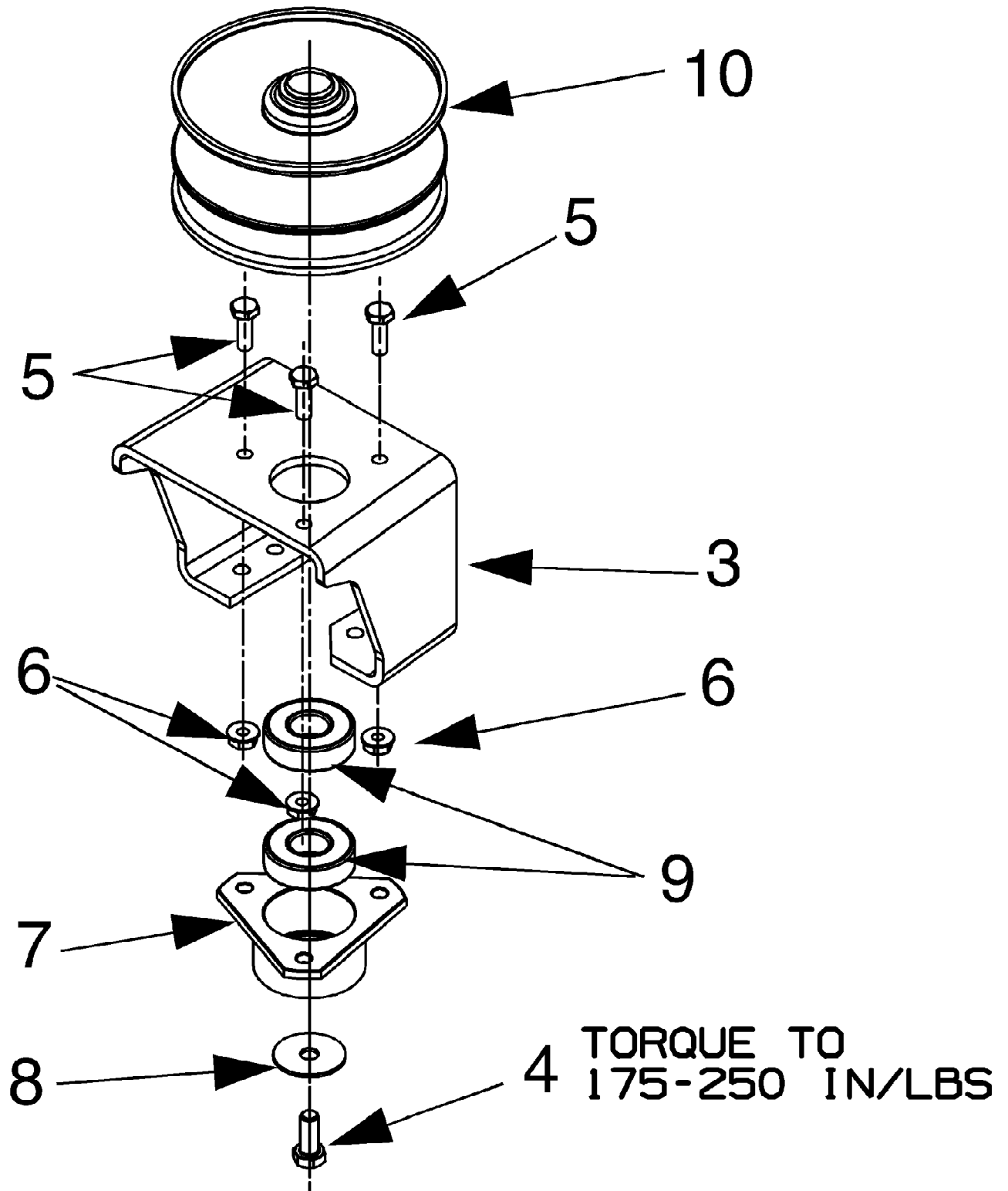

14AY809P063 (2001)
Variable Speed Pulley

Page 22 of 22

Ref #	Part Number	Qty	S/P/F	Description
2	710-0726	4	/P	AB SCREW: 5/16-12 x 0.75 (Self-Tap)
3	618-04200	1		VARIABLE SPEED BRACKET
4	710-0627	1	/P	LOCK BOLT, 5/16"-24 x 0.75"
5	710-3015	3	/P	HEX BOLT, 1/4"-20 x 0.75"
6	712-3027	3	S	FLANGED LOCK NUT
7	718-04012	1	/P	BEARING CUP
8	736-0362	1	/P	FLAT WASHER
9	741-0600	2	S	BALL BEARING
10	656-04015	1	S	VARIABLE SPEED PULLEY