

20459 PONY I 5HP STD (S/N P1001-P101750)
ENGINE, PULLEYS & BELTS

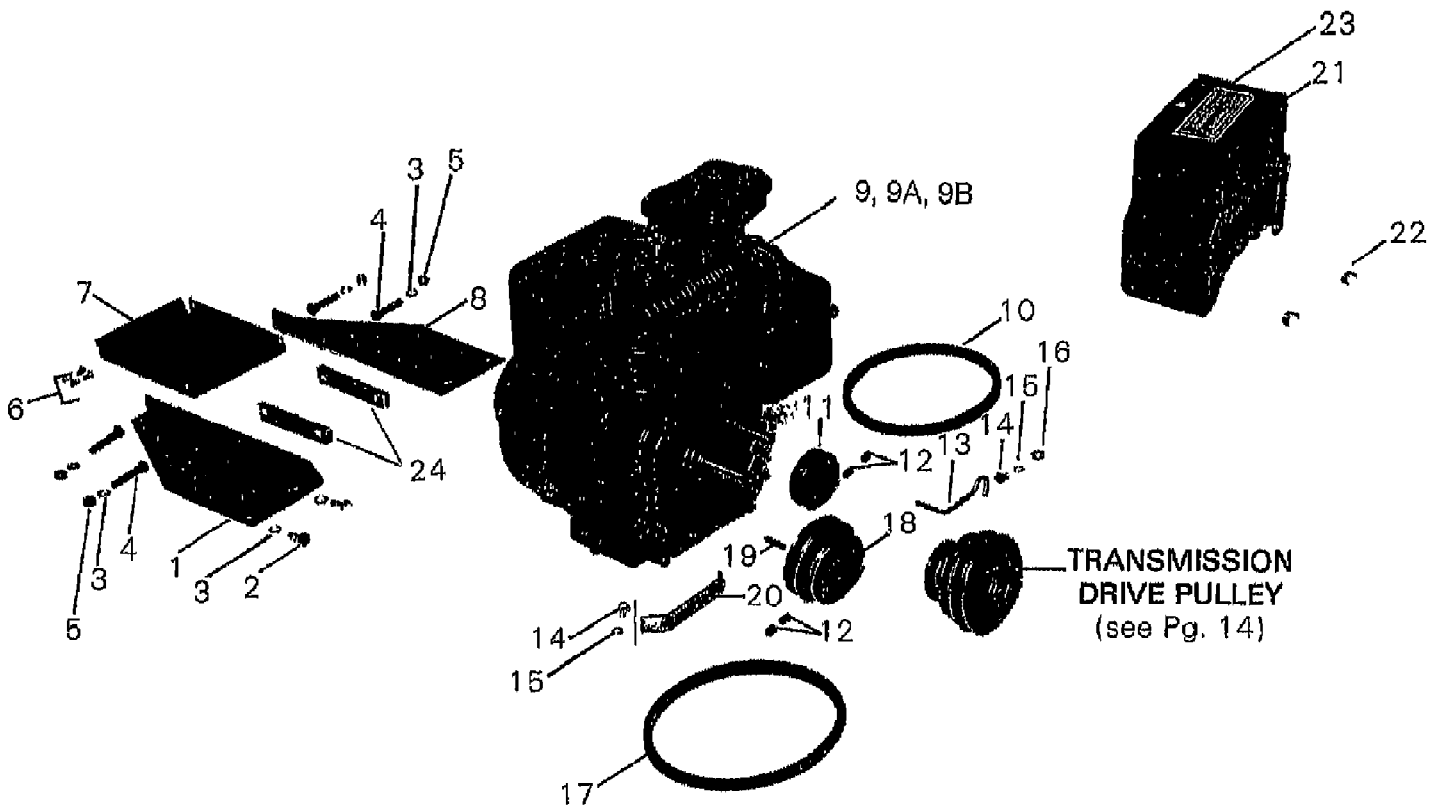

20459 PONY I 5HP STD (S/N P1001-P101750)
ENGINE, PULLEYS & BELTS

Page 2 of 16

Ref #	Part Number	Qty	S/P/F	Description
1	20340-01	0	F	BRKT-ENG MTG LT
2	9703	0		SCR-HHC 5/16-18X.75 GR 5 ZP
3	9912	0		WASHER-LK .312 ZP
4	9758	0		SCR-HH 5/16-18X1.5 G5 ZP
5	9801	0		NUT-HEX 5/16-18 ZP
6	9768	0		SCR-HH SEMS 10-32 X .5 (SEMS W/PERMANENT WASHER)
7	20339	0		PAN-ENG BRKT PNT
8	20340-02	0	F	BRKT-ENG MTG RT
9	0	0	F	ENGINE, BRIGGS & STRATTON, STD. RECOIL START, 4HP, MODEL 100292, TYPE 0536-01
9A	0	0		ENGINE, BRIGGS & STRATTON, STD. RECOIL START, 5HP, MODEL 130292, TYPE 0793-01
9B	0	0		ENGINE, BRIGGS & STRATTON, ELEC. START, 5HP, MODEL 130297, TYPE 0782-01
10	9200	0		BELT-V - REVERSE (SEE V-BELT SET)
11	9203	0		PULLEY-ENG MACH
12	9763	0		SCR-SS 5/16-18X.375
13	20366	0		GUIDE-BELT FWD
14	9701	0		SCR-HH 1/4-20X.75 G5 ZP
15	9910	0		WASHER-LK .25 ZP
16	9900	0		WASHER-FLAT 1/4 SAE
17	9201	0		BELT-V - FORWARD (SEE V-BELT SET)
18	20316	0		KIT-ENG PULLEY PONY
19	9301	0	S	KEY-.188 SQX1.0
20	20367	0		GUIDE-BELT REV
21	20360	0		WELD-BELT SHROUD
22	9822	0		NUT-WING/LK 1/4-20 ZP
23	20412	0		DECAL-BELT POSITION
24	20340-05	0		SHIM-4.38X.88X.134 (NON-CURRENT PART - CONTACT FACTORY)
	20402	0	F	BELT-V (SET)

20459 PONY I 5HP STD (S/N P1001-P101750)
FORWARD/REVERSE IDLER ASSEMBLY

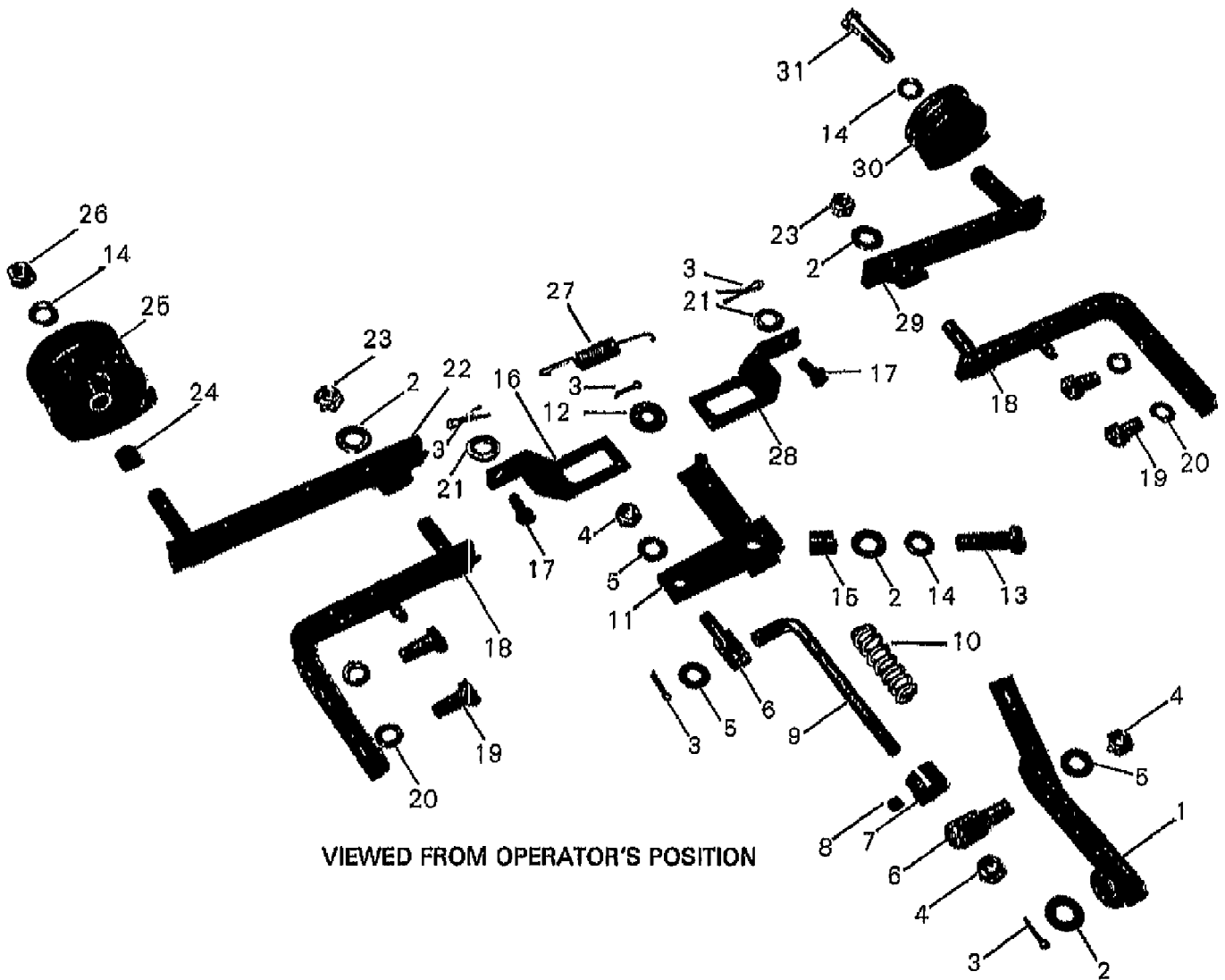

VIEWED FROM OPERATOR'S POSITION

COMPLETE
IDLER ASSEMBLY

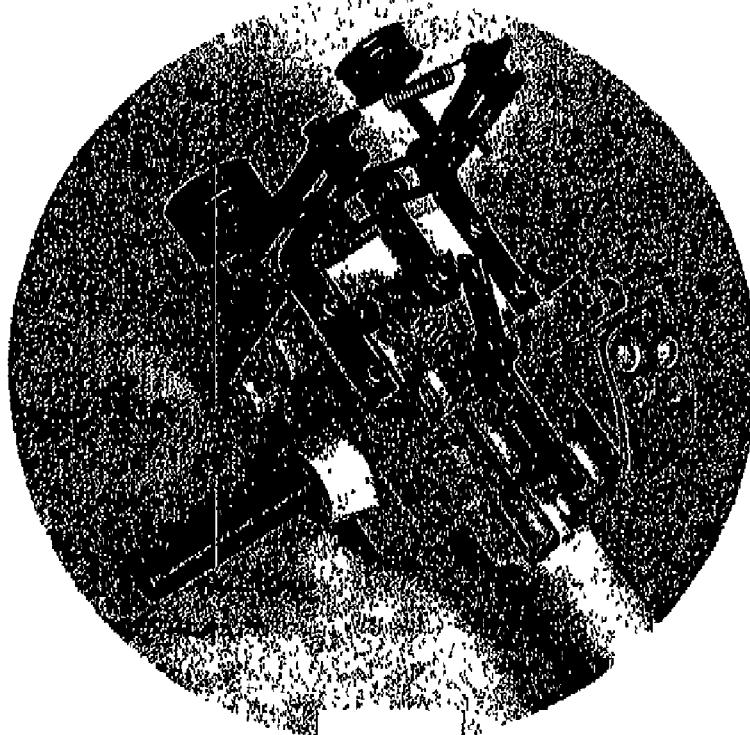

20459 PONY I 5HP STD (S/N P1001-P101750)
FORWARD/REVERSE IDLER ASSEMBLY

Page 4 of 16

Ref #	Part Number	Qty	S/P/F	Description
1	20376	0		LEVER-WELD REAM (FORWARD/REVERSE)
2	9904	0	S	WASHER-FLAT 3/8 SAE
3	9341	0		PIN-COTTER .09X.625
4	9808	0		NUT-H/LK 5/16-18
5	9902	0		WASHER-FLAT 5/16 SAE
6	20354	0		SWIVEL
7	20347	0		COLLAR-ADJUST
8	9762	0		SCR-SS 1/4-20 X .25 (WITH BRASS TIP)
9	20375	0		ROD-CONNECTING
10	20403	0		SPRING-.48 X 3
11	20345	0		BELLCRANK-WELD ZP
12	20378	0		WASHER-#1X .316 X.062 ZP
13	9712	0	F	SCR-HH 3/8-16X1.25
14	9913	0		WASHER-LK .375 @ DEPL
15	20352	0		BUSHING-.5X.375X.53 (FITS IN #20345 BELLCRANK)
16	20373	0		LINK-IDLER ARM LT
17	9340	0		PIN-CLEVIS .375X.719 (TAKES COTTER PIN)
18	20351	0		BRKT-IDLER SUPPORT
19	9704	0	F	SCR-HH 5/16-18X1.0 G5 ZP
20	9912	0		WASHER-LK .312 ZP
21	9900	0		WASHER-FLAT 1/4 SAE
22	20371	0		ARM-IDLER FWD WELD
23	9807	0		NUT-H/LK 3/8-16
24	1113-1	0	S/F	BUSHING-.5X.375X.3
25	9193	0		PULLEY-FWD IDLER
26	9802	0		NUT-HEX 3/8-16 ZP
27	1122	0		SPRING-.406 X 3.125
28	20374	0		LINK-IDLER ARM RT
29	20372	0		ARM-IDLER REV WELD
30	9179	0		PULLEY-REV IDLER
31	9713	0		BOLT-HH 3/8-16X1.5 FTH ZP

20459 PONY I 5HP STD (S/N P1001-P101750)
HANDLE BARS & CONTROL LEVERS

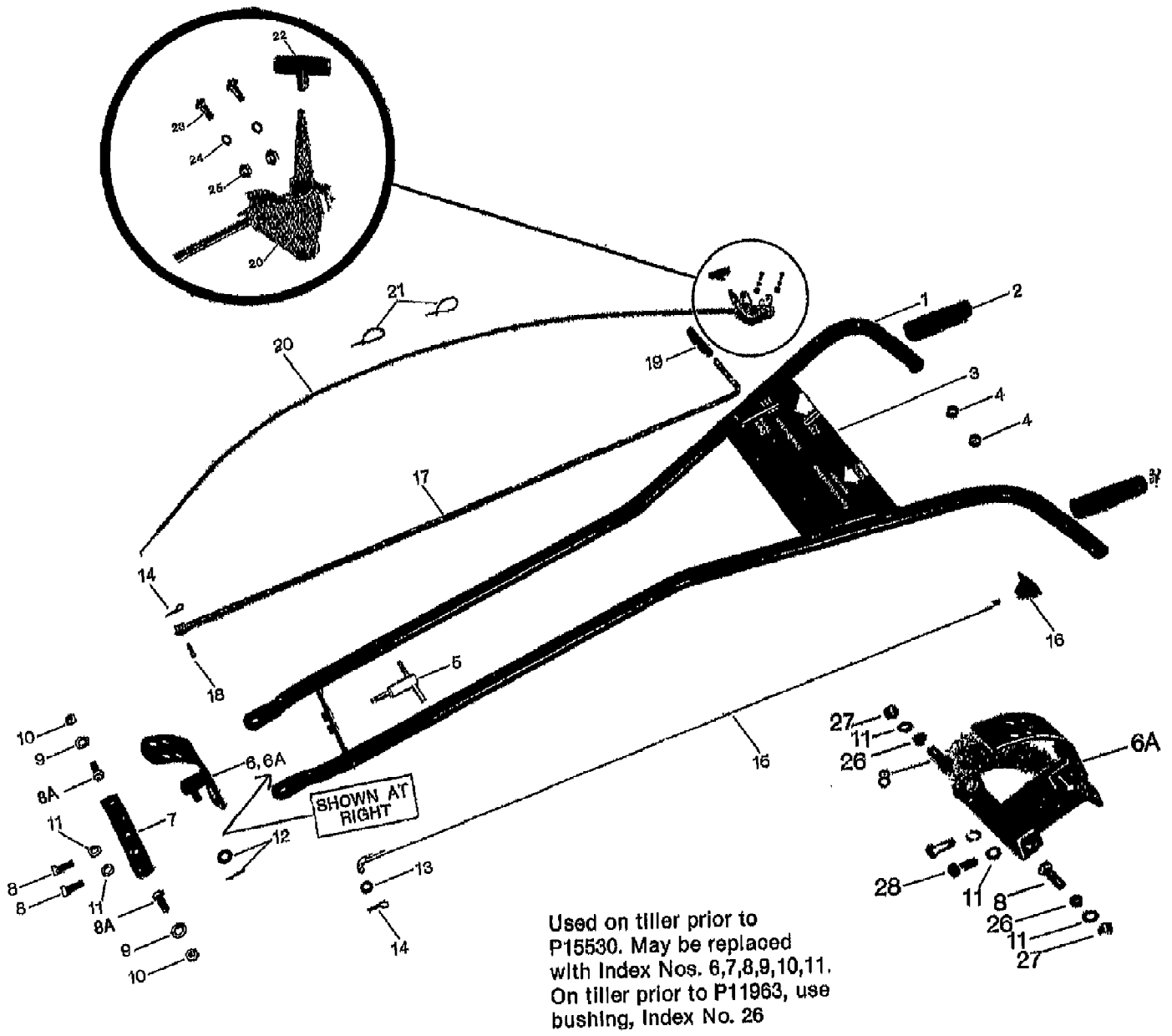

20459 PONY I 5HP STD (S/N P1001-P101750)
HANDLE BARS & CONTROL LEVERS

Page 6 of 16

Ref #	Part Number	Qty	S/P/F	Description
1	20356	0		ASSM-HANDLEBAR
2	9117	0		GRIP-HANDLEBAR
3	20399	0		DECAL-CONTROL PANEL
4	9211	0		GROMMET-PLASTIC
5	20396	0		ASSM-CLAMP
6	20349	0		BRKT-HANDLEBAR MTG WELD
6A	20349	0		BRKT-HANDLEBAR MTG WELD
7	20349-03	0		BRKT-HANDLEBAR MTG
8	9710	0		SCR-HH 3/8-16X1.0 G5 ZP
8A	9711	0		SCR-HH 3/8-16X1.0 G5 ZP
9	9904	0	S	WASHER-FLAT 3/8 SAE
10	9807	0		NUT-H/LK 3/8-16
11	9913	0		WASHER-LK .375 @ DEPL
12	0	0		WASHER & COTTER PIN - FOR IDLER ASSM. CLUTCH LEVER
13	9902	0		WASHER-FLAT 5/16 SAE
14	9338	0	S	PIN-CLIP .08
15	20341	0		ASSM-DRIVE CONTROL ROD
16	9208	0		KNOB-DRIVE CNTRL ROD
17	20343	0		ROD-CONTROL
18	9336	0	S	PIN-CLEVIS .183X1.0 ZP
19	9198	0		GRIP-CONTROL ROD
20	9191	0	F	CABLE-THROTTLE (COMPLETE)
21	9202	0	S	TIE-RED
22	9212	0	S	KNOB-THROTTLE CABLE
23	9722	0		SCR-RH M10-32X.5 MACH
24	9909	0		WASHER-LK M10
25	9809	0		NUT-HH M10-32X.125
26	1113-1	0	S	BUSHING-.5X.375X.3 (REPLACES 1113)
27	9802	0		NUT-HEX 3/8-16 ZP
28	9712	0		SCR-HH 3/8-16X1.25

20459 PONY I 5HP STD (S/N P1001-P101750)
HOOD & DEPTH REGULATOR

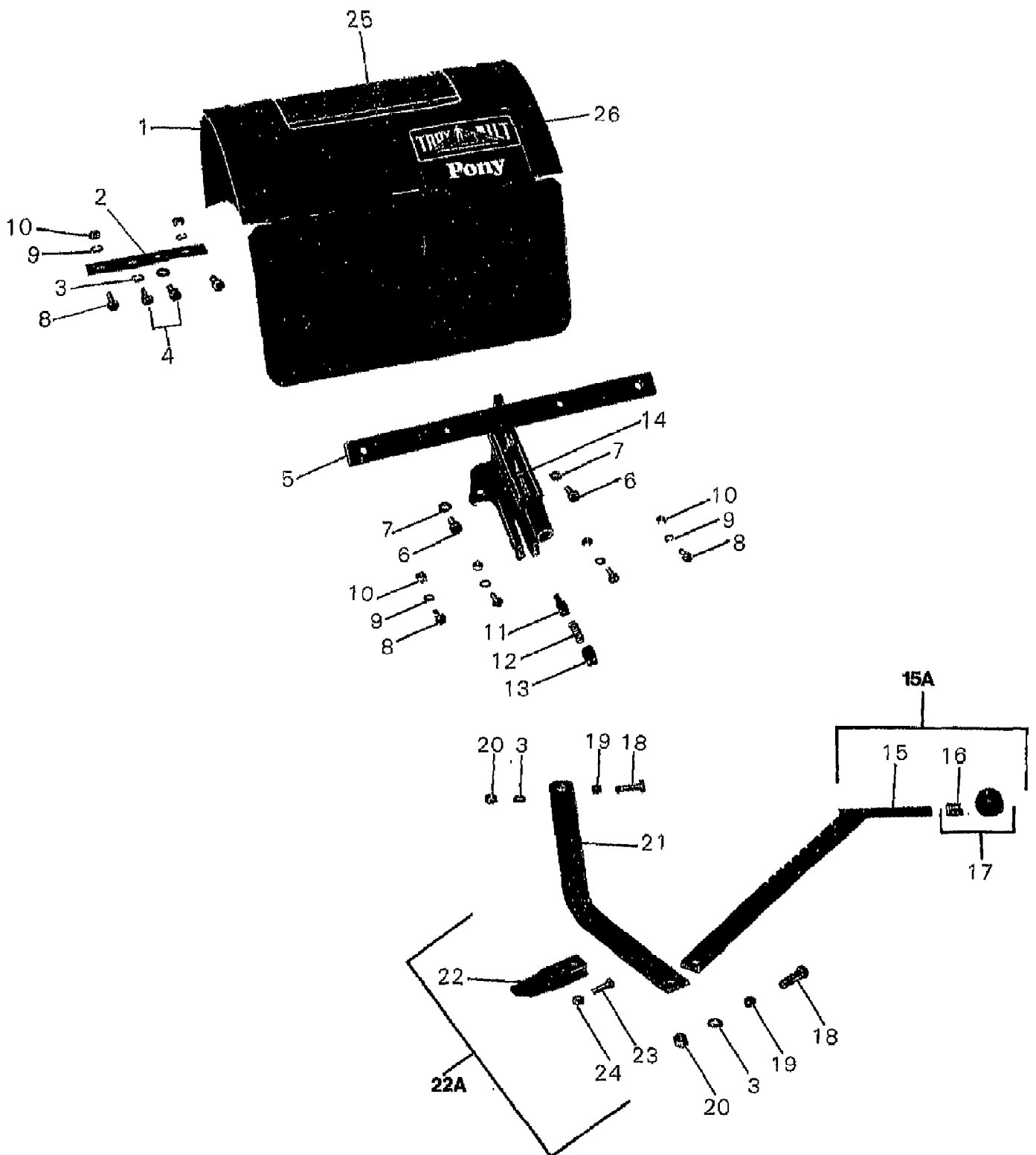

20459 PONY I 5HP STD (S/N P1001-P101750)
HOOD & DEPTH REGULATOR

Page 8 of 16

Ref #	Part Number	Qty	S/P/F	Description
1	20449	0		HOOD W/DECAL-PONY 2 (INCL. 25 & 26)
1	20489	0	F	HOOD W/DECAL-PONY 2 (INCL. 25 & 26)
1	20635	0	F	HOOD W/DECALS (INCL. 25 & 26)
2	20397	0		PLATE-HOOD MTG (REPLACES SHORTER VERSION USED ON P14465 & EARLIER)
3	9913	0		WASHER-LK .375 @ DEPL
4	9710	0		SCR-HH 3/8-16X1.0 G5 ZP
5	20368	0		KIT-REAR HOOD BRKT PONY
6	9703	0		SCR-HHC 5/16-18X.75 GR 5 (BRACKET TO REAR BEARING CAP)
7	9912	0		WASHER-LK .312 ZP
8	9723	0		SCR-RH 1/4-20 X .75 (HOOD TO BRACKET)
9	9910	0		WASHER-LK .25 ZP
10	9800	0		NUT-HEX 1/4-20 ZP
11	1119	0		PLUNGER
12	1120	0		SPRING .406 X 1.25
13	9726	0	S	PLUG-PIPE 1/4 NPT
14	9308	0	S	PIN-ROLL .25 X 1 (SPIRAL)
15A	1117A	0	S	DEPTH REGULATOR W/KNOB (INCL. 15-17)
15	0	0		BAR - DEPTH ADJUSTMENT (NOT AVAIL. SEP.)
16	9120	0	S	RING-TOLERANCE .5325 ID
17	9119	0	S	KNOB-CONTROL (INCL. RETAINING RING, #16)
18	9712	0		SCR-HH 3/8-16X1.25
19	1113-1	0	S	BUSHING-.5X.375X.3 (REPLACES 1113)
20	9802	0		NUT-HEX 3/8-16 ZP
21	20358	0		BAR-DRAG
22A	1307	0	F	SOD POINT ASSY - COMPLETE (INCL. #9811 LOCKNUT, #9701 BOLT, #1294 SOD POINT)
22	0	0	F	SOD POINT
23	9701	0		SCR-HH 1/4-20X.75 G5 ZP
24	9811	0		NUT-LK 1/4-20
25	20400	0		DECAL-HOOD TILLER OPERATION INSTRUCTIONS
26	20401	0		DECAL-HOOD LOGO PONY OPC (MODEL NAME DECAL)

20459 PONY I 5HP STD (S/N P1001-P101750)
MAIN DRIVE SHAFT & GEAR ASSEMBLIES

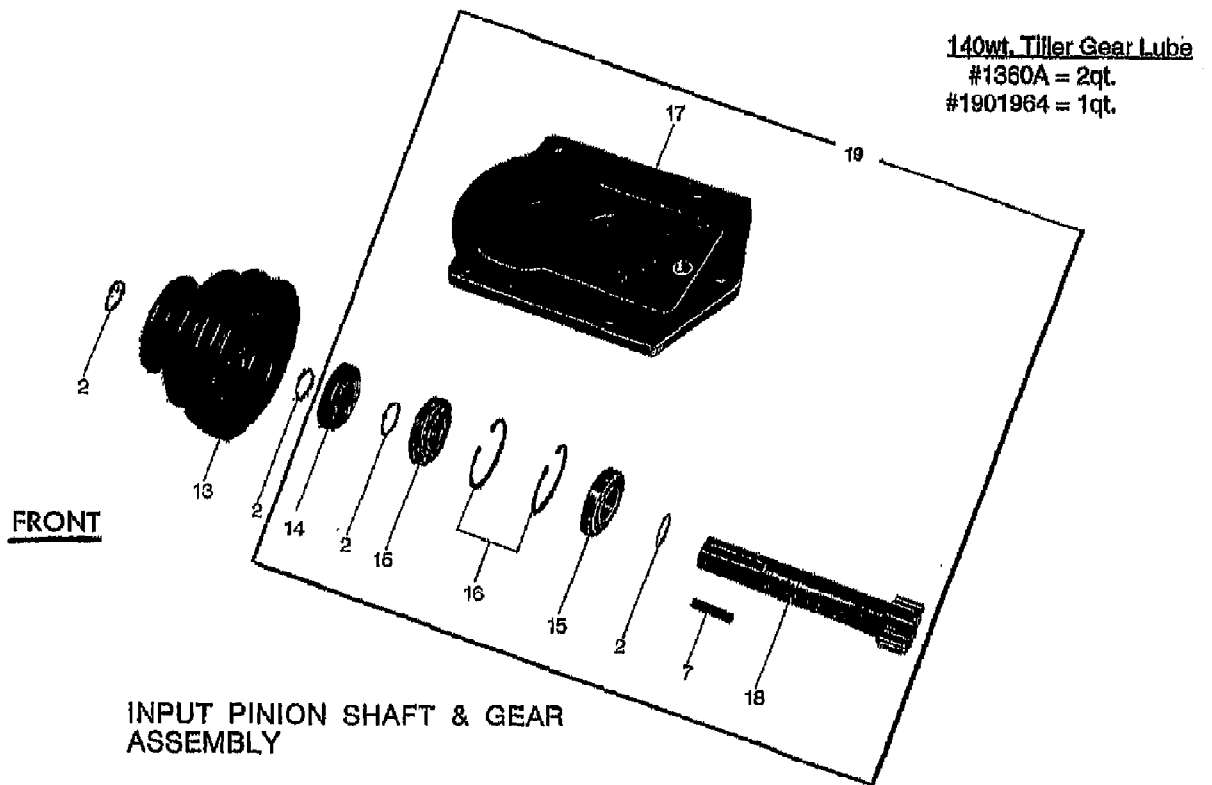
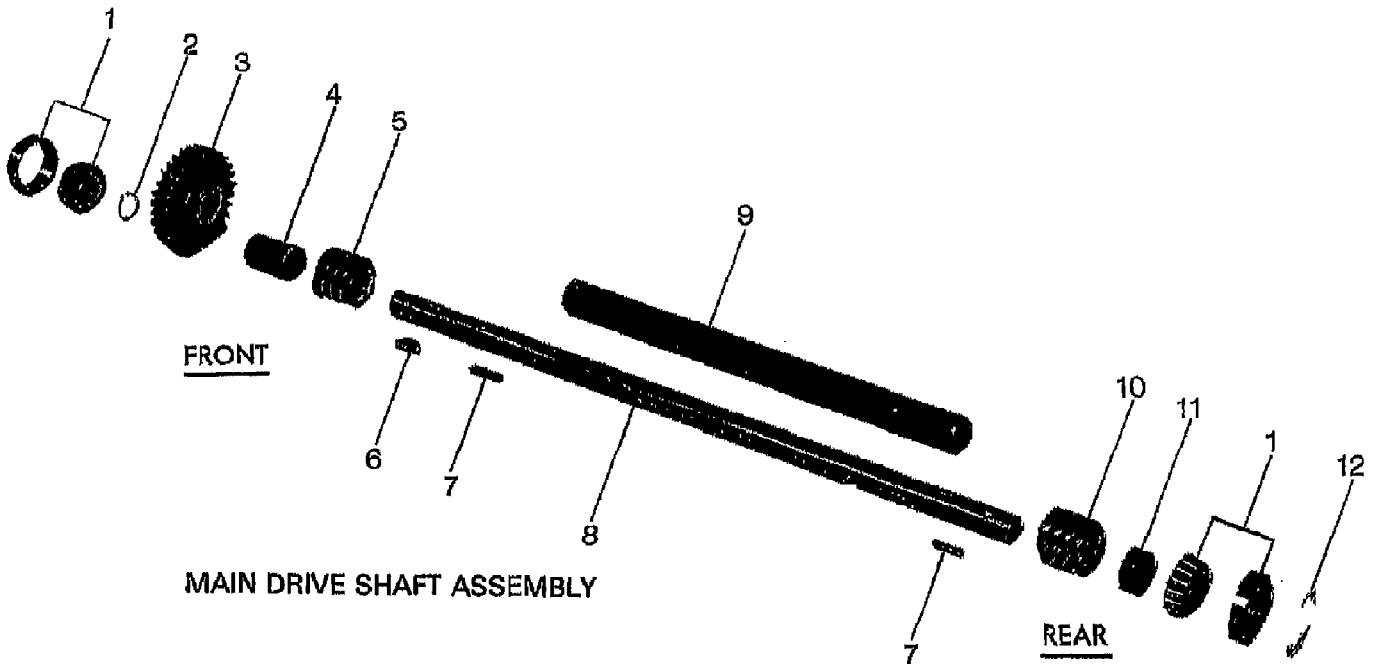

20459 PONY I 5HP STD (S/N P1001-P101750)
MAIN DRIVE SHAFT & GEAR ASSEMBLIES

Page 10 of 16

Ref #	Part Number	Qty	S/P/F	Description
1	1714	0	S	KIT-BRG CONE&RACE-DRIVESHAFT
2	9500	0	S	RING-RETAIN EXT .707 ID
3	20310	0		GEAR-SPUR 30 TEETH
4	20323	0		SPACER-1X.76X1.25
5	20307	0		WORM-1.25 PD .314 LEAD
6	9335	0		KEY-WOODRUFF #607
7	9301	0	S	KEY-.188 SQX1.0
8	20314	0		SHAFT-DRIVE MACH
9	20324	0		TUBING-MACH
10	20305	0		WORM-1.25 PD 1.88 LEAD
11	1066	0		SPACER-1X.76X.54
12	1224-1	0	S/F	SHIM-REAR BEARING CAP - 1.75X1.5X.01
12	1224-2	0	S/F	SHIM-REAR BEARING CAP -1.75X1.5X.03
12	1224-3	0	S/F	SHIM-REAR BEARING CAP -1.75X1.5X.005
	1325C	0	S	SHIM SET-DRIVESHAFT-HORSE (INCL. #1224-1 (2) , #1224-2(2), #1224-3(1) SHIMS.
19	1883	0	F	COVER-TRANS W/BRG CONE, INCL. 2, 14-18
2	9500	0	S	RING-RETAIN EXT .707 ID
7	9301	0	S	KEY-.188 SQX1.0
13	20315	0		PULLEY-DRIVE MACH
14	9610	0		SEAL-OIL .75 ID (FORMERLY #611)
15	9416	0		BRG-BALL (10 BALLS)(FORMERLY #436)
16	9509	0		RING-RETAINING (SNAP RING, INTERNAL) (FORMERLY #514)
17	1882	0		OBS-COVER-TRANS W/BRG CUP(INCL. #1 PART #1714)
18	20313	0		GEAR-SPLINE 10 TEETH MACH
	1360A	0		OIL GEAR LUBE 2 QT 140WT
	1901964	0		OIL GEAR LUBE 1 QT 140WT

20459 PONY I 5HP STD (S/N P1001-P101750)
TINES & WHEELS

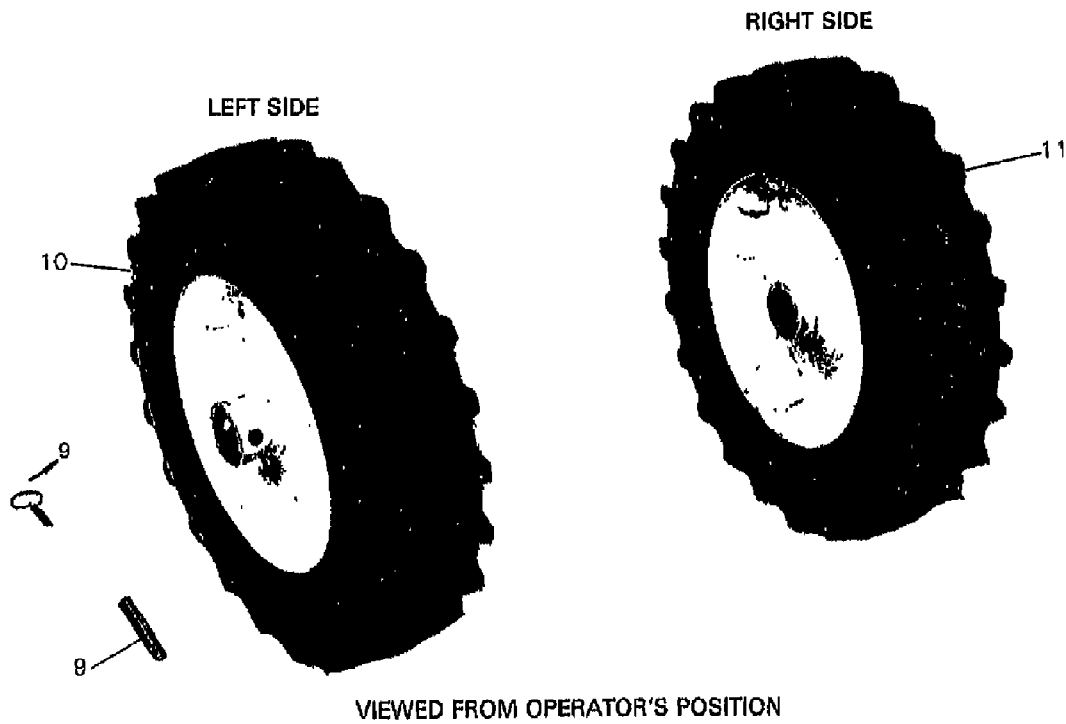
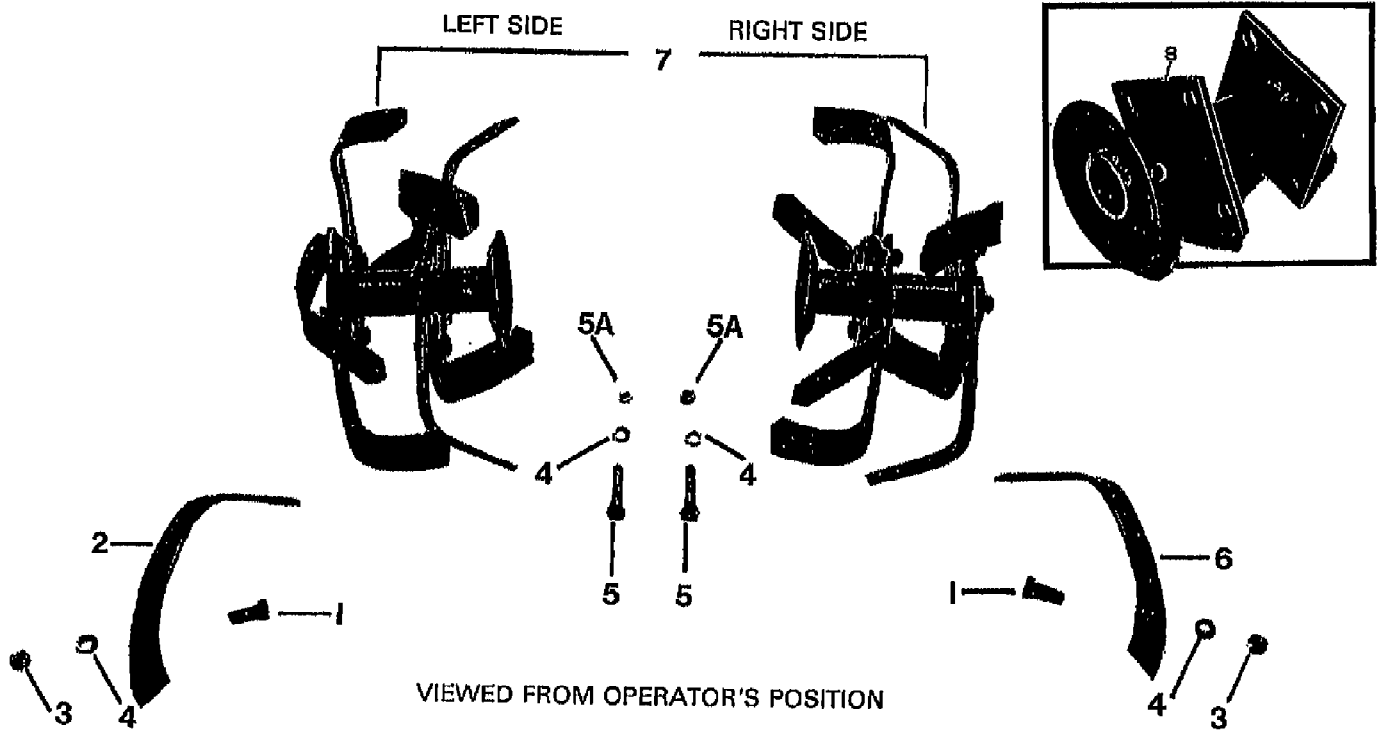

20459 PONY I 5HP STD (S/N P1001-P101750)
TINES & WHEELS

Page 12 of 16

Ref #	Part Number	Qty	S/P/F	Description
1	9711	0		SCR-HH 3/8-16X1.0 G5 ZP
2	1270-2A	0	S	TINE-BOLO RT W/HDW
3	9802	0		NUT-HEX 3/8-16 ZP
4	9913	0		WASHER-LK .375 @ DEPL
5	9761	0		SCR-HH 3/8-16X2.00 G8 (HOLDER TO TILLER SHAFT)
5A	9807	0		NUT-H/LK 3/8-16
6	1270-1A	0	S	TINE-BOLO LT W/HDW
7	1347	0	F	PONY TINES W/HLDRS
7	1876	0	F	P-1 BOLO&HOLDS
8	20353	0		WELD-TINE HOLDER
8	20480	0		T HOLDER
	1348	0	F	TINES-BOLO HORSE/PONY/ECONO REPLACEMENT
9	9322	0	S	PIN-SPIRAL .313 X 1.5
9	9355	0	F	PIN-QUICK RELEASE
10	20365-01	0	F	ASSM-WHEEL/TIRE LT
11	20365-02	0	F	ASSM-WHEEL/TIRE RT
11	20533-01	0	F	ASSM-TIRE LT 4.10 X 6"
11	20533-02	0	F	ASSM-TIRE RT 4.10 X 6"
11	20479-01	0	F	WHEEL/TIRE-LT PONY 2
11	20479-02	0	F	WHEEL/TIRE-RT PONY 2

20459 PONY I 5HP STD (S/N P1001-P101750)
TRANSMISSION HOUSING & SEALS/GASKET

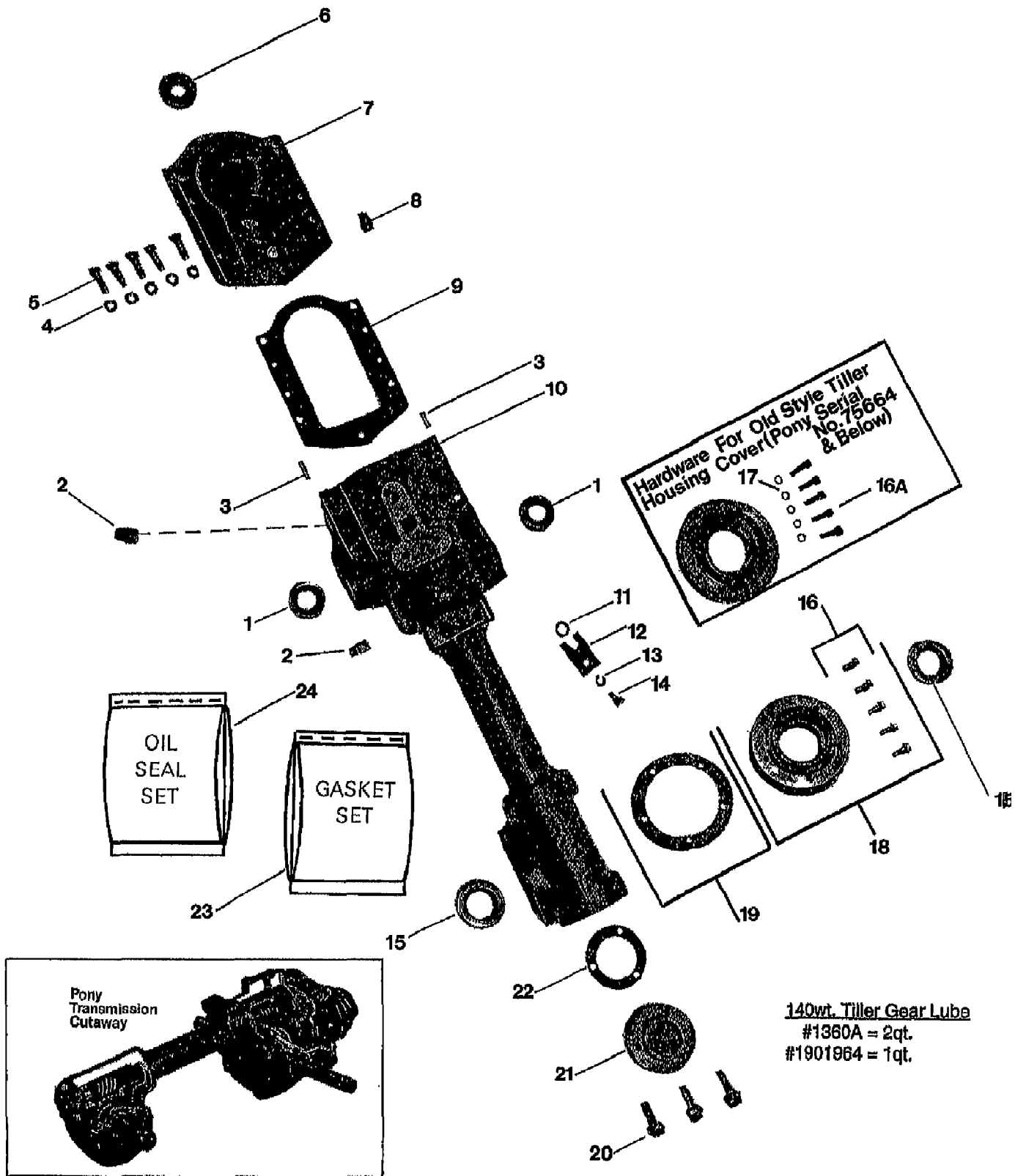

20459 PONY I 5HP STD (S/N P1001-P101750)
TRANSMISSION HOUSING & SEALS/GASKET

Page 14 of 16

Ref #	Part Number	Qty	S/P/F	Description
1	9609	0	F	SEAL-OIL WHEEL SHAFT
2	9727	0	S/F	PLUG-PIPE 3/8"
3	9321	0	F	PIN-DRIVE .25 X .75 (INCL. WITH TRANSMISSION CASE PART NO. 20330)
4	9912	0	F	WASHER-LK .312 ZP
5	9704	0	F	SCR-HH 5/16-18X1.0 G5 ZP
6	9610	0	F	SEAL-OIL .75 ID (INSTALLS IN COVER)(FORMERLY #611)
7	20301	0	F	COVER-TRANS MACH
8	9726	0	S/F	PLUG-PIPE 1/4 NPT
9	20338	0	F	GASKET-TRANS COVER
10	20330	0	F	CASE-TRANS (WITHOUT COVERS, SHAFTS, GEARS. CALL FACTORY FOR SERVICE HELP)
11	9603	0	F	RING-O .625 X .438 (SEE PAGE 16, INDEX 13)
12	20325	0	F	PLATE-FRICTION (SEE PAGE 16, INDEX 17)
13	9910	0	F	WASHER-LK .25 ZP (SEE PAGE 16, INDEX 19)
14	9743	0	F	SCR-HH 1/4-20X.5 GR5 YEL
15	9602	0	F	SEAL-OIL TILLERSHAFT
16	9780	0	F	SCR-HH 1/4-20X.625
16A	9718	0	F	SCR-HXSKT 1/4-20X.625
17	9911	0	S/F	WASHER-LK .25 HI-COLLAR
18	1872	0	F	COVER-W/SCR(S)(TLR) (9780)
19	1129-1	0	S/F	GASKET-TILLER COVER (AR)
19	1129-2	0	S/F	GASKET-TILLER COVER (AR)
20	9773	0	F	SCR-HFLK 1/4-20X.875
21	1115	0	F	CAP-REAR #1115
22	1124-2	0	S/F	GASKET-BRG COVER (AR)
23	1345	0	F	TRANS GASKET SET-PONY (AR)
24	1346A	0	F	OIL SEAL SET-PONY (AR)
	1360A	0		OIL GEAR LUBE 2 QT 140WT
	1901964	0		OIL GEAR LUBE 1 QT 140WT

20459 PONY I 5HP STD (S/N P1001-P101750)
WHEEL & TILLER SHAFT ASSEMBLIES

ATTENTION

NOTE: FOR PONY II
S/N's P88132 - P95831 ONLY
REFER TO GRID B-5 FOR
APPROPRIATE WHEEL SHAFT ASSY PARTS

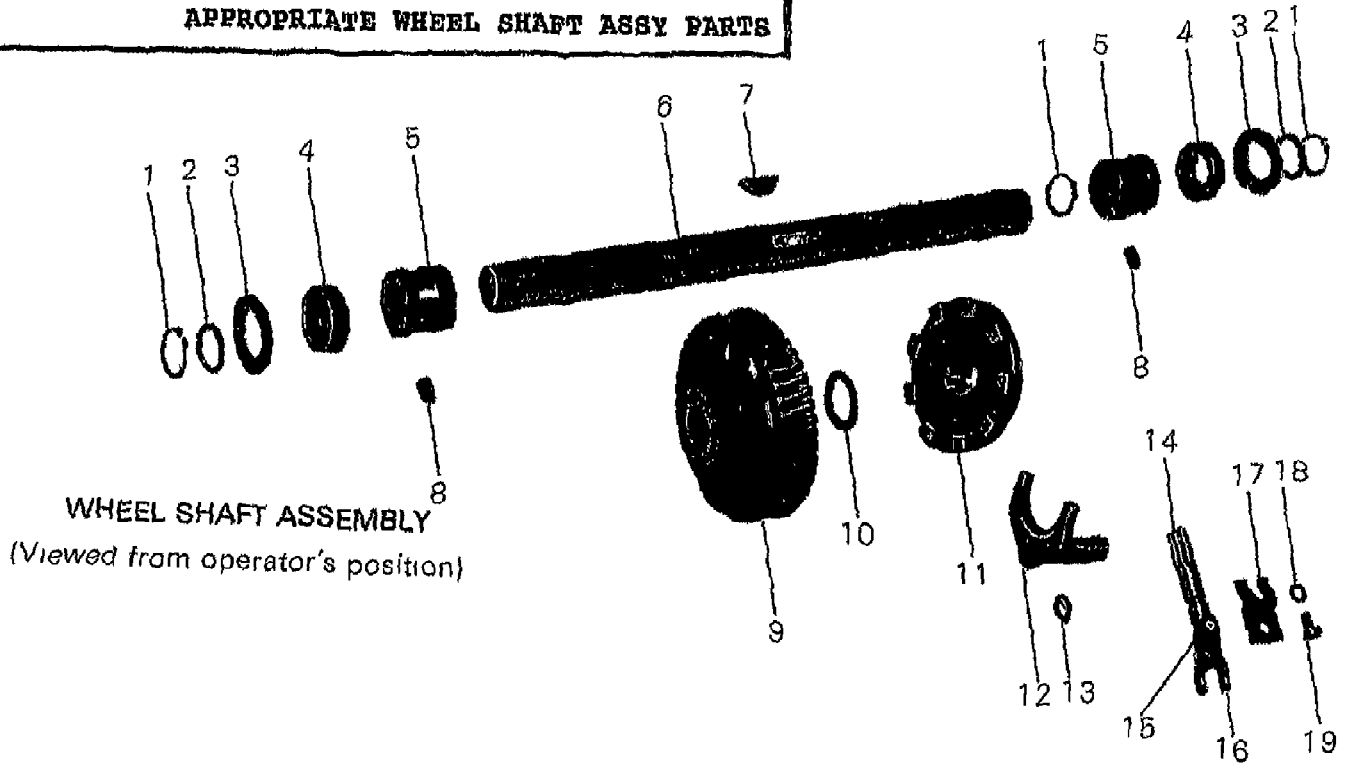

140wt. Tiller Gear Lube
#1380A = 2qt.
#1301964 = 1qt.

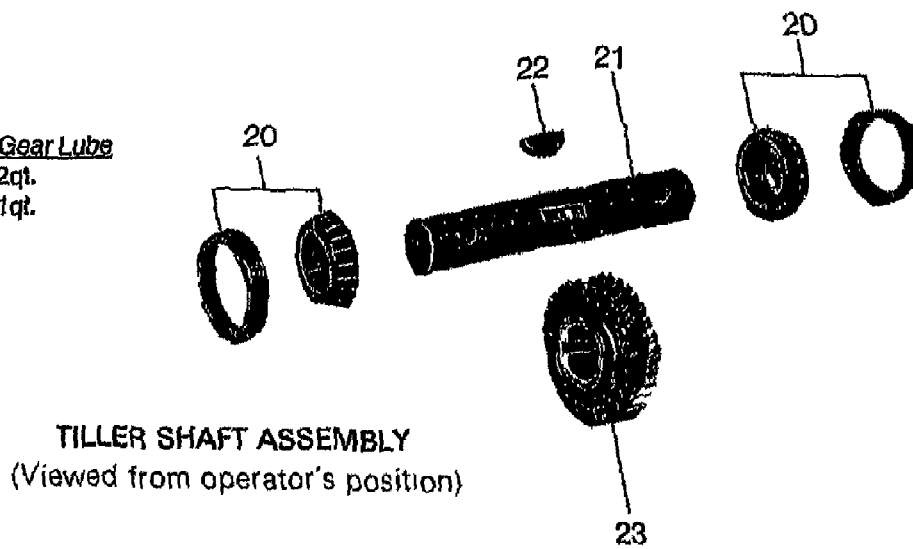

20459 PONY I 5HP STD (S/N P1001-P101750)
WHEEL & TILLER SHAFT ASSEMBLIES

Page 16 of 16

Ref #	Part Number	Qty	S/P/F	Description
1	9501	0		RING-RETAINING 5100-100
2	1324B	0	F	SHIM SET-WHEELSHAFT-HORSE
2	1166-2	0	S	SHIM-1.375X1.015X.03
2	1166-3	0	S	SHIM-1.375X1.015X.015
2	1166-4	0	S	SHIM-1.375X1.015X.01
3	20326	0		SHIM-1.75X1.013X.09
4	9609	0		SEAL-OIL WHEELSHAFT
5	20311	0		BUSHING-1.503X1.005X1.187
6	20436	0		ASSM-WHEELSHAFT W/KEY (REPLACES # 20322)
7	9305	0	S	KEY-HI PRO .25X1.062
8	9755	0		SCR-SS 3/8-16 X .5 (CP)
9	20308	0		GEAR-WORM
10	1166-1	0	S	SHIM-1.375X1.015X.062
11	20304	0		CLUTCH-MACH
12	20318	0		YOKE-RIVETED HT
13	9603	0		RING-O .625 X .438
14	20321	0	F	SPLINE/YOKE-HT
15	9339	0	F	PIN-SPIROL .188 X .875
16	20350	0	F	UNIVERSAL (U-JOINT)
17	20325	0		PLATE-FRICTION
18	9910	0		WASHER-LK .25 ZP
19	9743	0		SCR-HH 1/4-20X.5 GR5 YEL
20	1715	0	F	BRG & RACE
	11514	0		KIT-TILLER GEAR PONY 1-4
21	20437	0		ASSM-TILLERSHAFT W/KEY (REPLACES #20335)
22	1104	0	S	KEY-WOODRUFF .25X1.12
23	20306	0		KIT-TILLER GEAR PONY 1-4
	1360A	0		OIL (1901964)
	1901964	0		OIL-GEAR 1 QT 140WT