

25B-554F266 (2007)
General Assembly

Page 1 of 3

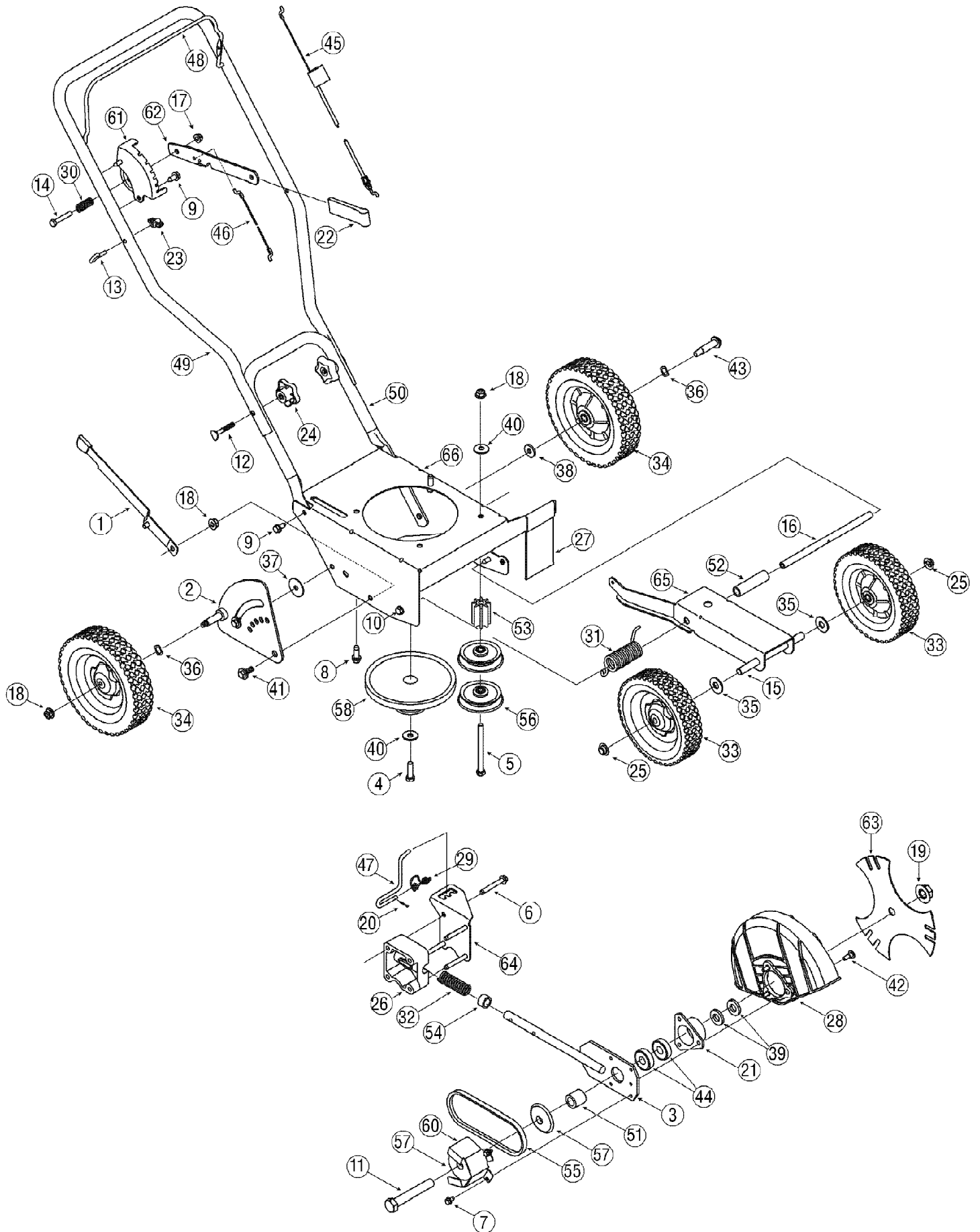

25B-554F266 (2007)
General Assembly

Page 2 of 3

Ref #	Part Number	Qty	S/P/F	Description
1	687-02022	1		Curb Height Adjustment Lever
2	687-02125A	1		Curb Height Adjuster Plate
3	687-02126	1		Blade Plate Assembly
4	710-0191	1	/P	Screw 3/8-24
5	710-0411	1	/P	Screw 3/8-16
6	710-04389	1		Hex Screw, 5/16-18
7	710-0599	1	/P	Self-tapping Screw, 1/4-20
8	710-0654A	1	/P	Screw, 3/8-16
9	710-0726	1	/P	Hex Screw, 5/16-12
10	710-0870	1	/P	Hex Screw 5/16-18
11	710-1143A	1	/P	Hex Screw, 5/8-18
12	710-1174	1	/P	Carriage Bolt, 5/16-18
13	710-1205	1	/P	Rope Guide (Eye Bolt)
14	710-3180	1	/P	Hex Screw, 5/16-18
15	711-04361	1		Axle Shaft .50x6.65
16	711-04440	1		Frame Spacer .50x9.25
17	712-04063	1	/P	Lock Flange Nut, 5/16-18
18	712-04065	1	/P	Flange Nut 3/8-16
19	712-0417A	1	/P	Flange Nut, 5/8-18
20	714-3010	1	/P	Clevis Pin 3/32 x .625
21	718-04012	1	/P	Bearing Cup
22	720-0142	1	/P	Grip
23	720-0279	1	/P	Wing Nut
24	720-04072	1	S	Star Knob
25	726-0299	1	/P	Push Cap 1/2" rod
26	731-04207	1	S	Bearing Block
27	731-05063	1		Debris Guard
28	731-05064	1	/P	Blade Guard
29	732-0188A	1	/P	Double Torsion Spring
30	732-0369	1	S	Compression Spring
31	732-04045	1		Torsion Spring
32	732-04169	1	S	Compression Spring
33	734-1264	1	/P	Wheel 7 x 1.75 T-Tread Optional
34	734-1268	1	/P	Wheel 8 x 1.75 T-Tread Optional
35	736-0179	1	S	Flat Washer 1/2 x 1.25 x .10 Optional
36	736-0232	1	S	Wave Washer .531 x .781 x .013
37	736-0234	1	/P	Flat Washer, .385 x 1.5 x .075
38	736-0258	1	/P	Flat Washer .385 x 1.0 x .135 Optional
39	736-04088	1	S	Flat Washer .635x1.24x.181
40	736-0452	1	S	Bell Washer,.396 x 1.140
41	738-04149	1		Shoulder Screw, 3/8-16
42	738-0706C	1	/P	Shoulder Screw
43	738-0929	1		Shoulder Screw, 3/8-16
44	741-0524	1	S	Bearing, .625 ID x 1.57 OD
45	746-04035	1		Control Cable (Briggs & Stratton)
46	746-04036	1	S	Wheel Adjustment Cable
47	747-04110	1		Blade Adjustment Rod
48	747-0976A	1	S	Bail Handle
49	749-04183	1	S	Upper Handle
50	749-04234	1	S	Lower Handle
51	750-04105	1	S	Spacer, .63 x 1.12 x 1.06
52	750-04129	1		Spacer
53	750-04142	1	S	Pulley Mount Spacer

25B-554F266 (2007)
General Assembly

Page 3 of 3

Ref #	Part Number	Qty	S/P/F	Description
54	750-0547	1		Spacer, .64 x.88 x .50
55	754-04032B	1	S	Belt
56	756-04148	1		Flat Idler Pulley, 2.5 OD
57	756-0449	1	S	Sheave
58	756-1150A	1		Combination Flywheel Pulley
59	781-0080	1	S	Edger Blade
60	781-0427	1	S	Belt Guard
61	781-0741A	1		Depth Index Bracket
62	781-0742	1	S	Depth Index Lever
63	781-0748	1	S	Tri-Star Blade (Trencher) Optional
64	787-01081A	1		Cover Plate
65	787-01239	1		Dual Wheel Bracket
66	787-01304	1		Frame