

TECUMSEH

TECHNICIAN'S HANDBOOK

This manual covers the following models:
VH80, VH100, HH80, HH100, HH120, OH120-180
Model numbers are located on the engine shroud.

Other illustrated Tecumseh 2-Cycle Engine, 4-Cycle Engine
and Transmission manuals; booklets; and wall charts are
available through Tecumseh.

For complete listing write or call

**8 TO 18 HP
CAST IRON
FOUR CYCLE
ENGINES**



Contents

	Page
CHAPTER 1. GENERAL INFORMATION	1
SECTION 1. ENGINE IDENTIFICATION	1
SECTION 2. ENGINE CARE	2
CHAPTER 2. AIR CLEANERS, CARBURETORS, GOVERNORS AND LINKAGE	4
SECTION 1. AIR CLEANERS	4
SECTION 2. GENERAL CARBURETOR INFORMATION	5
SECTION 3. TECUMSEH CARBURETORS	6
SECTION 4. WALBRO CARBURETORS	10
HH80 - 120, VH80 - 100	10
SECTION 5. OVERHEAD VALVE ENGINE CARBURETORS	13
SECTION 6. GOVERNORS	16
SECTION 7. IMPULSE FUEL PUMP	19
CHAPTER 3. REWIND STARTERS, ELECTRIC STARTERS, TROUBLESHOOTING AND GENERATORS	20
SECTION 1. REWIND STARTERS	20
SECTION 2. ELECTRIC STARTERS	22
SECTION 3. 12 VOLT STARTER TROUBLE SHOOTING CHART	25
CHAPTER 4. GENERAL VALVE INFORMATION, CYLINDER HEAD AND BREATHER ASSEMBLY	27
SECTION 1. GENERAL VALVE INFORMATION	27
SECTION 2. CYLINDER HEAD	31
SECTION 3. BREATHER ASSEMBLIES	32
CHAPTER 5. PISTON AND RINGS, CONNECTING RODS AND CRANKSHAFTS	33
SECTION 1. PISTON AND RINGS	33
SECTION 2. CONNECTING RODS	35
SECTION 3. CRANKSHAFTS	36
CHAPTER 6. CAMSHAFT, BEARINGS AND SEALS	37
SECTION 1. CAMSHAFT	37
SECTION 2. BEARINGS	38
SECTION 3. SEALS	42
CHAPTER 7. DYNA-STATIC® BALANCING SYSTEM	43
CHAPTER 8. IGNITION SYSTEMS, CHARGING SYSTEMS BATTERY SERVICE and ELECTRICAL CONTROL PANELS	45
SECTION 1. IGNITION SYSTEMS	45
SECTION 2. CHARGING SYSTEMS	48
SECTION 3. BATTERY SERVICE	53
SECTION 4. ELECTRICAL CONTROL PANELS	56
CHAPTER 9. TROUBLESHOOTING	61
CHAPTER 10. 8 H.P. & LARGER ENGINE SPECIFICATIONS AND TORQUES	66
SECTION 1. CROSS REFERENCE LIST FOR TABLE OF SPECIFICATIONS	66
SECTION 2. TORQUE SPECIFICATIONS	70
8 H.P. & LARGER ENGINES (EXCEPT VALVE-IN-HEAD)	70
SECTION 3. VALVE-IN-HEAD ENGINE SPECIFICATIONS	71
SECTION 4. TORQUE SPECIFICATIONS	73
VALVE-IN-HEAD	73
CHAPTER 11. EDUCATIONAL MATERIALS AND TOOLS	74

CHAPTER 1. GENERAL INFORMATION

SECTION 1. ENGINE IDENTIFICATION

Tecumseh engine model numbers are stamped into the blower housing, or are located on a nameplate or tag on the engine in locations as illustrated.

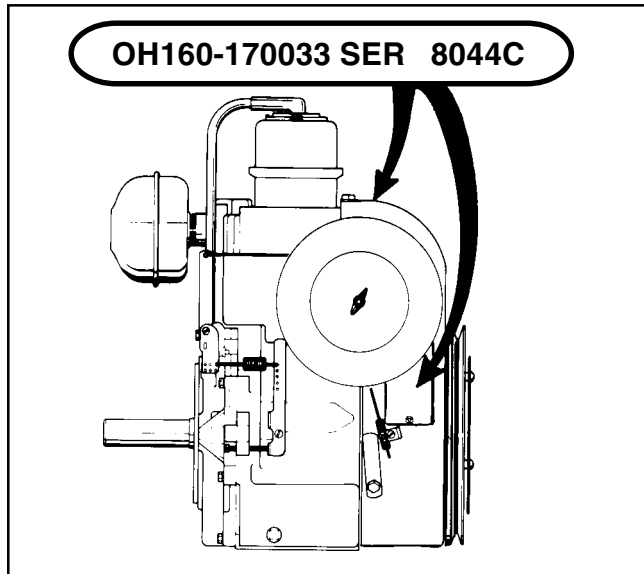

SHORT BLOCKS. New short blocks are identified by a tag marked SBH (Short Block Horizontal) or SBV (Short Block Vertical). Original model tags of engines should always be transferred to a short block for correct parts identification.

INTERPRETATION OF MODEL NUMBER. The first letter designations in a model number indicate the basic type of engine.

HH - Horizontal-Heavy Duty (Cast Iron)
VH - Vertical-Heavy Duty (Cast Iron)
OH - Overhead Valve-Heavy Duty (Cast Iron)

The number designations following the letter indicates the horsepower of the engine.

The number following the model number is the specification number. The last three numbers of the specification number indicate a variation to the basic engine specification.

The serial number indicates the production data.

Using model number OH160-170033, Serial 8044C as an example, interpretation is as follows:

OH160-170033 - is the model and specification number.
OH - Overhead Valve-Heavy Duty (Cast Iron)
160 - Indicates 16 horsepower.
170033 - is the specification number used for properly identifying the parts of the engine.
8044C - is the serial number.
8 - first digit is the year of manufacture (1998)
044 - indicates calendar day of that year (044 day or February 13, 1998).
C - represents the line, shift or plant in which the engine was built at the factory.

SECTION 2. ENGINE CARE

FUELS. Use clean, fresh unleaded automotive gasoline in all Tecumseh four-cycle engines. (Leaded "regular" gasoline is an acceptable substitute.)

NOTE: Do Not use gasoline containing methanol (wood alcohol). Gasoline containing a maximum of 10 ethanol or grain alcohol (sometimes called "gasohol") may be used but requires special care when engine is unused for extended periods. See "STORAGE" instructions.

ENGINE OIL, ALL FOUR CYCLE ENGINES:

USE A CLEAN, HIGH QUALITY, DETERGENT OIL. Be sure original container is marked with engine service classification "SF - SJ."

DO NOT USE SAE10W40 OIL.

FOR SUMMER (ABOVE 32°F, 0°C) USE SAE 30 OIL (SAE10W30 is an acceptable substitute.)

FOR WINTER (BELOW 32°F, 0°C) USE SAE 5W20 OR 5W30 OIL. (SAE10W is an acceptable substitute.)

(BELOW 0°F, -18°C ONLY) Use 0W30 oil or SAE10W oil diluted with 10% kerosene is acceptable.

NOTE: For severe, prolonged, winter operation of HH120 model, SAE10W oil is recommended.

OIL CHANGE INTERVALS. Change oil after first two (2) hours of operation and every 25 hours thereafter, or more often if operated under dusty or dirty conditions.

OIL CHECK. Check oil every 5 hours or each time the equipment is used. Position equipment so the engine is level when checking the oil.

BREAK-IN PROCEDURE. Proper break-in procedure is important for proper seating of rings, on a new engine or newly overhauled engine.

Do normal work with the unit, running the engine under load. Vary the load on the engine frequently to aid in seating of the rings.

The engine should not be allowed to idle or run at part throttle for extended periods during break-in. Work the engine but do not abuse it.

TUNE-UP PROCEDURE. The following is a minor tune-up procedure. When this procedure is completed, the engine will operate properly or you may discover that further repairs may have to be performed.

NOTE: It is recommended to use only factory parts in a Tecumseh engine. This is especially important with an air filter, since the use of any other than the specified part number may result in serious damage to the engine.

CAUTION: Remove spark plug wire before doing any service work on engine.

1. Service or replace air cleaner as necessary.
2. Inspect level and condition of oil; drain oil.
3. Remove blower housing, clean all dirt, grass or debris from intake screen, head and cylinder cooling fins and carburetor governor levers and linkage.
4. Remove cylinder head, remove carbon, inspect valves and cylinder bore. Replace head using a new head gasket. Torque to specifications.
5. Remove carburetor, clean and install carburetor kit, make adjustment pre-sets where needed. Make sure fuel tank, fuel filters and fuel lines are clean. Reinstall carburetor, replacing any worn or damaged governor springs or linkage. Make proper governor adjustment.
6. Remove flywheel, check for leaks in oil seals, check flywheel key and reinstall flywheel. Replace spark plug and check for spark.
7. Make sure all remote linkage is properly adjusted for proper operation.
8. Replace fuel and oil.
9. Run engine and adjust carburetor and set R.P.M. to specifications found on Microfiche or computer parts lookup.

STORAGE: (IF THE ENGINE IS TO BE UNUSED FOR 30 DAYS OR MORE)



CAUTION: NEVER STORE THE ENGINE WITH FUEL IN THE TANK INDOORS, IN ENCLOSED POORLY VENTILATED AREAS WHERE FUEL FUMES MAY REACH AN OPEN FLAME, SPARK OR PILOT LIGHT AS ON A FURNACE, WATER HEATER, CLOTHES DRYER OR OTHER GAS APPLIANCE.

Gasoline can become unstable in less than 30 days and form deposits that can impede proper fuel flow and engine operation. To prevent deposits from forming, all gasoline must be removed from the fuel tank and the carburetor. An acceptable alternative to removing all gasoline is adding a fuel stabilizer to the gasoline. Fuel stabilizer (such as Tecumseh's **Part No. 730245**) is added to the fuel tank or storage container. Always follow the mix ratio found on the stabilizer container. Run the engine at least 10 minutes after adding the stabilizer to allow it to reach the carburetor.

DRAINING THE FUEL SYSTEM:



CAUTION: DRAIN THE FUEL INTO AN APPROVED CONTAINER OUTDOORS, AND AWAY FROM ANY OPEN FLAME OR COMBUSTION SOURCE. BE SURE THE ENGINE IS COOL.

1. Remove all gasoline from the fuel tank by running the engine until the engine stops, or by draining the fuel tank by removing the fuel line at the carburetor or fuel tank. Be careful not to damage the fuel line, fittings, or fuel tank.
2. Drain the carburetor by pressing upward on the bowl drain (if equipped) which is located on the bottom of the carburetor bowl. On carburetors without a bowl drain, the carburetor may be drained by loosening the bowl nut on the bottom carburetor one full turn. Allow to completely drain and retighten the bowl nut being careful not to damage the bowl gasket when tightening.
3. If "Gasohol" has been used, complete the above procedure and then put one half pint of unleaded gasoline into the fuel tank and repeat the above procedure. If Gasohol is allowed to remain in the fuel system during storage, the alcohol content will cause rubber gaskets and seals to deteriorate.

Change Oil: If the oil has not been changed recently, this is a good time to do it.

Oil Cylinder Bore:

1. Disconnect the spark plug wire and ground the wire to the engine. Remove the spark plug and put 1/2 ounce (14 ml) of clean engine oil into the spark plug hole.
2. Cover the spark plug hole with a shop towel.
3. Crank the engine over slowly several times.



CAUTION: AVOID SPRAY FROM SPARK PLUG HOLE WHEN SLOWLY CRANKING ENGINE OVER.

4. Install the spark plug and connect the spark plug wire.

Clean Engine: Remove the blower housing and clean all dirt, grass or debris from the intake screen, cylinder head, cylinder cooling fins, carburetor, governor levers and linkage.

CHAPTER 2. AIR CLEANERS, CARBURETORS, GOVERNORS AND LINKAGE

SECTION 1. AIR CLEANERS

PAPER-TYPE AIR CLEANER SERVICE. Dry type paper air cleaners are utilized on all Tecumseh Large Frame engines. These air cleaners have treated paper elements with rubberlike sealing edges. These edges must seal properly to prevent dirt leakage.

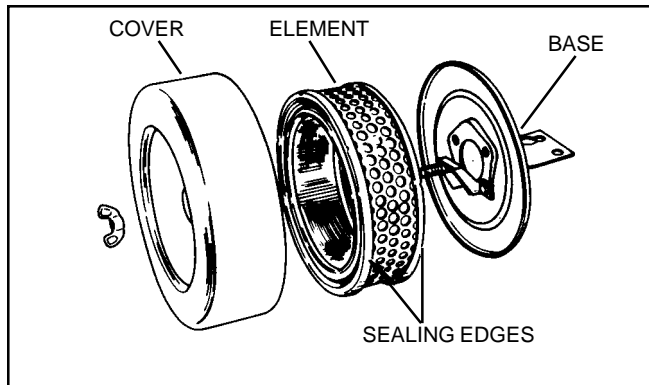

PAPER-TYPE AIR CLEANER SERVICE. Replace air filter once a year or more often in extremely dusty or dirty conditions.

DO NOT ATTEMPT TO CLEAN OR OIL FILTER.

Be sure to clean base and cover thoroughly before installing new paper filter.

NEVER RUN THE ENGINE WITHOUT THE COMPLETE AIR CLEANER INSTALLED ON THE ENGINE.

NOTE: Serious damage to the engine may result in using other than the specified part number filter. Use factory recommended parts only.

POLYURETHANE-TYPE AIR CLEANER. Some Tecumseh Large Frame engines may use a polyurethane air filter in conjunction with a paper filter.

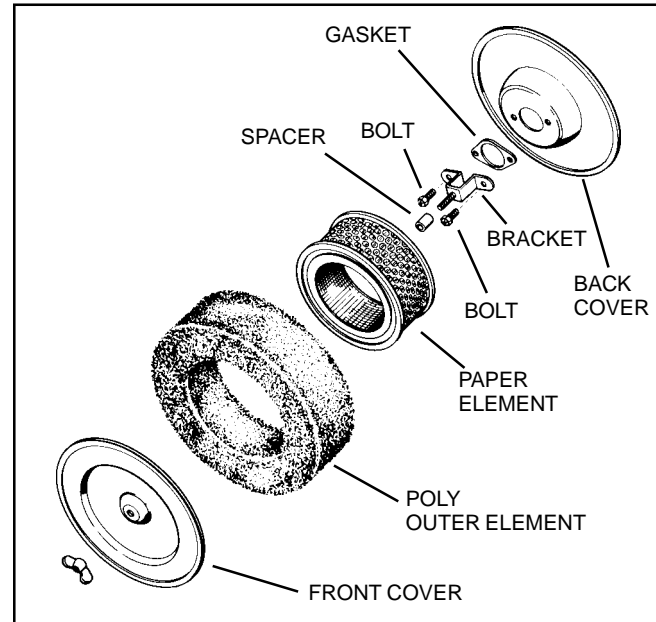

POLY-TYPE AIR CLEANER SERVICE. Clean and re-oil every 3 months or every 25 operating hours, whichever comes first. Clean daily if used in extremely dusty or dirty conditions. Proceed as follows:

Remove wing nut and cover.

Slide foam filter off paper filter.

Wash foam filter in water and detergent solution and squeeze, **Don't twist** until all dirt is removed.

Rinse thoroughly in clear water.

Wrap in a clean cloth and squeeze, **Don't twist** until completely dry.

Saturate foam filter with engine oil and squeeze, **Don't twist** to distribute oil and remove excess oil.

Clean top side of base and inside of cover thoroughly.

Replace foam filter, cover and wing nut. Tighten wing nut securely.

NEVER RUN ENGINE WITHOUT COMPLETE AIR CLEANER INSTALLED ON ENGINE.

SECTION 2. GENERAL CARBURETOR INFORMATION

CARBURETOR IDENTIFICATION. Tecumseh carburetors are identified by a model number and code date stamping on the carburetor as illustrated.

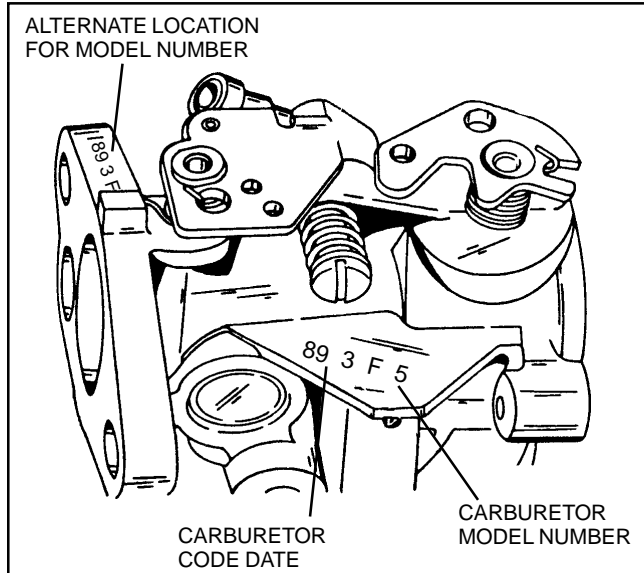

When servicing carburetors, use the engine model number or the model number on the carburetor and proper section in the Master Parts Manual or Microfiche Catalog for proper service information.

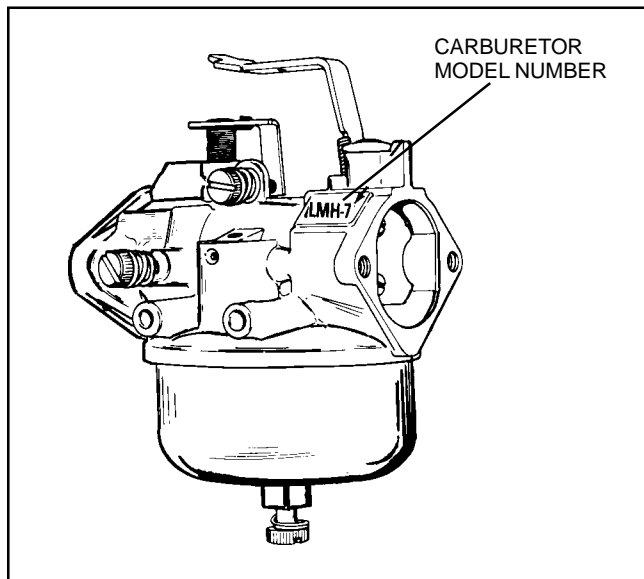

These carburetors are used on some HH80-100-120 and VH80-100 engines.

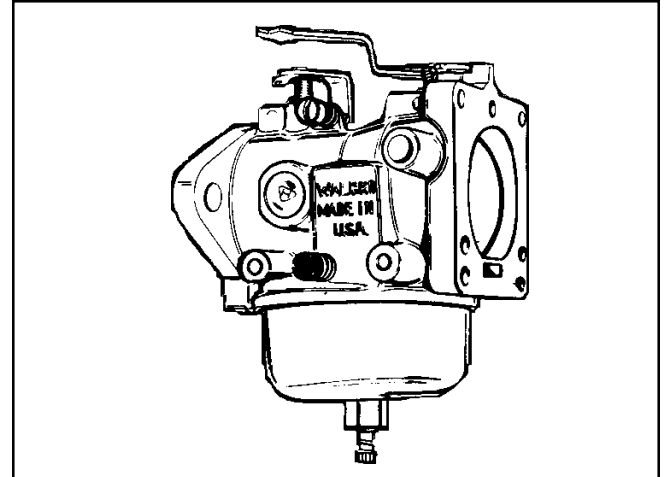

This carburetor is used on the Overhead Valve engine 12, 14, 16 & 18 horsepower.

FLOAT-FEED CARBURETORS. Float-feed carburetors use a hollow metal float to maintain the operating level of fuel in the carburetor. As the fuel is used, the fuel level in the carburetor bowl drops and the float moves downward. This actuates the inlet needle valve, to allow fuel to flow by gravity into the fuel bowl. As the fuel level in the bowl again rises, it raises the float. This float motion adjusts the fuel flow at the proper rate and keeps the fuel at the proper mixture level.

SECTION 3. TECUMSEH CARBURETORS

Following are initial carburetor adjustments to be used to start the engine. After the engine has reached operating temperature make final adjustments.

Main Adjustment Screw	HH80-100-120 VH100, 1-3/4 turns.
Idle Adjustment Screw	HH80-100-120 VH100, 1-1/4 turns

The Master Parts Manual or Microfiche has a direct engine-to carburetor reference list. Further identification of the carburetor is stamped on the carburetor body as shown. Refer to the standard service part number and the identification number on the carburetor body, in any correspondence.

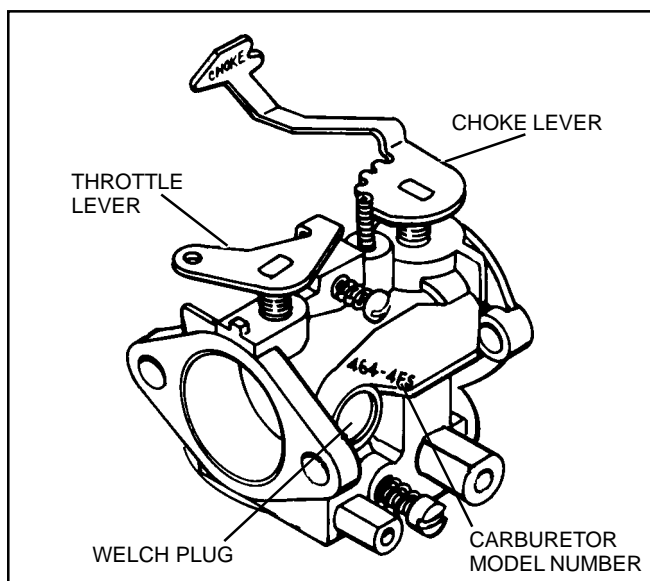

CARBURETOR DISASSEMBLY, INSPECTION AND ASSEMBLY. Carefully disassemble carburetor, removing all non-metallic parts, i.e., gaskets, viton seats and needles, "O" rings, fuel pump valve, etc.

THROTTLE. Examine the throttle lever shaft and shutter prior to disassembly. Replace any worn parts.

1. Remove the screw in the center of the throttle shutter and pull out the throttle shaft lever assembly.
2. When reassembling, replace the throttle shutter with identifying marks as positioned prior to disassembly. The throttle shaft must be held in tight to the bottom bearing to prevent the throttle shutter from riding on the throttle bore of the body, causing excessive throttle shutter wear and governor hunting.

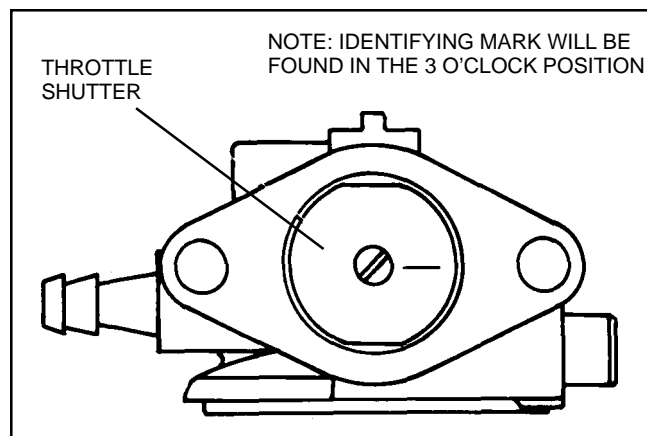

CHOKE. Examine the choke lever, shaft and shutter prior to disassembly. Replace any worn parts.

1. Remove the screw in the center of the choke shutter and pull out the choke shaft lever assembly.
2. When reassembling, replace the choke shutter with identifying marks as positioned prior to disassembly. Hold the choke shaft securely into the bearing bore when replacing the choke shutter.

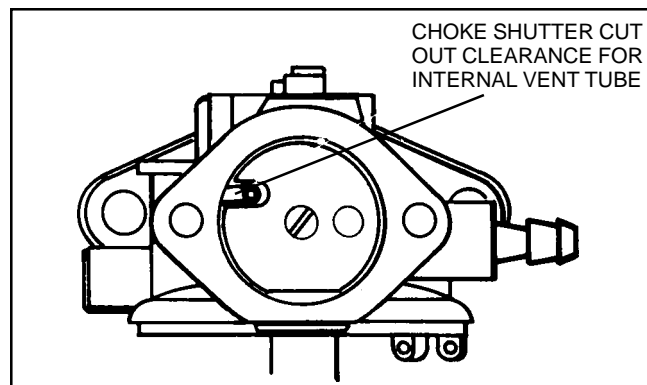

IDLE ADJUSTMENT SCREW. Remove the idle screw from the carburetor body and examine the point for damage to the seating surface of the taper. Replace any damaged parts.

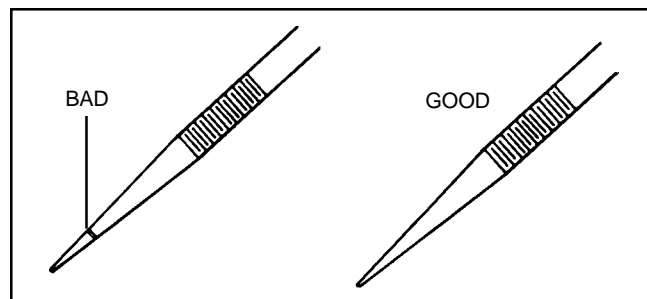

HIGH SPEED ADJUSTMENT SCREW. For service, examine the taper of the high speed adjustment screw. If the taper is damaged at the area where it seats, replace the screw and fuel bowl retaining nut as an assembly.

FUEL BOWL RETAINING NUT. Remove the fuel bowl retaining nut including fiber washer.

Examine the small fuel passage in the annular groove in the retaining nut. This passage must be clean for the proper transfer of fuel into the idle metering system. Replace any worn parts.

When replacing, torque the fuel bowl nut to 50-60 inch pounds.

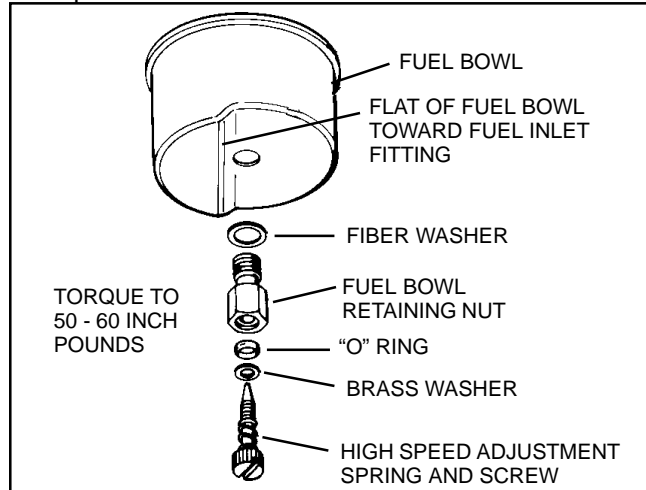

FUEL BOWL. Check the bowl for corrosion or dirt. Replace if necessary.

The fuel bowl must be free of dirt and corrosion. When tearing down carburetor for repair, replace fuel bowl "O" ring. Before installation lubricate the "O" ring with a small amount of oil for easier installation.

The fuel bowl flat surface must be positioned on the same side of the carburetor as the fuel inlet fitting or same side as the float hinge pin to assure full travel of the float.

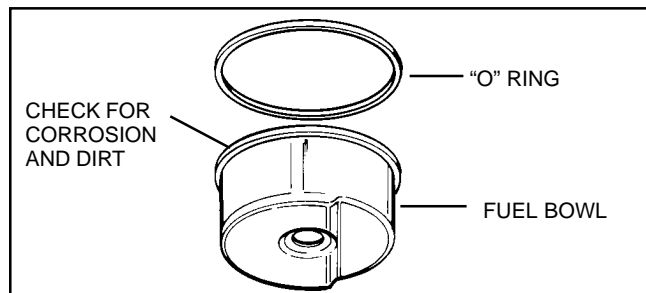

FLOAT. Remove the float. Examine the float for crushing or holes. Examine the float hinge bearing surfaces through which the float hinge pin passes and replace if worn.

INLET NEEDLE. The inlet needle is anchored to the float tab by a clip, to assure proper movement of the inlet needle off of the seat when the float drops. The inlet needle clip must be positioned as shown during reassembly.

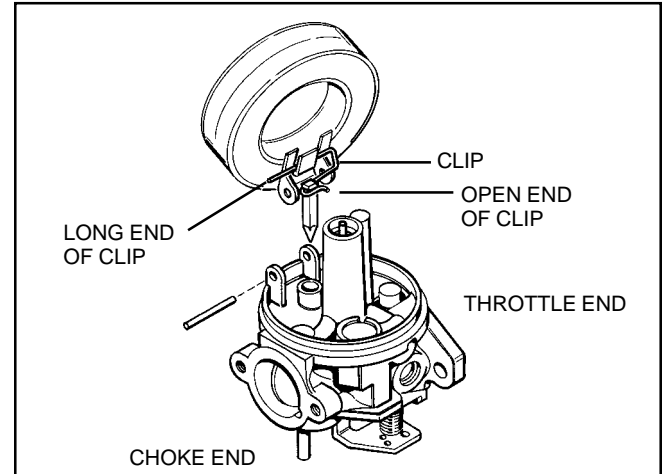

Examine the inlet needle. If any wear is evident, or any of the corners show signs of rounding, the needle should be replaced.

The inlet needle hooks onto the float tab by means of a spring clip. To prevent binding, the long, straight end of the clip should face the choke end of the carburetor as shown.

SERVICING THE VITON SEAT.

- a. **REMOVAL.** If the seat is to be replaced use the bent end of a paper clip or wire with a 3/32" (.24 mm) hook. Push the hook through the Viton seat hole. Then with the hook, pull the Viton seat out. Replace with a new seat.

NOTE: A #4 crochet hook can also be used for removal.

- b. **INSTALLATION.**

NOTE: After thoroughly cleaning the cavity, moisten the viton seat with oil.

Insert the seat with the grooved side into the cup. Press the viton seat squarely into the base with a punch.

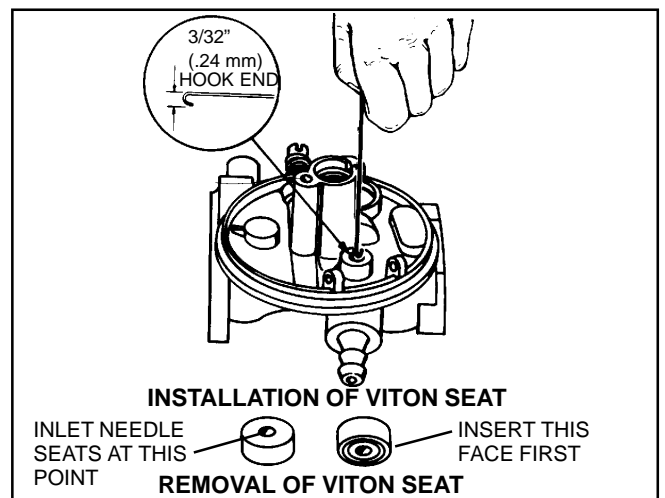

HIGH SPEED NOZZLE. The carburetor body contains a main nozzle emulsion tube pressed into the carburetor body to a predetermined depth and positioned within the venturi of the carburetor. Do not attempt to remove this main nozzle. Repositioning of this nozzle will seriously affect the metering characteristics of the carburetor and will require replacement of the entire carburetor.

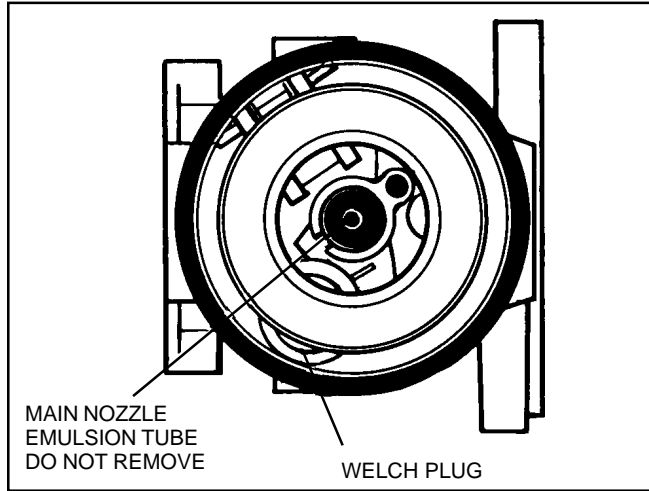

FUEL INLET FITTING. If necessary, this fitting can be removed by pulling and twisting. Be sure to install the fitting in the same position as the original. When installing the fitting, insert tip into the carburetor body, then coat the exposed portion of the shank with Loctite grade A; then press it in until the shoulder contacts the carburetor body.

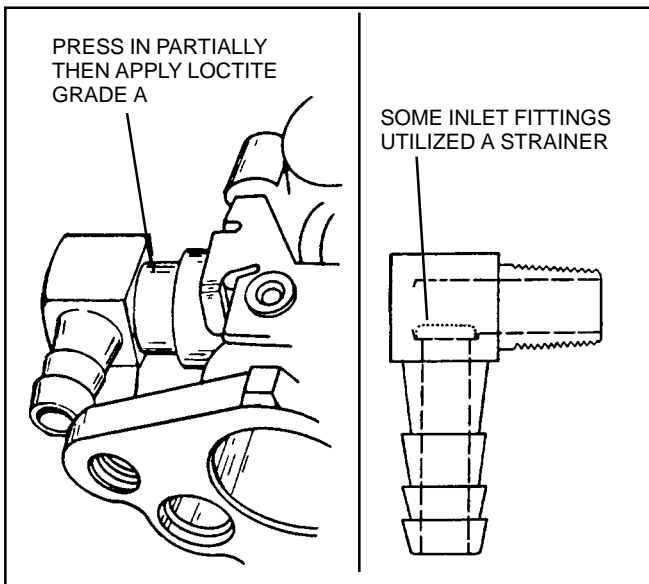

CARBURETOR BODY. When removing the choke and throttle shafts, check shafts and bearings in carburetor body for wear. Any looseness in these areas can cause dirt to enter the engine and cause premature wear. If dust seals are present, these should be positioned next to the carburetor body.

To do a proper cleaning job, welch plugs should be removed to expose drilled passages. To remove the welch plug, sharpen a small chisel to a sharp wedge point. Drive the chisel into the welch plug, push down on chisel and pry plug out of position.

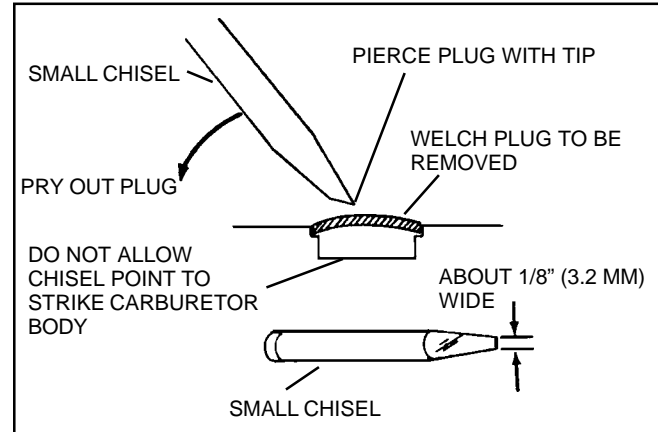

When all accessories and shafts have been removed, soak the carburetor in carburetor cleaner for a maximum of 30 minutes. Blow out all passages with compressed air in the opposite direction of normal fuel flow or use a soft tag wire. Clean all metallic parts with solvent.

To install a new welch plug after cleaning, place the welch plug into receptacle with raised portion up. With a punch equal, or greater than the size of the plug, merely flatten the plug. Do not dent or drive the center of the plug below the top surface of the carburetor.

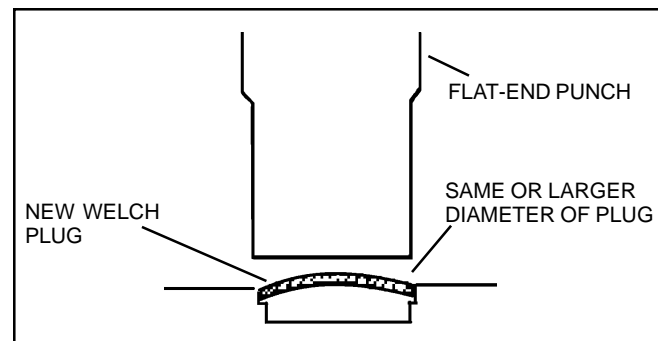

FLOAT ADJUSTING PROCEDURE

All Tecumseh carburetors with an adjustable float require the correct float height to achieve the proper operation and easy engine starts. To check the float setting, hold the carburetor in an upside down position. Remove the bowl nut, float bowl, and "O" ring. Place an 11/64" (4.369 mm) drill bit across the top of the carburetor casting on the opposite side and parallel to the float hinge pin. The float must just touch the drill bit when the bit is flush with the edge of the float. If the float is too high or too low, adjust the height by bending the tab accordingly. If the required adjustment is minor, the tab adjustment may be made without removing the float and carefully inserting a small bladed screwdriver to bend the tab.

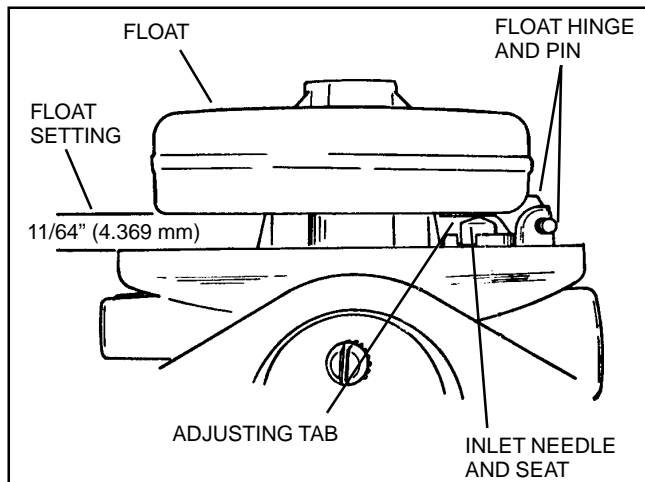

SECTION 4. WALBRO CARBURETORS

HH80 - 120, VH80 - 100

WALBRO CARBURETORS. Following are initial carburetor adjustments to be used to start the engine. After the engine has reached operating temperature, make final adjustments.

Main Adjustment Screw	HH80, 100, 120 VH80, 100, 1-1/2 turns off seat
Idle Adjustment Screw	HH80, 100, 120 VH80 100 1-1/4 turns off seat

For proper carburetion the atmospheric vent **MUST** be open. Examine and clean if necessary.

A sluggish engine speed control may at times be caused by dirt or paint on the throttle return spring. Clean if required.

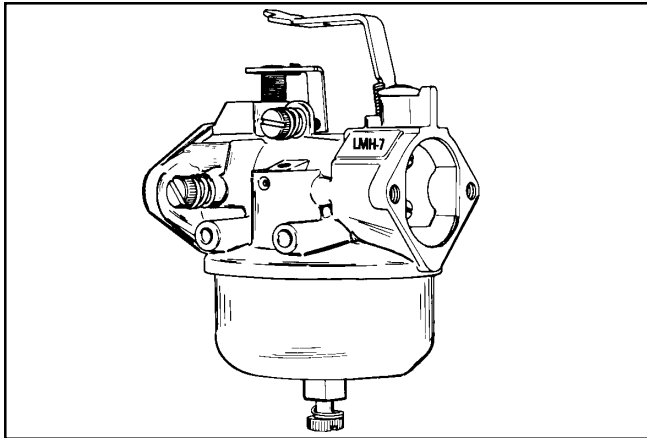

Choke lever positioning is maintained by the stop spring, replace if damaged.

The fuel inlet fitting should be checked if leakage is detected in the carburetor area. Do not screw in too tight, this may crack the carburetor body. The fuel bowl drain should also be examined in event fuel leakage is detected. It may be necessary at times to replace the internal rubber seat. Examine the throttle return spring if slow engine response is noted during operation. Correct by cleaning the throttle return or realigning the throttle plate.

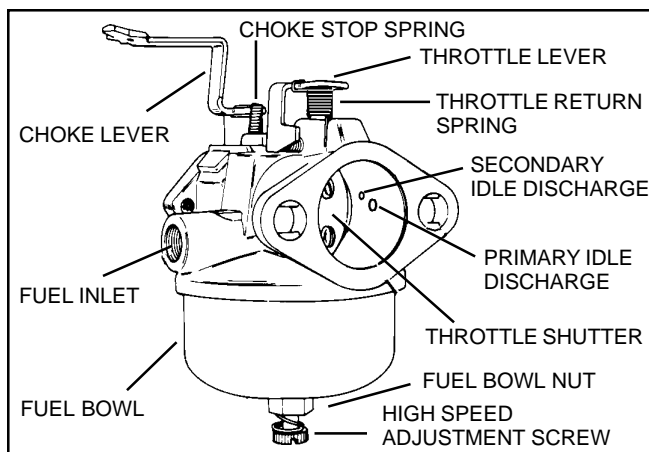

Install the throttle plate with the numbers (if present) facing out when closed. Move the throttle shaft to the closed position, place the throttle plate on the shaft and secure with the retaining screws. The throttle should move freely. If binding is present, correct by loosening screws and repositioning throttle plate.

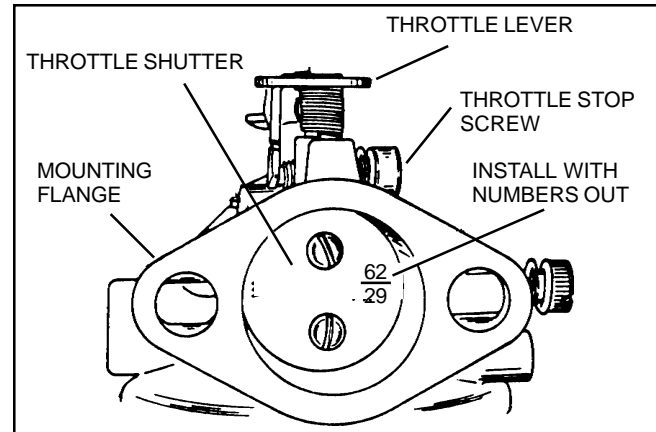

Examine the inlet needle. "A" is a needle that is serviceable, if the tip appears damaged as "B", replace needle and seat assembly. Tighten the inlet seat to 40 to 50 inch pounds (4.5 - 5.7 Nm). Always use a new gasket. Clean all dirt from the inlet seat cavity.

Normally the main nozzle should not be removed. It is possible to clean the carburetor with solvent and compressed air. Remove and replace the main nozzle only if the high speed needle seat is damaged or because of excessive dirt.

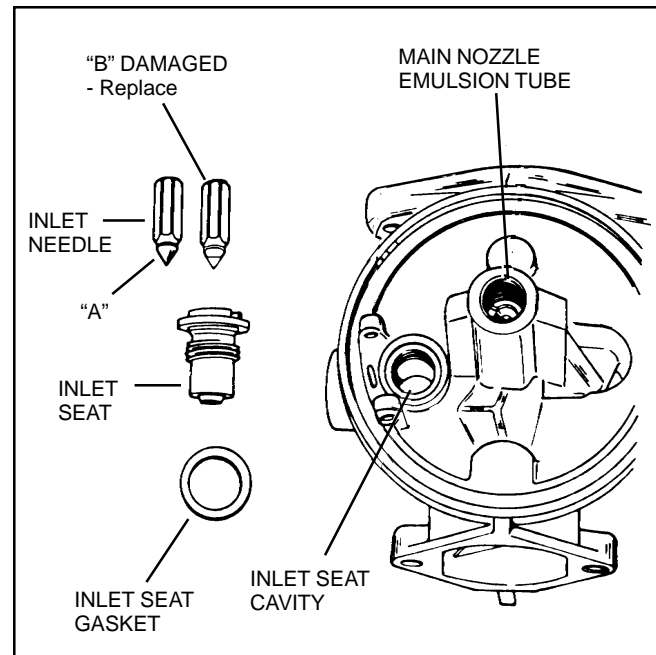

Do not remove the main nozzle. If it is necessary to remove the main nozzle to aid in cleaning, discard the main nozzle and use a service replacement nozzle with an undercut in the thread area. If the nozzle removed is undercut it can be reused. This procedure must be followed to assure delivery of fuel to the idle system.

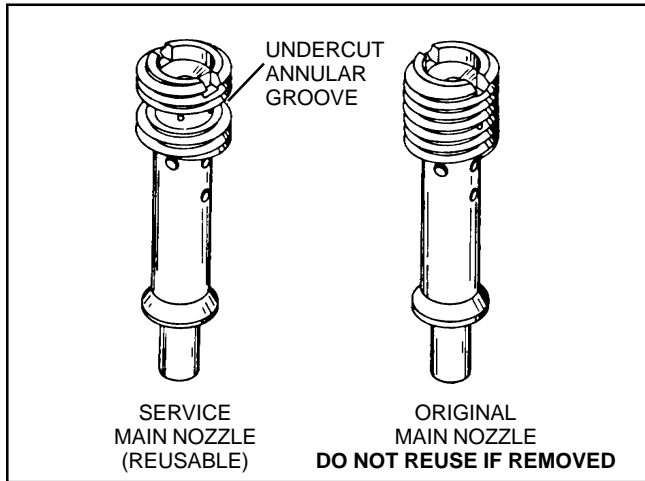

Float settings are measured opposite the float hinge. Remove float by pulling out float axle. Bend adjusting tab to correct setting. Always remove the float to make adjustments.

Examine the float hinge and axle for wear. If evident replace the parts.

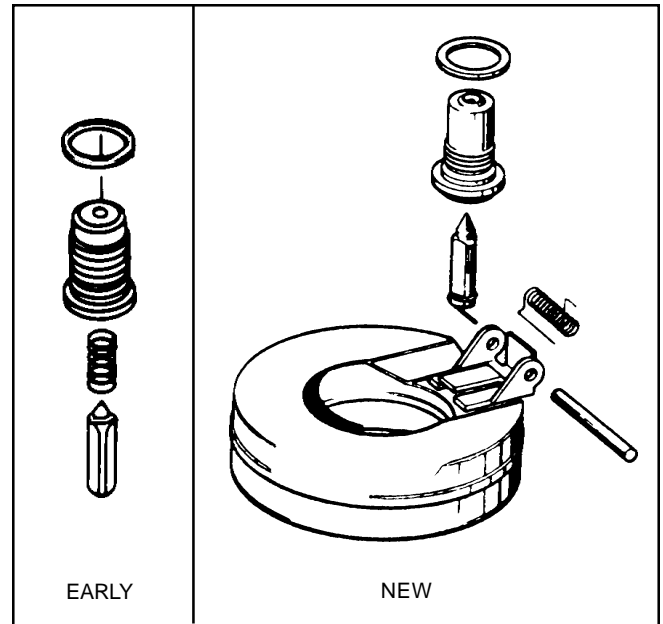
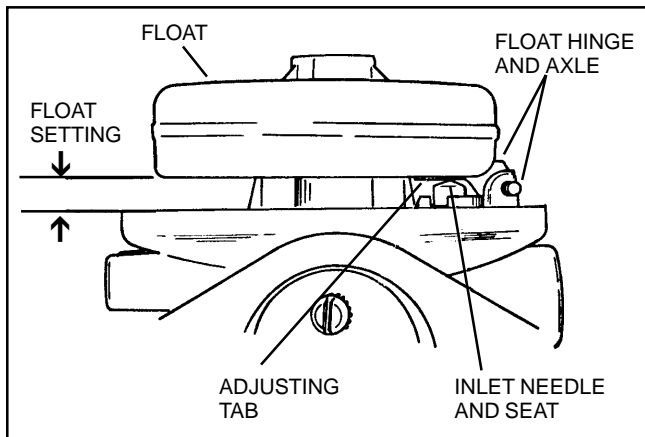

This shows early and new needle valve, seat, gasket, and spring assembly for large horsepower engine carburetors.

Early carburetors have a metal-to-metal needle and seat contact. The float setting for this model will be .110" - .130" (2.794 - 3.362 mm).

New carburetors contain a viton seal in the seat and a spring on the needle. For engines with the new carburetor and having a fuel pump, the float setting is .140 (3.556 mm).

For engines with the new carburetor, without a fuel pump, the float setting is .075 (1.905 mm).

The float setting on carburetors used on vertical 8 and 10 H.P. engines is .070" to .110" (1.778 - 2.794 mm). No variance for carburetor having a fuel pump.

The gasket must fit over the float spring as shown to avoid cutting by the spring when assembled.

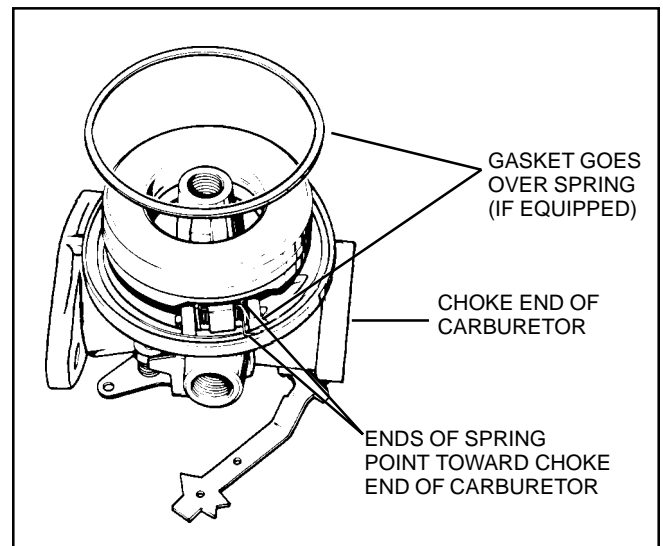

When assembling the float to the carburetor body, position the needle spring on the adjusting tag so that it hangs down. Hold the float spring under tension until the carburetor body will support the slight spring tension.

NOTE: THE SPRING ENDS MUST POINT TOWARD THE CARBURETOR CHOKE END.

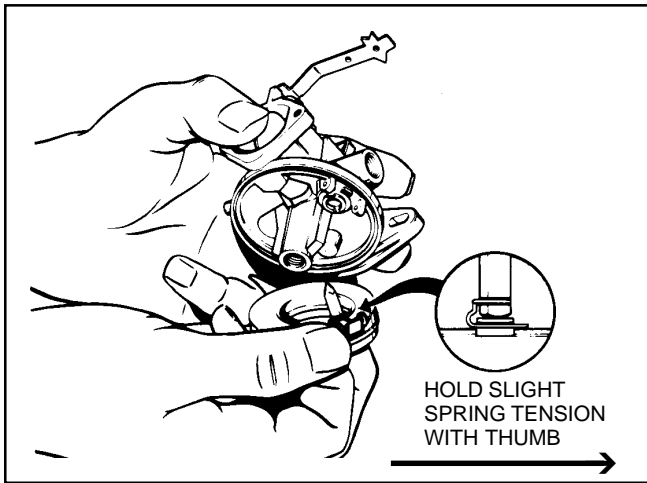

Position the choke shaft and shutter in the closed position prior to tightening the screws. Hard starting may be due to insufficient choking action because of a misaligned choke plate. Correct by readjusting choke plate to close completely.

A typical choke shutter found on horizontal engines is shown in the figure below. The full choke position of choke lever is counterclockwise when viewed from top of the carburetor. Note cut-out position of choke shutter.

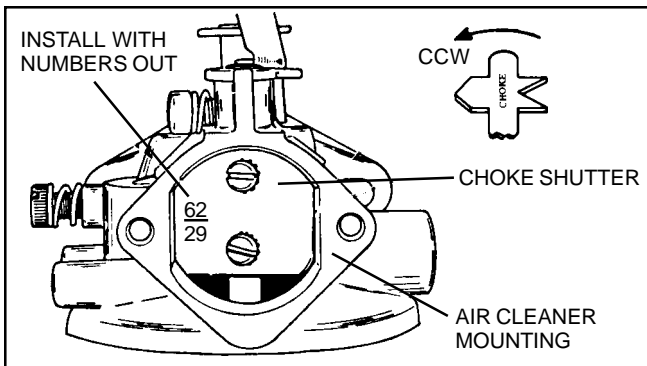
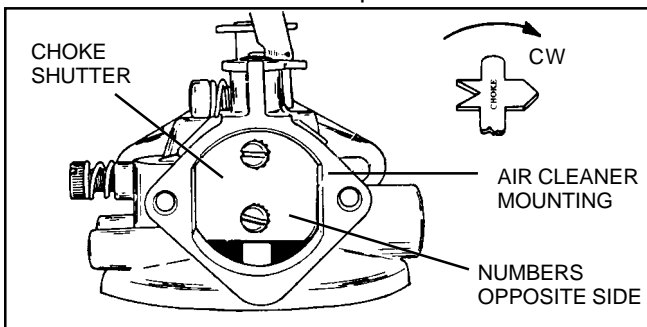
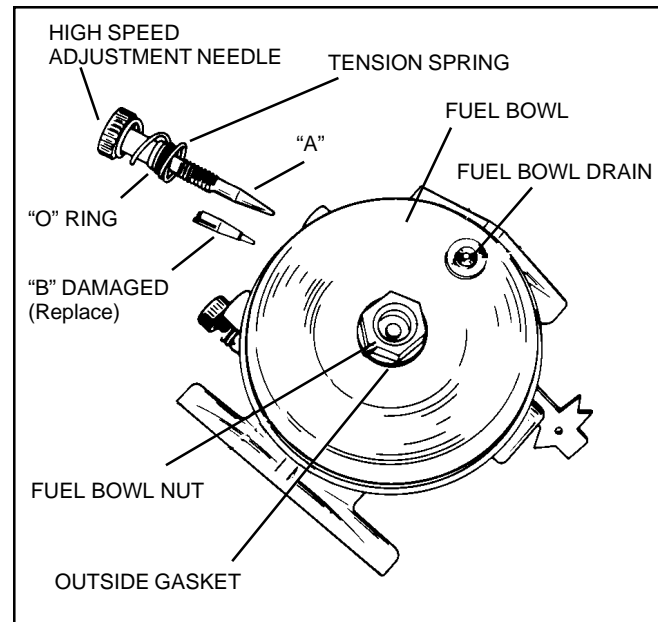

Figure below shows a typical choke shutter found on vertical engines. The full choke position of the choke lever is clockwise when viewing from the top of the carburetor. Note cut-out position of choke shutter.



Prior to removing the fuel bowl nut, remove the high speed adjustment needle. Use a 7/16" box end wrench or socket to remove the fuel bowl nut. When replacing the fuel bowl nut be sure to position the fiber gasket under the nut and tighten securely.

Examine the tip of the high speed needle, if it appears as illustrated, replace. If the tip of the high speed adjustment needle is damaged, the seat is probably damaged. The seat is part of the main nozzle. When replacing the high speed needle the main nozzle should also be replaced.



Use new gaskets when rebuilding the carburetor. If the fuel bowl to carburetor body gasket does not seat, enlarge by stretching with 4 or 5 quick short strokes. Fiber gasket must be used between center of fuel bowl and carburetor body.

The fuel pick up passage must be clean to assure adequate fuel flow from the fuel bowl to the metering systems.

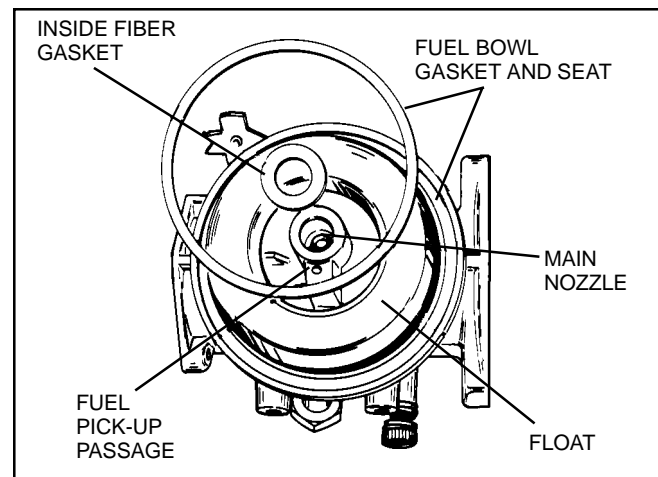

SECTION 5. OVERHEAD VALVE ENGINE CARBURETORS

Overhead valve engines utilize Walbro carburetors.

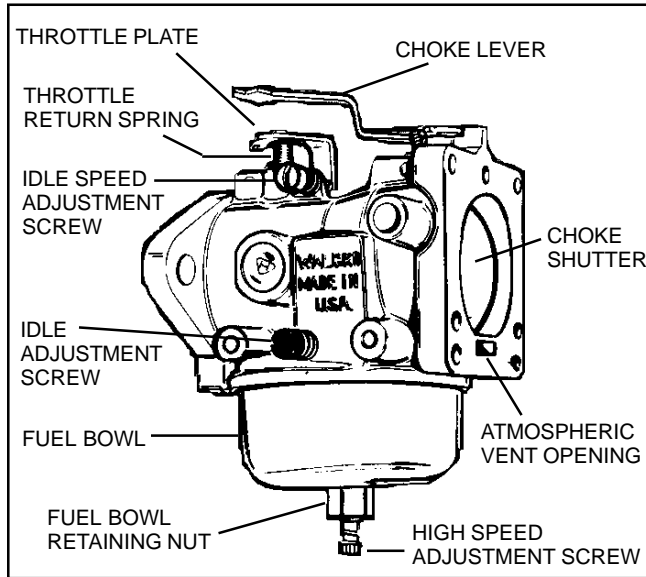

CARBURETOR ADJUSTMENT. Carburetor factory adjustment should not be changed. However, if required, perform the following: with engine running (Allow engine to warm up for 5 minutes). Open throttle (speed control at "RUN" or "FAST" position). Adjust high speed adjustment screw per chart, clockwise or counterclockwise until engine runs smoothly. With control in idle or slow position, adjust idle speed adjustment screw to obtain correct idle speed. If necessary, readjust idle adjustment screw clockwise or counterclockwise until engine idles smoothly.

CARB.	HIGH SPEED ADJ. SCREW*	IDLE ADJ. SCREW*
OH120 THRU OH180	1 TURN*	1 TURN*
*All Adjustments Off of Seat		

IDLE ADJUSTMENT SCREW. Close idle adjustment screw by turning clockwise. Close finger tight only. Forcing will damage screw.

OPEN IDLE ADJUSTMENT SCREW: 1 turn counterclockwise.

Start engine and with the throttle open (then return to idle position), adjust idle adjust screw one-eighth (1/8) turn at a time clockwise or counterclockwise until engine runs smoothly.

With control at "idle" or "slow" position, adjust idle speed adjustment screw to obtain correct idle speed. If necessary, readjust idle adjustment screw until engine idles smoothly.

CARBURETOR SERVICING

Throttle Shutter

Install the throttle shutter with the numbers facing out when closed. Move the throttle shaft to the closed position, place the throttle shutter on the shaft and secure with new retaining screws. The throttle should move freely. If binding is present, correct by loosening screws and repositioning throttle shutter.

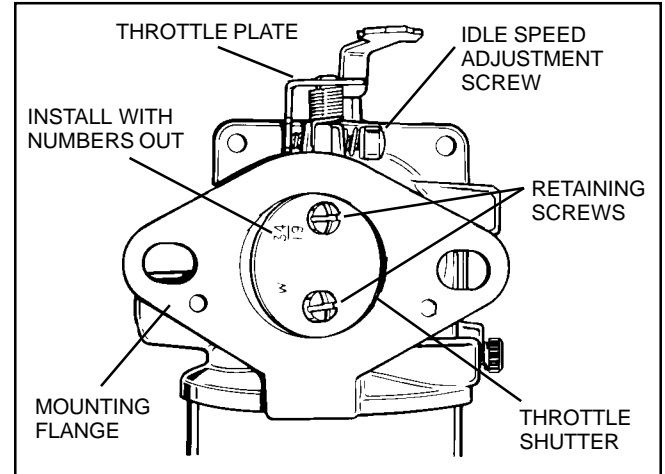

CHOKE SHUTTER. Position the choke shaft and shutter in the closed position to tighten the screws. Hard starting may be due to misaligned choke plate. Correct by readjusting the plate to close completely.

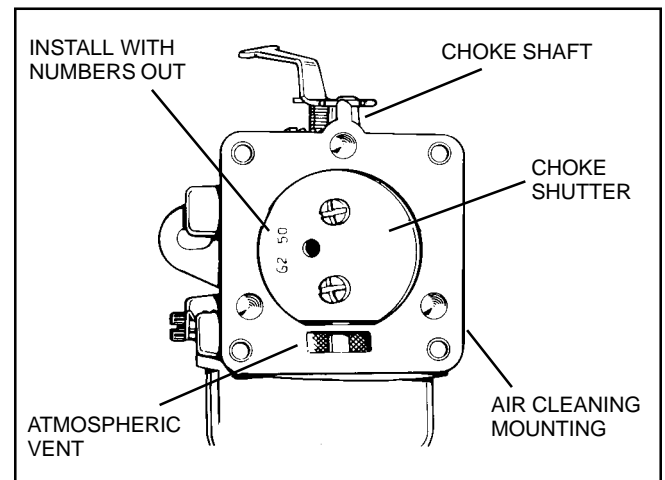

HIGH SPEED ADJUSTING SCREW. Prior to removing the fuel bowl nut, remove the high speed adjusting needle. When replacing the fuel bowl nut be sure to position a fiber gasket on each side of the fuel bowl.

Examine the tip of the high speed adjustment screw. If the tip of the screw is damaged, the seat, which is part of the main nozzle, is probably damaged. When replacing the screw, the nozzle should also be replaced with a service replacement nozzle only.

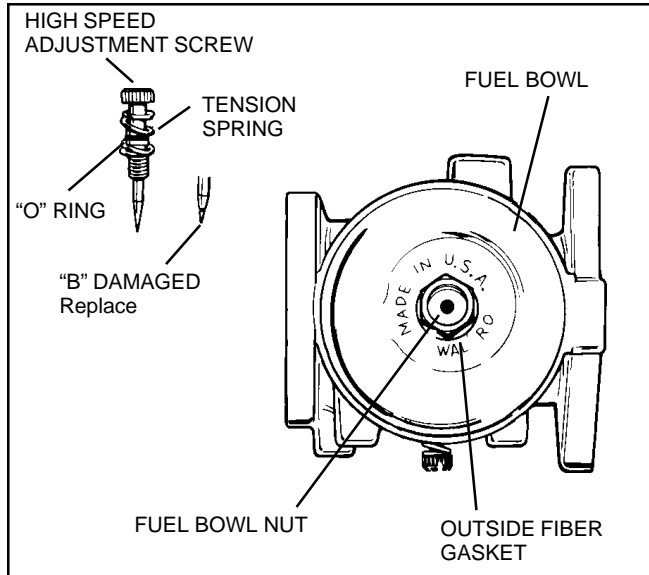

MAIN NOZZLE. Normally the main nozzle should not be removed, if it is, clean the carburetor with solvent and compressed air. Remove and replace the main nozzle only if the seat is damaged or is excessively dirty.

If it is necessary to remove the main nozzle, discard it and use a service replacement nozzle with an undercut in the thread area. If the nozzle removed is already under cut, it can be reused. This replacement assures delivery of fuel to the idle system.

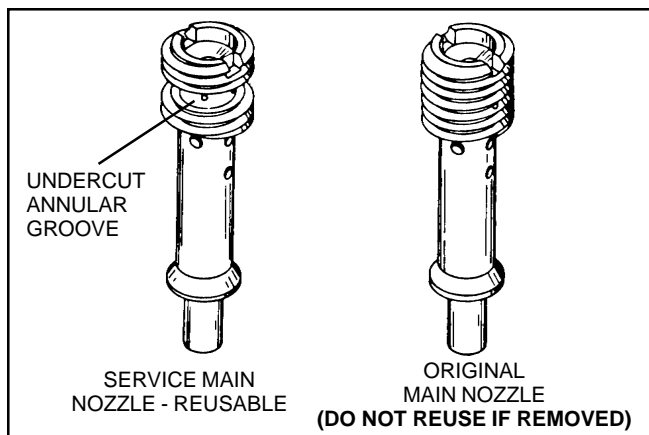

INLET NEEDLE & SEAT. The inlet needle and seat are replaceable as an assembly. If the tip appears damaged, replace the needle and seat assembly.

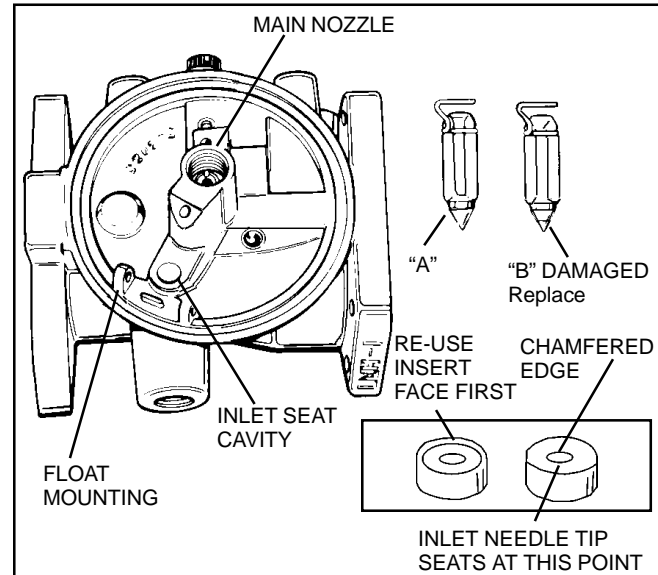

FLOAT SETTING. Float Settings are measured opposite the float hinge. Remove float by pulling out float axle. Bend adjusting tab to correct setting. Always remove the float to make adjustments.

Replace the float and axle if wear is evident. The float must measure .275" / .315" (6.985 / 8.001 mm) from top of boss to surface of float (closest to center).

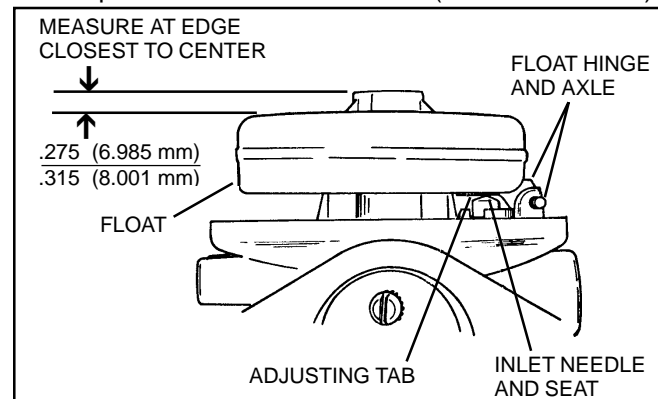

Position carburetor in an upright position.

If float is lower than dimensions shown in figure, bend outside tab GENTLY so float does not drop plus or minus .060" (1.524 mm) from base of boss.

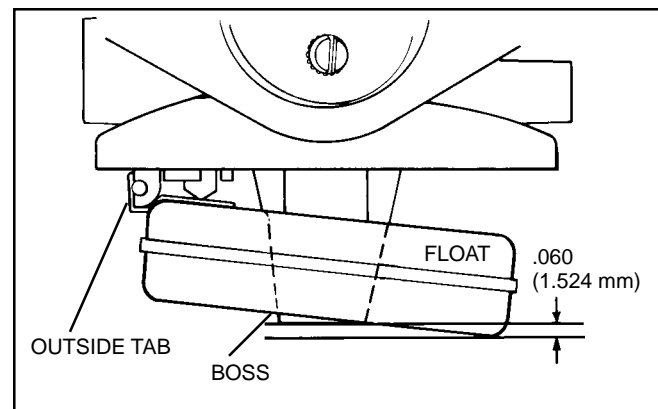

ASSEMBLING SEAT, SPRING & FLOAT. Shown below is the float, hinge pin, seat and the float spring.

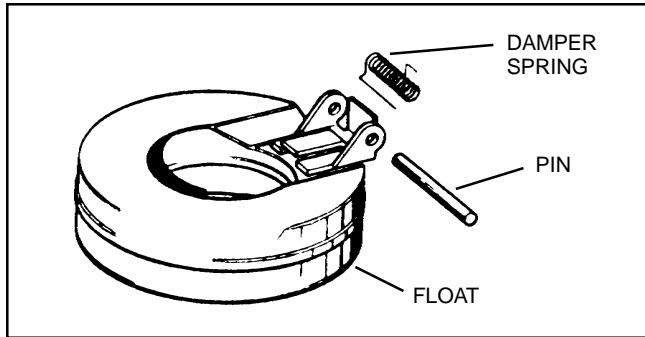

When assembling the float to the carburetor body, position the needle spring on the adjusting tang so that it hangs down. Hold the float damper spring under tension until the carburetor body will support the slight spring tension. The spring ends must point toward the carburetor choke end.

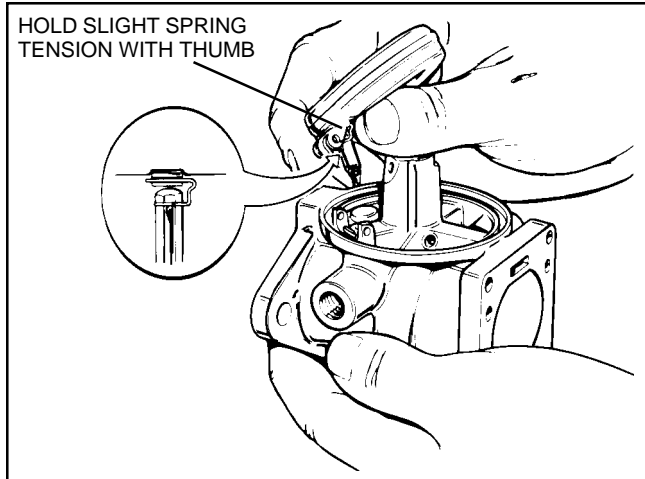

The bowl gasket must be positioned over the float spring as shown.

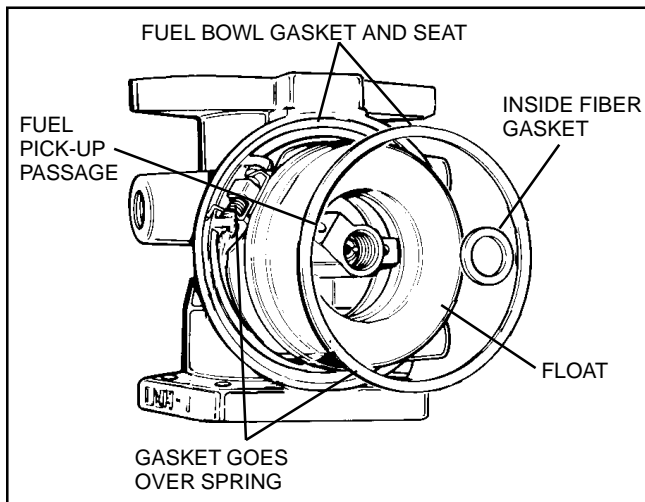

FIXED HIGH SPEED CARBURETOR. On carburetors of a later design the high speed screw has been replaced by a fixed speed nut. Adjustment is made only on the idle adjustment screw since the high speed setting is fixed.

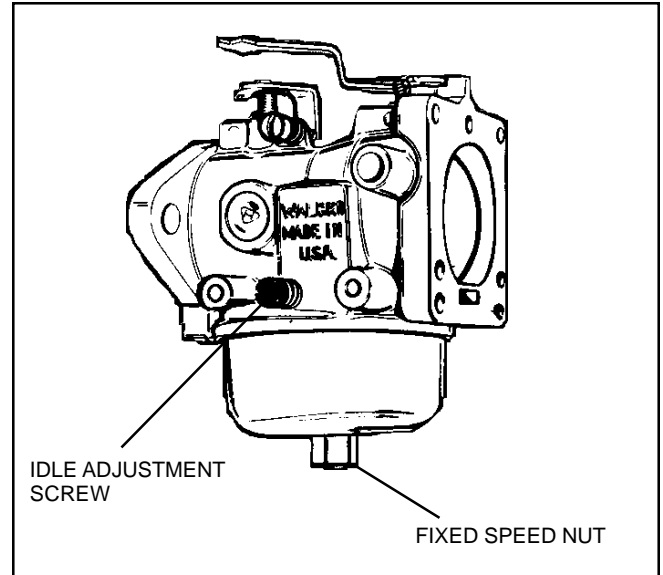

WALBRO WHG. The early production OH engine was equipped with a LMH carburetor. The newer engines since 1987 have been manufactured with a WHG carburetor. Service replacements are all WHG, which include an instruction sheet covering service.

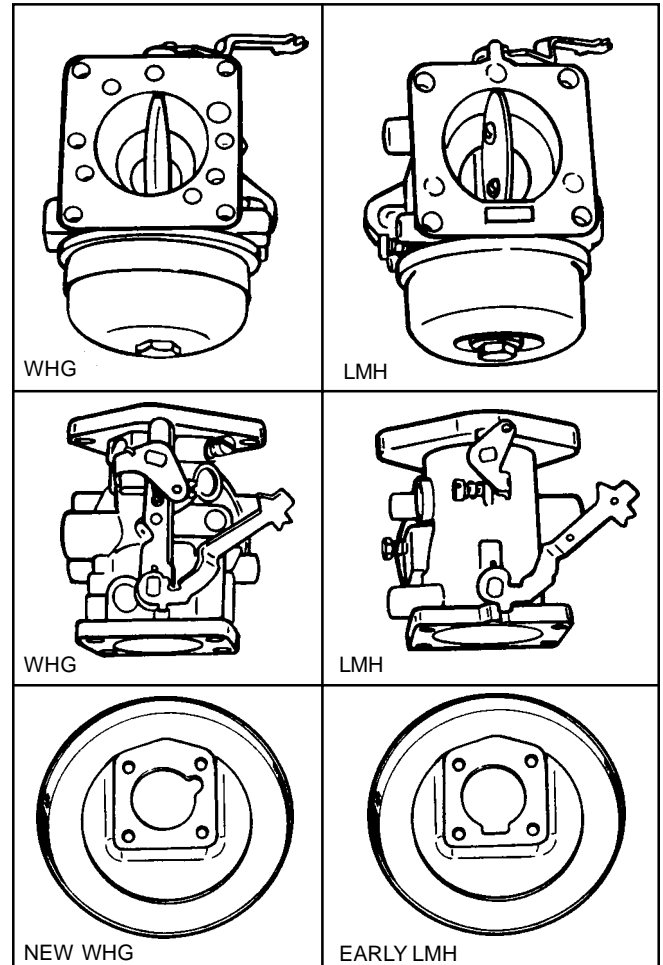

SECTION 6. GOVERNORS

This Governor Assembly is used on current production HH & OH Tecumseh Engines.

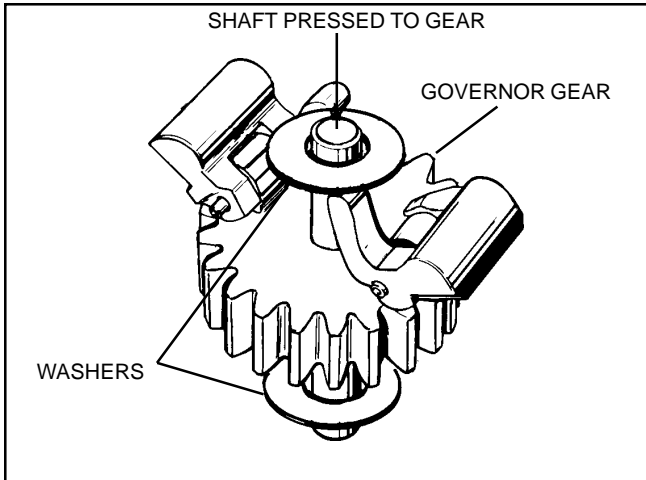

To position the governor gear assembly, insert the shaft opposite the flyweights into the cylinder block.

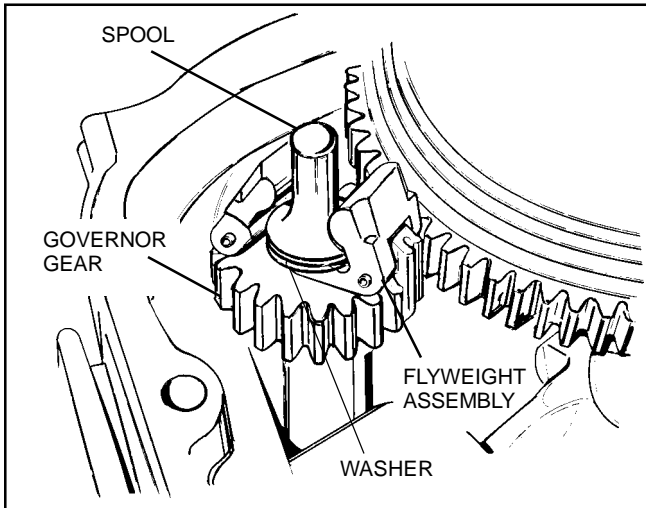

Position the governor gear assembly (with washer under governor gear) to mesh with the camshaft gear. Place the governor spool (with washer under the spool) on the governor gear assembly, with the fingers of the flyweights under the rim of the spool.

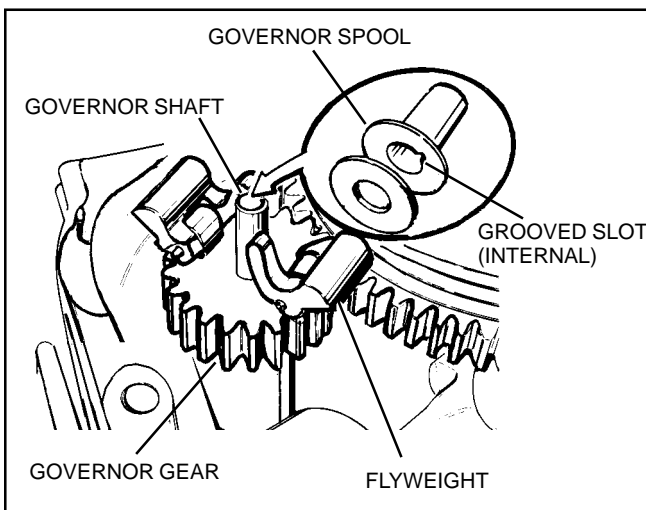

There is an oil groove on the inside of the spool to prevent oil pressure from building up under the spool.

Position the governor gear and flyweight assembly on the governor gear shaft. Secure with a retaining ring. Place the governor spool on the governor gear shaft.

The spool is positioned on the governor gear shaft with the fingers of the flyweight under the rim of the spool.

Some models have an oil hole in the closed end for lubrication. **CAUTION:** On reassembly make sure hole is open. Other models have a groove on the inside that serves the same purpose.

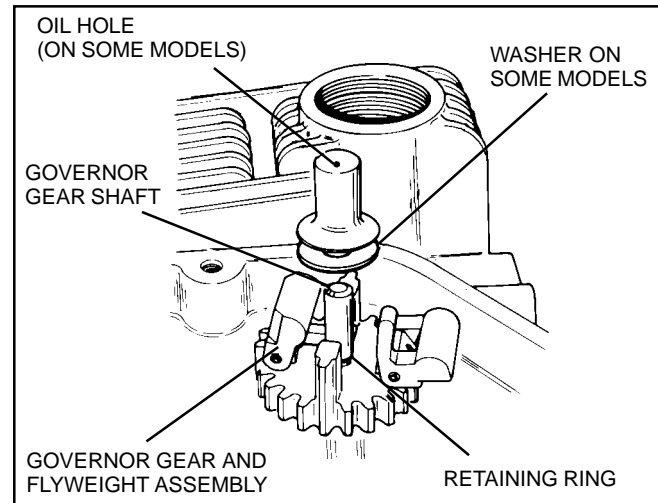
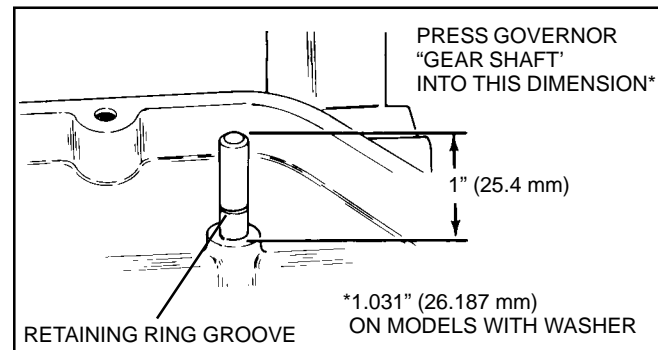

Remove the governor gear shaft by threading the shaft with 1/4-28 die. Place a number of washers on the shaft and turn on a nut. By tightening the nut against the washers the shaft will be pulled from the cylinder.

For old style governor assembly, position the governor gear shaft over the opening in the cylinder block and tap lightly with a hammer to start. Use a press to position. Refer to top picture for proper pressed in depth. Measure from the top of the governor gear shaft to the machined surface on the cylinder block.

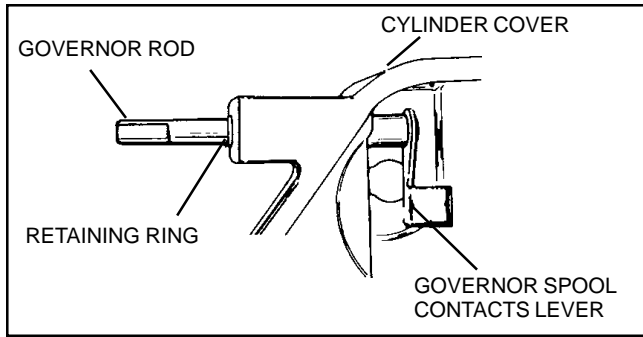

The governor rod is retained in the cylinder cover bushing with a retaining ring.

The governor spool moves the governor rod by contacting the lever. Outward movement of the governor spool moves the governor levers and carburetor throttle to a closed position.

The lever must contact the governor spool tightly for best governor control and for correct adjustment procedure.

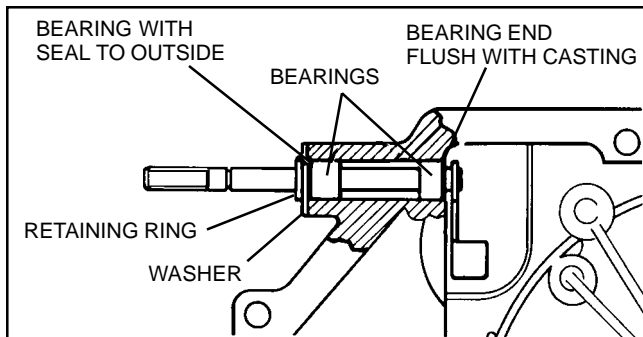

The governor rod on some valve-in-head model engines utilize needle bearings. If bearing(s) are removed, always install new bearing(s). Remove with 3/8" (9.525 mm) diameter punch and mallet. To install, tap the first bearing in until the bearing end is flush with casting. Holding a finger over hole will indicate when bearing is driven into casting far enough. Drive the outside bearing in with edge flush with outside surface of casting and seal (in bearing) at outside end.

GOVERNOR ADJUSTMENT FOR HORIZONTAL ENGINES (See Picture: Governor Adjustment for Horizontal Engines)

- Move remote controls to RUN position.
- Loosen Screw "A".
- Pivot plate "B" counterclockwise (ccw) and hold.
- Move lever "C" to left.
- Tighten screw "A" securely.

When the governor is properly set, the carburetor throttle lever will be in a wide open position when the controls are set for starting.

The governor spring is to be anchored in the bottom center hole (D) of plate "B". Do not stretch or cut the governor spring. Above adjustments will correct any variations in governor control.

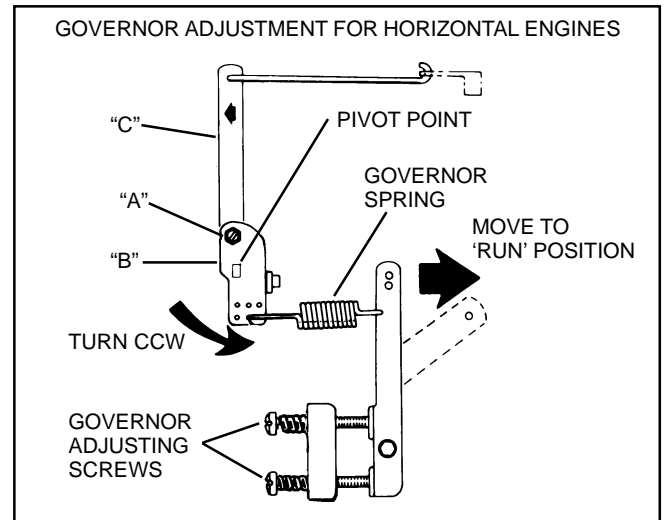

1. **SETTING VARIABLE SPEED ADJUSTING SCREW.** Before attaching the bowden wire, set the engine for maximum R.P.M. (See Mfg. specifications) with engine running. Use a good tachometer. Move lever "A" clockwise until lower end strikes the adjusting screw at "1". (See picture below)

Loosen lock nut on adjusting screw and turn in to decrease R.P.M. Turn out to increase R.P.M.

CAUTION: DO NOT EXCEED RECOMMENDED R.P.M.

2. **ADJUSTING FIXED SPEED.** The fixed speed adjusting screw is the optional position "2". Adjust it by starting the engine, then loosening the locknut. Turn screw in to increase R.P.M. and out to decrease R.P.M.

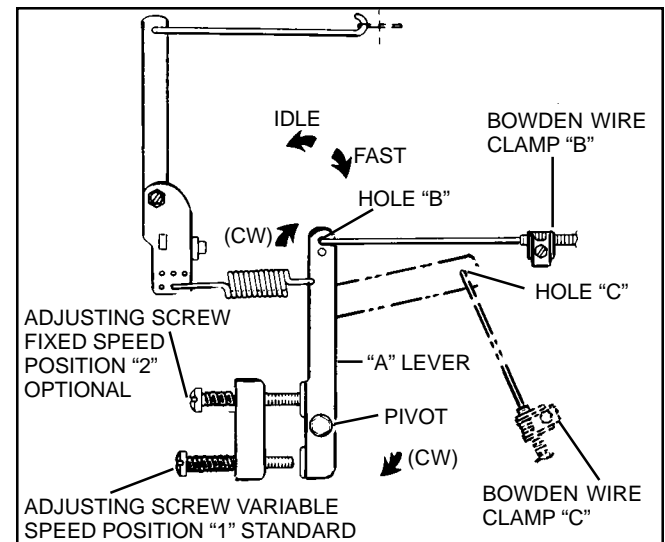

VERTICAL CRANKSHAFT GOVERNOR ADJUSTMENT.

Move remote controls to RUN position.
 Loosen screw "A".
 Turn plate "B" counterclockwise (ccw) and hold.
 Move lever "C" to left.
 Tighten screw "A" securely.
 When the governor is set properly the carburetor throttle will be in wide open position.

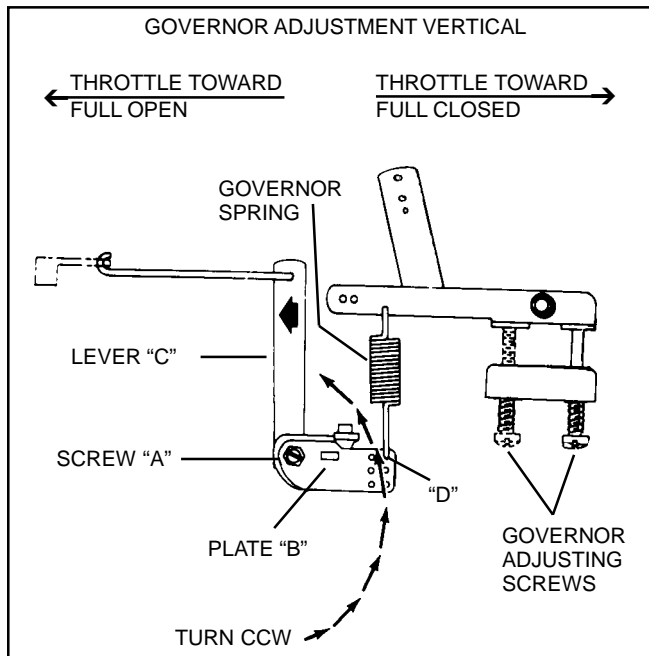

VARIABLE SPEED ADJUSTMENT. Before attaching the remote speed control (bowden wire) set the engine for maximum R.P.M. (See Mfg. specifications). Use a good tachometer.

Move lever "A" clockwise until lower end strikes the adjusting screw "1".

Loosen lock nut on adjusting screw "1" and turn in (clockwise) to decrease R.P.M. and out counterclockwise to increase R.P.M.

CAUTION: DO NOT EXCEED RECOMMENDED R.P.M.

ADJUSTING FIXED SPEED. The fixed speed adjusting screw is the optional position "2". Adjust it merely by starting the engine and after loosening the lock nut turn screw in (clockwise) to increase spring tension and hold engine at higher R.P.M. and out (counterclockwise) to decrease tension on spring and allow speed to be decreased more easily.

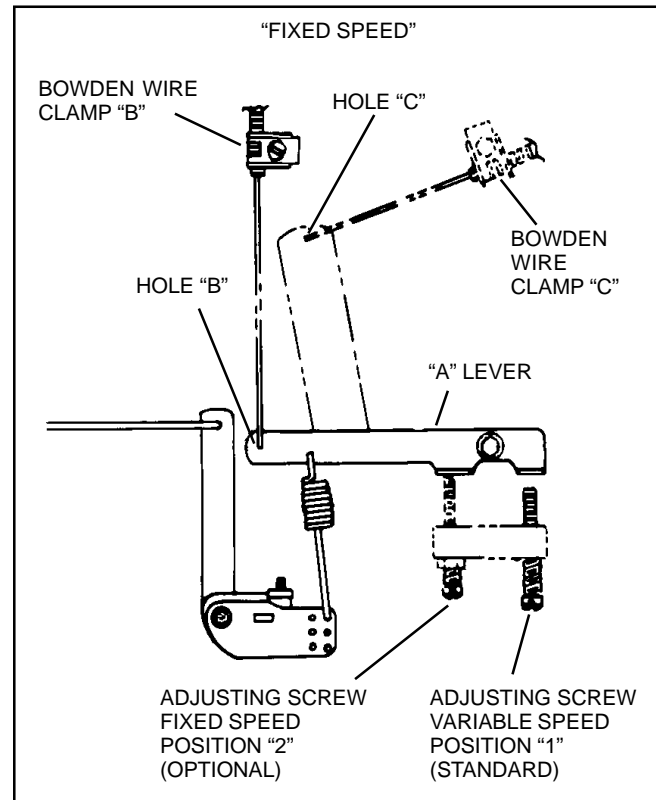

SECTION 7. IMPULSE FUEL PUMP

IMPULSE FUEL PUMP. This pump is mounted onto the carburetor inlet and has connections from the fuel supply and also a pulse line to the engine crankcase.

CAUTION: IN ORDER FOR THE PUMP TO OPERATE SATISFACTORILY THE CORRECT OIL LEVEL IN THE CRANKCASE MUST BE MAINTAINED. TOO MUCH OIL WILL ADVERSELY EFFECT THE PUMPS OPERATION.

It is operated by changing pressure created by the engine piston movement and transmitted to the pump through a pulse line. The increasing and decreasing pressures acting on the diaphragm and flap valves lift fuel from the fuel tank to the carburetor of the engine.

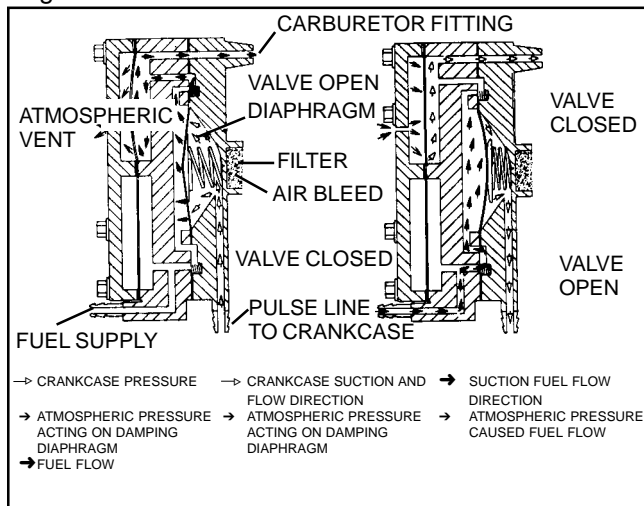

To service, separate the pump by removing the four (4) screws. Clean all new parts with a solvent and install a new kit which consists of coil springs, gaskets and diaphragms.

The diaphragms must be installed against the center body with the gaskets against the outside covers. The parts are designed so they cannot be misassembled without damage.

To test the unit, assemble the carburetor to the engine, leaving the pump off. Connect gravity fuel feed supply to the carburetor. With the pulse line connected to the pump and engine running, a definite flow should result.

If the flow is erratic or intermittent, the pump needs repair or replacement.

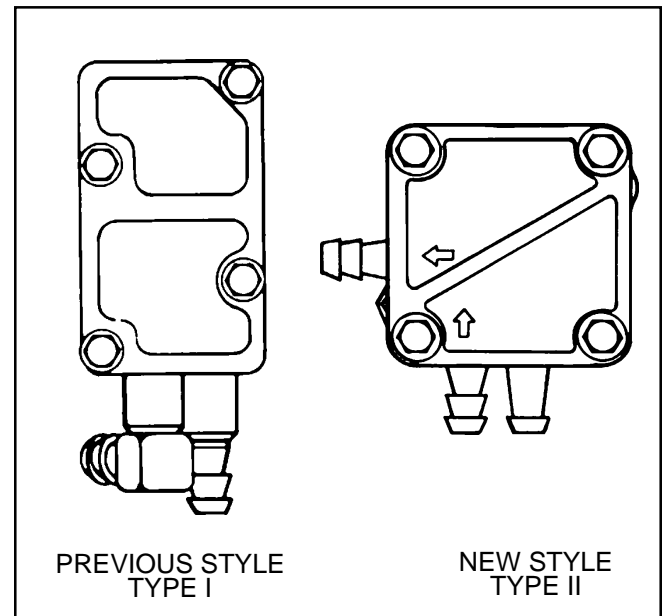
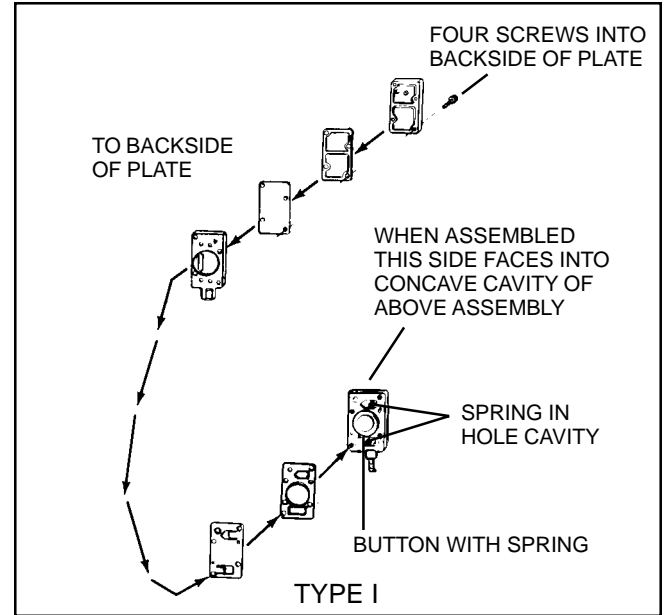

The new style pump (TYPE II) will replace older (TYPE I) pumps. An assembly kit is available with instructions and all the parts needed to convert to the new style. If a complete replacement of an old style is not necessary, a repair kit is still available.

CHAPTER 3. REWIND STARTERS, ELECTRIC STARTERS, TROUBLESHOOTING AND GENERATORS

SECTION 1. REWIND STARTERS

REWIND STARTER DISASSEMBLY PROCEDURE

1. Clamp starter in a vise and pull rope out, and clamp pulley.
2. Untie knot in rope and remove.
3. Slowly release spring tension.
4. Remove retainer screw, retainer cup; starter dog and spring, and brake spring.
5. Lift out pulley, turn spring and keeper assembly to remove from housing.

Replace all worn or damaged parts.

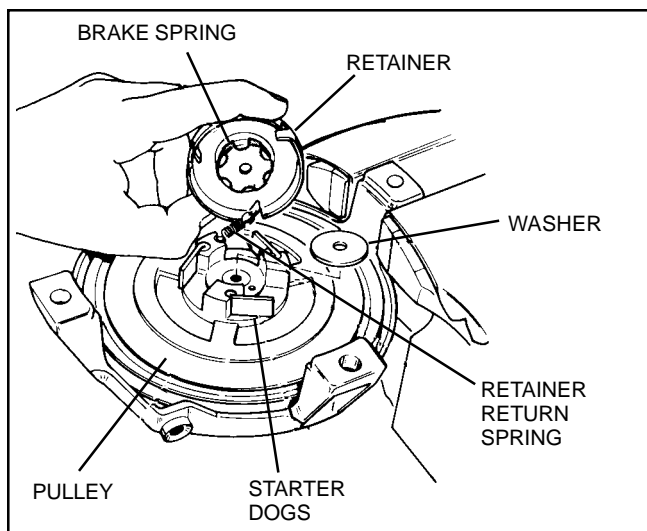

SPRING REPLACEMENT. Disassemble the starter completely.

New springs are enclosed in retainers. Be sure spring is positioned with wrapping in direction as illustrated. Position new spring and retainer over housing and press the spring out of the retainer into the starter housing.

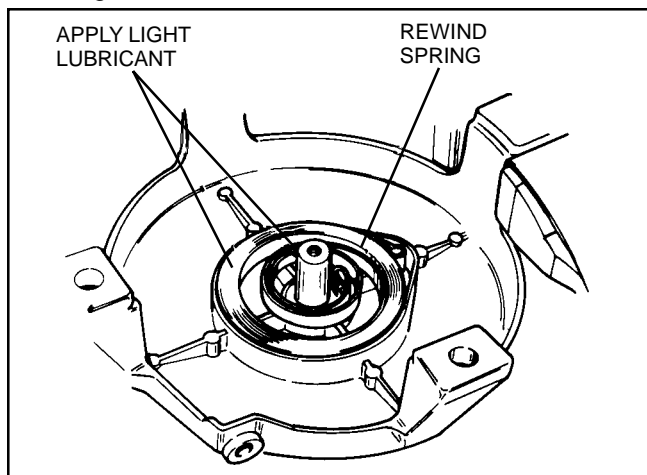

REASSEMBLY. Lubricate the recoil spring and center shaft with a small amount of light grease. Place the pulley over the center shaft and bottom. Insert a 1/8" (3.175 mm) punch or rod into the through hole in the pulley, and turn the pulley. This will aid in positioning and engaging the spring.

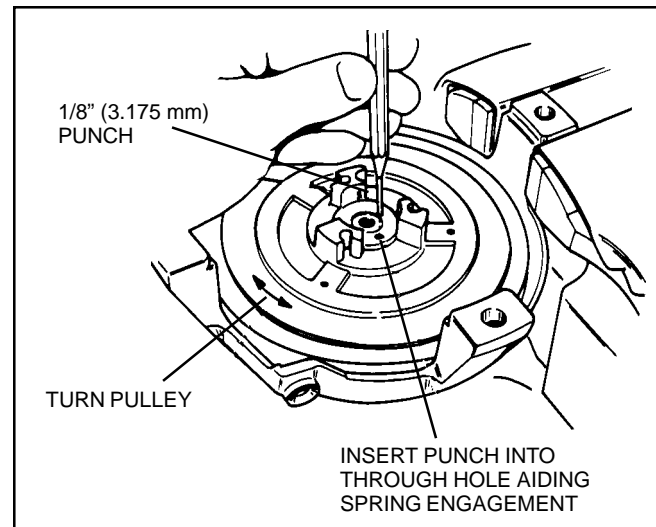

REWINDING SPRING AND REASSEMBLY. Place the large washer, 1-3/8" (34.925 mm) over the center shaft. Insert the dogs, so that they will fold in close to the center. Press the brake spring on the retainer. The brake spring must be a tight fit on the retainer. Hold the retainer and brake spring assembly at an angle to engage the return spring to the dowel on the pulley. Secure with the center screw and washer and tighten securely. Failure of the starter to engage may be traced to either a loose center screw, or loose brake spring. Tighten the screw or replace the brake spring. Replace the rope as outlined.

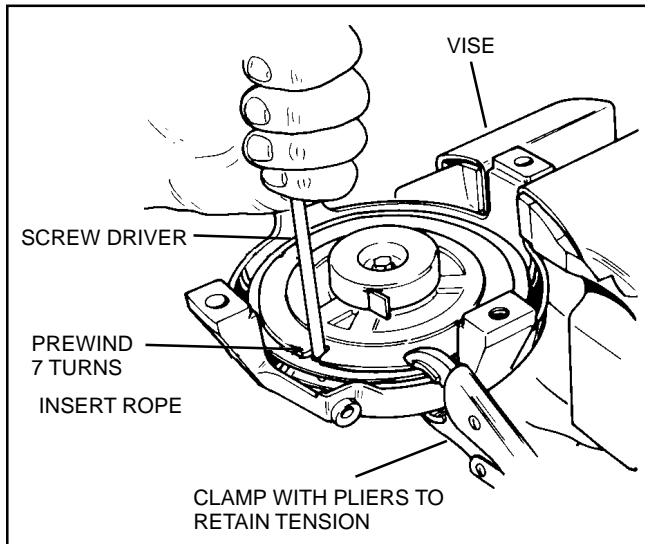

ROPE REPLACEMENT. Prepare the rope, place a thin 3/4" (19.05 mm) diameter washer with a 1/4" (3.175 mm) hole on the rope and tie a knot. The other end of the rope should be thinned to a point for easier threading.

Clamp the starter in a vise, upside down, by one leg opposite the rope outlet. Place a screw driver in the rope hole of the pulley and turn counterclockwise until tight, then allow to unwind until hole in pulley for rope lines up with hole in housing. Clamp the pulley in this position with lever action pliers. Clamp over starter housing and pulley, protect the painted surface.

Insert the rope into the pulley hole and guide it with needle nose pliers through the rope outlet in the housing. Secure the handle with a double knot. Hold the rope taut, release the pliers and allow the rope to wind on the pulley.

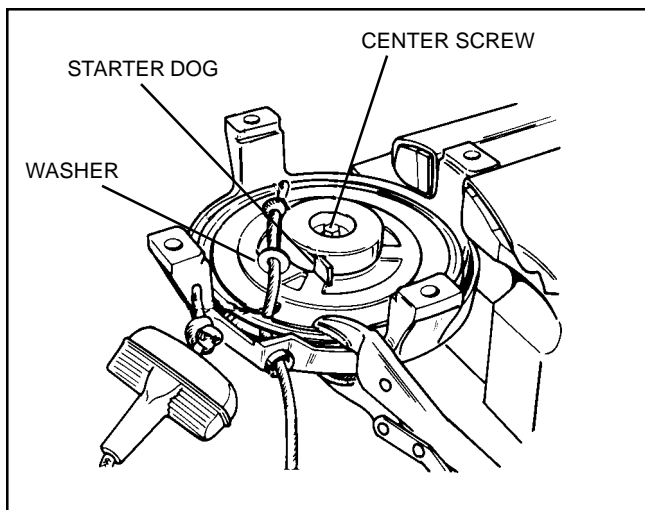

ASSEMBLING STARTER TO ENGINE. It is important to center the starter hub containing the starter dogs in the center cup so there is equal contact on all the dogs into the teeth of the cup.

Before securing the starter with the mounting screws, place the hub into the cup then pull the rope enough to cause the starter dogs to equally engage in the teeth. With the dogs securely in the cup, tighten the mounting screws to 40-60 inch pounds (4.5 - 6.8 Nm) torque. If mounting holes do not line up, blower housing is bent and must be replaced.

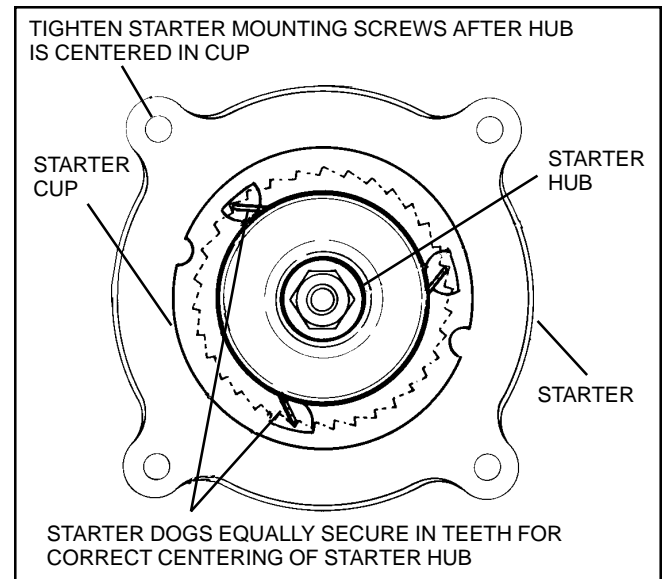

ON SOME VALVE-IN-HEAD ENGINES:

PULLEY (SHEAVE-TYPE) STARTER. Consists of a rope sheave-type. The engine comes equipped with starter rails and the blower housing is constructed with a removable plate for conversion to an electric start.

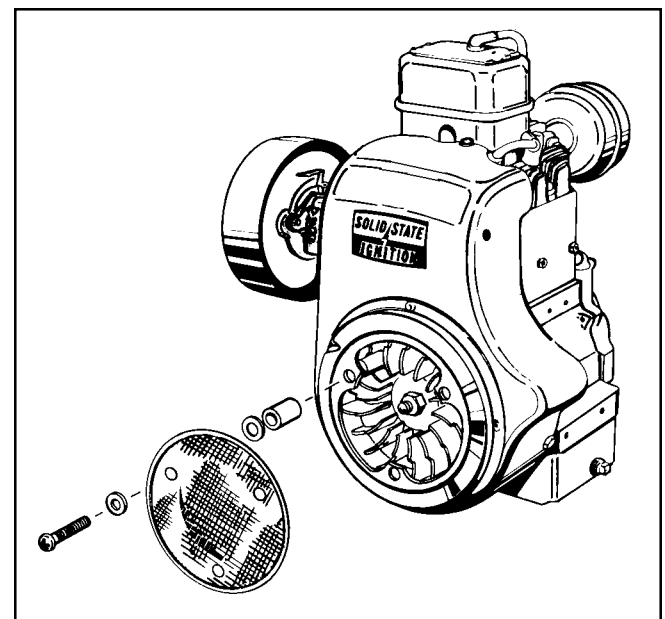

SECTION 2. ELECTRIC STARTERS

STARTER SERVICE, DISASSEMBLY AND INSPECTION. Part No. is found on identification tag. Used on large frame vertical and horizontal engines.

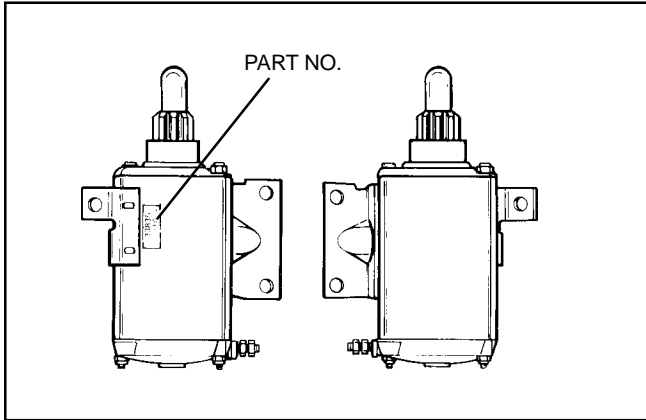

Repair of these starters consists of replacement of parts shown in the exploded view.

1. Testing

Test 12 Volt starters under the following conditions:

- Conduct test with fully charged battery.
- Engine and oil temperature approximately 70° F (21°C).
- Engine contains recommended oil.
- Cranking test not to exceed 10 seconds.
- Parasitic loads removed from engine.

MODEL	AMPERES	ENGINE RPM
33835	70 MAX.	600 MIN.

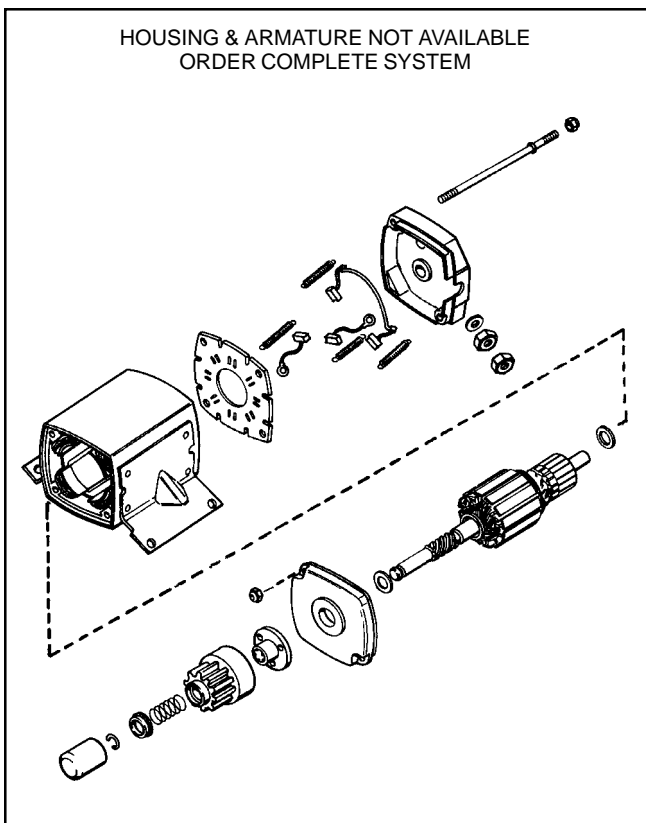

Test and trouble shooting procedures for 12 volt starters can be found in other Sections of this chapter.

2. Disassembly.

- Remove two (2) lock nuts from thru bolts on drive end of starter.
- Grasp drive end of starter and remove from housing as an assembly.

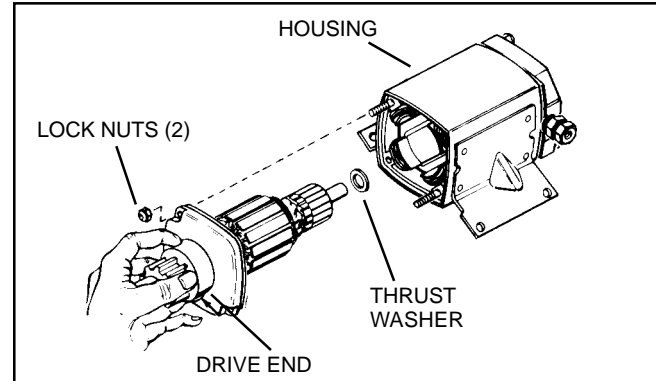

- Remove dust cover, retaining ring, spring retainer, anti-drift spring, gear and engaging nut. Remove drive end cap from armature.

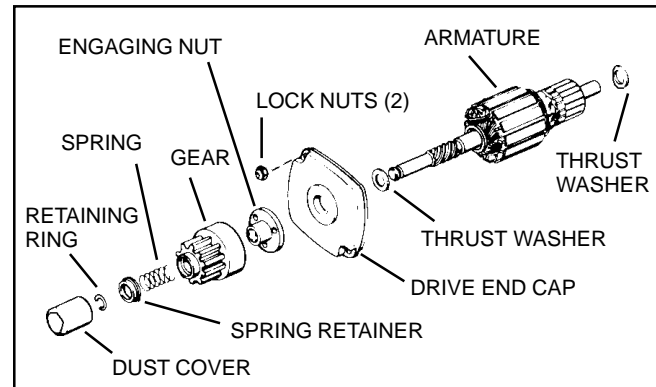

- To remove end cap assembly, loosen the nut on terminal post. Remove the lock nuts and thru bolts from starter housing. Remove brushes or brush card separately or as an assembly.

NOTE: Care must be taken in removing and reinstalling brush springs to eliminate damage to spring and malfunction of brushes.

3. Inspection

Inspect, clean and replace parts if necessary. Test motor parts for open and shorted circuits.

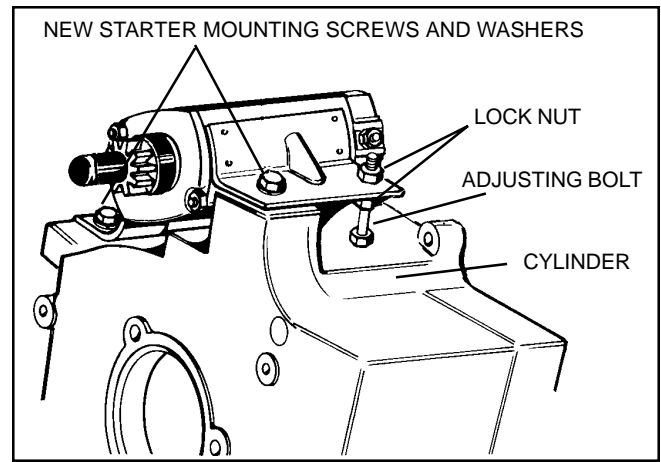
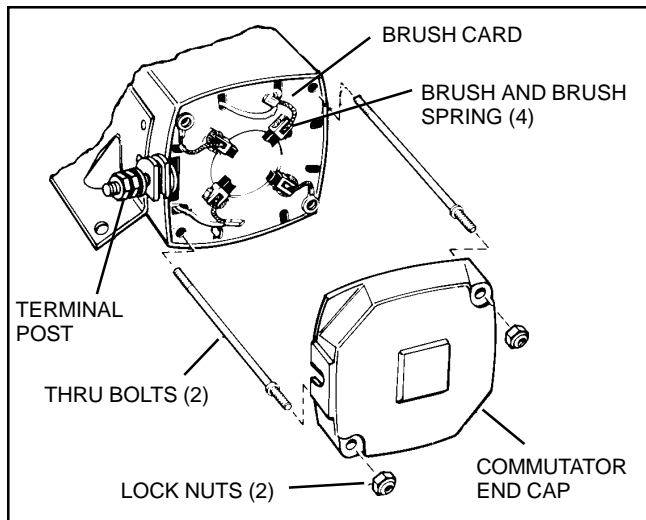

STARTER MOTOR TESTS

4. Assembly

- a. Install drive end cap, engaging nut and gear, anti-drift spring, spring retainer, retaining ring, and dust cover to armature. Install armature into housing.
- b. Install brush card assembly and two (2) thru bolts so stops on bolts will secure brush card. Secure lock nuts on drive end of starter.
- c. Install thrust washer on armature and install commutator end cap. Insure that the two-piece grommet is properly installed to prevent moisture from entering this area.
- d. Install end cap lock nuts.

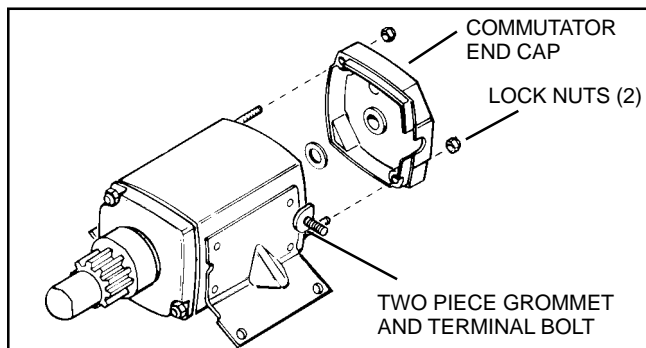

When using starter motor, part no. 33835 to replace starter part no. 32817 on vertical crankshaft models, proceed as follows.

1. Remove the two (2) 5/16-18 x 7/8" (22.225 mm) screws that attached the original starter and discard.
2. Install the 5/16-18 x 1-3/8" (34.925 mm) adjusting bolt through the hole in the starter bracket with a lock nut on each side of the bracket. Position bolt so head will not touch cylinder when starter is installed.
3. Install motor with two (2) 5/16-18 x 5/8" (115.875 mm) screws and lockwashers. Torque screws to 140-170 inch lbs. (18.2 - 19.2 Nm).
4. Turn adjusting bolt so head of bolt securely bottoms on cylinder. Tighten nuts to hold bolt in position.

a. Preliminary Tests

Before checking the starter motor perform the following preliminary checks:

1. Battery must be at least 3/4 full charge.
2. Determine parts such as switch, solenoid, between power source and starter motor are in good working order.
3. Terminals must be bright and clean for full conductance.
4. Check wires for breaks, insulation breakdown.
5. Proper size (gauge) wire between power source and starter motor.
6. If starter motor does engage the flywheel but fails to crank engine, check the engine for excessive friction caused by a seized rod or piston.
7. Check related parts such as clutches, pulleys, etc. for excessive friction.

b. Visual Checks

Make a visual check of the starter motor before checking electrically. Remove the starter motor and check for freedom of operation by turning the shaft. Look for:

1. Worn out brushes.
2. Weak brush springs.
3. Dirt on the commutator bars.
4. Armature binding, caused by dirt or bushings being gummed up through excessive lubrication.

STARTER CHECKING AND SERVICE. Remove nuts at both ends of starter and take off rear end cap.

CHECK FIELD. Using a continuity light or ohm meter, check field by attaching one lead to each field coil connection. Continuity should exist between these two points. Check continuity between each field coil connection and the starter housing. No continuity should exist.

ARMATURE CHECK. If commutator bars are glazed or dirty they can be turned down in a lathe. While rotating, hold a strip of 00 sandpaper lightly on the commutator, moving it back and forth. (Do not use emery cloth). Recut grooves between commutator bars to a depth equal to the width of the insulators.

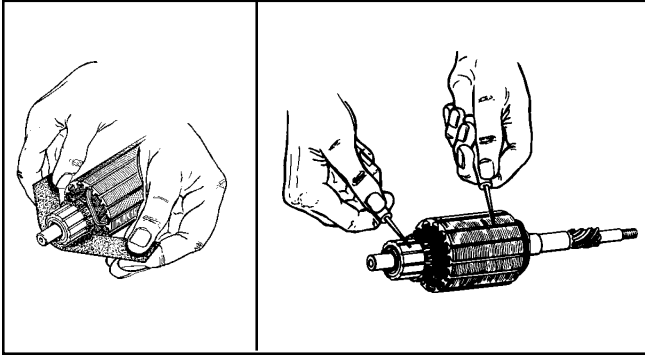

Using a continuity tester to make certain no continuity exists between the commutator (copper) and the iron of the armature, rotate armature and check out all commutator bars.

The armature can be thoroughly checked with a growler if available.

CHECK BRUSHES. Before removing armature, check brushes for wear. Make sure brushes are not worn to the point where the brush wire bottoms out in the slot of the brush holder. Brush springs must have enough strength to keep tension on the brushes and hold them against the commutator.

If brushes need replacement, remove by unhooking terminals or clipping connections and resoldering. If brush card is warped from overheating, replace the brush card assembly.

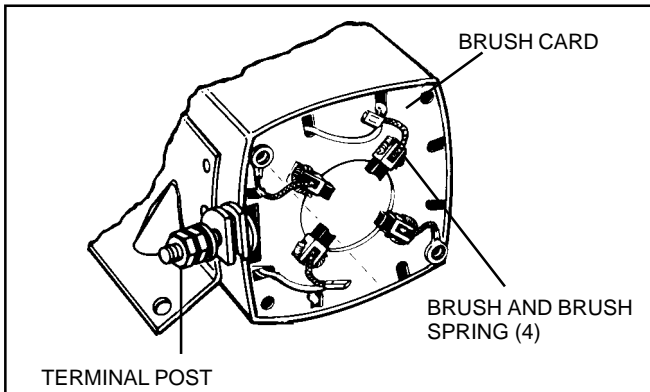

INSTRUCTIONS FOR REPLACING STARTER BRUSH CARD #33848 ON STARTER #33835

1. Loosen the two nuts on the starter terminal post, but do not remove.
2. Remove the nuts holding the starter and cap in place. Remove the starter end cap. Note the thrust washer on the end of the armature.

3. With a pliers or vise grip tool, grasp the through-bolts as close to the flanged end as possible (away from the threaded end), and remove the two nuts retaining the driving end cap of the starter. Remove the armature and driving cap assembly. Remove the two through-bolts, noting the position of the brush ground eyelet under the through-bolt flange.
4. Note the position and the connections of the brush wires. Clip the solid field wires as close to the connectors as possible.
5. Remove the brush card from the starter, noting the position of the clearance slot. Clean the starter and all parts of accumulated dust and dirt. Scrape the insulating varnish off of the solid field wires, back approximately 1/2" (12.7 mm) from ends.
6. Insert the new brush card into position, guiding the solid field wires through the proper slots in the brush card.
7. Using the proper crimp connector, crimp and solder the remaining brush leads to the solid field wires. Use a pair of pinchers or needle-nose pliers to hold the woven brush lead adjacent to the connector while soldering (this provides a heat sink so that solder does not flow up the brush lead). Using electrical tape or shrink tubing, insulate the crimped connection nearest the starter terminal post. Position the wires to prevent shorts or grounding of the starter.
8. Spread the brushes to install the armature into the housing, and replace the starter through-bolts, being sure to install them through the ground brush eyelet terminals. Install and tighten the drive end through-bolt nuts. Tighten securely, but do not over tighten as this may warp the new brush card and impair brush movement.
9. Replace the thrust washer on the end of the armature and replace the starter end cap. Install the starter end cap locking nuts and tighten securely. Tighten the nut on the starter terminal post.
10. Test the starter for proper operation before reinstallation on the engine.

SECTION 3

12 VOLT STARTER TROUBLE SHOOTING CHART

PROBLEM	PROBABLE CAUSE	FIX
Does not function	<p>Weak or dead battery</p> <p>Corroded battery terminals and/or electrical connections</p> <p>Brushes sticking</p> <p>Dirty or oily commutator</p> <p>Armature binding or bent</p> <p>Open or shorted armature</p> <p>Shorted, open or grounded field coil</p> <p>Loose or faulty electrical connections</p> <p>Load on engine</p> <p>Electric starter cranks but no spark at spark plug.</p> <p>Electric starter does not crank engine</p>	<p>Check charge and/or replace battery.</p> <p>Clean terminals and/or connections.</p> <p>Free brushes. Replace worn brushes and those that have come in contact with grease and oil.</p> <p>Clean and dress commutator.</p> <p>Free armature and adjust end play or replace starter.</p> <p>Replace starter.</p> <p>Replace starter.</p> <p>Correct.</p> <p>Disengage all drive apparatus and relieve all belt and chain tension.</p> <p>Disconnect ignition cutoff wire at the engine. Crank engine. If spark at spark plug ignition switch, interlock switch and safety switch is inoperative. If no spark, check magneto. Check wires for poor connection cuts or breaks.</p> <p>Remove wire from starter. Use a jumper battery and cables and attach directly to starter. If starter cranks engine the starter is okay; check solenoid, starter switches, safety switches and interlock switches. Check wires for poor connections, cuts or breaks.</p>
Low RPM	<p>Unit controls engaged</p> <p>Worn bearings in cap assemblies</p> <p>Bent armature</p> <p>Binding armature</p> <p>Brushes not seated properly</p> <p>Weak or annealed brush springs</p> <p>Incorrect engine oil weight</p> <p>Dirty armature commutator</p> <p>Shorted or open armature</p> <p>Loose or faulty electrical connections in motor</p>	<p>Insure all unit controls are in neutral or disengaged.</p> <p>Clean bearings or replace cap assemblies.</p> <p>Replace starter.</p> <p>Free up armature. Adjust armature end play.</p> <p>Correct.</p> <p>Replace springs.</p> <p>Insure the correct weight of oil is being used.</p> <p>Clean commutator.</p> <p>Replace starter.</p> <p>Correct.</p>
Motor stalls under load	<p>Shorted or open armature</p> <p>Shorted field coil</p>	<p>Replace starter.</p> <p>Replace starter.</p>

CHAPTER 4. GENERAL VALVE INFORMATION, CYLINDER HEAD AND BREATHER ASSEMBLY

SECTION 1. GENERAL VALVE INFORMATION

Adjusting valves for 8 horsepower and larger engines (except valve-in-head engines)

Intake valve gap .010, (.254 mm) exhaust valve gap .020, (.508 mm) set when engine is cold. Rotate the engine to Top Dead Center of the compression stroke, this will assure that the lifter is not raised by the compression relief pin. Valve stem ends must be ground flat when adjusting valve gap. An uneven or concave end can cause abnormal wear to the valve train.

The outside of the valve stem guide also guides the valve spring. A valve spring cap is used only on the bottom of the spring. A pin through the valve stem retains the spring.

Use a step type reamer to enlarge valve guides if worn. Oversize valves are 1/32" (.787 mm) larger in diameter than standard. (For oversize reamer, Consult Chapter 11).

Do not enlarge the valve lifter guide, lifters with oversize stems are not available.

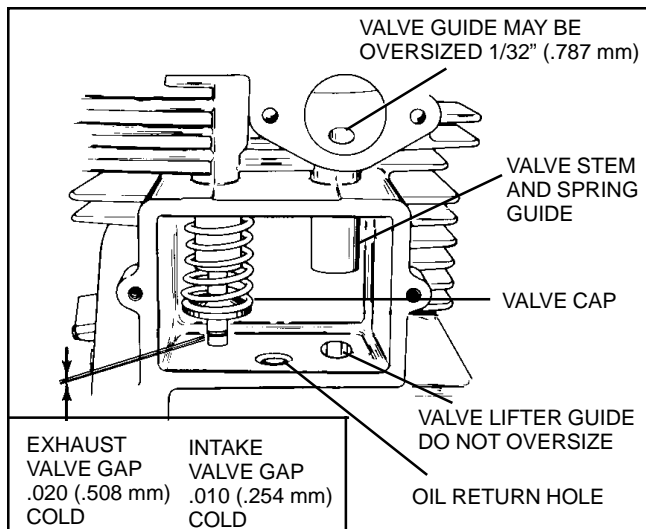

ADJUSTING VALVES ON OVERHEAD VALVE ENGINES. Remove the breather and top half of the valve cover. Rotate the engine to Top Dead Center of the compression stroke. Adjust the exhaust valve to .010 (.254 mm) and .005 (.127 mm) for the intake valve.

Assure that the locknut is loosened before attempting to turn adjusting screw. After the locknut is loosened, turn the adjusting screw with an open end wrench. Turn adjusting screw clockwise to decrease clearance and counterclockwise to increase clearance.

TURN ADJUSTING SCREW: CLOCKWISE TO DECREASE LASH, COUNTERCLOCKWISE TO INCREASE LASH.

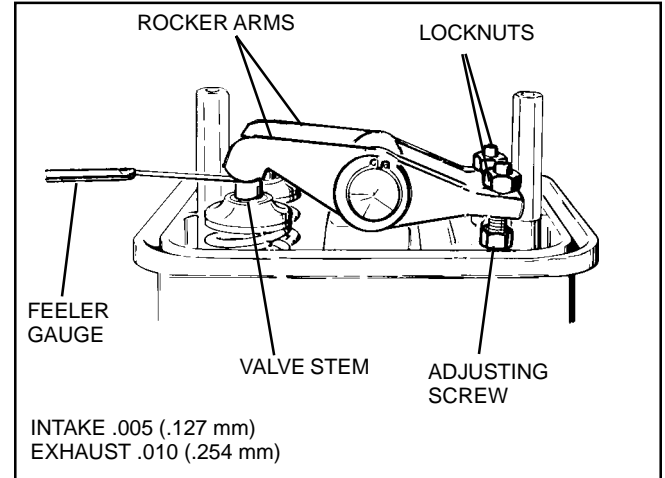

VALVES. Valves must be in good condition, properly sealing and the proper gap must be maintained for full power, easy starting and efficient operation.

VALVE REMOVAL On 8 H.P. and Larger (except valve overhead engines). To remove valves, raise the lower valve spring caps, while holding the valve head tightly against the seat, and remove pin.

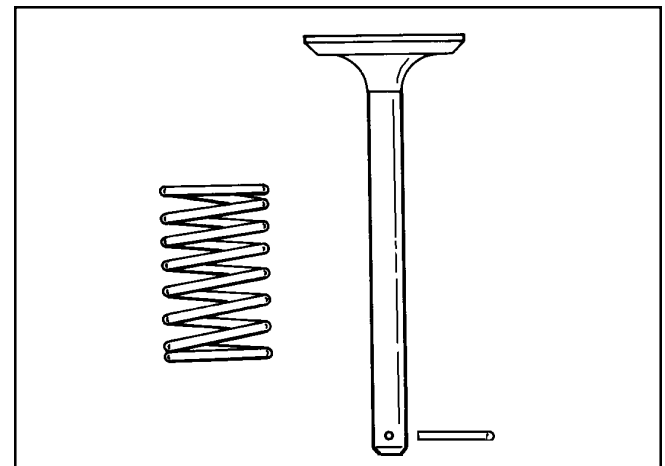

VALVE REMOVAL PROCEDURE FOR VALVE-IN-HEAD ENGINES.

The following is necessary for cylinder head disassembly.

REMOVAL OF ROCKER ARM HOUSING PARTS.

Locate the piston at top dead center for easier access in servicing the valve train. After removing the rocker arms by removing the retaining rings, it may be necessary to loosen the locknut and back off the adjusting screw before pulling off the rocker arms. NOTE: Rocker arm shaft is not an inseparable unit from the rocker arm housing and should not be removed from the housing.

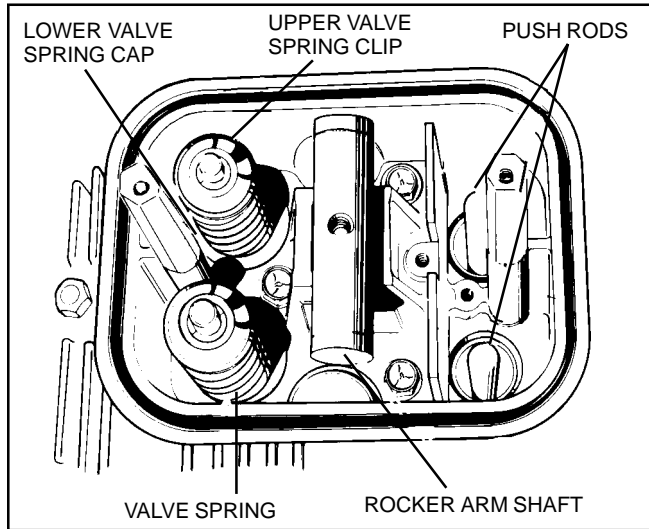

REMOVAL OF ROCKER ARM HOUSING. Remove rocker arm housing by removing the retaining cap screws. The valve spring retainer cupped side must be facing in the up position.

A white Teflon "O" Ring is used under the valve spring retainer on the exhaust valve. The regular black rubber "O" Ring is used under the valve spring retainer on the intake valve. Be careful not to switch rings, or damage may result.

Remove head to remove the valves - Reverse procedure for reassembly.

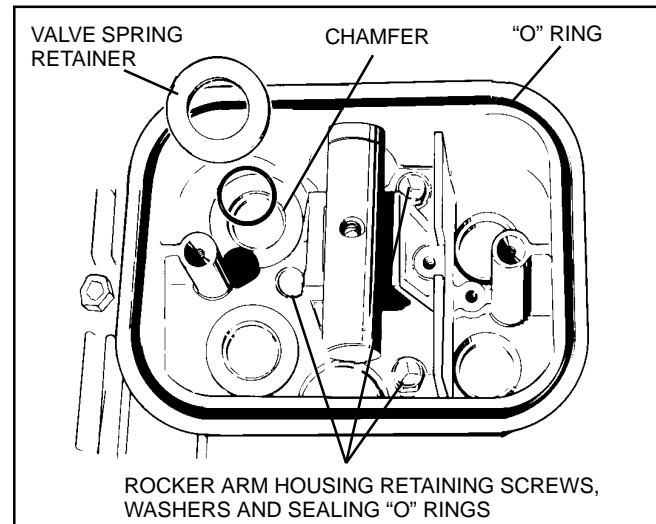

ROCKER ARM SHAFT. The rocker arm shaft is not a replaceable part. The rocker arm housing, rocker arm shaft and screw are an inseparable assembly.

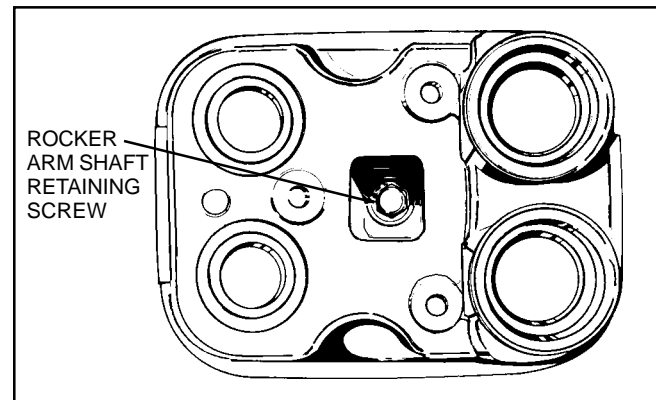

REMOVAL OF VALVE SPRINGS. Use a valve spring compressor tool, part No. 670237A to compress the valve spring and remove the valve retainers. Be sure piston is at T.D.C. The valve cap is then taken off for removal of the spring. When reinstalling the valve cap and retainers after valve servicing, it may be necessary to hold both valves in their seats until the springs, cap, and retainer have been installed on the valve stems. Access can usually be gained through the exhaust and intake manifold in the head.

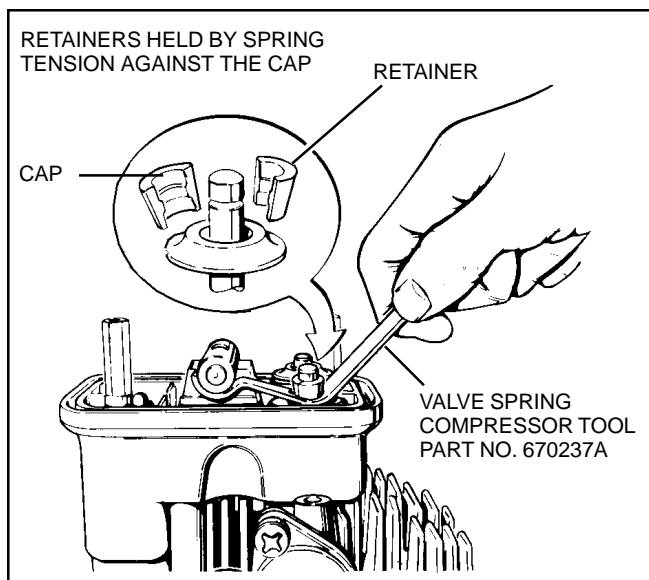

VALVE SPRINGS FREE LENGTH FOR 8 HORSEPOWER AND LARGER ENGINES (EXCEPT VALVE-IN-HEAD ENGINES). Valve springs should be replaced when an engine is overhauled. Weak valve springs will spoil the best overhaul job.

Valve spring free length should be checked. Comparing one spring with the other can be a quick check to notice any difference. If a difference is noticed, carefully measure free lengths and strength of each spring. See specifications.

Check valve spring free length, it should be 1.885" (47.879 mm). If both ends are not parallel, replace with new springs.

VALVE INSTALLATION. To reinstall valves, position valve caps and spring in the valve compartment. Valve spring free length should be checked and installed so the dampening coils are located opposite the keepers.

INSTALL PIN Release valve spring tension to lock cap in place.

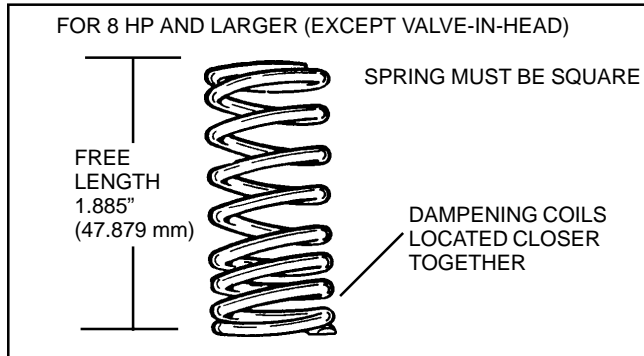

DAMPENING COILS ON VALVE SPRINGS. The valve spring should be assembled so the dampening coil is located to the stationary end of the spring (opposite the cap and retainers).

VALVE-IN-HEAD SPRINGS. Check valve spring free length, it should be 1-15/16" (49.225 mm) long. If both ends are not parallel, replace with new springs.

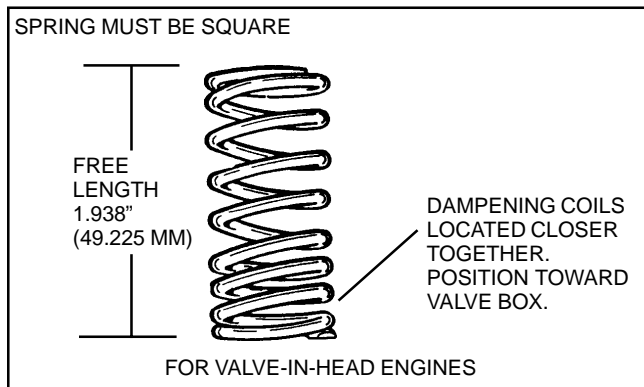

VALVE GRINDING. Valve grinding procedures are the same for all 8 horsepower and other engines. (Including overhead valve engines). See Chapter on specifications.

Correct valve grinding procedures are essential to obtain a satisfactory result.

Face and seat angles must be accurate and the surfaces must be smooth.

A 1/32" (.787 mm) margin must be left on the valve head after refacing. The valve without a margin would burn and distort very rapidly.

Use a "Vee" block and the flat side of a grindstone to grind valve clearance. The end of the stem must be flat and true or abnormal wear will occur.

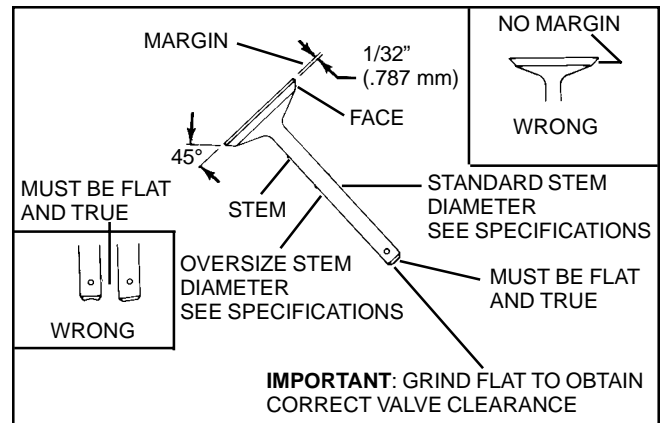

VALVE SEATS. Valve seats are not replaceable. If they are burned or pitted, they can be recut using a Neway valve and seat cutter. Seats are cut to an angle of 46°. If the seat is over 3/64" (1.194 mm) wide after cutting, use a 30° cutter to narrow the face.

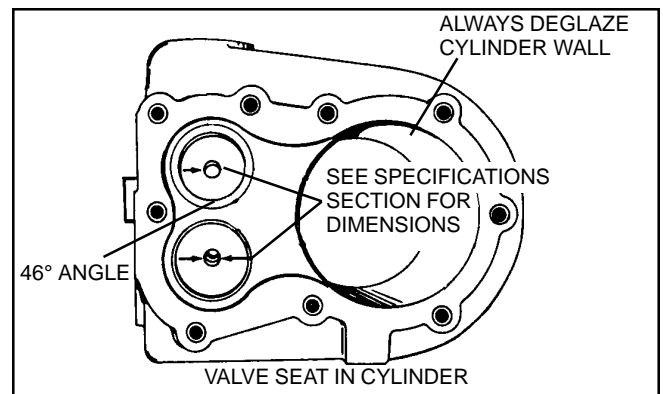

VALVE SEAT CUTTING REQUIREMENTS. Cut valve seats to 46° and valve to 45°. See Specifications.

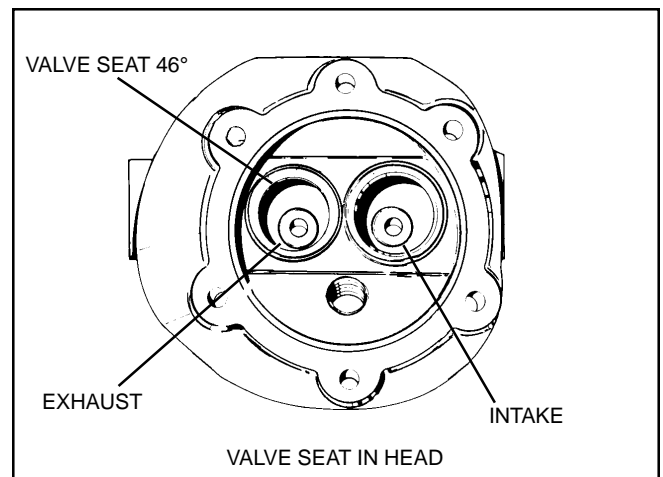

VALVE GUIDE DIMENSIONAL CHECK. Check dimensions per specification requirements, determine if valve guide clearance is beyond acceptable tolerance. If valve guide clearance is worn beyond tolerance, ream valve guide oversize and install 1/32" (.787 mm) oversize valve, or replace valve guides.

! THIS SYMBOL POINTS OUT IMPORTANT SAFETY INSTRUCTIONS WHICH IF NOT FOLLOWED COULD ENDANGER THE PERSONAL SAFETY AND/OR PROPERTY OF YOURSELF AND OTHERS. READ AND FOLLOW ALL INSTRUCTIONS.

VALVE GUIDE REMOVAL AND INSTALLATION INSTRUCTION FOR VALVE-IN-HEAD ENGINES.

REMOVING THE OLD VALVE GUIDES

1. Submerge the head in a pan of oil so that both guides are covered with oil.
2. Heat oil on a hot plate until the oil begins to smoke. About 15 to 20 minutes. 375° (190°C) - 400° (204°C).
3. When the oil begins to smoke, remove the head from the pan of oil with a pair of pliers. Drain excess oil.
4. Place head on the bed of an arbor press on parallels with the snap rings on the long ends of the guides facing down.
5. Use a 1/2" (25.4 mm) diameter, 6" (152 mm) drift-punch and the arbor press to push valve guides out of the head.

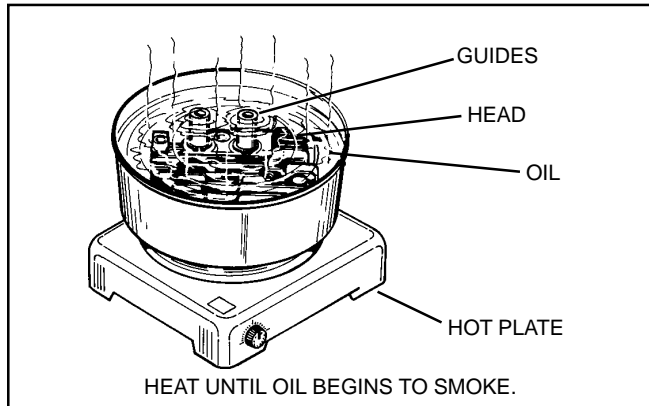

CAUTION - When locating the drift punch on the guides be sure to center the punch. DO NOT allow the punch to make contact with the head when pressing out the guides.

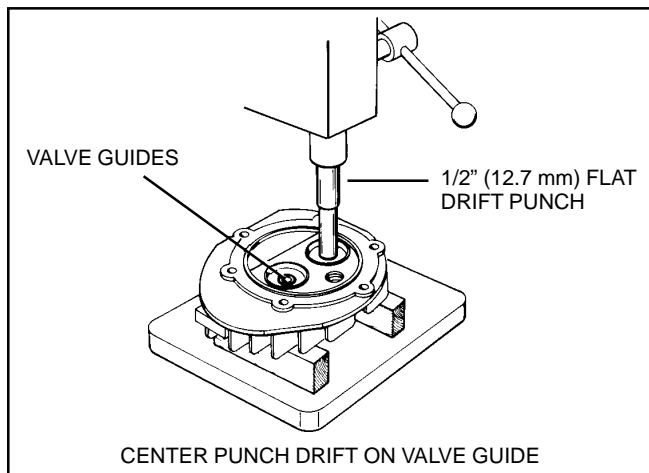

INSTALLING NEW GUIDES

NOTE For easy installation, the replacement guides should be placed in the freezer compartment of a refrigerator or on ice for no less than 30 minutes prior to installation.

1. Submerge head with guides removed in a container of oil so that both guide bores are covered with oil.
2. Heat oil on a hot plate until the oil begins to smoke. About 15 to 20 minutes.
3. When the oil begins to smoke, remove the head from the pan with a pair of pliers. Drain excess oil.
4. Place head, with gasket surface down, on a piece of wood, 6 x 12 inches (152 X 304 mm).
5. Remove the new guides from cold storage and install snap rings used for locating both valve guides. Insert the guides. It may be necessary to use a rubber or rawhide mallet to fully seat the guides to the snap ring depths in the head. DO NOT use a metal hammer head, or guide damage will result.
6. Allow head assembly to cool; recut both valve seats.

SECTION 2. CYLINDER HEAD

CYLINDER HEAD TORQUE. For 8 H.P. and larger engines (except valve-in-head engines), make sure surfaces are clean, then place new head gasket on cylinder and position head.

Slide one belleville washer (crown toward bolt head) and one flat washer (sharp edge toward bolt head) over each bolt as shown in illustration.

Insert the bolts in the head with the two shorter bolts in the position shown in the illustration. The two short bolts for positions 1 and 8 are 2" long (50.8 mm) and all other bolts are 2-1/4" long (57.15 mm).

Tighten bolts evenly to 50 in. lbs. (5.6 Nm) torque. Increase torque evenly by 50 in. lbs. (5.6 Nm) until final torque of 200 in. lbs. (22.6 Nm) is attained in the following sequence: (See Figure)

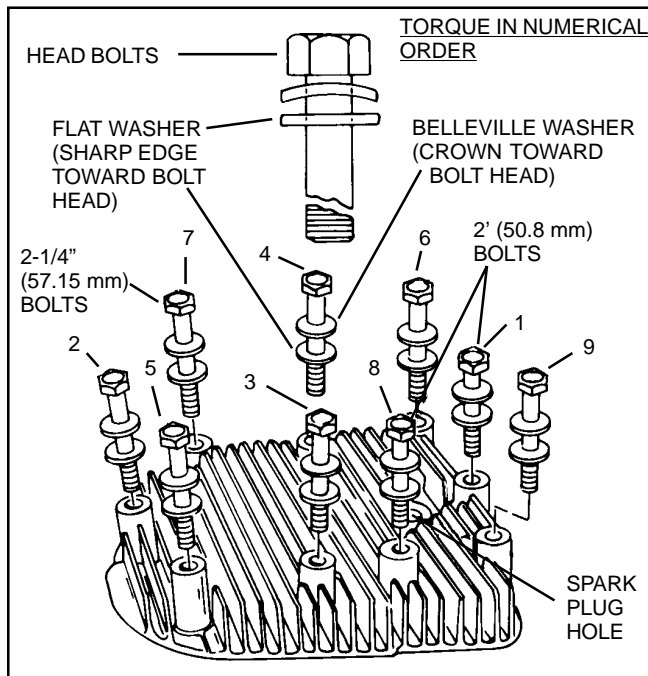

Run engine for 15 minutes, allow to cool and then retorque the bolts in the same sequence as described above.

CYLINDER HEAD TORQUE FOR VALVE-IN-HEAD ENGINES.

Slide one belleville washer (crown toward bolt head) and one flat washer (sharp edge toward bolt head) over each bolt as shown in illustration.

Torque head bolts to 200 inch pounds (22.6 Nm) in 50 inch pound (5.6 Nm) increments. Tighten in numerical order. Note that head bolts marked 1 and 5 are 1-3/8" long (34.925 mm). Other bolts are 1-3/4" long (44.45 mm).

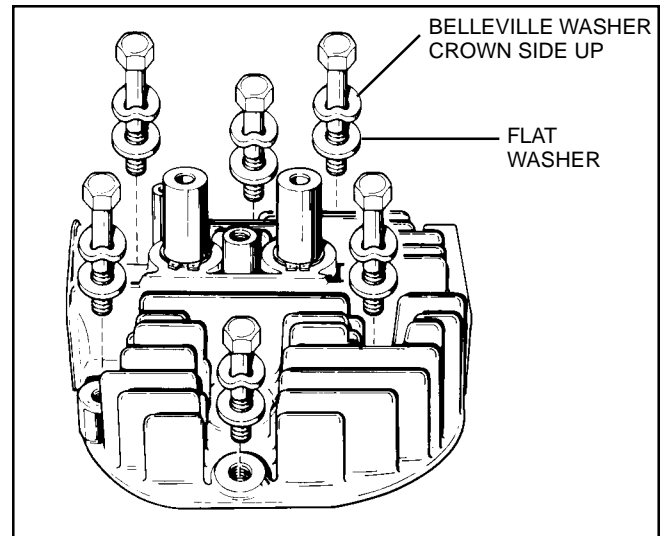

HEAD ASSEMBLY, TORQUE SPECIFICATIONS. Run engine for 30 minutes, allow to cool until head is cool to the touch and then retorque the bolts in the same sequence as described. (All except number "1" (25.4 mm) bolt which cannot be retorqued unless the rocker arm housing is removed.)

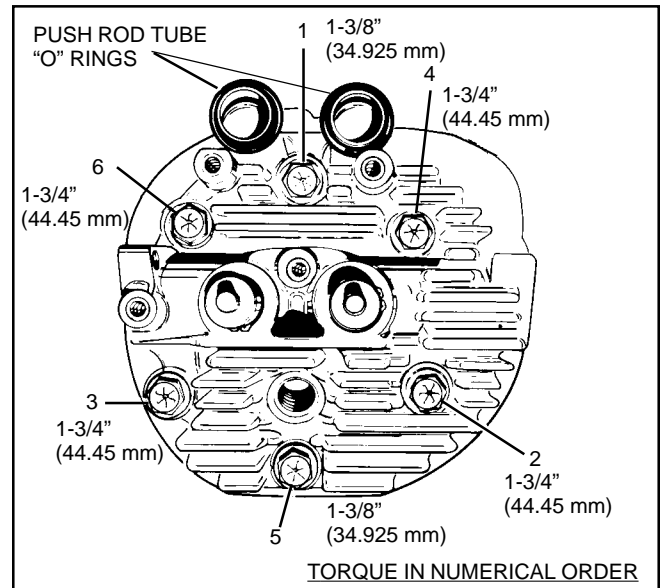

SECTION 3. BREATHER ASSEMBLIES

The Breather is a sealed assembly. If it is defective, replace the entire assembly. The rubber tube on the outside is not part of the assembly.

Install the breather with the drain holes toward the base of the engine. Always use a new gasket. The retaining screws must be tight.

If oil is being pumped out the breather:

1. Check for excess speed.
2. Operating at excessive angles.
3. Loose oil filler cap.
4. Worn rings.
5. Excess blow-by.
6. Breather body installed up-side down.
7. Overfilled with oil.

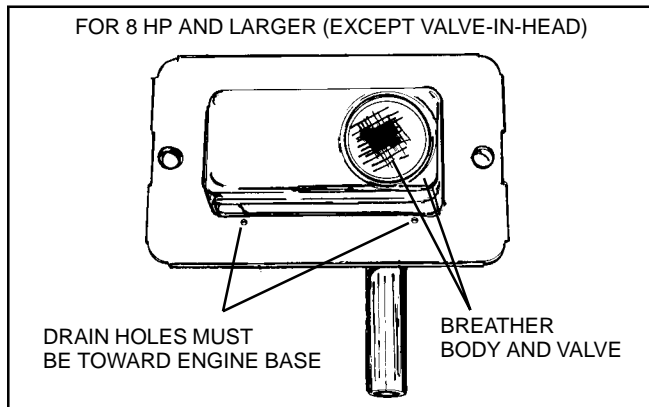

FOR VALVE-IN-HEAD ENGINES

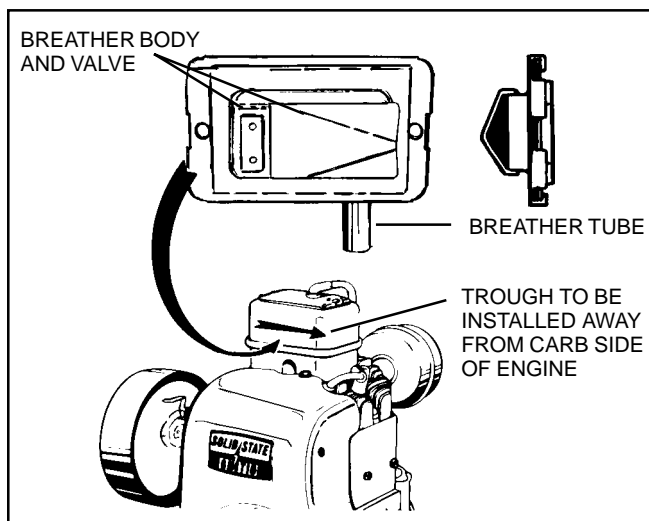

CHAPTER 5. PISTON AND RINGS, CONNECTING RODS AND CRANKSHAFTS

SECTION 1. PISTON AND RINGS

PISTON AND RING DISASSEMBLY. Always remove ridge and carbon buildup before attempting to remove the piston and ring assembly from the cylinder.

Always deglaze the cylinder when replacing the piston and rings. This must be done to allow the rings to seat.

Make sure surfaces are clean, then place new head gasket on cylinder and position head.

Always use a new head gasket if the cylinder head has been removed.

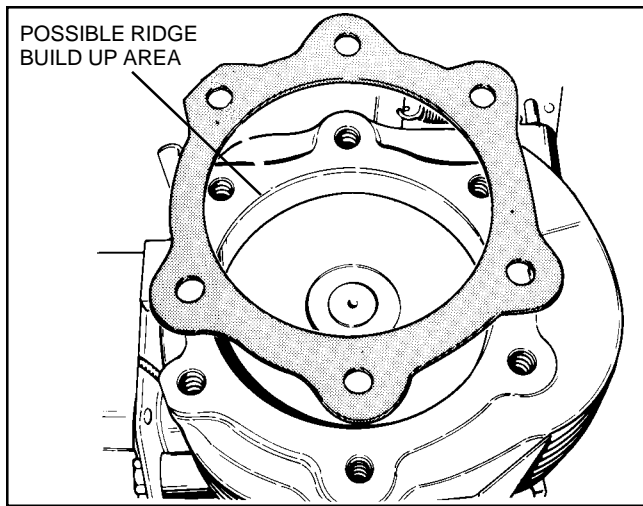

RING AND WRIST PIN ASSEMBLY. Stagger the piston ring gaps 90° apart when installing piston and ring assembly in cylinder.

The wrist pin retainers must be seated in the groove. Move the wrist pin if necessary. Failure to correctly seat the retainers may result in costly repairs.

The wrist pin is a palm press fit (pressed in by hand with some resistance). If loose, check connecting rod for seizing. Replace piston and wrist pin if loose.

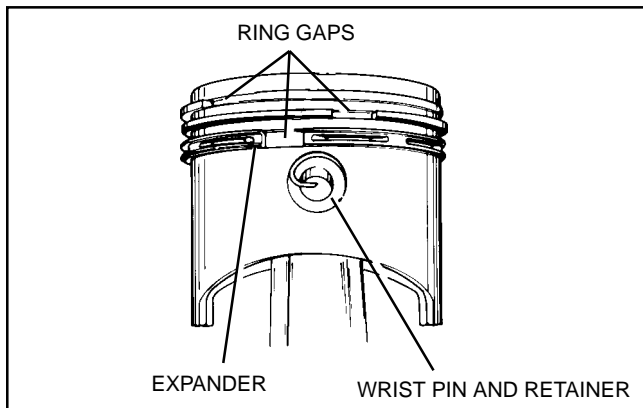

RING GROOVE CHECK. Check the side clearance of the ring in the groove using a feeler gauge. If excessive, replace the piston. See Specifications.

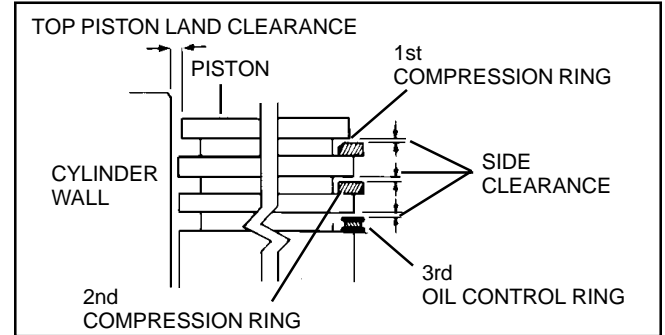

PISTON DIAMETER MEASUREMENT. Check piston diameter on the bottom of the skirt. Check at 90° to center line of wrist pin hole. This is a cam ground piston and the diameter will not be the same when checked at another point.

Pistons and rings may be available in either .010" (.254 mm), .020" (.508 mm), .030" (.762 mm) and .040" (1.016 mm) oversize.

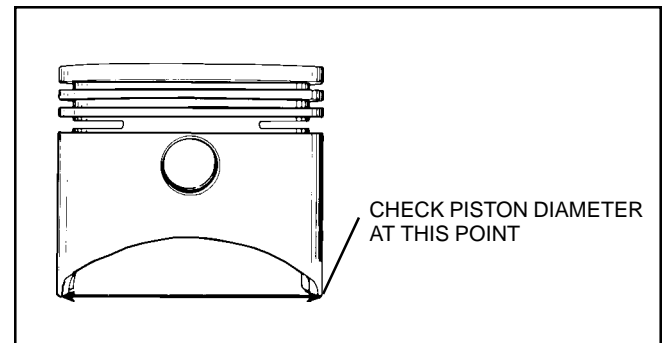

RING END GAP MEASUREMENT. Before installing the rings, insert each ring into the cylinder bore to check the end gap. This gap check should be made in a worn cylinder, a reconditioned cylinder and a new cylinder.

An inverted piston should be used to push the ring into the cylinder to a point that would be the center of ring travel. The ring travel area will be the most worn area in a used cylinder. Insert the piston ring into the cylinder and place the top side of the piston on the ring to position the ring squarely in the bore; remove piston. Measure the end gap by inserting a feeler gauge between the ring ends. Check each ring using the same procedure.

The end gap dimensions are shown in the specification division of this manual. If end gap is greater than the maximum specification, then the cylinder must be measured and perhaps bored oversize. If the end gap is too small, carefully remeasure the bore for undersize dimension and enlarge if necessary.

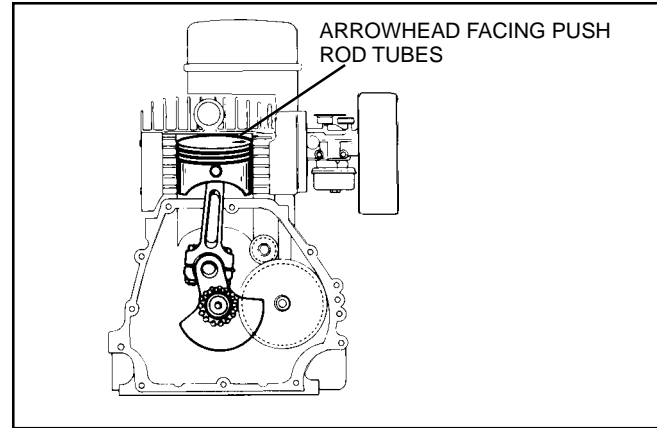
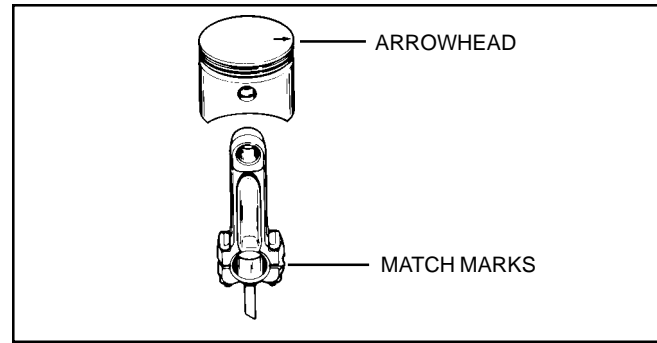
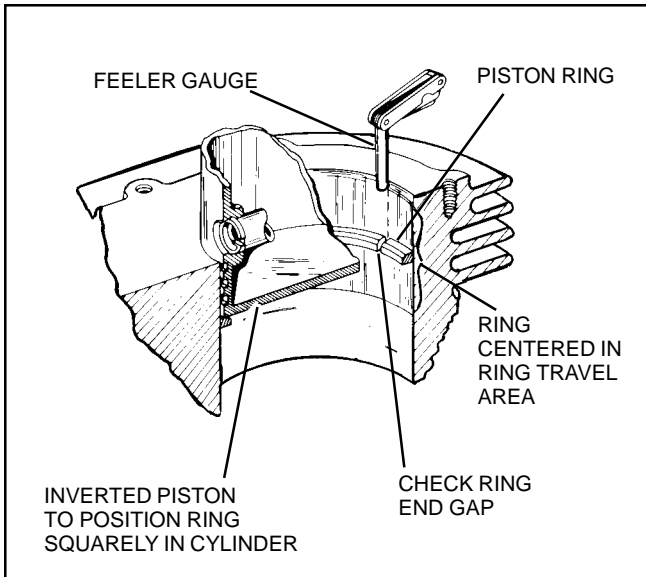

PISTON RING INSTALLATION. Only correct piston ring installation will assure full power. Carefully note the ring sequence when removing the worn rings from the piston. Note especially the ring expander, as it may be found both behind the second (compression) ring and the third (oil control) ring.

Although piston rings are installed correctly, they will not perform unless the piston and cylinder are reconditioned. Clean and check the ring grooves for wear. Deglaze the cylinder bore with a fine abrasive cloth; this will aid in the seating of the rings.

When reinstalling the rings, note the marks on the first and second rings in dictating the top of the ring. Stagger the ring end gaps to prevent compression loss. Use plenty of service classification SF - SJ rated oil to lubricate all friction surfaces during engine reassembly.

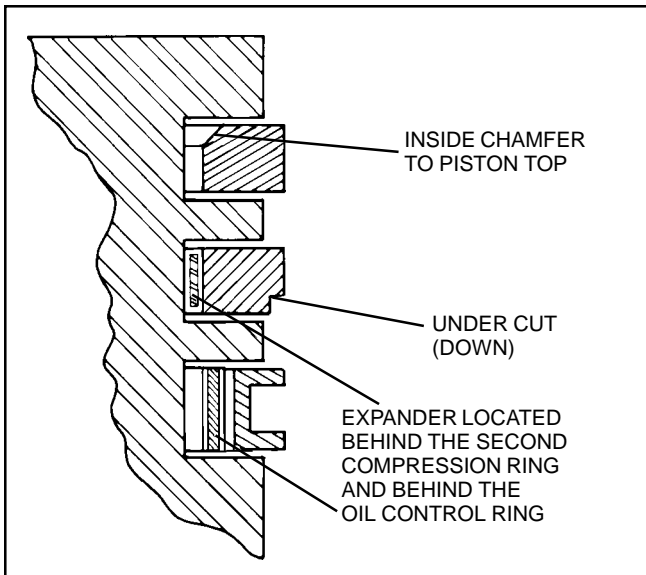

OFFSET PISTON INSTALLATION FOR OH180 VALVE OVERHEAD ENGINE. The connecting rod is assembled to the piston with match marks facing the mechanic and the arrowhead on the piston pointing to the right i.e., arrowhead facing the push rod tube area.

SECTION 2. CONNECTING RODS

When reinstalling a used connecting rod ALWAYS use new nuts on the bolts. These locking nuts will ensure that the torque will be retained when the connecting rod is replaced.

The connecting rod must be installed with the match mark facing out of the cylinder, toward the P.T.O. end of the crankshaft. This will ensure the correct positioning of the oil dipper. Install as illustrated.

The heads of the through bolts must be seated tight against the machined shoulder on the connecting rod. Failure to check this may result in a false torque reading and premature failure.

IMPORTANT Torque to correct specifications. 110 inch pounds (12.43 Nm).

NOTE Before installing, clean the connecting rod bearing surfaces with a clean cloth. Rods are coated with lead which will slightly oxidize in storage, this oxidation must be removed.

FOR ENGINE MODELS HH80, HH100 and HH120 and VALVE-IN-HEAD ENGINES.

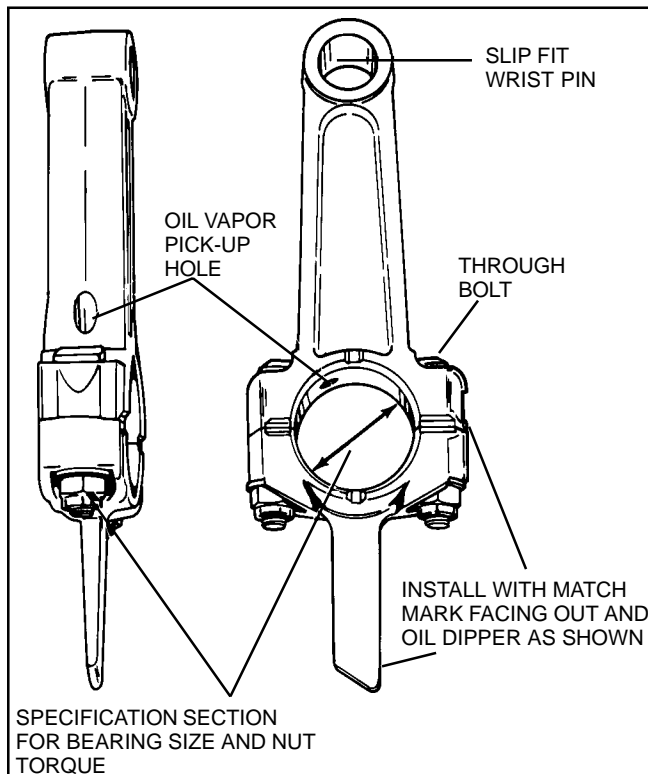

The vertical crankshaft 8 and 10 H.P. engines have a connecting rod with two lube holes. This rod is not interchangeable with the horizontal connecting rod. The above requirements listed for a horizontal crankshaft rod also apply to the vertical crankshaft engines connecting rod.

FOR ENGINE MODELS VH80 and VH100

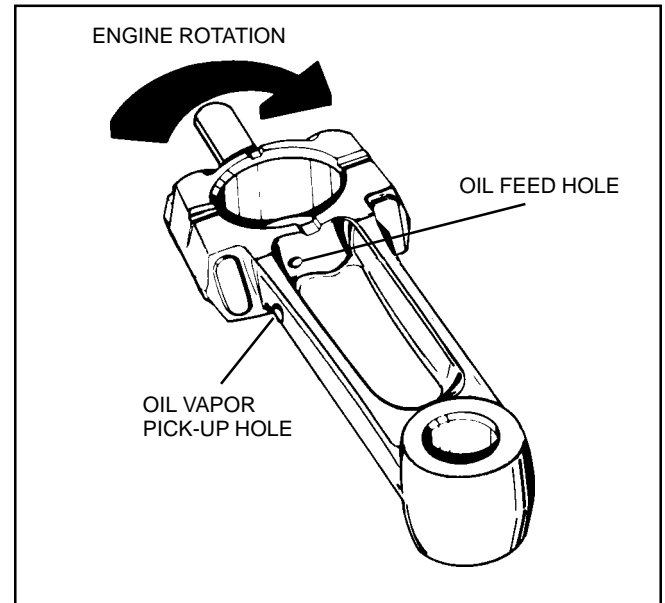

Torque to correct specifications 110-inch pounds (12.43 Nm). After initial torque use a drift and a hammer (13 oz.) (390 ml) and strike the rod bearing cap above each lock nut. This will seat the cap releasing some torque on the lock nuts. Retorque lock nuts to specifications.

SECTION 3. CRANKSHAFTS

CRANKPIN WEAR. Crankpins should be examined for wear, scoring, or out of-round. If any of these conditions are noted, replace the crankshaft. See specifications.

Lubricate the crankpin generously before attaching the connecting rod. This will prevent damage during the initial run-in after reassembly.

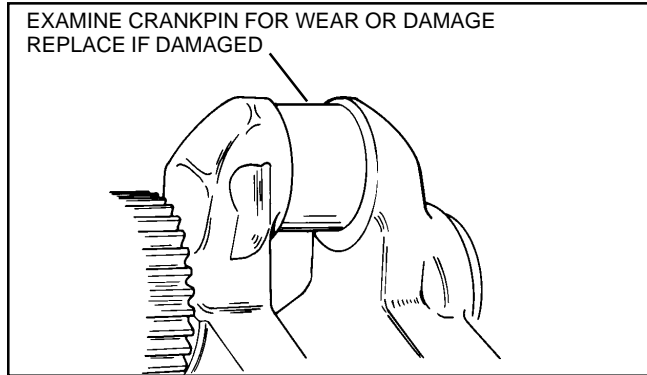

The vertical VH80 and VH100 (without oil pump) oil slinger is located on the crankshaft. It is locked in position between the bearing and the crank gear and maintains that position due to a slot in the gear and a stamped bulge in the slinger. This alignment is necessary to direct the lubricant up into the engine at a closely engineered angle. Note the pickup trough and the stiffening rib. View B shows the trough alignment in correct relation to the crankcase journal. The slinger should not be incorrectly assembled 180° out of phase.

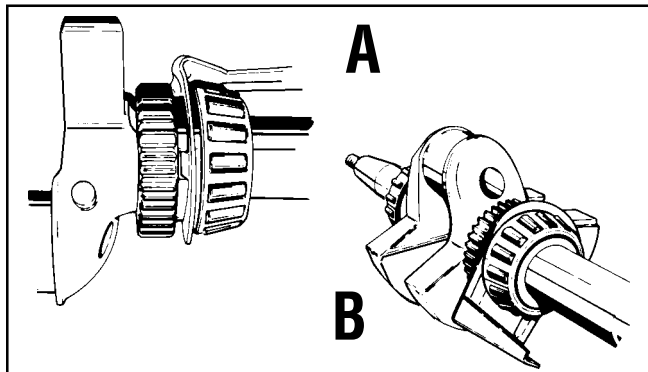

PLUNGER TYPE PUMP

Some vertical VH100 engines use a plunger-type oil pump to circulate lubrication. The oil is pumped up through a hole in the camshaft to a passage allowing the crankshaft and parts to be lubricated.

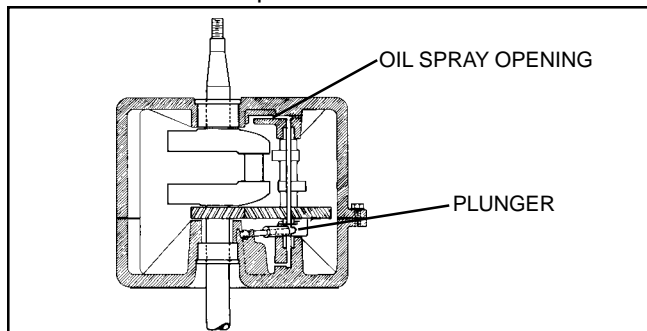

Note the chamfer tooth on the crankshaft gear. This tooth is used as a reference mark to be matched with the timing mark on the camshaft.

The crankshaft gear is replaceable. Remove gear with a conventional puller after the roller bearing has been removed. The gear and the bearing may be removed simultaneously, but much difficulty may be encountered.

Roller bearing must be heated before it is installed.

NOTE: If a damaged gear is replaced, the mating gear should also be replaced. Example: If the camshaft is damaged and replaced, the crankshaft gear should be replaced.

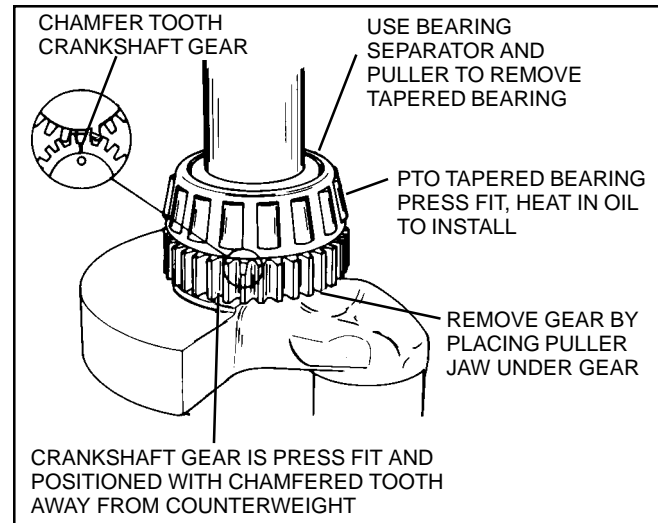

CRANKSHAFT GEAR INSTALLATION. Use an arbor press and suitable driver to press crankshaft gear into position. Keyway in crankshaft gear is to fit over gear pin and beveled tooth must face P.T.O. end of crankshaft. Crankshaft gear must fit tightly against shoulder.

On engines equipped with Dyna-Static, the counterweight balance gear is installed between the crankshaft gear, spacer and the bearing. Keyway in counterbalance gear is to fit over gear pin and beveled tooth is in line with keyway.

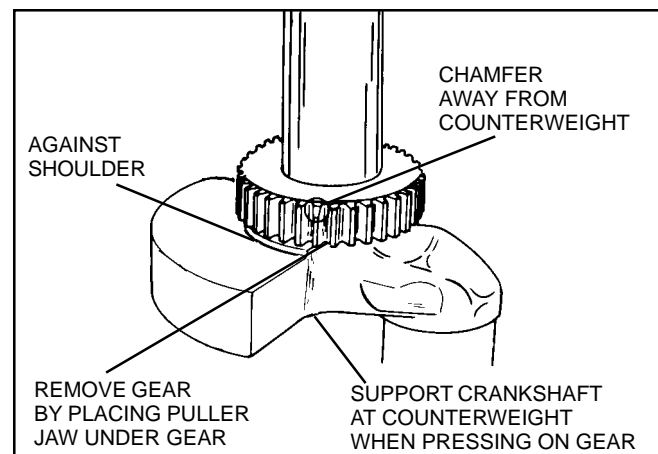

CHAPTER 6. CAMSHAFT, BEARINGS AND SEALS

SECTION 1. CAMSHAFT

CAMSHAFT GEAR TEETH WEAR. When servicing engines, check the camshaft at the points indicated by the asterisks in figure. Examine the gear teeth for wear and damage. See Specifications.

NOTE: If a damaged gear is replaced, the mating gear should also be replaced.

Example: If the camshaft is damaged and replaced, the crankshaft gear should be replaced.

MECHANICAL COMPRESSION RELEASE. Clean the mechanism in a conventional parts cleaner and dry thoroughly. Individual component parts are not available as service replacement and cannot be obtained from the factory. New replacement camshafts with the compression relief mechanism are available.

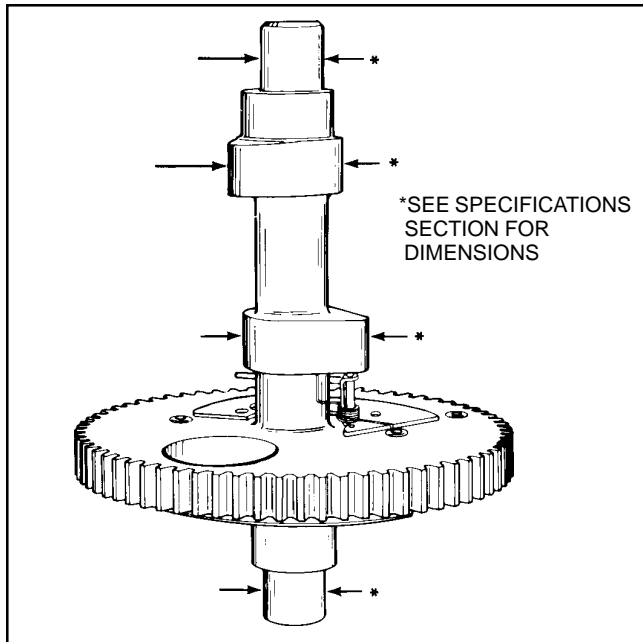

VALVE TIMING. Match chamfered gear tooth on crankshaft with mark and hobbing hole on camshaft gear.

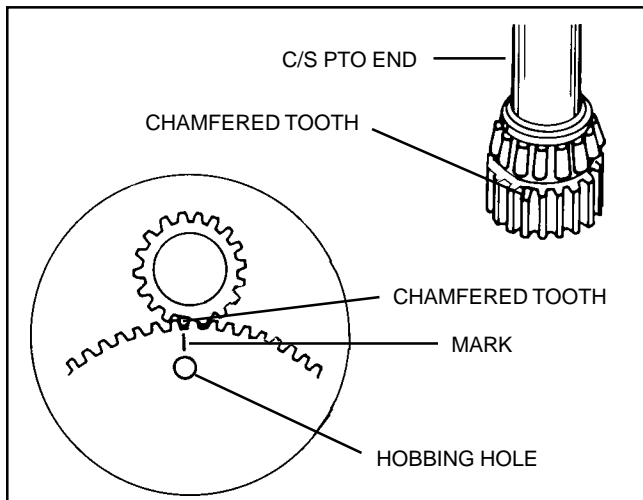

VALVE TIMING FOR ENGINE WITH HELICAL CUT GEARS.

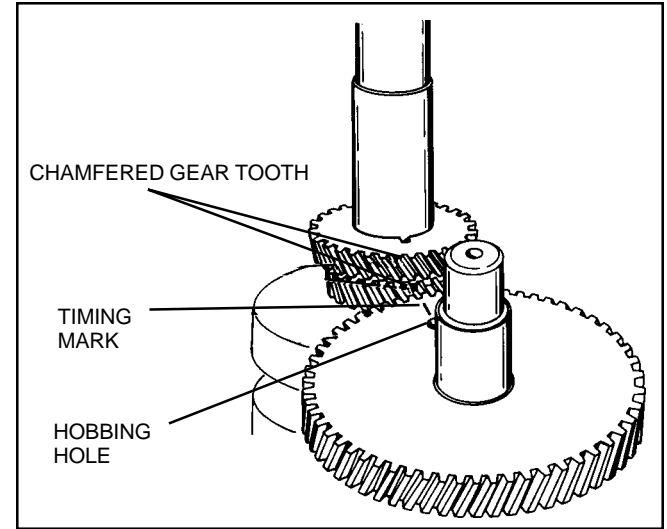

NOTE: When matching up helical gears, do so with a slight rotating motion of the crankshaft to the right. This way the teeth will slide together easier and the chamfered tooth and match mark will line up.

SECTION 2. BEARINGS

BEARING ASSEMBLY. The following figure illustrates the correct assembly of the tapered crankshaft bearings. The bearing at the flywheel end of the crankshaft seats in an adjustable bearing cup "A" in the cylinder.

The bearing cup "B" supporting the P.T.O. end of the crankshaft is a press fit in the cylinder cover.

Examine the bearing for wear, pitting, rust, alignment, and uneven wear of the rollers. If in doubt, replace to assure dependable trouble free service.

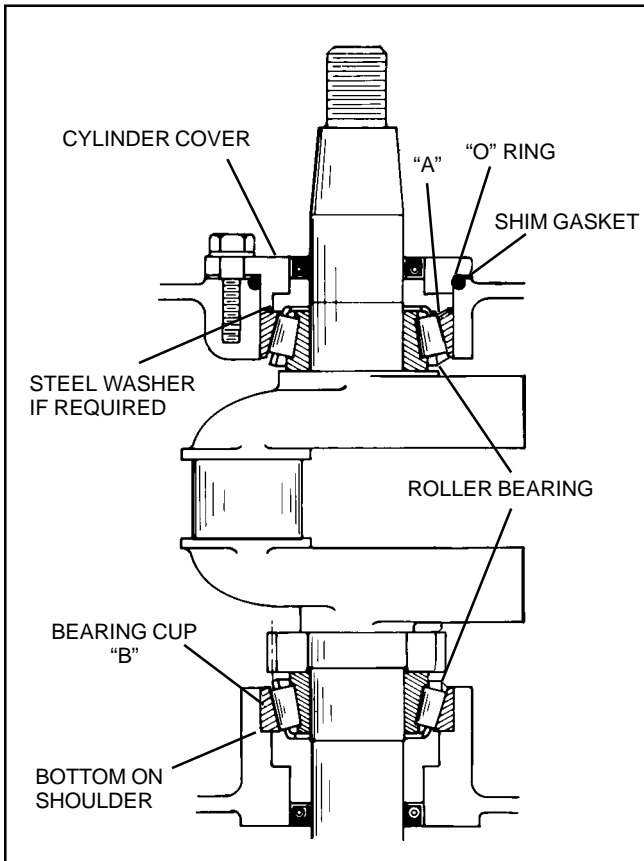

BEARING REMOVAL. Remove the bearing by securing a bearing separator between the bearing and crankshaft gear. Secure jaws of puller on the separator and draw bearing off shaft.

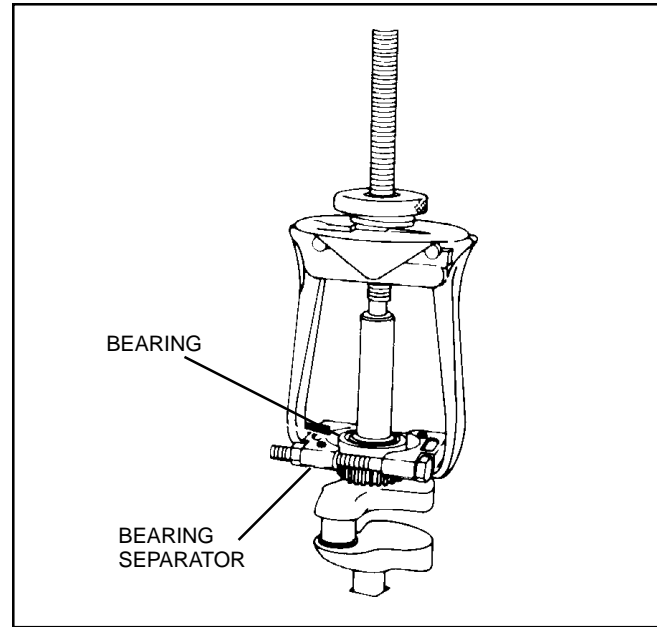

! THIS SYMBOL POINTS OUT IMPORTANT SAFETY INSTRUCTIONS WHICH IF NOT FOLLOWED COULD ENDANGER THE PERSONAL SAFETY AND/OR PROPERTY OF YOURSELF AND OTHERS. READ AND FOLLOW ALL INSTRUCTIONS.

BEARING INSTALLATION. Use only new bearings for installation on the crankshaft. Once a bearing has been removed it **MUST** be **REPLACED** as it becomes distorted and damaged while being removed. The new bearing may be installed on the crankshaft with pressure or heat. Heating the bearing is the preferred method.

METHOD ONE - Using Heat. Heat the bearings in engine oil. Support the bearing off the bottom of the container as illustrated.

! Heat to approximately 300° F (148° C) or until oil smokes. Support the crankshaft in a vise. Hold the bearing carefully to prevent burns. Work rapidly to assure proper placement while the bearing is hot. The bearing must seat tight against the shoulder of the magneto end and tight against the crankshaft gear on the P.T.O. end. (If on a counterweight system, bearing should be against counterweight gear.)

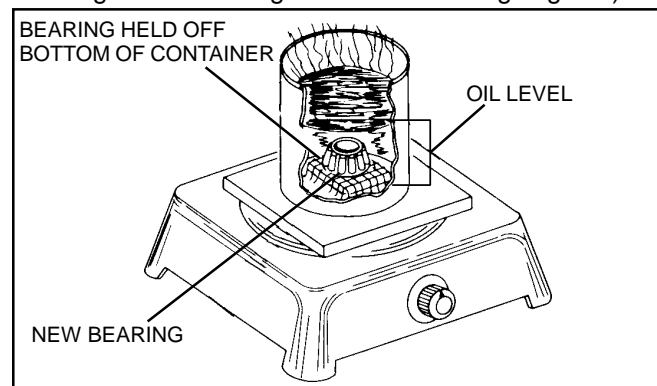

METHOD TWO - Cold Bearing. The crankshaft **MUST** be supported between the counterweights when pressing on bearings. Use a driver to direct the pressure of an arbor press onto the inner race of the bearing when installing. The bearing must be seated tight against the shoulder of the crankshaft counterweight (on magneto end).

⚠ This method may require a great amount of force, therefore, method one should be considered first.

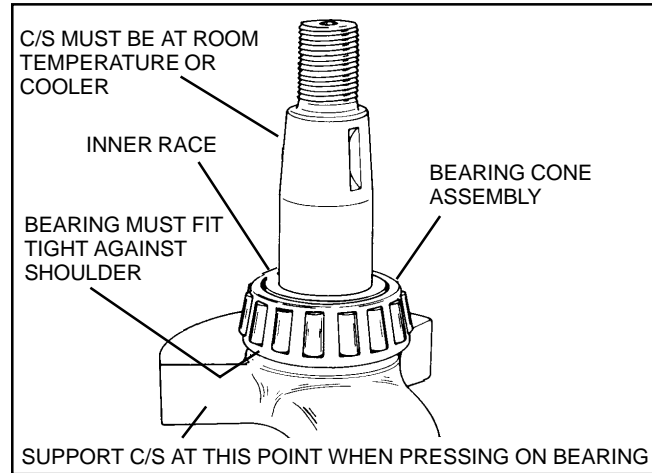

BEARING CUP INSPECTION. The bearing cup should be examined for rust, pitting, scuffing, cracks or other damage.

The bearing cup is removed by tapping the edge beneath the oil seal with a light hammer and flat punch. Press in a new cup until it bottoms on the shoulder. The bearing cup must be pressed in square, use an arbor press.

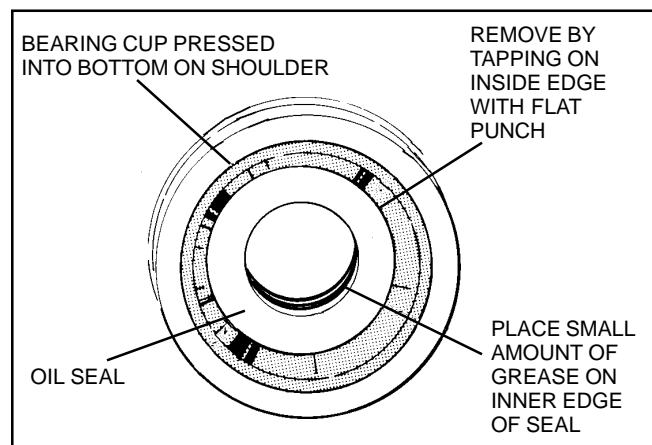

PROCEDURES FOR CYLINDER COVER FIT. Reinstall cylinder cover using a new gasket and torque to specifications.

After the cylinder cover is secured to correct torque specification, place the engine in a stand or device that will allow the P.T.O. (Power Take-Off) shaft to extend freely. Turn the crankshaft until the piston is at T.D.C. Tap the flywheel end of the crankshaft lightly with a mallet to seat the P.T.O. bearing. With either fingers or two screw drivers, press the bearing cup inward until tight.

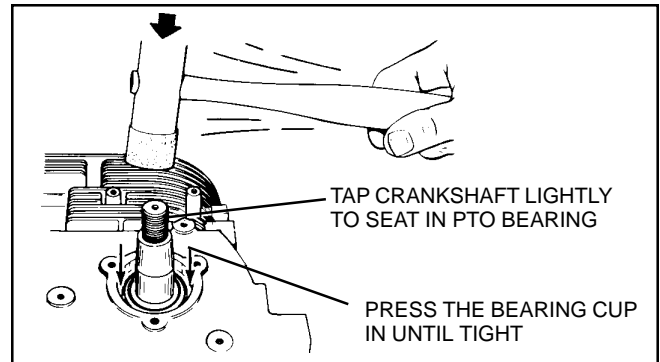

Position the cylinder cover (magneto end), oil seal, and sleeve tool over the crankshaft and seat on the machined gasket surface. Insert a feeler gauge between the cover and cylinder, record the reading.

If there is no space between the cover and the machined gasket surface to allow insertion of the feeler gauge, use a .010" (.254 mm) metal spacer. The spacer fits between the bearing cup and inside surface of the cover. More than one may be used if required.

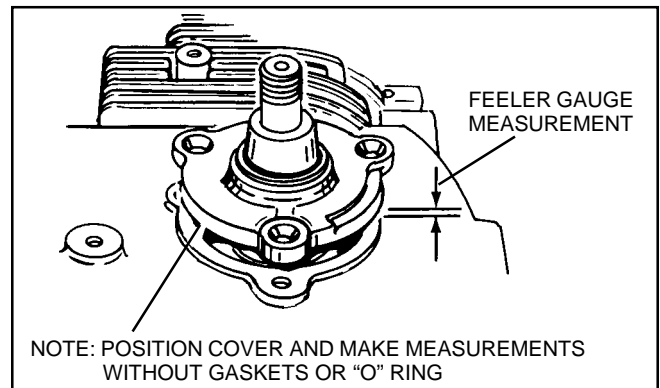

Determine the gap between the cover and the machined surface on the cylinder, which should be from .001" - .007" (.025 mm - .178 mm), in which case no shim gaskets will be required. However, if the space measures over .007" (.178 mm), follow the example below. Use of gaskets must be limited to a combined total of .010" (.254 mm) thick. Steel spacers must then be used to eliminate crankshaft end play. (Note: For VH100 with oil pump, see procedure on next page).

Example:

.010"	.254 mm	clearance measured between cover and cylinder. If clearance is over .010" (.254 mm), use spacer.
- .004"	-.102 mm	.001" to .007" (.025 - .1278 mm) allowed but use .004" (.102 mm) as the median.
= .006"	= .152 mm	Shim thickness required
+ .006"	.152 mm	Double above figure for thickness required to compensate for gasket compression
.012"	.305 mm	total amount of shim gaskets required

(Continued on top next page)

When the space measures .001" (.025 mm) to .007" (.178 mm) no gaskets required, or if over .007" and shimmed with gaskets the end result is that there shall be no crankshaft end play. Shim gaskets are available in .004/.005" (.102/.127 mm) and .005/.007" (.127/.178 mm) thickness.

NOTE: If clearance between cover and cylinder is over .007" (.178 mm) and gasket shims are not used, damage to the cylinder cover can result.

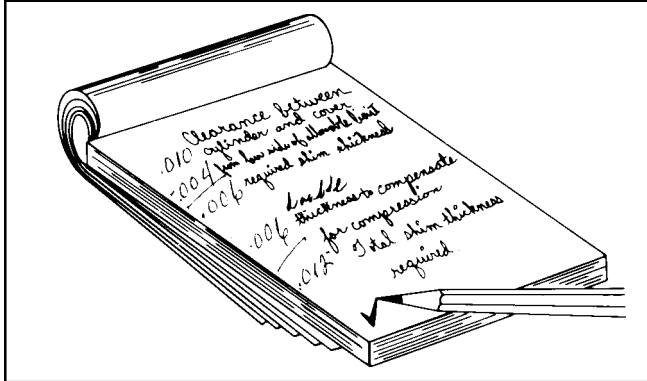

Insert an oil seal in the cover. Position the .010 (.254 mm) spacer, if required. Position the shim gaskets (if required) and place the cover on the cylinder. Use an oil seal sleeve to protect the oil seal. Secure the cover with the hex head bolts and TORQUE. See Specifications. Rotate the crankshaft and test for freedom of movement. There shall not be any crankshaft end play. The only exception is the VH100 with oil pump.

Knocking noise in an engine may at times be traced to excessive radial crankshaft play. If this is noted, review the cover shim gaskets. Correct by adding or removing as required.

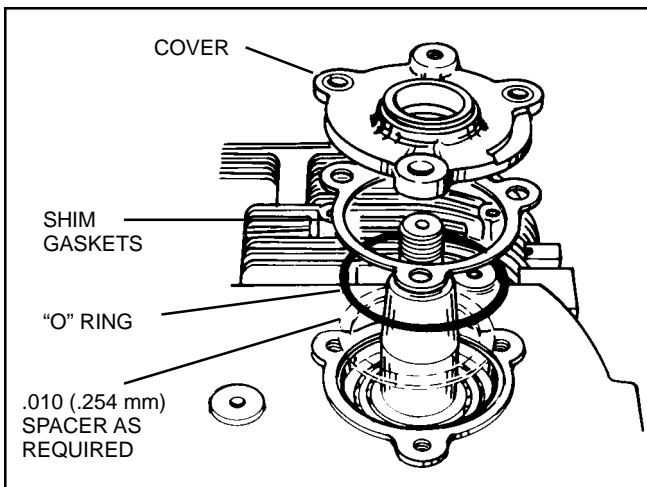

Newer model engines have an "O" ring which seals between the shim gaskets and the chamfer on the crankcase.

END PLAY ADJUSTING PROCEDURES FOR VH100 WITH OIL PUMP

After the cylinder cover is secured to correct torque specification, place the engine in a stand or device that will allow the P.T.O. (Power-Take-Off) shaft to extend freely. DO NOT set engine on P.T.O. shaft or the correct crankshaft end play cannot be obtained. Turn the crankshaft until the piston is a T.D.C. Tap the flywheel end of the crankshaft lightly with a mallet to seat the P.T.O. bearing.

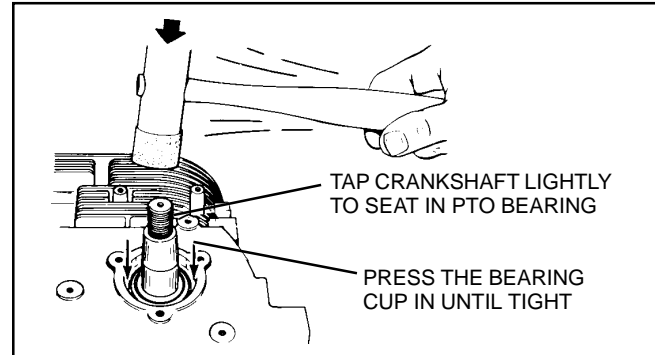

With either fingers or two screwdrivers, press the bearing cup inward until tight.

NOTE: When measuring for crankshaft end play be sure shim gaskets and O rings are removed.

Position the cylinder cover (magneto end), oil seal, and sleeve tool over the crankshaft and seat on the machined gasket surface. Insert a feeler gauge between the cover and cylinder; record the reading.

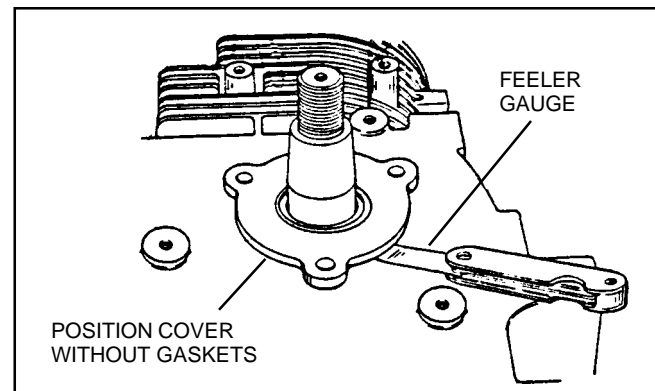

If space does not exist between the cover and the machined gasket surface to allow insertion of the feeler gauge use a .010 (.254 mm) metal spacer. The spacer fits between the bearing cup and inside surface of the cover. More than one may be used if required.

After determining the gap between the cover and the machined surface on the cylinder, determine the shim thickness as follows to result in the required .002 - .007 (.051 - .178 mm) crankshaft end play.

Example:

.003"	.076 mm	Clearance between cover and cylinder
- .002"	.051 mm	Required end play
<hr/>		
.005"	.127 mm	Shim thickness required
+ .003"	.076 mm	Add half above figure for thickness required to compensate for gasket compression
<hr/>		
.008"	.203 mm	Use shim gaskets that total this amount.

Shim gaskets are available in .004/.005" (.102/.127 mm) and .005/.007" (.127/.178 mm) thickness.

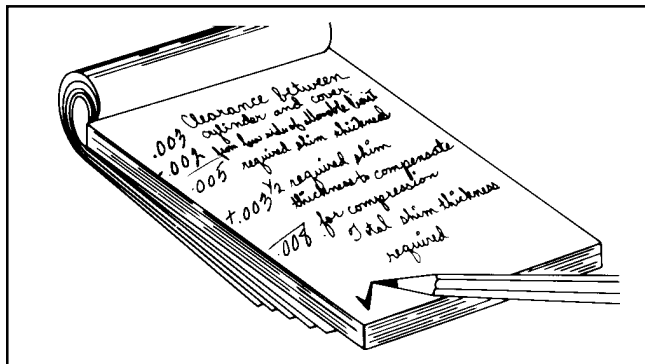

Insert an oil seal in the cover. Position the .010 (.254 mm) spacer if required. Position the shim gaskets and O ring and place the cover on the cylinder. Use an oil seal sleeve to protect the oil seal. Secure the cover with the hex head bolts and TORQUE to specifications. Rotate the crankshaft and test for freedom of movement, end play and radial play.

Knocking noise in an engine may at times be traced to excessive radial crankshaft play. If this is noted, check the cover shim gaskets. Correct by adding or removing as required.

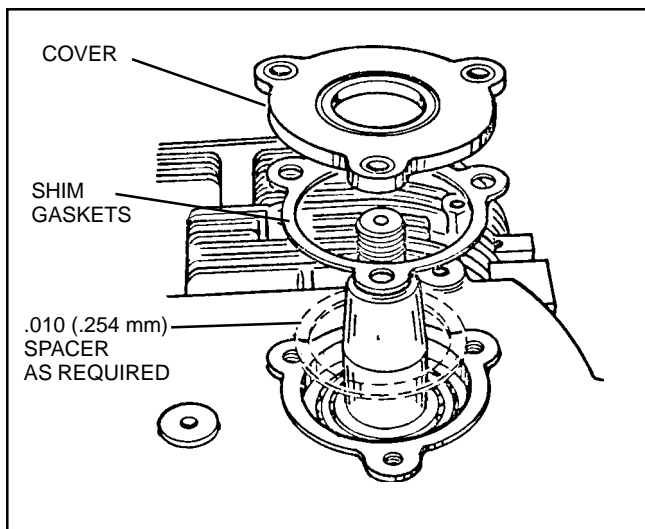

The bearing cup should be examined for rust, pitting, scuffing, cracks or other damage.

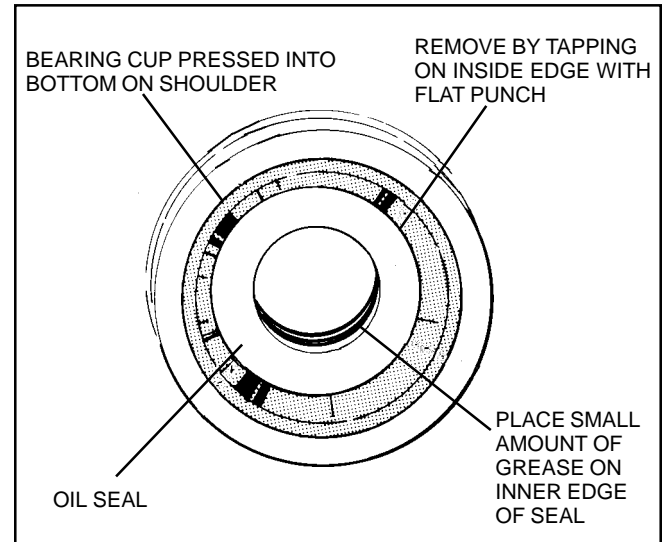

The bearing cup is removed by tapping the edge beneath the oil seal with a light hammer and flat punch. Press in a new cup until it bottoms on the shoulder. The bearing cup must be pressed in square, use an arbor press.

Reinstall cylinder cover using a new gasket and torque to specifications.

SECTION 3. SEALS

Use an oil seal protector when removing covers from crankshaft. See Chapter 11 of Mechanics Manual under "Tools", using tool as shown. Remove the cylinder cover at either the P.T.O. or flywheel end. Drive the seal out of the cylinder cover from the inside out. Install a new seal. Use new gaskets. Use the seal protector when replacing the cover.

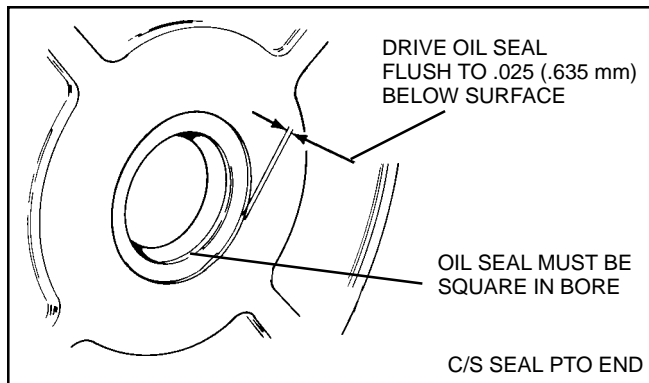
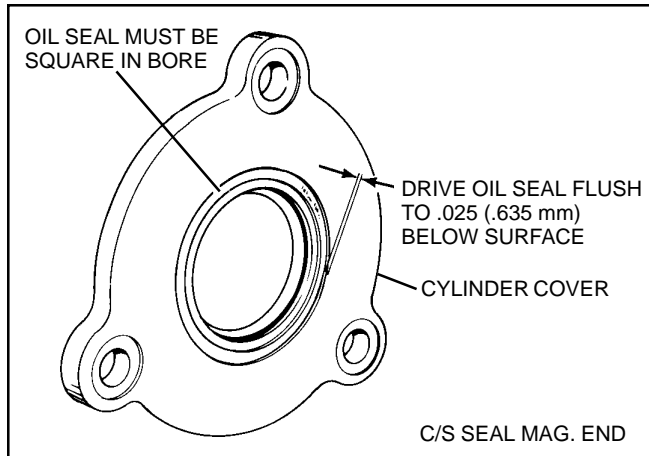

Remove the covers before installing the oil seal. The crankshaft cannot protrude while the seal is being installed.

Lay the cover on a flat clean surface. Use a seal driver and the correct seal installer to drive the seal into position. (See Chapter 11, Technician's Manual for tools). Place the seal onto the seal protector/installer and then over the bore, center the driver over the seal and drive the seal into position with a hammer.

USE A SEAL PROTECTOR EVERY TIME THE OIL SEAL IS PUT ONTO OR PULLED OFF OF THE CRANKSHAFT.

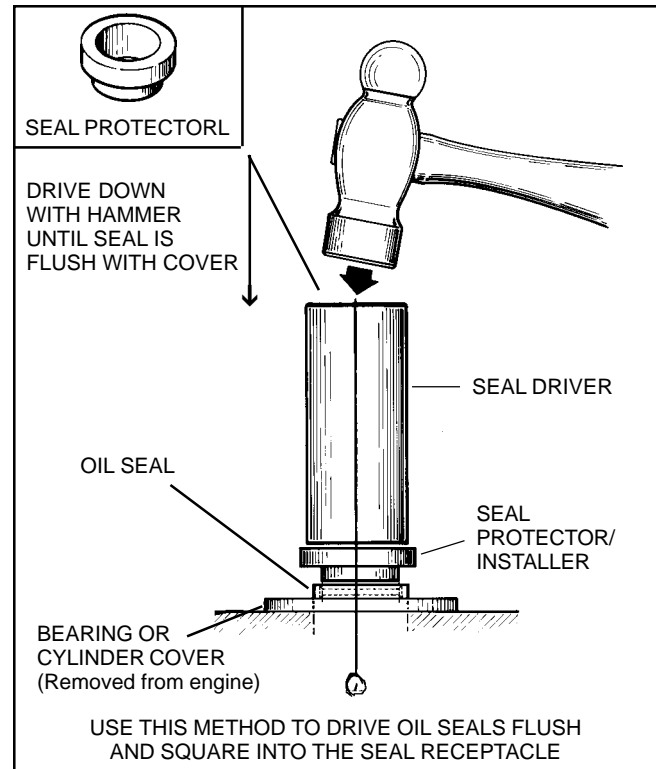

CHAPTER 7. DYNA-STATIC® BALANCING SYSTEM

TECUMSEH DYNA-STATIC® BALANCING SYSTEM.

Dyna-Static® Tecumseh's Balancing system for horizontal crankshaft 10, 12, 14, 16 and 18 H.P.

Dyna-Static® operates by means of a pair of counterweighted gears driven off the crankshaft to counteract the unbalance caused by the counterweights on the crankshaft. The exterior distinguishing feature of an engine equipped with a balance system is the "deep-dished" side cover. This cover contains the counterbalance gears and shaft.

Tecumseh Dyna-Static® balancing system also utilizes a helical (angle) cut set of gears consisting of a crankshaft gear and two counterbalance gears. There are two sets of helical counterweight assemblies. The difference between the two assemblies is the counterweight mass. They cannot be distinguished by size. Check Parts Manual or Microfiche for correct counterweight set. The helical cut gear assemblies may be interchanged with the regular cut gear assemblies, but only if all three gears (crankshaft gear and two counterweight gears) are interchanged as a set.

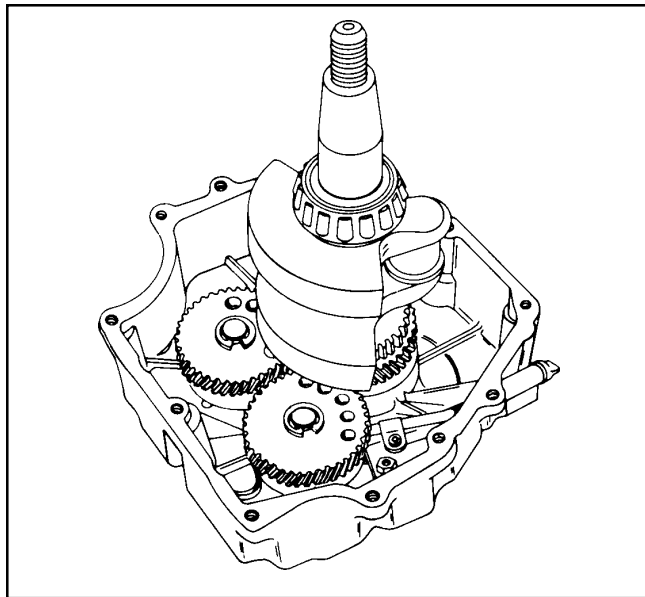

On some production models the counterbalancing gears are placed top and bottom of crankshaft.

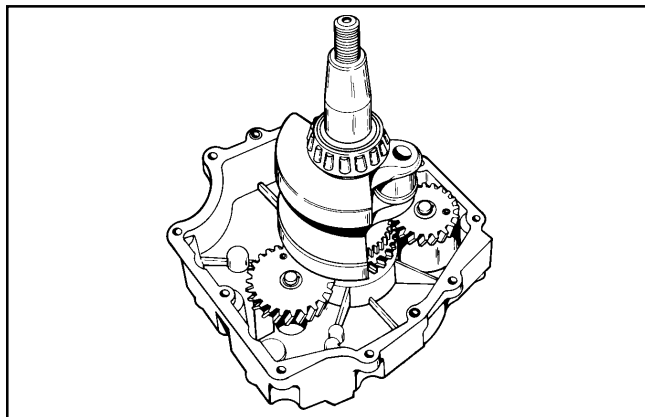

ALIGNING THE COUNTERWEIGHTS (Side-by-Side counterweights) This view of the side cover is from the outside showing the pipe plugs which plug the alignment holes during normal operation.

NOTE: Be careful when installing the cylinder cover that the counterweight balance gears remain in alignment.

Remove pipe plugs from flange, assemble flange to cylinder making sure the slots stay in hole. Slots may have to be moved either way with punch or screwdriver to mesh gears. If you can see any part of slots in holes after assembled, it is correctly assembled. Reinstall pipe plugs.

The important thing is to keep the counterweight gears perfectly aligned on the crankshaft gear. Any misalignment of these gears can cause vibration. Insure also that the governor rod assembly is correctly placed.

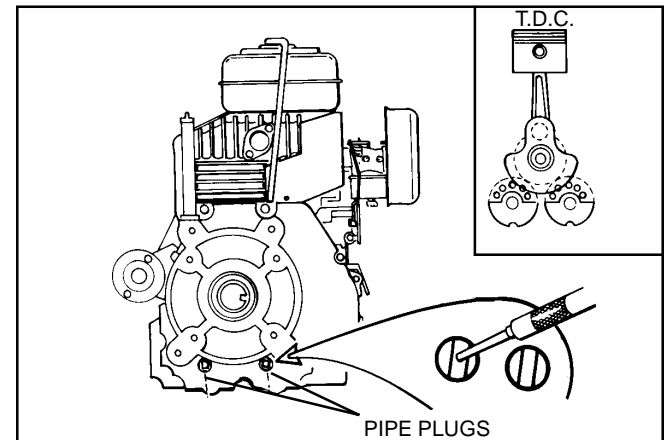

TOP & BOTTOM COUNTERWEIGHTS

On some production models the counterweight balancing gears are placed top and bottom of the crankshaft. The gears mesh with the driver gear on crankshaft when the piston is at T.D.C. and the gear weights are down as shown.

NOTE: If a damaged gear is replaced, the mating gear should also be replaced.

Example: If the camshaft is damaged and replaced, the crankshaft gear should be replaced.

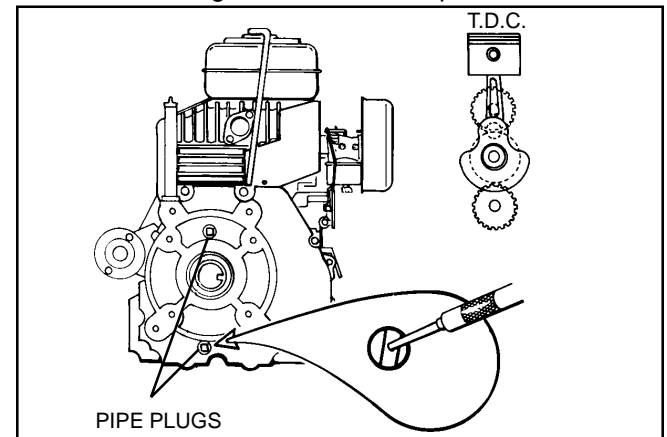

Positioning of helical-type gears is the same as shown in the figure below.

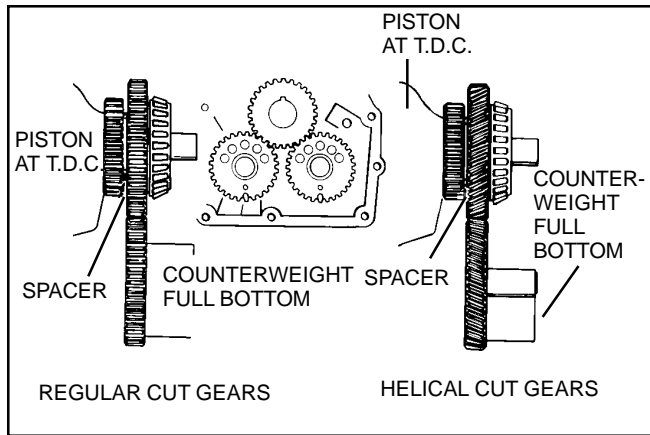

CRANKSHAFT GEAR ALIGNMENT

NOTE: Whenever the camshaft gear is damaged, the crankshaft gear should be replaced.

Note the chamfer tooth on the crankshaft gear. This tooth is used as a reference mark to be matched with the timing mark on the camshaft.

On engines equipped with Dyna-Static, the counterbalance weight drive gear is installed between the crankshaft gear and the bearing with a spacer.

The crankshaft gear and the counterbalance weight drive gear are replaceable. Remove gears with a conventional puller after the roller bearing has been removed.

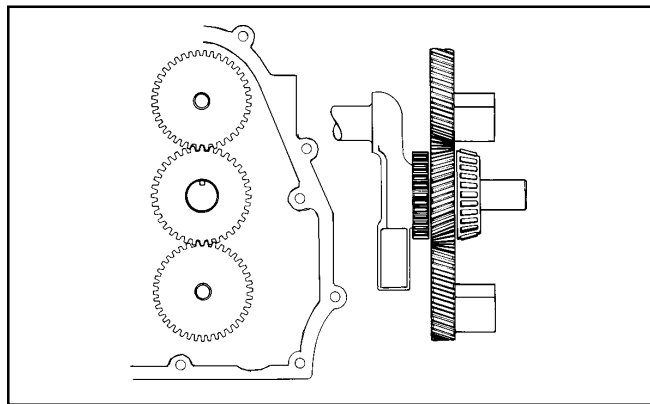

The figure below shows one counterbalanced driven gear removed from the shaft. Each counterbalanced shaft is pressed into the cylinder cover so that a dimension of 1.7135" (43.523 mm) to 1.7185" (43.650 mm) exists between the side cover boss and the end of the shaft.

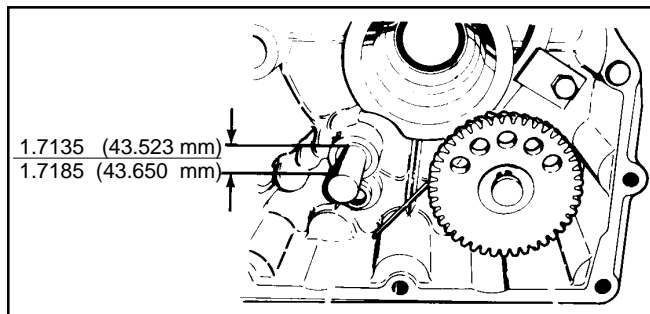

On current production models, the counterweight balancing gears are placed top and bottom of the crankshaft. The position dimension is the same as for side-by-side counterweight models.

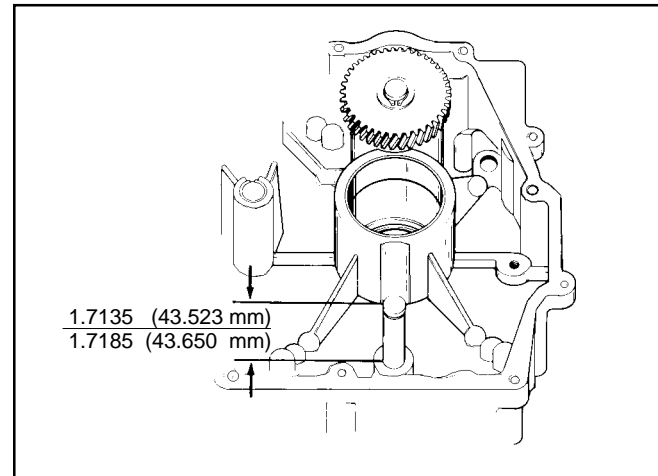

BEARING REPLACEMENT.

If replacement of caged needle bearings is required, press the replacement in flush to .015 (.381 mm) below inside surface, use tool No. 670210. This figure shows the counterweight side and the slot cut for the tool alignment.

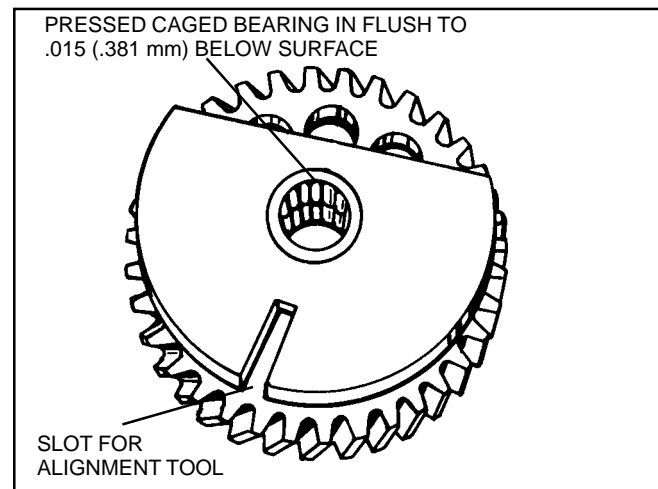

CHAPTER 8. IGNITION SYSTEMS, CHARGING SYSTEMS BATTERY SERVICE and ELECTRICAL CONTROL PANELS

SECTION 1. IGNITION SYSTEMS

SOLID STATE SYSTEM IGNITION SERVICE.

a. General. Follow through the checks and explanations below, if everything checks ok, then replace the ignition unit. The parts of the system are:

1. Ignition coil.
2. Flywheel.
3. Ignition unit.
4. High tension lead.
5. Spark plug.

b. Spark Plug Check. Test ignition by using a test plug or hold the high tension lead terminal 1/8-in.(3.175 mm) from the spark plug. Crank the engine over rapidly. If a good blue spark jumps the gap, the ignition system is functional.

If no spark is present, make the following checks: c through f.

- c. Check high tension lead for a ground or an open circuit in the ignition unit.
- d. Check coil lead and connection to ignition unit terminal.

CAUTION: If the engine won't run, after previous acceptable performance, check the equipment ignition switch.

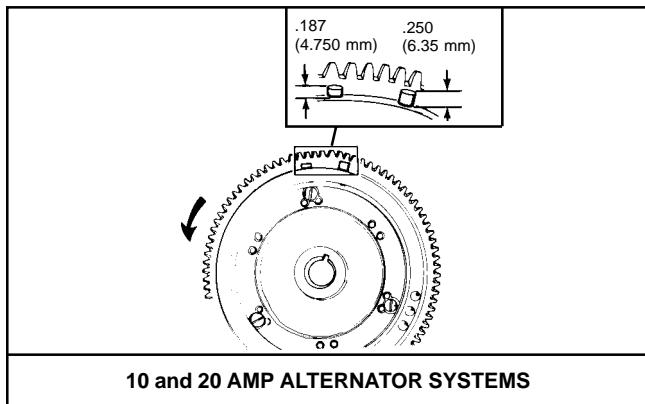
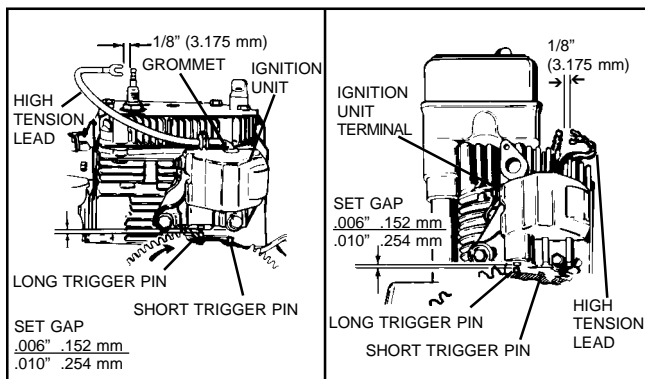

e. Air Gap Checks. Adjust the system so that a .006/.010" (.152/.254 mm) clearance exists between the ignition unit and the long trigger pin in the flywheel.

To adjust, loosen the retaining screw and move the unit to find the proper gap.

Follow through the checks and explanations below, if everything checks ok, then replace the ignition unit.

REMOVAL OF FLYWHEEL TRIGGER PINS

Removal of damaged pins. CAUTION: Pins must not be reused. Use care not to damage flywheel. Never hammer on a flywheel as permanent damage to the magnets could result.

Use vise-grip pliers to remove the pins. If the pins are very tight, hammer lightly on the pliers at the same time pulling on the pins. Do not twist. If a vise is used to secure the flywheel, use care not to damage.

INSTALLATION OF NEW TRIGGER PINS.

1. Position the flywheel with the fins on a flat surface. Holes toward you - See Figure.
2. Coat shaft of pins with Loctite.
- CAUTION:** Do not use a hammer to drive in pins.
3. Use masking tape to cover wide-mouth pliers (channel lock type) and press fit the short pin into hole on right. Fit the long pin on the left.
4. Pins must be pressed up to pin shoulder. Wipe away any excess Loctite.
5. The magneto air gap must now be adjusted to correct for any changes in trigger pin height.

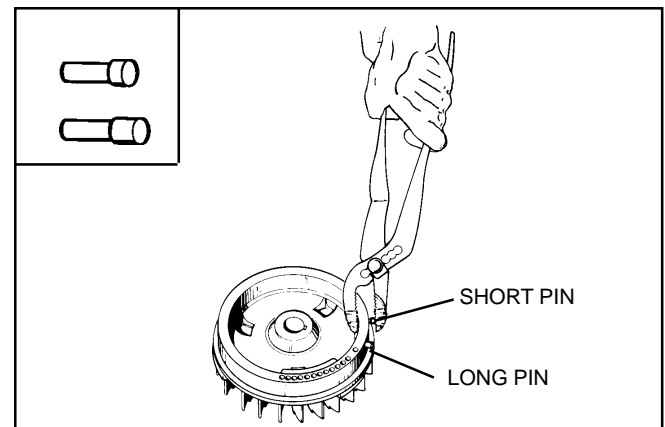

f. Coil Lead on 10 Amp Alternator Systems. Remove the coil lead from the ignition unit terminal. Attach the leads from a standard ohmmeter to the lead eyelet and to ground to check series resistance of the ignition generator coil.

1. If resistance is below 400 ohms, replace the stator assembly which includes the coil.

NOTE: The ignition generator coil cannot be replaced separately.

2. If coil resistance is above 400 ohms, replace the ignition unit.

CAUTION: Before replacing Ignition Unit, meter ignition cutoff circuit in the switch for a "short", allowing battery current to burn out the ignition unit.

Remove the switch and connect the leads from a continuity meter to the battery lead terminal and the ignition ground terminal. Actuate the switch in various positions to see if continuity exists. Any continuity indicates a bad switch. When replacing a switch be sure that the lead and terminal do not short through the equipment frame.

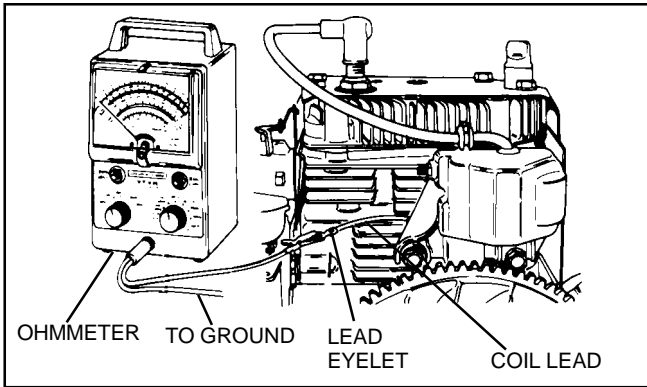

CONNECTIONS ARE THE SAME FOR 8 H.P. AND LARGER AND VALVE-IN-HEAD ENGINES

g. Coil Lead on 20 Amp Alternator Systems. Remove the coil lead from the ignition unit terminal. Attach leads from a standard ohmmeter to the lead eyelet terminal and to ground to check series resistance of the ignition generator coil.

If coil resistance is between 115 ohms and 171 ohms, replace the ignition unit.

CAUTION: Before replacing Ignition Unit check the ignition cutoff circuit in the switch, for a "short" allowing battery current to burn out the ignition unit. Remove the switch and connect leads from a continuity meter to the battery lead terminal and the ignition ground terminal. Actuate the switch in various positions to see if continuity exists as shown on the meter. Any continuity indicates a bad switch. When replacing the switch be sure that the lead and terminal do not short through the equipment frame.

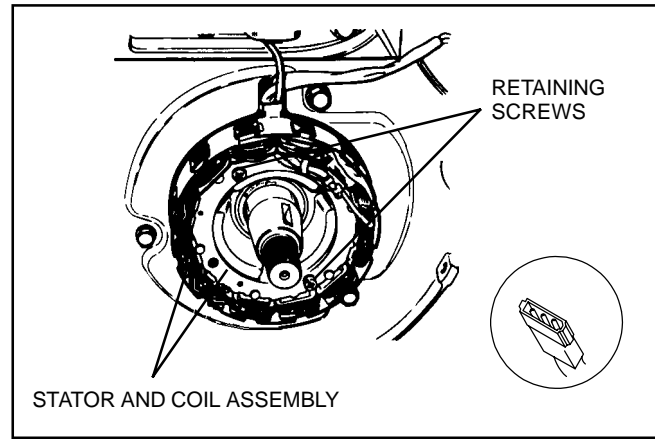

FOR 10 AMP IGNITION SYSTEM

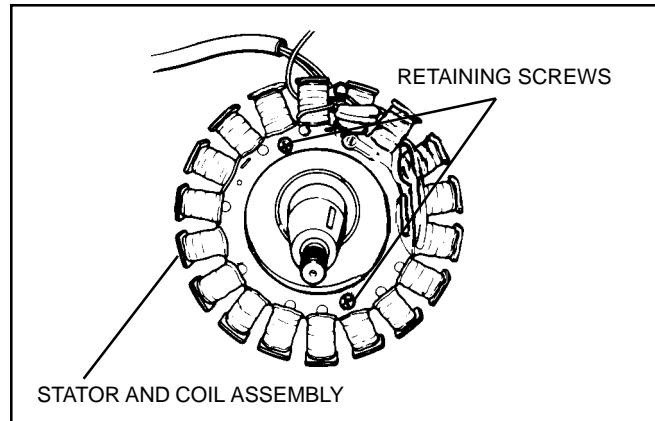

FOR 20 AMP IGNITION SYSTEMS

SOLID STATE IGNITION SYSTEM (NON-ALTERNATOR TYPE).

CAUTION: Do not attempt to crank engine with the primary wire of the transformer disconnected. Also do not allow the primary wire of the transformer to be grounded or arc. A broken wire causing an open circuit to or in the transformer can also cause permanent damage. See Step 2.

1. Preliminary Tests

Spark Test . . . Check for spark.

Perform the following visual tests:

HIGH TENSION LEAD . . .Inspect for cracks or indications of arcing. Replace the transformer if a questionable lead is found.

LOW TENSION LEADS . . .Check all leads for shorts. Check ignition cut-off lead to see that unit is not grounded out. Repair leads if possible, or replace.

FLYWHEEL . . .Check magnets for strength. Check key and keyway. Be sure that the key locks the flywheel to the crankshaft.

2. After the above visual checks are made the transformer and solid state components can be checked using a Merc-O-Tronic, Graham-Lee or similar tester.

NOTE: Before using parts for tests, be sure any problem which caused replacement is corrected first.

3. When testers are not available... Use new replacement parts as test for possible failed parts.

SOLID STATE STATOR - Replace and test for spark. Time the magneto by turning counterclockwise as far as it will go. Tighten retaining screws to 5-7 foot pounds (6.8 - 12.4 mm).

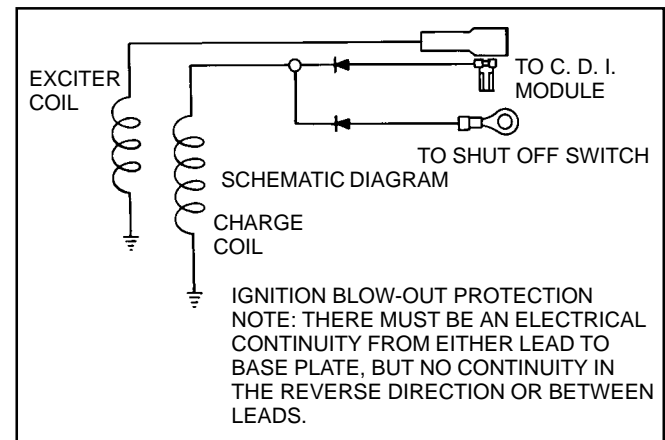
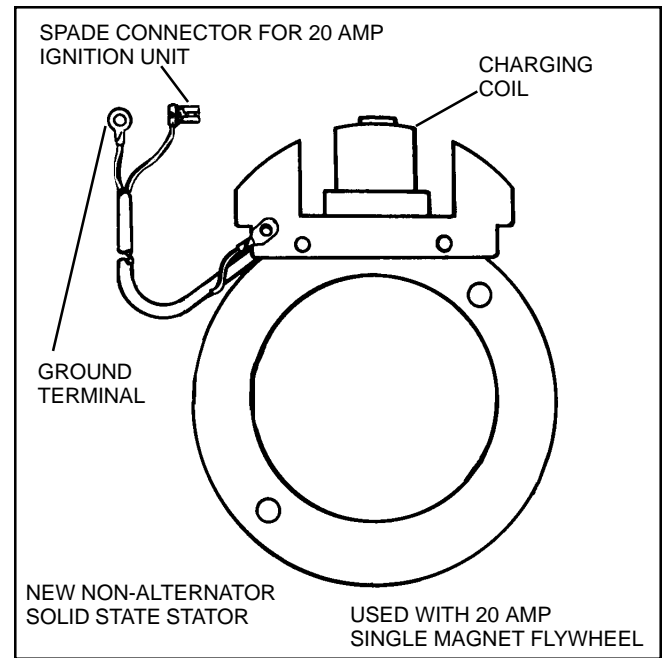

STATOR PLATE ASSEMBLY (20 AMP SYSTEM). Previous tests also apply, except for the following:

1. Test the ignition unit first. If good, remove flywheel and check coil for continuity.
2. Determine if correct flywheel is used, if previously replaced. The flywheel used for a 20 amp system is not compatible with flywheel used on a 10 amp systems.
3. The stator cannot be turned once secured with stator bolts.

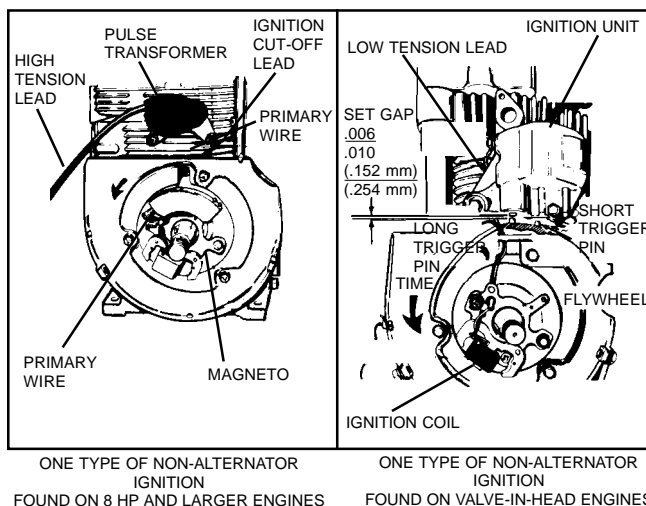

SECTION 2. CHARGING SYSTEMS

PRECAUTIONS

CAUTION: Electrical components of the 10 amp alternator system are similar to the 20 amp alternator system. Use care not to interchange electrical components; severe damage will result.

- A. Do not connect battery to cables in wrong polarity. This will cause regulator-rectifier damage.
- B. Break continuity between the regulator-rectifier unit and battery when using a remote charger on the battery. This will eliminate damage to the regulator-rectifier if polarity is reversed.
- C. Disconnect wiring harness at regulator-rectifier before using arc welder on equipment.
- D. Do not short alternator leads together.
- E. When normally running the engine DO NOT disconnect the lead to the battery.

NOTE: Only when testing the D.C. output, should the D.C. output lead be disconnected from the battery.

- F. If wiring must be replaced in any part of the circuitry, be certain the same size (gauge) wire is used. Wire between the battery to the starter motor must be a minimum of No. 6 gauge. For the 20 amp alternator system the charge circuit uses No. 14 gauge wire. Most of the remaining portion of the circuitry will be No. 18.

Newer 20 amp systems are distinguished by the regulator-rectifier installed in the blower housing. Connectors are not interchangeable with connectors on the external type regulator-rectifier 20 amp system.

Do not force or modify connectors. Test values are identical to original 20 amp alternator system.

PRE-SERVICE CHECKS

- a. Check for a good ground between regulator-rectifier and mounting.
- b. Check for poor connections or broken wires.
- c. Check the fuse.

NOTE: Battery voltage must be above 6 volts for the regulator to be activated. This applies only to the 20 amp system with regulator-rectifier in housing.

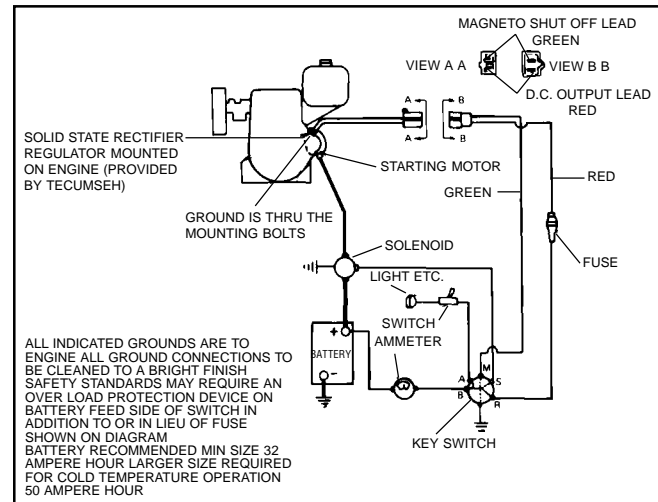

20 AMP. ALTERNATOR SYSTEM

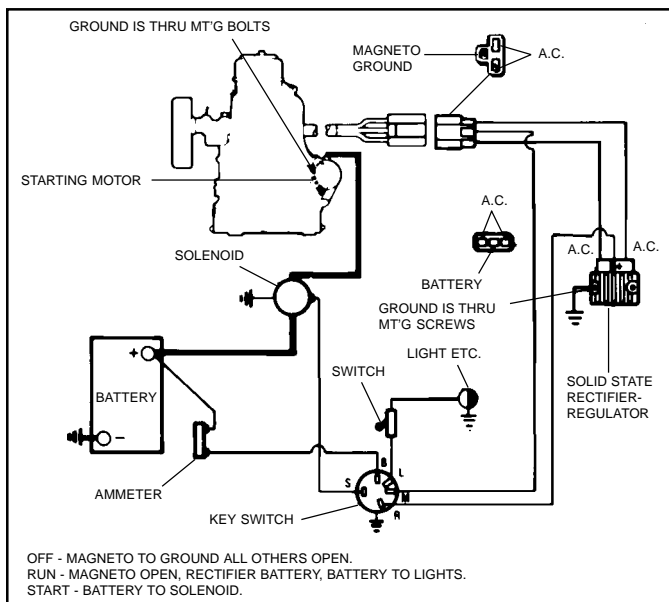

10 AMP. ALTERNATOR SYSTEM

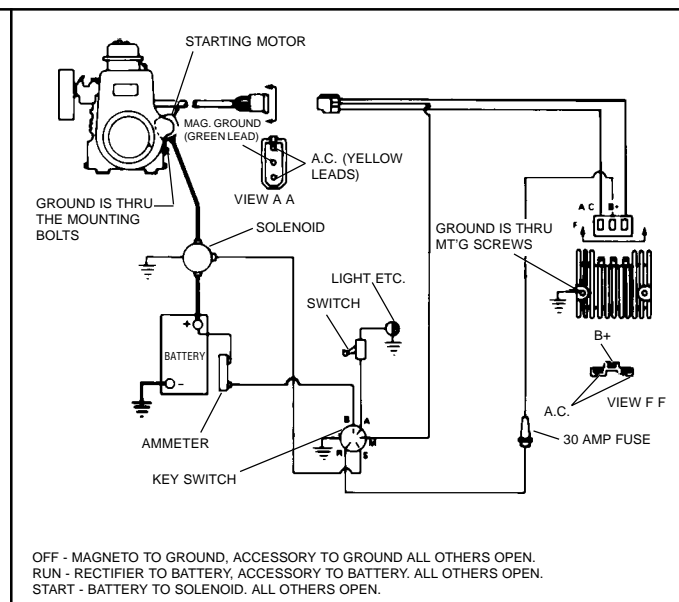

20 AMP. ALTERNATOR SYSTEM

Before performing the following tests see page 48, A through F.

TEST NO. 1 (NO CHARGE TO BATTERY)

NOTE: Tests must be followed in their order of listing. EXAMPLE: Test No. 1 must be completed before proceeding to Test No. 2. Replace any defective part.

10 AMP ALTERNATOR TEST

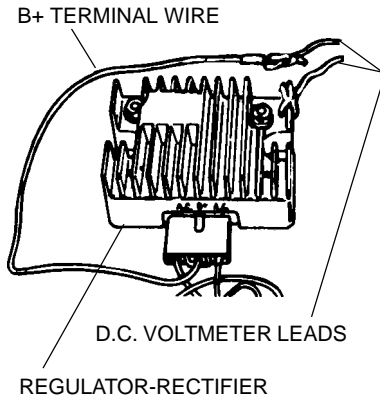

Disconnect B+ at battery lead (NOTE: Keep test to a minimum with B+ wire disconnected from the battery) and check D.C. voltage between B+ regulator lead and case:

- | | |
|--|---|
| <ol style="list-style-type: none"> 1. 2500 RPM 13.0 volts min.
3000 RPM 16.0 volts min.
3600 RPM 20.00 volts min. 2. If less than above voltages but greater than 0 volts. 3. If 0 volts at any above speeds. | <ol style="list-style-type: none"> 1. System okay. Check for defective ammeter. 2. Check for possible defective regulator-rectifier. 3. Check for defective stator or regulator-rectifier. |
|--|---|

TEST NO. 2 (NO CHARGE TO BATTERY)

With battery connected, check B+ to ground voltage with D.C. voltmeter.

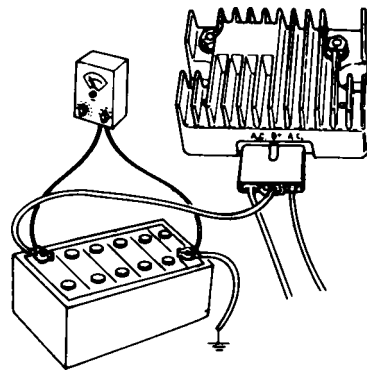

- | | |
|---|--|
| <ol style="list-style-type: none"> 1. 2500 RPM: If 11.0 volts or higher place load (head lights) on battery to reduce battery voltage to 10.0 volts. 3000 RPM: If 20.0 volts or higher place load (head lights) on battery to reduce battery voltage to 11.0 volts. 3600 RPM: If 13.5 volts or higher place load (head lights) on battery to reduce battery voltage to 12.0 volts. a. If charge rate increases. b. If charge rate does not increase. | <p>System okay. Battery was charged fully.</p> <p>Check for defective stator or regulator.</p> |
|---|--|

A.C. VOLTMETER LEADS

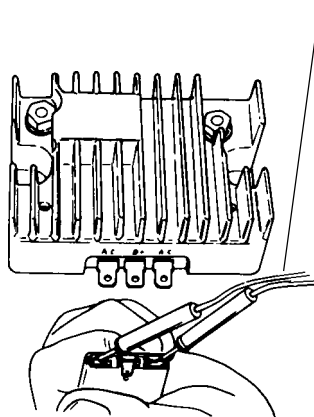

TEST NO. 3 (NO CHARGE TO BATTERY)

Disconnect plug from regulator-rectifier and test A.C. voltage at plug.

- | | |
|---|--|
| <ol style="list-style-type: none"> 1. 2500 RPM: Voltage reads less than 16 volts. 2. Voltage reads over 16 volts. 3. 3000 RPM: Voltage reads less than 19 volts. 4. Voltage reads over 19 volts. 5. 3600 RPM: Voltage reads less than 24 volts. 6. Voltage reads over 24 volts. | <ol style="list-style-type: none"> 1. Defective stator 2. Defective regulator-rectifier. 3. Defective stator 4. Defective regulator-rectifier. 5. Defective stator 6. Defective regulator-rectifier. |
|---|--|

TEST NO. 4 (BATTERY ALWAYS CHARGING AT HIGH RATE)

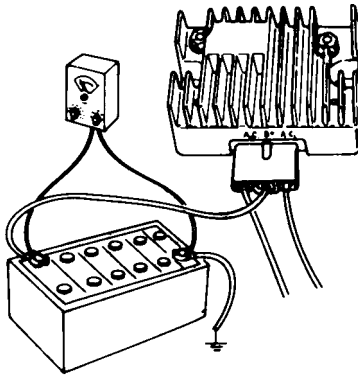

Check B+ to ground voltage with D.C. voltmeter.

- | | |
|--|---|
| 1. 2500 RPM: Voltage over 14.7 volts. | 1. Regulator not functioning. |
| 2. 3000 RPM: Voltage over 14.7 volts. | 2. Regulator not functioning. |
| 3. 3600 RPM: Voltage over 14.7 volts. | 3. Regulator not functioning. |
| 4. 2500 RPM: Voltage under 12.0 volts. | 4. Battery charge low. Alternator and Regulator System okay. Check battery. |
| 5. 3000 RPM: Voltage under 13 volts. | 5. Battery charge low. Alternator and Regulator System okay. Check battery. |
| 6. 3600 RPM: Voltage under 14.7 volts. | 6. Battery charge low. Alternator and Regulator System okay. Check battery. |

TEST NO. 5 (BATTERY BOILING OR FUMING)

Check B+ to ground voltage with D.C. voltmeter.

- | | |
|-------------------------------|---|
| 1. If over 14.7 volts. | 1. Regulator not functioning. |
| Visual check for overfilling. | Overfilled battery may appear to fume due to expansion. |

20 AMP. ALTERNATOR TESTS

Before performing the following tests, see page 48, A through F.

TEST NO. 1 (NO CHARGE TO BATTERY)

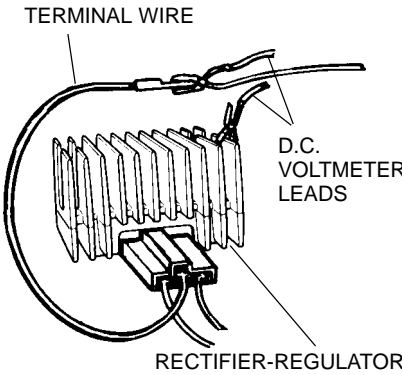

TEST SET-UP ON 20 AMP SYSTEMS WITH EXTERNAL REGULATOR-RECTIFIER

NOTE: Tests must be followed in their order of listing. EXAMPLE: Test No. 1 must be completed before proceeding to Test No. 2. Replace any defective part.

With battery connected check B+ to ground voltage with D.C. voltmeter.

- | | |
|--|---|
| 1. Place load (head lights) on battery to reduce battery voltage to below 12.5 volts. (This may take a few minutes.) | |
| 2. Start engine. Run at 2500 RPM, 3000 RPM and 3600 RPM with same load as above. | |
| a. If voltage increases. | a. System okay - Battery was charged fully. |
| b. If voltage does not increase. | b. Check for defective stator or regulator system. Tests No. 2 and No. 3. |

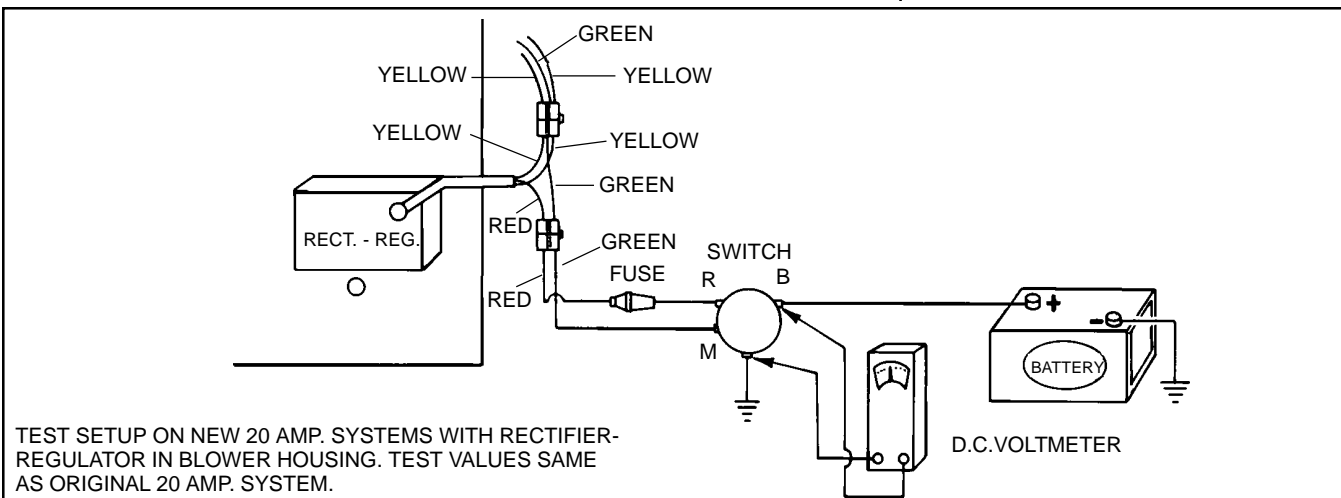

TEST SETUP ON NEW 20 AMP. SYSTEMS WITH RECTIFIER-REGULATOR IN BLOWER HOUSING. TEST VALUES SAME AS ORIGINAL 20 AMP. SYSTEM.

TEST NO. 2 (NO CHARGE TO BATTERY)

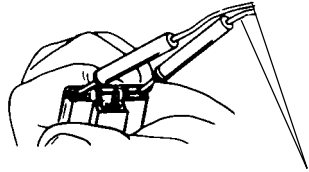
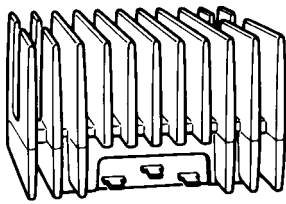

A.C. VOLTMETER LEADS

Disconnect plug from regulator and test AC voltage at plug.

- | | |
|--|---------------------------------------|
| 1. 2500 RPM: Voltage reads less than 32 volts. | 1. Defective stator. |
| 2. Over 32 Volts. | 2. Defective regulator See Test No.3. |
| 3. 3000 RPM: Voltage reads less than 38 volts. | 3. Defective stator. |
| 4. Over 38 volts. | 4. Defective regulator See Test No.3. |
| 5. 3600 RPM: Voltage reads less than 45 volts. | 5. Defective stator. |
| 6. Over 45 volts | 6. Defective regulator See Test No.3. |

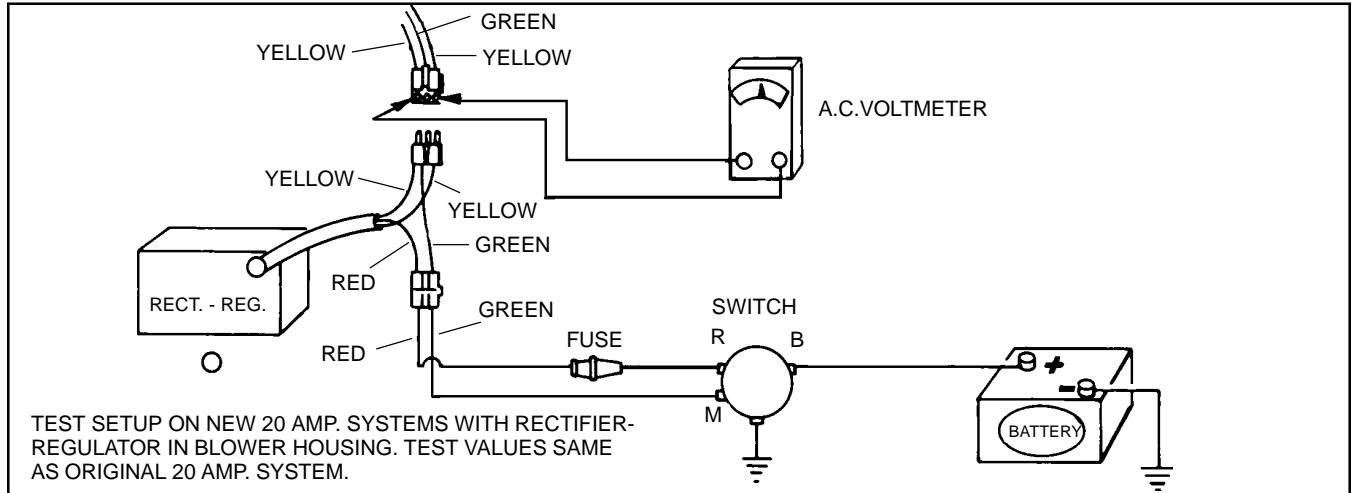

D.C. AMMETER

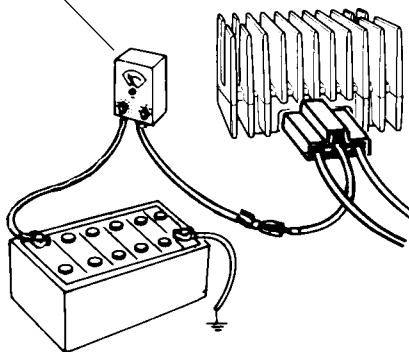

TEST NO. 3 (LOW CHARGE TO BATTERY)

Check current output with D.C. ammeter connected in series from B+ of regulator to positive side of battery.

- | | |
|--|----------------------|
| 1. 2500 RPM @ 12.5 volts load current reads less than 13 amps. | 1. Defective stator. |
| 2. 3000 RPM @ 12.5 volts load current reads less than 15 amps | 2. Defective stator. |
| 3. 3600 RPM @ 12.5 volts load current reads less than 17 amps. | 3. Defective stator. |

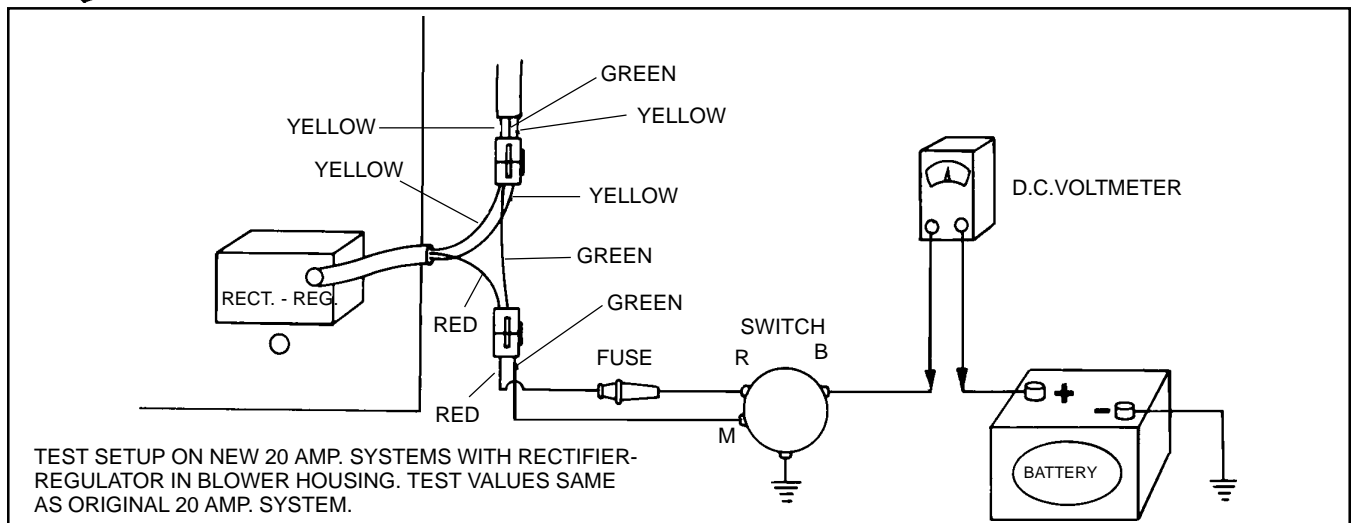

TEST NO. 4 (BATTERY ALWAYS CHARGING AT HIGH RATE)

Check B+ to ground voltage with D.C. voltmeter.

1. If over 14.8 volts at 2500 RPM, 3000 RPM, and 3600 RPM.
2. If under 14.4 volts @ 2500 RPM.
@ 3000 RPM.
@ 3600 RPM.

1. Regulator is not functioning.
2. Battery charge low. Alternator okay, check battery.

D.C. VOLTMETER

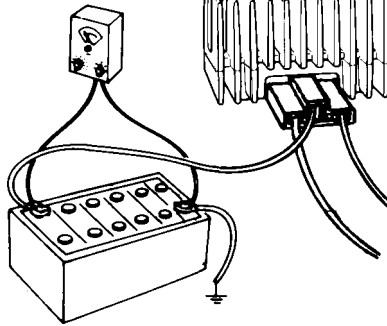

TEST NO. 5 (BATTERY BOILING OR FUMING).





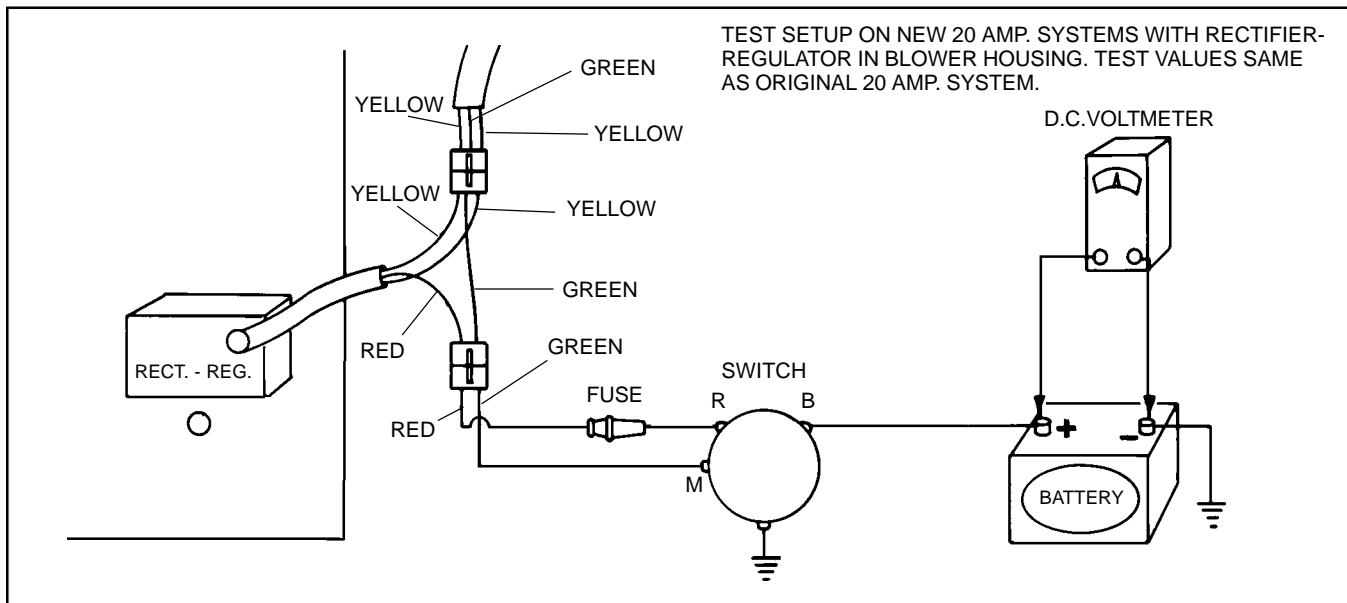

Check B+ to ground voltage with D.C. voltmeter.

1. If over 14.8 volts.
Visual check for overfilling.

1. Regulator not functioning.
Overfilled battery may appear to fume due to expansion.

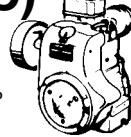

SECTION 3. BATTERY SERVICE

BATTERY POWER DECREASES WHILE ENGINE CRANKING POWER REQUIREMENT INCREASES WITH FALLING TEMPERATURE	
<p>100%</p> <p>80°F (26°C)</p>  <p>100%</p> 	<p>68%</p> <p>32°F (0°C)</p>  <p>165%</p> 
<p>46%</p> <p>0°F (-18°C)</p>  <p>250%</p> 	<p>30%</p> <p>-20°F (-30°C)</p>  <p>350%</p> 

BATTERY CHECK. Because the battery is part of two circuits starting, ignition and charging (in the ignition circuit, only in switch starting units) the battery should be checked first.

If battery has a shorted cell, overcharging can result, and the regulator rectifier may appear to be at fault. If a cell has an open or high resistance connection, cranking motor operation will be affected, but replacing the cranking motor will not cure the trouble. If the battery is badly sulphated, consistent low gravity readings, slow cranking, and possible poor ignition performance can be experienced during starting.

BATTERY SIZE RATIO: AMPERAGE TO TEMPERATURE. It is always good practice to select a replacement battery of an electrical size at least equal to the battery originally engineered for the vehicle by the manufacturer.

Battery power decreases while the need for engine cranking power increases with falling temperature. Subzero cold reduces battery capacity of a fully charged battery to 30% of its normal power and at the same time increases cranking load beyond the normal warm weather load.

Hot weather will place excessive electrical loads on batteries. Difficulty in starting may occur when cranking is attempted shortly after a hot engine has been turned off.

If the capacity rating for the original equipment battery cannot be determined, a 32 amp or greater rated replacement battery would be sufficient. **IMPORTANT:** For operation at colder temperatures, a 50 amp or

greater rating is recommended.

BATTERY CONDITION. While the battery is built to satisfactorily withstand the conditions under which it will normally operate, excessive mechanical abuse leads to early failure.

The following points are important to properly install a battery:

1. Be sure the battery carrier is clean and that the new battery rests level when installed.
2. Tighten the hold-down evenly until snug. Do not draw down tight enough to distort or crack the battery case.
3. Be sure the cables are in good condition and the terminal clamps are CLEAN. Grease battery terminals lightly with petroleum jelly before attaching cable clamps. Make sure the ground cable is CLEAN and TIGHT at the engine block or frame.
4. Check polarity to be sure battery is not reversed with respect to the generating system.
5. Connect "ground" terminal of the battery last, to avoid "short" circuits which will damage the battery.

CAUTION: The charging process will chemically liberate oxygen and hydrogen gasses. This highly flammable mixture may be dangerous if ignited. Disconnect ground terminal first to prevent arcing at the positive terminal.

BATTERY PRECAUTIONS. If a battery is not used for a long period of time, it is advisable to remove the terminal connections to prevent a slow discharge. On some units there is an ON-OFF switch to cut the battery out of the circuit when not in use.

Be careful when replacing battery connections. A reversal of polarity can cause damage to the regulator-rectifier.

BATTERY MAINTENANCE: (Acid-Type) Check water level periodically to determine that the top of the battery plates are covered. Never overfill !

Whenever possible, add only distilled water. If not available, use water with the lowest possible mineral content. Hard water will cause an accumulation of calcium deposits.

Never add water to a battery at below freezing temperatures unless the water has been thoroughly mixed with electrolyte first. This may be done by operating the engine for about 4 hours.

Do not add acid unless it has been lost. Only water in the sulfuric acid solution is normally evaporated through normal usage. If the solution has been lost by spilling, add acid so there is not more than a 10 to 1 ratio of acid to water.

Check to determine if the vent holes in the caps are open.

In normal usage the battery casing may be partially covered with a white powder. Clean such areas with a solution of 1 part bicarbonate of soda to 4 parts water. Use care to prevent solution from entering battery cells.

If battery terminals show corrosion, remove battery connections carefully. Do not twist or use unnecessary force to remove from battery. Brighten battery posts and connections. Coat battery posts and terminal connections with petroleum jelly and replace. (Never hammer on battery posts!)

TESTING THE BATTERY. Voltage Check of Acid-Type Battery (12 volt).

NOTE: Do not attempt to measure individual cell voltage by "jabbing" a voltmeter probe through the battery cover.

*Specific Gravity	Percentage of Charge in Battery	**Time Required to Charge Battery at 5 Amp Hour Rate		
		24 Amp Hours	32 Amp Hours	50 Amp Hours
1.140	Discharged	5 hours	7 hours	10 hours
1.170	25% Charged	4 hours	5 hours	8 hours
1.200	50% Charged	3 hours	5 hours	4 hours
1.230	75% Charged	1 hours	2 hours	3 hours
1.260	100% Charged			

*This may vary from battery manufacturer's specifications.

**These are approximations. Time may vary due to cell conditions, battery construction, heat, etc.

NOTE: The approximate charging time can be calculated by dividing the Amp-Hour rate of the battery by the Amp-Hour charging rate of charger. (For example: a 55 amp-hour battery on a 5 amp hour charger will take about 11 hours to charge.) The slower charging rate, the easier it is on the battery, and the more thoroughly you will dissolve the sulfate that has collected. Generally a charge rate of 5-7 amps per hour is ideal.

1. Using a battery tester voltmeter, hook up the battery and adjust for 3 times the amp-hour rating of the battery.
2. After 15 seconds (no longer) read the voltmeter. If the voltage is over 9.6 volts check the specific gravity. If reading is below 1.230, charge the battery.

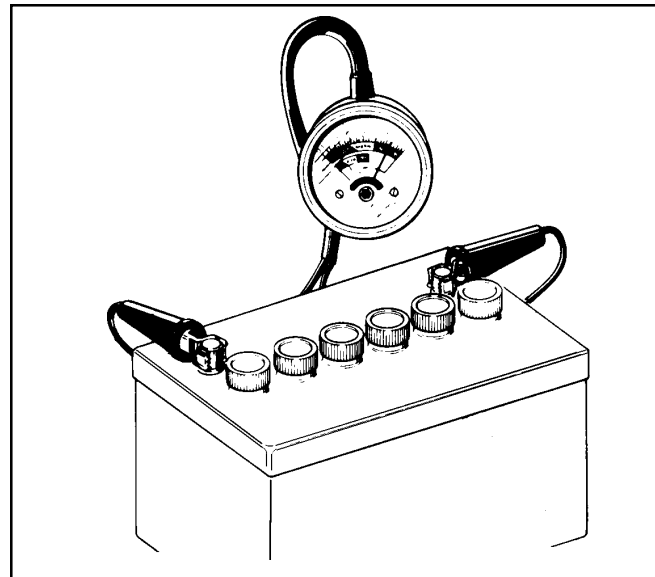

SPECIFIC GRAVITY CHECK. Use a hydrometer to determine that there is at least 75% charge in the battery.

CAUTION: Electrolyte solution contains sulfuric acid. Handle with care since spilled liquid is very corrosive to skin and clothing. Use protective eye cover.

1. Remove caps and check water level, if below battery plates, add water and recheck battery after the water has mixed with the electrolyte after about 4 hours use with engine charge.
2. Put the hydrometer into battery and draw electrolyte into barrel.
3. Make sure the hydrometer float rides freely in electrolyte. Clean inside of barrel with soap and water if float persistently sticks to side of barrel. Clean and dry before use.
4. Make certain readings on float are at eye level.
5. Adjust reading according to temperature of electrolyte. Add .004 for each 10° (12°C) above 80°F (26°C). or subtract .004 for each 10° (12°C) below 80°F (26°C).

If there is a difference of more than .05 volts between the highest and lowest cells, replace the battery.

If there is less than .05 volts between the highest and lowest cells, charge the battery per the chart. If battery is above 9.6 volts the battery is o.k.

If battery reads less than 9.6 volts after charge, the battery is ready to be replaced.

Use caution in reconnecting the battery cables to the battery. An accidental reversal of polarity can cause damage to the regulator-rectifier.

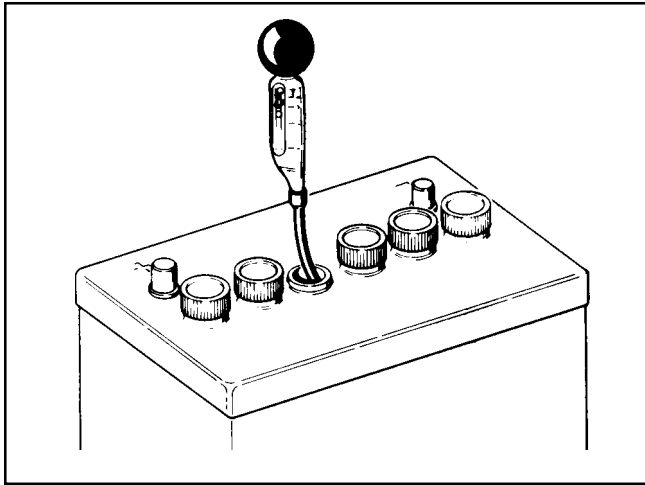

Battery Condition	Specific Gravity
Discharged	1.110 to 1.130
No useful charge	1.140 to 1.160
25%	1.170 to 1.190
50%	1.200 to 1.220
75%	1.230 to 1.250
100%	1.260 to 1.280

SECTION 4. ELECTRICAL CONTROL PANELS

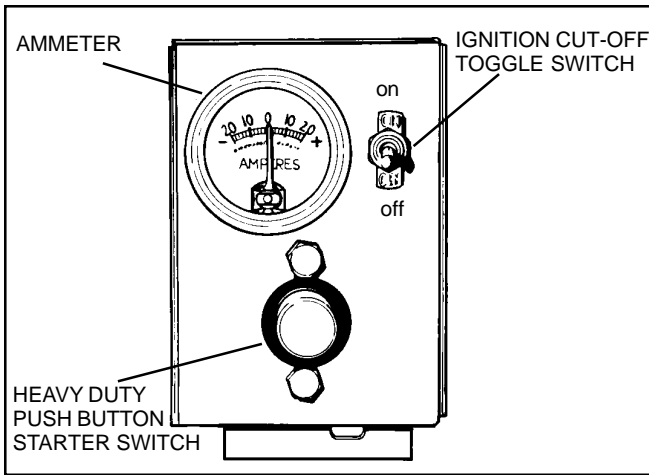

ELECTRICAL CONTROL PANEL SERVICE PART NO. 730155. The test procedures explained below will deal only with the control panel.

Before attempting to locate an apparent defect in the control panel switches or ammeter, insure all connections between control panel, starter and battery are secure and free from corrosion and wire or insulation breaks. Battery should be fully charged or be at a minimum of 75% charge. Engine ignition spark should be checked for an intense spark.

Remove side plates from control panel. Remove engine alternator connector plug from panel connector. Use a volt-ohm-millimeter or battery powered test light for the following tests. **CAUTION** - Remove (+) lead from battery before attempting any of the following tests.

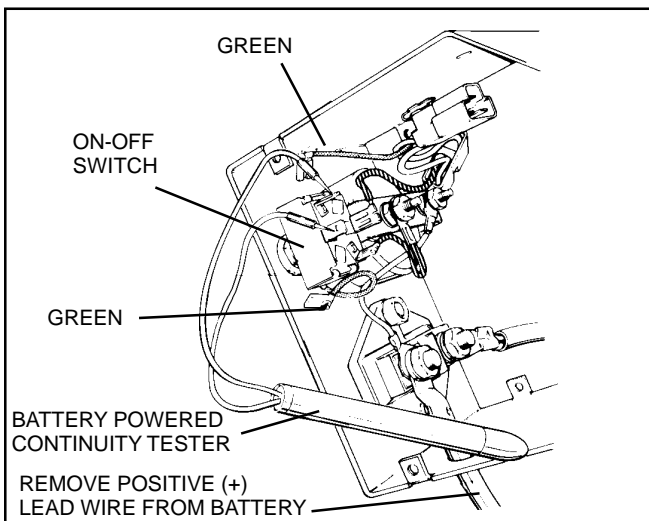

ON-OFF SWITCH IGNITION GROUND CIRCUIT. Remove both the green wires from switch terminals. Attach test leads of tester (Battery type test light or ohmmeter) to switch terminals. Move toggle switch to the "ON" position. No continuity (light should not light) should exist. Leave test leads attached to switch and move switch to "OFF" position. Continuity should exist (light should light). If switch fails to either test, switch must be replaced.

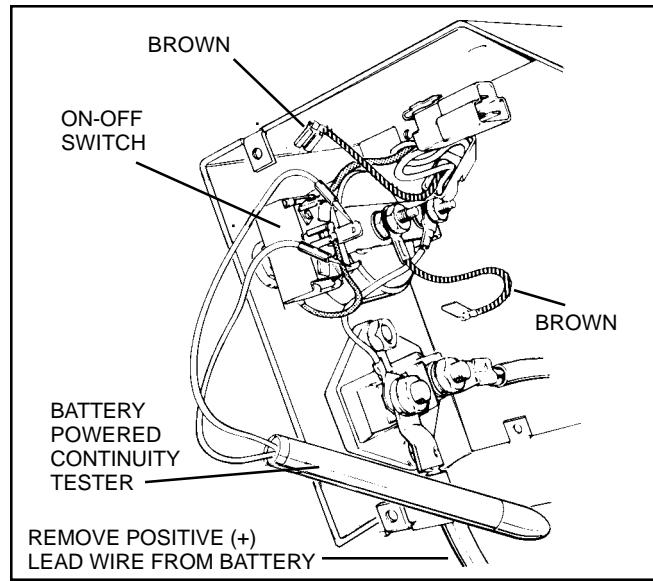

ON-OFF SWITCH - DC RELAY CIRCUIT. Remove both brown wires from switch terminal. Attach test leads to switch terminal. Place switch to the "ON" position. Continuity (test light should light) should exist. Leave test leads attached and move switch to the "OFF" position. Continuity should not exist (test light should not light). If switch fails either of these tests, switch must be replaced.

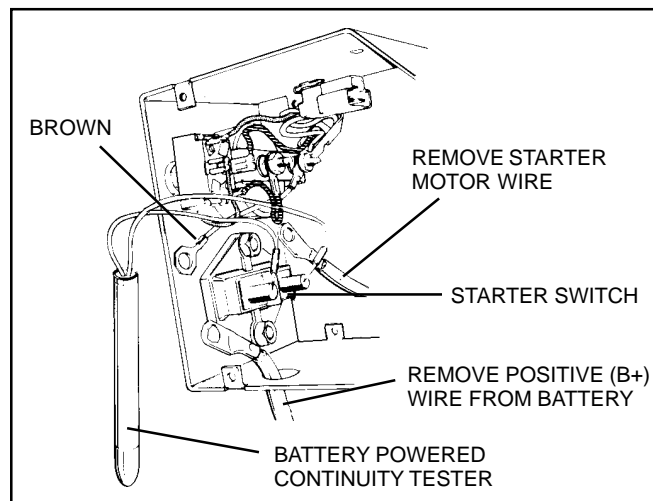

STARTER SWITCH. Remove wires from starter switch. Place test leads on to switch terminals. No continuity should exist (Test light should not light). Leave test leads attached depress starter button. Continuity should exist (Test light should light). If starter switch fails either of these tests, replace switch.

AMMETER. CAUTION The ammeter will not show a charge if the battery is at full charge. The rate of charge will depend on the amount of charge in the battery. The lower the charge in the battery, the higher the reading on the ammeter. If ammeter does not show a charge or discharge, start and stop engine (use electric starter) several times to lower charge of the battery. Observe ammeter and if there is no deflection, proceed with the following test.

To test ammeter remove right side panel. Remove brown wire from "On/Off" switch. Use a volt/ohm/millimeter. Attach one test lead to the terminal the brown wire was removed from, attach other test lead to positive terminal of start switches. Set tester to the ampere scale and start engine. Set throttle control at full throttle and observe meter. If meter registers a charge, system is okay and meter on panel is inoperative. This test can also be made using a good ammeter. Attach a wire to each terminal of the ammeter and hookup as described above. No reading on either meter would indicate a problem with the regulator-rectifier and/or alternator.

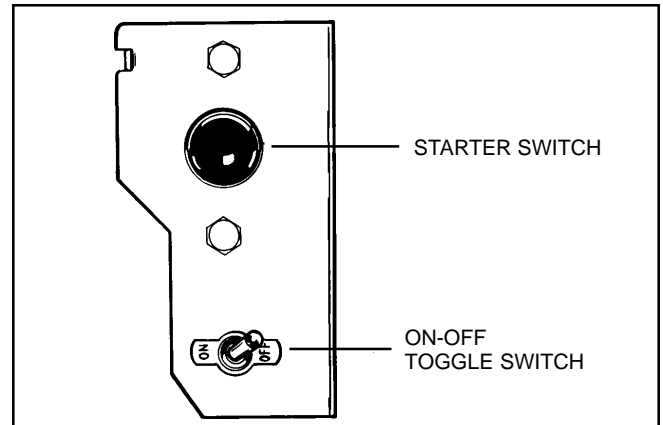

ELECTRICAL CONTROL PANEL SERVICE PART NO. 730198. The following test procedures will be limited to the control panel. Test procedures for electrical components external to this control panel will be found in their respective areas. Before attempting to locate an apparent defect in the control panel switches insure all connections between control panel, starter and battery are secure and free from corrosion and wire or insulation breaks. Battery should be fully charged or be at a minimum of 75% charge. Engine ignition spark should be checked for an intense spark.

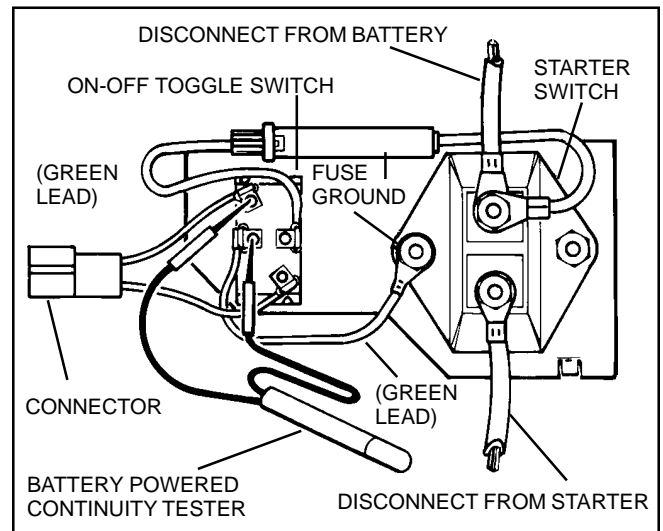
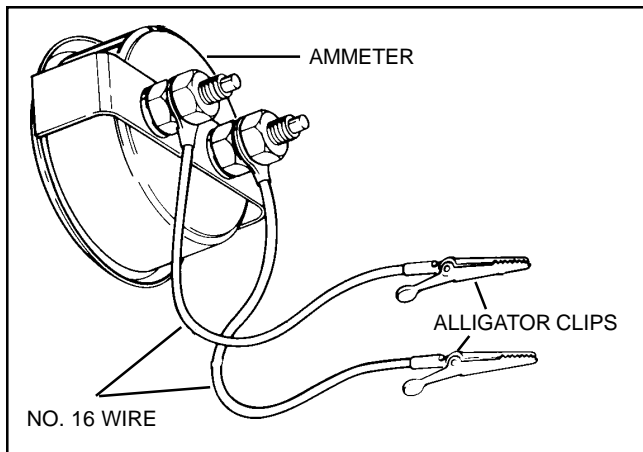
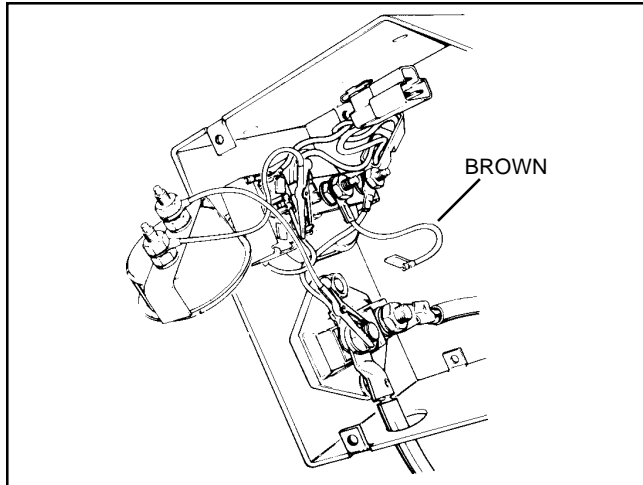

CAUTION - Remove the control panel from the engine bracket then remove (+) lead from battery before attempting any of the following tests.

ON-OFF TOGGLE SWITCH-IGNITION GROUND CIRCUIT. Note: One of several continuity testers may be used. For the following tests a battery powered continuity tester is used.

When disconnecting spade connectors from terminals use care not to damage wire connections or switch terminals. The use of a pair of needlenosed pliers is recommended.

- A. Test for switch continuity of magneto cutout circuit.
 1. Disconnect the two green leads by pulling spade connectors off of terminals.
 2. Place continuity tester probes on each switch terminal.

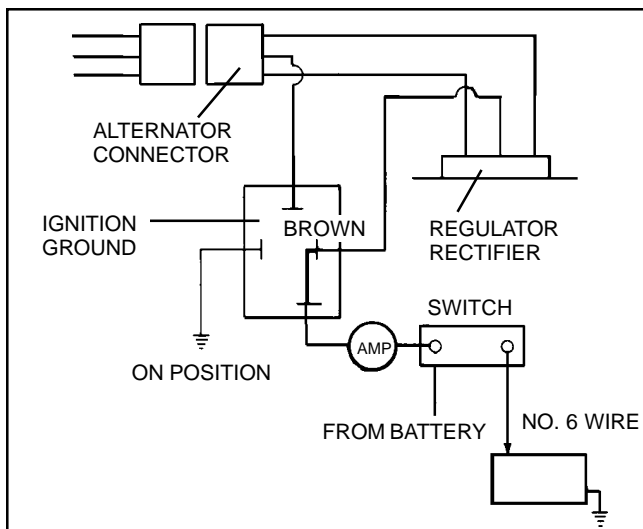

3. With the toggle switch in the "off" position, the test light will light.
4. With the toggle switch in the "on" position, the test light will not light.
5. Position the spade connectors to the original positions.

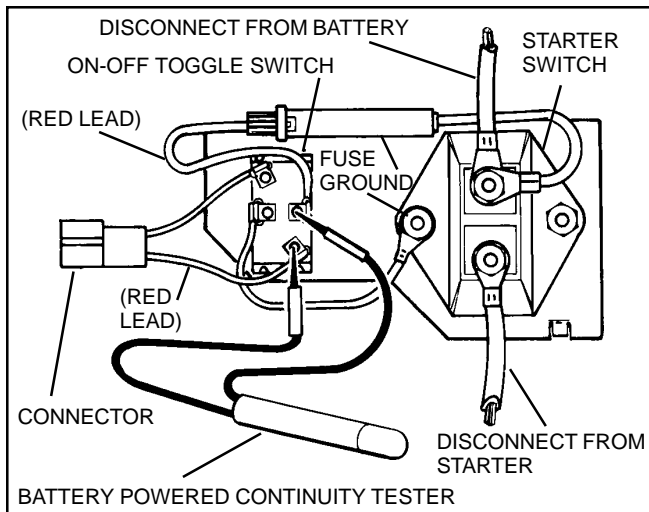

- B. Test for switch continuity of D.C. circuit.
1. Disconnect the spade connector (red wire) from the switch terminal.
 2. Disconnect the other spade connector (red wire) from the switch terminal.
 3. Place continuity tester probes on each switch terminal.
 4. With the toggle switch in the "on" position the test light will light.
 5. With the toggle switch in the "off" position the test light will not light.
 6. Position the spade connectors to the original positions.

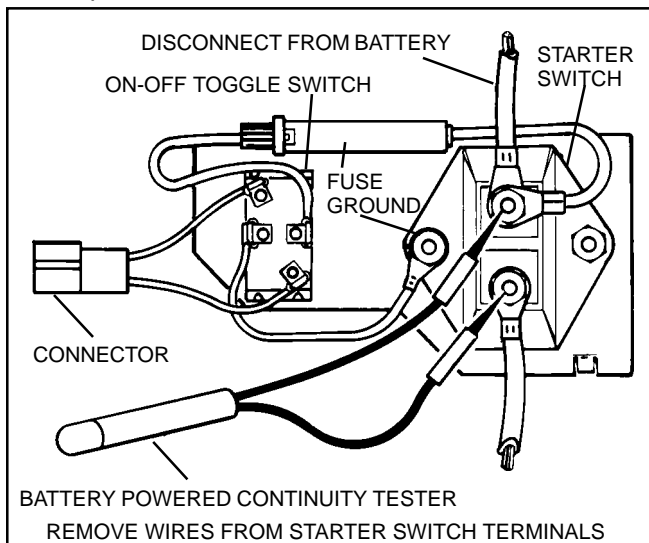

If either of the tests do not give the correct results, replace the switch.

STARTER SWITCH CONTINUITY TEST. Remove wires from starter switch. Place test leads on to switch terminals. No continuity should exist (Test light should not light). Leave test leads attached; depress starter button. Continuity should exist (Test light should light). If starter switch fails either of these tests, replace switch.

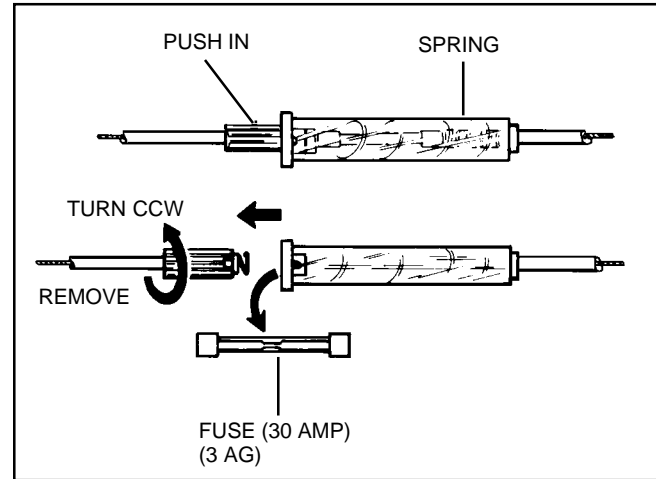

FUSE. To remove the fuse, push the cap in to compress spring at base of fuse holder and with same motion turn the cap counterclockwise (ccw) and pull cap away from holder. Fuse can now be removed from holder. Inspect condition of fuse. If in doubt, perform continuity test on fuse and/or connections in fuse holder. To reinstall, reverse disassembly procedure.

If fuse is defective, replace with a 12 volt/30 amp. size. (3 AG)

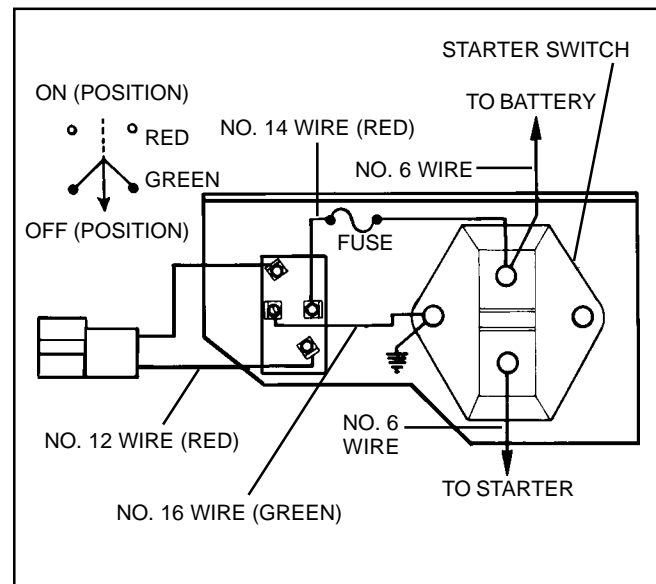

WIRING DIAGRAM. The wiring diagram is shown to show the correct placement of electrical connections, color code and wire gauge. The wire to the battery is supplied by the O.E.M.

TROUBLESHOOTING FOR ELECTRICAL CONTROL PANEL, SERVICE PART NO. 730155.		
TROUBLE	PROBABLE CAUSE	REMEDY
Electric Starter Does Not Crank Engine	<p>Check to determine if crankshaft turns freely; if not, check for binding belts, pulleys, clutches, etc.</p> <p>Check battery connections for corrosion and/or breaks.</p> <p>Weak or bad battery.</p> <p>Push button starter switch.</p> <p>Electric starter.</p> <p>Panel wiring.</p>	<p>Relieve load on crankshaft. Disengage associated equipment clutches, belts or pulleys.</p> <p>Correct problem.</p> <p>Replace or charge battery if less than 3/4 charged.</p> <p>Replace if inoperative. See Service Instruction on preceding pages.</p> <p>See troubleshooting chart.</p> <p>Correct problem.</p>
Starter Cranks Engine But Engine Does Not Start	<p>Toggle switch.</p> <p>Insure spade connectors are secured to appropriate switch terminals.</p>	<p>If inoperative, replace. See Service Instructions on preceding pages.</p> <p>Correct. See Service Instructions on preceding pages. See "Engine Fails to Start"</p>
Ammeter Does Not Show A Charge (If battery is fully charged, ammeter will not show a charge)	<p>Weak or bad battery.</p> <p>Faulty wiring and/or connections.</p> <p>Shorted or open alternator.</p> <p>Regulator-Rectifier.</p> <p>Ammeter.</p>	<p>Charge or replace.</p> <p>Correct or replace.</p> <p>Replace.</p> <p>Replace.</p> <p>Replace if inoperative. See Service Instruction on preceding pages.</p>
Ammeter Shows A Discharge.	<p>Broken wiring and/or insulation.</p> <p>Toggle switch.</p>	<p>Correct problem.</p> <p>Check and replace if inoperative. See Service Instructions on preceding pages.</p>

TROUBLESHOOTING FOR ELECTRICAL CONTROL PANEL, SERVICE PART NO. 730198.		
TROUBLE	PROBABLE CAUSE	REMEDY
Electric Starter Does Not Crank Engine.	<p>Check to determine if crankshaft turns freely; if not, check for binding belts, pulleys, clutches, etc.</p> <p>Check battery connections for corrosion and/or breaks.</p> <p>Weak or bad battery.</p> <p>Push button starter switch.</p> <p>Electric starter.</p> <p>Panel wiring.</p>	<p>Relieve load on crankshaft. Disengage associated equipment clutches, belts or pulleys.</p> <p>Correct problem.</p> <p>Replace or charge battery if less than 3/4 charged.</p> <p>Replace if inoperative. See Service Instruction on preceding pages.</p> <p>See troubleshooting chart.</p> <p>Correct problem.</p>
Starter Cranks Engine But Engine Does Not Start.	<p>Toggle Switch</p> <p>Insure spade connectors are secured to appropriate switch terminals.</p>	<p>If inoperative, replace. See Service Instruction on preceding pages.</p> <p>Correct problem.</p>

CHAPTER 9. TROUBLESHOOTING

TROUBLESHOOTING

Below is a list of common problems and remedies. Follow a uniform procedure to locate and eliminate the causes.

Cause	Remedy
A. ENGINE FAILS TO START OR STARTS WITH DIFFICULTY	
No fuel in tank. Shut-off valve closed. Obstructed fuel line. Tank cap vent obstructed. Water in fuel. Engine over-choked. Improper carburetor adjustment. Loose or defective magneto wiring. Faulty ignition unit. Spark plug fouled. Spark plug porcelain cracked. Poor compression. No spark at plug. Electric starter does not crank engine.	Fill tank with clean, fresh fuel. Open valve Clean fuel screen and line. If necessary, remove and clean carburetor. Open vent in fuel tank cap. Drain tank. Clean carburetor and fuel lines. Dry spark plug electrodes. Fill tank with clean, fresh fuel. Close fuel shut-off and pull starter until engine starts. Reopen fuel shut-off for normal fuel flow. Adjust carburetor. Check magneto wiring for shorts or grounds; repair if necessary. Check ignition unit. Solid State. Check points, timing on standard ignition units. Clean and regap spark plug. Replace spark plug. Check compression. Disconnect ignition cut-off wire at the engine. Crank engine. If spark at spark plug, ignition switch, safety switch or interlock switch is inoperative. If no spark, check magneto. Check wires for poor connections, cuts, or breaks. See 12 volt starter trouble shooting chart page.
B. ENGINE KNOCKS	
Carbon in combustion chamber. Loose or worn connecting rod. Loose flywheel. Worn cylinder. Improper Magneto Timing. Improperly set ignition unit. Excessive main bearing end play.	Remove cylinder head and clean carbon from head and piston. Replace connecting rod. Check flywheel key and keyway; replace parts if necessary. Tighten flywheel nut to proper torque (See Table of Specifications). Recondition cylinder or replace. Time ignition. Check ignition unit. Readjust to correct crankshaft end play.

C. ENGINE MISSES UNDER LOAD	
Cause	Remedy
Spark plug fouled.	Clean and regap spark plug.
Spark plug porcelain cracked.	Replace spark plug.
Improper spark plug gap.	Regap spark plug.
Pitted magneto breaker points.	Clean and dress breaker points. Replace badly pitted breaker points.
Magneto breaker arm sluggish.	Clean and lubricate breaker point rod and arm. Check for spring tension.
Faulty condenser.	Check condenser on a tester; replace if defective.
Improper carburetor adjustment.	Adjust carburetor.
Improper valve clearance.	Adjust valve clearance.
Weak valve spring.	Replace valve spring.
D. ENGINE LACKS POWER	
Choke partially closed.	Open choke.
Improper carburetor adjustment.	Adjust carburetor.
Magneto improperly timed.	Time engine.
Loss of compression.	Check compression.
Lack of lubrication.	Fill crankcase to the proper level.
Air cleaner restricted.	Clean or replace air cleaner.
Valves leaking.	Grind valves.
Valve timing inaccurate.	Check timing marks on camshaft and crankshaft gear.
Carburetor dirty or damaged.	Clean, repair carburetor. See Carburetor Chapter 2.
Ignition system malfunction.	Check and repair system.
E. ENGINE OVERHEATS	
Engine improperly timed.	Time engine.
Carburetor improperly adjusted (lean).	Adjust carburetor.
Air flow obstructed.	Remove any obstructions from air passages in shrouds.
Excessive load on engine.	Check operation of associated equipment. Reduce excessive load.
Carbon in combustion chamber.	Remove cylinder head and clean carbon from head and piston.
Lack of lubrication.	Fill crankcase to proper level.
F. ENGINE SURGES OR RUNS UNEVENLY.	
Fuel tank cap vent hole clogged.	Open vent hole.
Governor parts sticking or binding.	Clean, and if necessary repair governor parts.
Carburetor throttle linkage or throttle shaft and/or butterfly binding or sticking.	Clean, lubricate, or adjust linkage and deburr throttle shaft or butterfly.

Cause	Remedy
<p>Governor not properly adjusted.</p> <p>Carburetor not properly adjusted.</p> <p>Intermittent spark at spark plug.</p>	<p>Adjust governor.</p> <p>Adjust carburetor.</p> <p>Disconnect ignition cut-off wire at the engine. Crank engine. If spark, check ignition switch, safety switch and interlock switch. If no spark, check magneto. Check wires for poor connections cuts or breaks.</p>
G. ENGINE VIBRATES EXCESSIVELY	
<p>Engine not securely mounted.</p> <p>Bent crankshaft.</p> <p>Associated equipment out of balance.</p> <p>Counterbalance counterweights not properly aligned.</p>	<p>Tighten loose mounting bolts.</p> <p>Replace crankshaft.</p> <p>Check associated equipment.</p> <p>Check.</p>
H. ENGINE USED EXCESSIVE AMOUNT OF OIL.	
<p>Engine speed too fast.</p> <p>Oil level too high.</p> <p>Oil filler cap loose or gasket damaged causing spillage out of breather.</p> <p>Breather mechanism damaged or dirty causing leakage.</p> <p>Gaskets or "O" rings damaged or gasket or "O" ring surfaces nicked causing oil to leak out.</p> <p>Valve guides worn.</p> <p>Cylinder wall worn or glazed allowing oil to pass rings into combustion chamber.</p> <p>Piston rings and grooves worn excessively.</p> <p>Piston fit too loose.</p> <p>Piston oil control ring return holes clogged.</p> <p>Oil passages obstructed.</p>	<p>Using tachometer adjust engine RPM to specification.</p> <p>Check level turn dipstick cap tightly into receptacle for accurate level reading.</p> <p>Replace ring gasket under cap and tighten cap securely.</p> <p>Replace breather assembly.</p> <p>Install new gaskets or "O" rings.</p> <p>Ream valve guide oversize and install 1/32" (.787 mm) oversize valve.</p> <p>Deglaze cylinder as necessary.</p> <p>Reinstall new rings and check land clearance and correct as necessary.</p> <p>Measure and replace as necessary.</p> <p>Remove oil control ring and clean return holes.</p> <p>Clean out all oil passages.</p>
I. OIL SEAL LEAKS	
<p>Seal hardened or worn.</p> <p>Crankshaft seal contact surface is slightly scratched causing seal to wear excessively.</p> <p>Crankshaft bearing under seal is worn excessively causing crankshaft to move.</p> <p>Seal outside seat (oil seal bore) in cylinder or side cover is damaged allowing oil to seep around outer edge of seal.</p> <p>New seal installed without correct seal driver and not seating squarely in cavity.</p>	<p>Replace seal.</p> <p>Crankshaft seal rubbing surface must be smoothed before installing new seal. Use a fine crocus cloth. Care must be taken when removing seals.</p> <p>Check crankshaft bearings for wear and replace if necessary.</p> <p>Visually check seal receptacle (oil seal bore) for damage. Replace P.T.O. cylinder cover or small cylinder cover on the magneto end, if necessary.</p> <p>Replace with new seal using proper tools and methods.</p>

Cause	Remedy
<p>New seal damaged upon installation.</p> <p>Bent crankshaft causing seal to leak.</p> <p>Oil seal driven too far into cavity.</p>	<p>Use proper seal protector tools and methods for installing another new seal.</p> <p>Check crankshaft for straightness and replace if necessary. (Never straighten a bent crankshaft)</p> <p>Remove seal and replace with new seal using the correct driver tool and procedures.</p>
J. BREATHER PASSING OIL	
<p>Engine speed too fast.</p> <p>Loose oil fill cap or gasket damaged or missing.</p> <p>Oil level too high.</p> <p>Breather mechanism damaged.</p> <p>Breather mechanism dirty.</p> <p>Piston ring end gaps aligned.</p> <p>Drain hole in breather box clogged.</p> <p>Breather mechanism loose or gaskets leaking.</p> <p>Damaged or worn oil seals on end of crankshaft.</p> <p>Rings not seated properly.</p> <p>Breather assembly not assembled correctly on engine.</p> <p>Cylinder cover gasket leaking.</p>	<p>Use tachometer to adjust correct RPM.</p> <p>Install new ring gasket under cap and tighten securely.</p> <p>Check oil level Turn dipstick cap tightly into receptacle for accurate level reading. DO NOT fill above full mark.</p> <p>Replace.</p> <p>Clean thoroughly in solvent.</p> <p>Rotate end gaps so as to be staggered 90° apart.</p> <p>Clean hole with wire to allow oil to return to crankcase.</p> <p>Install new gaskets and tighten securely.</p> <p>Replace seals.</p> <p>Check for worn or out of round cylinder. Replace rings. Break in new rings with engine working under a varying load. Rings must be seated under high compression or in other words under varied load conditions.</p> <p>Refer to breather section.</p> <p>Replace cover gaskets.</p>

K. TROUBLE SHOOTING CARBURETION	
POINTS TO CHECK FOR CARBURETOR MALFUNCTION	
Trouble	Correction
Carburetor out of adjustment	4-12-13-14-15-17-22
Engine will not start	1-2-3-4-5-6-7-9-12-13
Engine will not accelerate	3-4-12-13-14-26
Engine hunts (at idle or high speed)	4-5-9-10-11-12-13-14-22-23-26
Engine will not idle.....	5-9-10-12-14-15-16-22-23-24-26
Engine lacks power at high speed	3-4-7-9-12-13-22-23-26
Carburetor floods	5-8-19-23-24
Carburetor leaks	7-8-11-20-25-26
Engine overspeeds	9-10-12-16-17-20-22
Idle speed is excessive	9-10-15-16-17-20-22
Choke does not open fully	9-10-17
Engine starves for fuel at high speed (leans out)..	1-2-4-5-7-12-17-19-21-23
Carburetor runs rich with main adjustment needle shut off	8-12-19-20-21-23
Performance unsatisfactory after being serviced ..	1 thru 14 and 17 thru 23

- | | |
|--|--|
| 1. Open fuel shut-off valve at fuel tank, fill tank with fuel. | 14. Adjust idle mixture adjustment screw. Check to see that it is the correct screw. |
| 2. Examine and clean fuel line and filter (where applicable). | 15. Adjust idle speed screw. |
| 3. Check ignition, spark plug and compression. | 16. Check position of choke and throttle plates. |
| 4. Clean air cleaner, service as required. | 17. Adjust control cable or linkage to assure full choke and carburetor control. |
| 5. Dirt or restriction in fuel system, clean tank and fuel strainers, check for kinks or sharp bends. | 18. Clean carburetor after removing all non-metallic parts that are serviceable. Trace all passages. |
| 6. Check for stale fuel or water in fuel, fill with fresh fuel. | 19. Check inlet needle and seat condition and proper installation. |
| 7. Examine fuel line and pick-up for sealing at fittings. | 20. Check sealing of welch plugs, cups, plugs and gaskets. |
| 8. Check and clean atmospheric vent holes. | 21. Check fuel pump operation of pulse pump, clean the pulse line after removing it from the pump and engine fittings. |
| 9. Examine throttle and choke shafts for binding or excessive play, remove all dirt or paint, replace shaft. | 22. Adjust governor linkage. |
| 10. Examine throttle and choke return springs for operation. | 23. Adjust float setting. |
| 11. Examine idle and main mixture adjustment screws and "O" rings for cracks or damage. | 24. Check float shaft for wear and float for leaks or dents. |
| 12. Adjust main mixture adjustment screw. Check to see that it is the correct screw. | 25. Check seal for fuel drain or bowl gasket. |
| 13. Examine main nozzle and replace with service nozzle. | 26. Is carburetor operating at excessive angle, 31° or more ? |

CHAPTER 10. 8 H.P. & LARGER ENGINE AND TORQUE SPECIFICATIONS ALSO VALVE-IN-HEAD SPECIFICATIONS AND TORQUES

SECTION 1. CROSS REFERENCE LIST FOR TABLE OF SPECIFICATIONS

Craftsman Engine Model	See Model	Craftsman Engine Model	See Model	Craftsman Engine Model	See Model	Craftsman Engine Model	See Model
143.558012	HH80	143.588032	HH80	143.629052	HH100		
143.558022	HH80	143.589012	HH100	143.629062	HH100		
143.558032	HH80	143.589022	HH100				
143.558052	HH80	143.589032	HH100	143.629072	HH100		
143.559012	HH100	143.589042	HH100				
143.559022	HH100	143.589052	HH100	143.632022	HH120		
143.559032	HH100	143.589072	HH100				
143.559042	HH100	143.592012	HH120	143.632032	HH120		
143.562012	HH120	143.592022	HH120	143.632042	HH120		
143.562022	HH120	143.592032	HH120				
143.562032	HH1200	143.592052	HH120	143.639012	HH100		
143.568032	HH80	143.592062	HH120				
143.569022	HH100	143.592072	HH120	143.642012	HH120		
143.569032	HH100	143.592082	HH120				
143.569042	HH100	143.598012	HH80	143.642022	HH120		
143.569052	HH100	143.599012	HH100	143.642032	HH120		
143.569082	HH100	143.599022	HH100	143.642042	HH120		
143.572012	HH120	143.599042	HH100	143.649012	HH100		
143.572022	HH120	143.599052	HH100	143.649022	HH100		
143.572032	HH120	143.599062	HH100	143.652012	HH120		
143.572042	HH120	143.602012	HH120	143.652022	HH120		
143.572052	HH120	143.602022	HH120	143.652032	HH120		
143.572062	HH120	143.602032	HH120	143.652042	HH120		
143.572092	HH120	143.602052	HH120	143.652052	HH120		
143.572102	HH120	143.602062	HH120	143.652062	HH120		
143.578012	HH80	143.602072	HH120	143.652072	HH120		
143.578022	HH80	143.602082	HH120	143.659012	HH100		
143.578052	HH80	143.602092	HH120	143.659022	HH100		
143.578062	HH80	143.602102	HH120	143.659032	HH100		
143.578072	HH80	143.602112	HH120	143.662012	HH120		
143.579012	HH100	143.602122	HH120	143.669012	HH100		
143.579022	HH100	143.608012	HH80	143.672012	HH120		
143.579032	HH100	143.608022	HH80	143.672022	HH120		
143.579042	HH100	143.608032	HH80	143.672032	HH120		
143.579052	HH100	143.609022	HH100	143.672042	HH120		
143.579062	HH100	143.609032	HH100	143.672052	HH120		
143.579072	HH100	143.609042	HH100	143.672062	HH120		
143.579082	HH100	143.609052	HH100	143.672072	HH120		
143.579092	HH100	143.609072	HH100	143.676082	HH100		
143.579102	HH100	143.612012	HH120	143.679012	HH100		
143.579112	HH100	143.612022	HH120	143.679022	HH100		
143.579132	HH100	143.619012	HH100	143.679032	HH100		
143.582012	HH120	143.622012	HH120	143.712012	HH120		
143.582022	HH120	143.622022	HH120	143.712022	HH120		
143.582032	HH120	143.622032	HH120	143.712032	HH120		
143.582042	HH120	143.622042	HH120	143.712042	HH120		
143.582052	HH120	143.622052	HH120	143.760012	HH120		
143.582062	HH120	143.622062	HH120	143.780012	HH120		
143.582072	HH120	143.622072	HH120				
143.582082	HH120	143.622082	HH120				
143.582092	HH120	143.622092	HH120				
143.582102	HH120	143.622102	HH120				
143.582112	HH120	143.628012	HH80				
143.582122	HH120	143.628022	HH80				
143.582132	HH120	143.629012	HH100				
143.582142	HH120	143.629022	HH100				
143.582172	HH120	143.629032	HH100				
143.588012	HH80	143.629042	HH100				

Model	HH80		HH100		HH120		
	U.S.	Metric	U.S.	Metric	U.S.	Metric	
Displacement	23.7	384.4cc	23.7	284.4cc	27.66	453.4 cc	
Stroke	2-3/4"	69.85mm	2-3/4"	69.85mm	2-7/8"	73.025mm	
Bore	3.3120 3.3130	84.125 84.150	3.3120 3.3130	84.125 84.150	3.500 3.501	88.900mm 88.925mm	
Timing Dimension	TDC-Start .095 Run	2.41	TDC-Start .095 Run	2.41	TDC-Start .095 Run	2.41mm	
Point Gap	.020	.508	.020	.508	.020	.508	
Spark Plug Gap	.028 .033	.711 .838	.028 .033	.711 .838	.028 .033	.711mm .838mm	
Valve Clearance	Intake Exhaust	.010 .020	.254 .508	.010 .020	.254 .508	.010 .020	.254mm .508mm
Valve Seat Angle	46°		46°		46°		
Valve Seat Width	.042 .052	.042 .052	.042 .052	1.067 1.321	.042 .052	1.067mm 1.321mm	
Valve Face Angle	45°	45°	45°	45°	45°	45°	
Valve Face Width	.089 .099	2.261 2.515	.089 .099	2.261 2.515	.089 .099	2.261 2.515	
Valve Lip Width	.06	1.524	.06	1.524	.06	1.524	
Valve Spring Free Length	1.885	47.879	1.885	47.879	1.885	47.879	
Valve Guides STD Diameter	.312 .313	7.925 7.950	.312 .313	7.925 7.950	.312 .313	7.925 7.950	
Valve Guides Over-Size Dimensions	.343 .344	8.712 8.738	.343 .344	8.712 8.738	.343 .344	8.712 8.738	
Dia. Crankshaft Conn. Rod Journal	1.3750 1.3755	34.925 34.938	1.3750 1.3755	34.925 34.938	1.3750 1.3755	34.925 34.938	
Maximum Conn. Rod Dia.Crank Bearing	Maximum 1.3765	34.963	Maximum 1.3765	34.963	Maximum 1.3765	34.963	
Shaft Seat Dia. for Roller Bearings	1.1865 1.1870	30.137 30.150	1.1865 1.1870	30.137 30.150	1.1865 1.1870	30.137 30.150	
Crankshaft End Play	None		None		None		
Piston Diameter	3.3080 3.3100	84.023 84.074	3.3080 3.3100	84.023 84.074	3.4950 3.4970	88.773 88.824	

NOTE: All dimensions are in inches and millimeters unless noted.

Model	HH80		HH100		HH120	
	U.S.	Metric	U.S.	Metric	U.S.	Metric
Piston Pin Diameter	.6873 .6875	17.457 17.463	.6873 .6875	17.457 17.463	.6873 .6875	17.457 17.463
Width Comp. Ring Groove	.0950 .0960	2.413 2.438	.0950 .0960	2.413 2.438	.0950 .0960	2.413 2.438
Width Oil Ring Groove	.1880 .1900	4.775 4.826	.1880 .1900	4.775 4.826	.1880 .1890	4.775 4.826
Side Clearance Ring Groove	.0020 .0035	.051 .889	.0020 .0035	.051 .889	.0020 .0035	.051 .889
Ring End Gap	.007 .020	.178 .508	.007 .020	.178 .508	.007 .020	.178 .508
Top Piston Land Clearance	.0305 .0335	.775 .851	.030 .035	.762 .889	.031 .036	.787 .914
Piston Skirt Clearance	.002 .005	.051 .127	.002 .005	.051 .127	.003 .006	.076 .127
Camshaft Bearing Diameter	.6235 .6240	15.837 15.850	.6235 .6240	15.837 15.850	.6235 .6240	15.837 15.850
Cam Lobe Diameter Nose to Heel	1.3045 1.3085	33.134 33.326	1.3045 1.3085	33.134 33.236	1.3045 1.3085	33.134 33.236
Magneto Air Gap	.006 .010	.152 .254	.006 .010	.152 .254	.006 .010	.152 .254

Model	VH80		VH100		
	U.S.	Metric	U.S.	Metric	
Displacement	23.7	388.4 cc	23.7	388.4 cc	
Stroke	2-3/4"	69.85	2-3/4"	69.85	
Bore	3.3120 3.3130	84.125 84.150	3.3120 3.3130	84.125 84.150	
Timing Dimension	Solid State		Solid State		
Point Gap	Solid State		Solid State		
Spark Plug Gap	.035	.889	.035	.889	
Valve Clearance	Intake Exhaust	.010 .020	.254 .508	.010 .020	.254 .508
Valve Seat Angle	46°	46°	46°	46°	
Valve Seat Width	.042 .052	1.067 1.321	.042 .052	1.067 1.321	

Model	VH80		VH100	
	U.S.	Metric	U.S.	Metric
Valve Face Angle	45°	45°	45°	45°
Valve Face Width	.089 .099	2.261 2.515	.089 .099	2.261 2.515
Valve Lip Width	.06	1.524	.06	1.524
Valve Spring Free Length	1.885	47.879	1.885	47.879
Valve Guides STD Diameter	.312 .313	7.925 7.950	.312 .313	7.925 7.950
Valve Guides Over-Size Dimensions	.344 .345	8.738 8.763	.344 .345	8.738 8.763
Diameter Crankshaft Conn. Rod Journal	1.3750 1.3755	34.925 34.938	1.3750 1.3755	34.925 34.938
Maximum Conn. Rod Dia. Crank Bearing	1.3761	44.097	1.3761	44.097
Shaft Seat Dia. for Roller Bearings	1.1865 1.1870	30.137 30.150	1.1865 1.1870	30.137 30.150
Crankshaft End Play	None		None	
Piston Diameter	3.308 3.310	84.023 84.074	3.308 3.310	84.023 84.074
Piston Pin Diameter	.6873 .6875	17.457 17.463	.6873 .6875	17.457 17.463
Width Comp. Ring Groove	.0950 .0960	2.41 2.438	.0950 .0960	2.41 2.438
Width Oil Ring Groove	.1800 .1900	4.572 4.826	.1800 .1900	4.572 4.826
Side Clearance Ring Groove	.0025 .0030	.635 .076	.0025 .0030	.635 .076
Ring End Gap	.010 .020	.254 .508	.010 .020	.254 .508
Top Piston Land Clearance	.0305 .0335	.775 .851	.0305 .0335	.775 .851
Piston Skirt Clearance	.003	.076	.003	.076
Camshaft Bearing Diameter	.6235 .6240	15.837 15.850	.6235 .6240	15.837 15.850
Cam Lobe Diameter Nose to Heel	1.3045 1.3085	33.134 33.236	1.3045 1.3085	33.134 33.236
Magneto Air Gap	.006 .010	.152 .254	.006 .010 Solid State	.152 .254

NOTE: All dimensions are in inches and millimeters unless noted.

SECTION 2. TORQUE SPECIFICATIONS
8 H.P. & LARGER ENGINES (EXCEPT VALVE-IN-HEAD)

	INCH POUNDS	NEWTON METER
Cylinder Head Bolts	180 - 240	20.3 - 27.1
Connecting Rod Lock Nuts	86 - 110	9.7 - 12.4
Mounting Flange or Cylinder Cover	100 - 130	11.3 - 14.7
Flywheel Nut	600 - 660	67.8 - 74.6
Spark Plug	220 - 280	24.9 - 31.6
Carburetor to Cylinder	72 - 96	8.1 - 10.9
Air Cleaner to Elbow	15 - 25	1.7 - 2.8
Air Cleaner Bracket to Carburetor	15 - 25	1.7 - 2.8
Tank Bracket to Housing	35 - 50	4.0 - 5.7
Tank Bracket to Cylinder (5/16" Lower)	150 - 200	17 - 22.6
Tank Bracket to Head Bolt	150 - 200	17 - 22.6
Starter-Top Mount Recoil	40 - 60	4.5 - 6.8
Belt Guard to Blower Housing	25 - 35	2.8 - 4.0
Flywheel Screen & Pulley	72 - 96	8.1 - 10.9
Stationary Point Screw	15 - 20	1.7 - 2.3
Blower Housing Baffle to Cylinder	72 - 96	8.1 - 10.9
Blower Housing to Baffle or Cylinder	48 - 72	5.4 - 8.1
Breaker Point Cover	15 - 25	1.7 - 2.8
Magneto Stator Mounting	72 - 96	8.1 - 10.9
Breather to Cylinder	20 - 25	2.3 - 2.8
Oil Drain Plug 3/8 18	80 - 100	9.0 - 11.3
Blower Housing Extension to Cylinder	72 - 96	8.1 - 10.9
Stub Shaft Bolts to Flywheel	100 - 125	11.3 - 14.1
Motor Generator all Mounting Bolts	65 - 100	7.4 - 11.3

NOTE: Divide by 12 for foot pounds.

SECTION 3. VALVE-IN-HEAD ENGINE SPECIFICATIONS

Description	Model OH120		Model OH140		Model OH150		Model OH160		Model OH180	
	U.S.	Metric	U.S. See Note	Metric	U.S. See Note	Metric	U.S. See Note	Metric	U.S.	Metric
Displacement	21.1	346 cc	23.7	388 cc	27.66	453 cc	27.66	453 cc	30.0	492 cc
Stroke	2.75	69.80	2.75	69.80	2.875	69.80	2.875	69.80	2.875	69.80
Bore	3.125 3.126	79.375 79.400	3.312 3.313	84.125 84.150	3.500 3.501	88.900 88.925	3.500 3.501	88.900 88.925	3.625 3.626	92.075 92.100
Spark Plug Gap	.030	.762	.030	.762	.030	.762	.030	.762	.030	.762
Valve Clearance Intake Exhaust	.005 .010	.0127 .254	.005 .010	.0127 .254	.005 .010	.0127 .254	.005 .010	.0127 .254	.005 .010	.0127 .254
Valve Seat Angle	46°		46°		46°		46°		46°	
Valve Seat Width	.042 .052	1.067 1.321	.042 .052	1.067 1.321	.042 .052	1.067 1.321	.042 .052	1.067 1.321	.042 .052	1.067 1.321
Valve Face Angle	45° +	45°	45° +	45°	45° +	45°	45° +	45°	45° +	45°
Valve Face Width	.094	2.388	.133	3.378	.133	3.378	.133	3.378	.133	3.378
Valve Lip Width	.06	1.524	.06	1.524	.06	1.524	.06	1.524	.06	1.524
Valve Spring Free Length	1.915	48.641	1.980	50.292	1.980	50.292	1.980	50.292	1.980	50.292
Valve Guides STD Diameter	.312 .313	7.925 7.950	.312 .313	7.925 7.950	.312 .313	7.925 7.950	.312 .313	7.925 7.950	.312 .313	7.925 7.950
Dia. Crankshaft Conn. Rod Journal	1.3750 1.3755	34.925 34.938	1.3750 1.3755	34.925 34.938	1.3750 1.3755	34.925 34.938	1.3750 1.3755	34.925 34.938	1.3750 1.3755	34.925 34.938
Maximum Conn. Rod Dia. Crank Bearing	1.3765	34.963	1.3765	34.963	1.3765	34.963	1.3765	34.963	1.3765	34.963
Shaft Seat Dia. for Roller Bearings	1.1865 1.1870	30.137 30.150	1.1865 1.1870	30.137 30.150	1.1865 1.1870	30.137 30.150	1.1865 1.1870	30.137 30.150	1.1865 1.1870	30.137 30.150
Crankshaft End Play	*None .001 .007 Preload	.025 .178	*None .001 .007 Preload	.025 .178	*None .001 .007 Preload	.025 .178	*None .001 .007 Preload	.025 .178	*None .001 .007 Preload	.025 .178
Piston Skirt Diameter	3.121 3.123	79.273 79.324	3.3080 3.3100	84.023 84.074	3.4950 3.4970	88.773 88.824	3.4950 3.4970	88.773 88.824	3.620 3.622	91.948 91.999
Piston Pin Diameter	.6876 .6880	17.465 17.475	.6876 .6880	17.465 17.475	.6876 .6880	17.465 17.475	.6876 .6880	17.465 17.475	.7810 .7812	
Width Comp. Ring Groove	.0950 .0960	2.413 2.438	.0950 .0960	2.413 2.438	.0950 .0960	2.413 2.438	.0950 .0960	2.413 2.438	.0955 .0965	
Width Oil Ring Groove	.1880 .1900	4.775 4.826	.1880 .1900	4.775 4.826	.1880 .1890	4.775 4.826	.1880 .1890	4.775 4.826	.1880 .1895	4.775 4.826

Note: First Model Year was designated as an HH140, 150, 160.

Description	Model OH120		Model OH140		Model OH150		Model OH160		Model OH180	
	U.S.	Metric	U.S.	Metric	U.S.	Metric	U.S.	Metric	U.S.	Metric
Side Clearance Ring Groove Compression	.0015 .0035	.038 .089	.0015 .0035	.038 .089	.0015 .0035	.038 .089	.0015 .0035	.038 .089	.0015 .0035	.038 .089
Ring End Gap	.010 .020	.254 .508	.010 .020	.254 .508	.010 .020	.254 .508	.010 .020	.254 .508	.010 .020	.254 .508
Top Piston Land Clearance	.031 .034	.787 .864	.030 .035	.762 .889	.031 .036	.787 .864	.031 .036	.787 .864	.031 .036	.787 .864
Camshaft Bearing Diameter	.6235 .6240	15.837 15.850	.6235 .6240	15.837 15.850	.6235 .6240	15.837 15.850	.6235 .6240	15.837 15.850	.6235 .6240	15.837 15.850
Cam Lobe Diameter Nose to Heel	1.3117 1.3167	33.317 33.444	1.3117 1.3167	33.317 33.444	1.3117 1.3167	33.317 33.444	1.3117 1.3167	33.317 33.444	1.3117 1.3167	33.317 33.444

CROSS REFERENCE LIST		CROSS REFERENCE LIST	
Craftsman Engine Model	See Model	Craftsman Engine Model	See Model
143.626272	OH160	143.670052	OH160
143.630012	OH160	143.670062	OH160
143.630022	OH160	143.670072	OH160
143.640012	OH160	143.670082	OH140
143.640022	OH160	143.670092	OH140
143.640032	OH160	143.680012	OH140
143.640042	OH160	143.680022	OH140
143.640052	OH160	143.680032	OH160
143.650012	OH160	143.700012	OH180
143.650022	OH160	143.710012	OH160
143.650032	OH160	143.710022	OH140
143.660012	OH160	143.730012	OH160
143.660022	OH160	143.730022	OH140
143.670012	OH140	143.740012	OH140
143.670032	OH160	143.740022	OH160
143.670042	OH140	143.770022	OH180

“Torque specifications listed on this page should not be confused with the torque value observed on engines which have been run. Torque relaxation occurs on all engines from thermal expansion and contraction. The torque specifications take relaxation into account so a sufficient clamping force exists after an engine has been run.”

SECTION 4. TORQUE SPECIFICATIONS VALVE-IN-HEAD

TORQUE SPECIFICATIONS		
	INCH	Nm
Cylinder Head Bolts	180 - 240	20.3 - 27.1
Connecting Rod Screw or Nut	86 - 110	9.7 - 12.4
Mounting Flange Cylinder Cover Screw	100 - 130	11.3 - 14.7
Cylinder Cover Flywheel End	120 - 160	13.6 - 18.1
Flywheel Nut	600 - 660	67.8 - 74.6
P.T.O. Shaft to Flywheel	100 - 125	11.3 - 14.1
Spark Plug	220 - 280	24.9 - 31.6
Intake Pipe to Cylinder	72 - 96	8.1 - 10.9
Carburetor to Intake Pipe	48 - 72	5.4 - 8.1
Air Cleaner Elbow to Carburetor	25 - 35	2.8 - 4.0
Air Cleaner Bracket to Elbow	15 - 25	1.7 - 2.8
Air Cleaner Bracket to Carburetor	15 - 25	1.7 - 2.8
Tank Bracket to Cylinder (5/16" Lower)	150 - 200	17.0 - 22.6
Tank Bracket to Cylinder (1/4")	96 - 120	10.9 - 13.6
Starter-Recoil-Top Mount	40 - 60	4.5 - 6.8
Starter-Electric-Straight Drive	140 - 170	15.8 - 19.2
Rope Start Pulley Mounting Screws	60 - 75	6.8 - 8.5
Rocker Arm Box to Cylinder Head	80 - 90	9.0 - 10.2
Rocker Arm Cover and Breather (Screw to Stud)	15 - 20	1.7 - 2.3
Rocker Arm Adjusting Screw Lock Nut	50 - 70	5.5 - 8.0
Rocker Box Cover to Mtg. Stud	20 - 30	2.3 - 3.4
Magneto Stator Mounting Screw	72 - 96	8.1 - 10.9
Blower Housing to Baffle or Cylinder	48 - 72	5.4 - 8.1
Housing Baffle to Cylinder	72 - 96	8.1 - 10.9
Blower Housing Extension to Cylinder	72 - 96	8.1 - 10.9
Governor Rod Clamp to Rod (Screw and Nut)	15 - 25	1.7 - 2.8
Governor Rod Clamp to Lever (Screw and Nut)	15 - 20	1.7 - 2.3
Ground Wire to Terminal	5 - 10	.6 - 1.1
Toggle Stop Switch Nut	10 - 15	1.1 - 1.7
Oil Drain Plug 3/8 18	80 - 100	9.0 - 11.3
Oil Drain Cap	35 - 50	4.0 - 5.7
Oil Fill Plug (Large Diameter)	Hand Tighten	Hand Tighten

CHAPTER 11. EDUCATIONAL MATERIALS AND TOOLS

VIDEO PROGRAMS

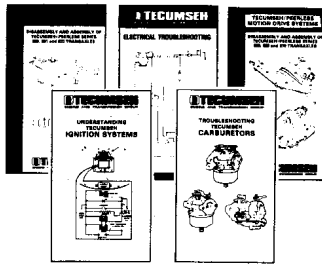

695015

Carburetor Troubleshooting. Covers identification of carburetors used on Tecumseh engines and how to troubleshoot and repair them. VHS only.

695059

Understanding Tecumseh Ignition Systems. A basic program designed to give the small engine technician first hand knowledge of Tecumseh ignition systems so the technician can understand the system and perform repairs to it. VHS only.

695148

Teardown and reassembly of the 900 series transaxles. This video will show a complete step-by-step procedure for teardown and reassembly of the 900, 910 and 920 series transaxles.

695185

Electrical Troubleshooting. This video training program will assist the small engine technician in the proper procedures for troubleshooting electrical systems on outdoor power equipment.

695285

An in-depth look at the 800 series transaxles. Detailing the teardown and reassembly procedures for the 800, 801 and 820 transaxles.

SPECIAL BOOKLETS

INSTRUCTIONAL GUIDE

692738

Assists in the use and understanding of the Tecumseh Master Parts Manual. Illustrates time saving features incorporated into the manual. Explains new carburetor parts breakdown format.

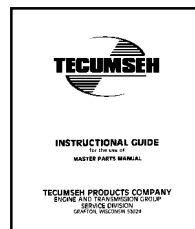

4-CYCLE ENGINE FAILURE ANALYSIS

695590

This booklet is designed as a tool for the average technician to correctly assess the cause of failure.



CARBURETOR TROUBLESHOOTING BOOKLET

695907

This booklet is designed as a quick reference to carburetion problems and related repair procedures.



IGNITION SYSTEMS TROUBLESHOOTING BOOKLET

694903

This booklet contains information on the identification, possible problems and related repair procedures of Tecumseh Ignition Systems.



SPECIAL TOOLS BOOKLET

694862

This booklet depicts all specialty tools offered by Tecumseh which can be used on 2 and 4 cycle engines and Peerless units.



QUICK REFERENCE CHART BOOKLET

695933

This booklet contains the quick reference information found on Tecumseh wall charts.

This booklet is designed to be used as a work bench quick reference guide when servicing Tecumseh engines and motion drive systems.



TESTER BOOKLETS

694529

Test procedures for Tecumseh electrical components using Graham-Lee Tester 31-SM or 31-SMX-H.



694530

Test procedures for Tecumseh electrical components using Merco-O-Tronic Tester 9800. (Tests are similar for 98, 98A and 79.)



TOOL KIT 670195D

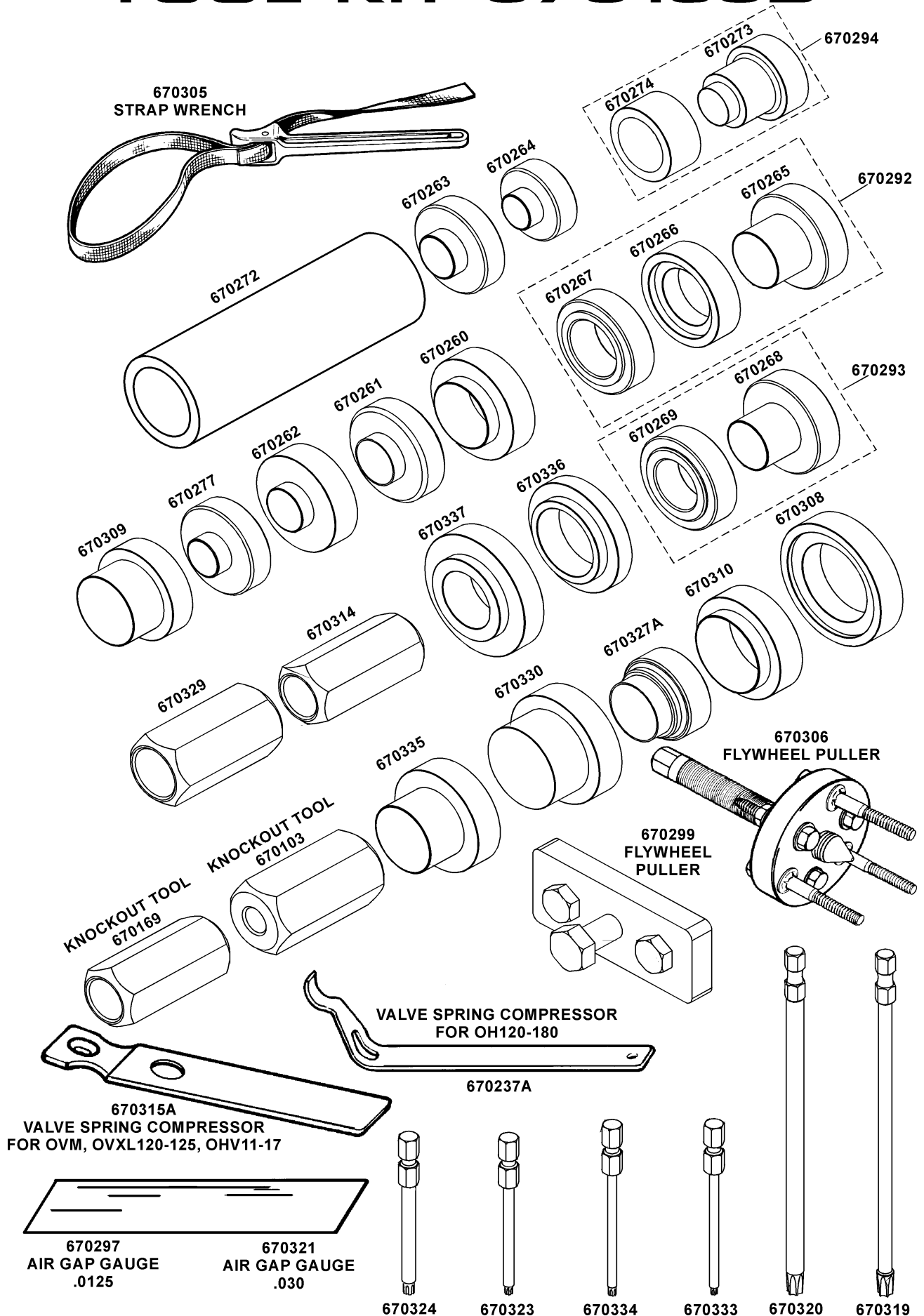

TAPER GAP GAUGE

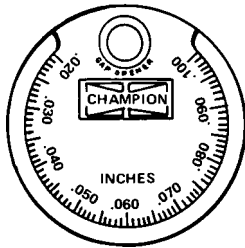

No. 670256 - Taper Gap Gauge

VALVE LAPPING TOOL

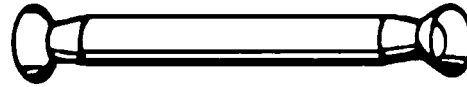

No. 670154 - Valve lapping tool.

1/32" OVERSIZE GUIDE REAMER



No. 670284 - HH & VH80-120 and OH120-180

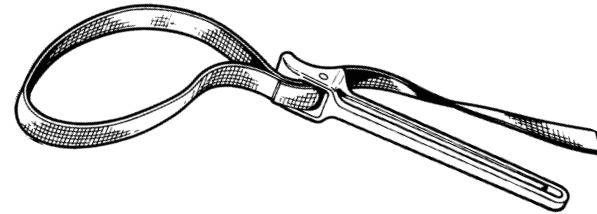

No. 670305 - Strap Wrench

VIBRATION TACHOMETER

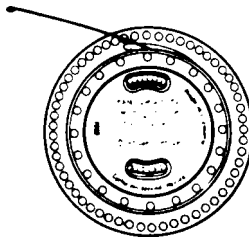

No. 670156 - Vibration Tachometer

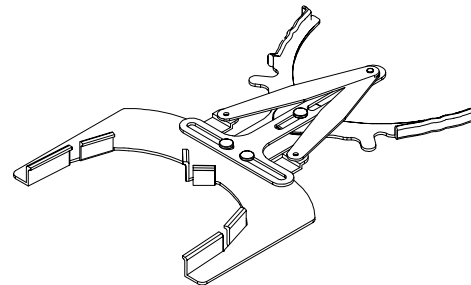

No. 670117 - Ring Expander

AIR GAP GAUGE



***No. 670216** - Air gap gauge .0075 (.191 mm) shim stock for setting air gap.