



SERVICE BULLETIN 125
INFORMATIONAL

ISSUED: AUGUST 1999

SUBJECT: DAMAGED FUEL LINE

MODELS AFFECTED: ALL UNITS EQUIPPED WITH FUEL SHUT-OFF

DATES OF MANUFACTURE AFFECTED: 9121 (May 1) through 9233 (August 21)

We have recently discovered a potentially **HAZARDOUS** situation, which is a rarely occurring small pin hole leak or leaks in the short section of the fuel line as shown below.

Because this is a safety related issue, **REPLACEMENT OF** the short fuel line on the affected products as shown is required.

It is **CRITICAL** to check all product before sale AND to locate any units distributed which are within the above Dates of Manufacture. Units which have been previously updated at the Manufacturing level will have a Yellow paint mark on the short line as shown in the illustration. Unless the unit within the dates of manufacture has a yellow mark as shown, replacement of the short fuel line is required.

To aid in this repair, submission of warranty claims listing multiple Model Specification and Dates of Manufacture will be accepted. A repair time of 15 minutes per unit (out of box) and 30 minutes for units (boxed) should be noted on the claim.

To insure the quantity of units repaired by each dealer is recorded and only the correct parts are used, we have decided to drop ship parts factory to dealer direct.

To obtain the service kit **part number 730632** within the United States please call (262) 377-2700 ask for ext. 1311 or the service bulletin desk ref. #125.

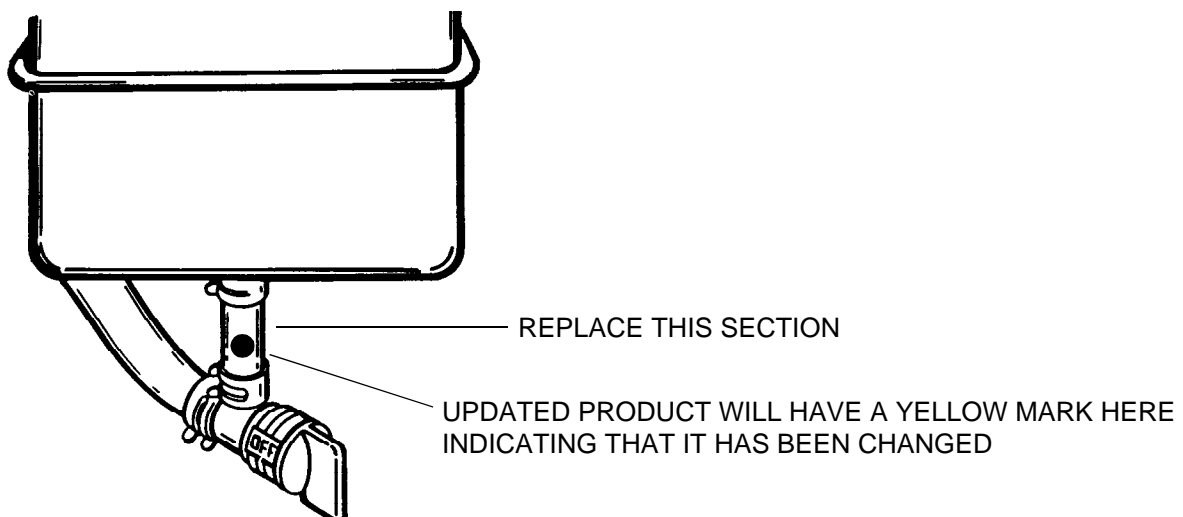



**SERVICE
BULLETIN
125
INFORMATIONAL**

REPAIR UNIT LOCATION OF IDENTIFYING STAMP MARK "0"

Top View

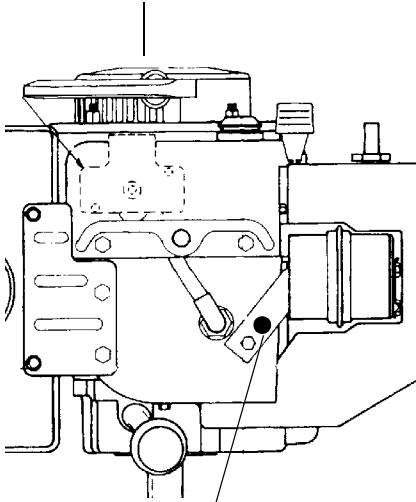

STAMP "0" ON MUFFLER STRAP
HM/HMSK80-110

Side View

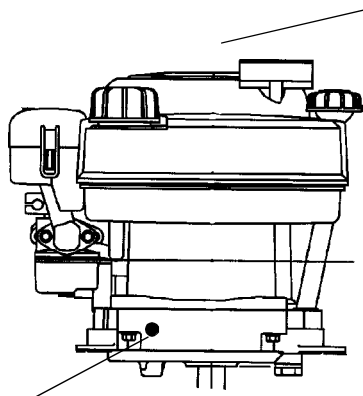

STAMP "0" ON FLANGE
LEV115

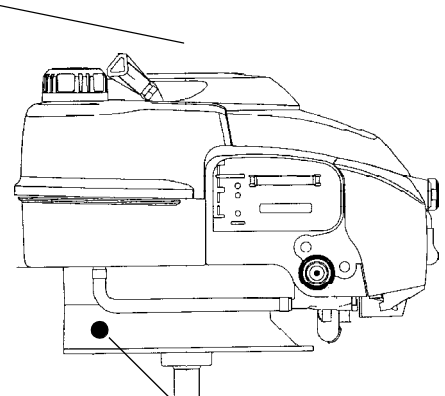

STAMP "0" ON FLANGE
VLV126

Top View

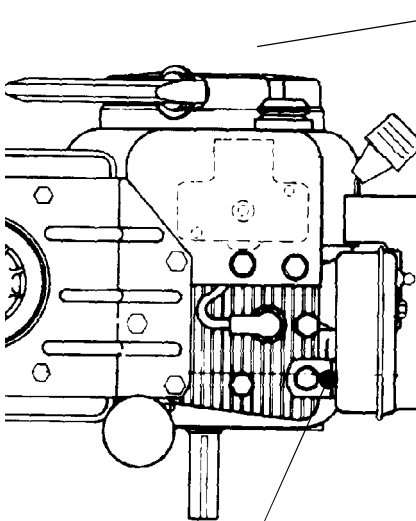

STAMP "0" ON
MUFFLER STRAP

H/HS/HSSK35-70

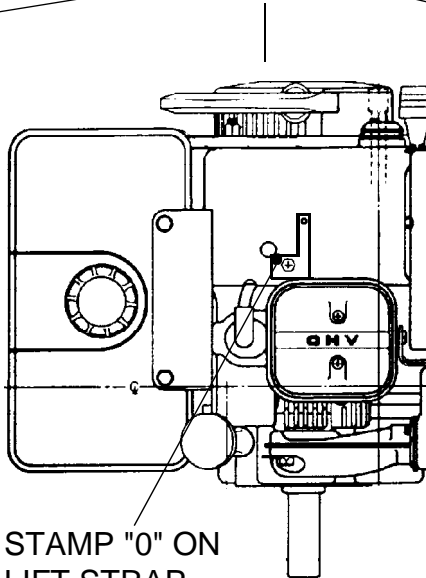

STAMP "0" ON
LIFT STRAP

OHSK80-130

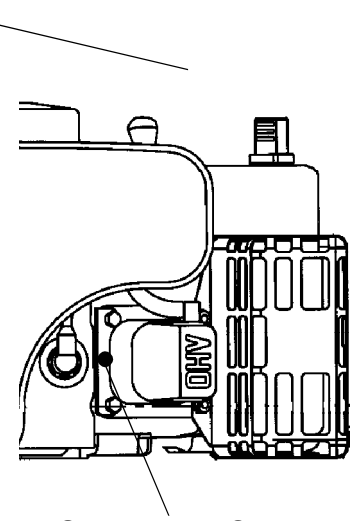

STAMP "0" ON
LIFT STRAP

OHSK50-70

Note: Some updated units will be identified as follows: The "0" will be stamped into the engine mounting flange, underneath the fuel tank, next to the oil drain plug.