

**SERVICE MANUAL FOR POULAN – POULAN/PRO
33cc 34cc 36cc 40cc and 42cc**

**1900-1900LE-1950-1950LE-2050-2050LE-2055LE-2075
2075LE-2150-2150LE-2175-2175LE-2150-2150LE-2375
2375LE WILD THING-2250-2450-2550 POULAN PRO
220-221-221LE-260-260LE**

**SCREW TORQUE SPECIFICATIONS - AV
ONLY**

PART NO.	LOCATION (QTY.)	SIZE	TORQUE IN-LB
STARTER GROUP			
530-015892	FAN HOUSING	M5.28 X 1.81	20-30 IN-LB
530-015920	STARTER PULLEY	M5.25 X 1.81	25-35 IN-LBS
530-016080	ROPE SCREW	M3.63 X 1.34	5-10 IN-LB
IGNITION GROUP			
530-016134	FLYWHEEL NUT	M8 X 1	12-14 FT-LB
530-015814	MODULE	M5.28 X 1.81	25-35 IN-LB
952-030150	SPARK PLUG	M14 X 1.25	15-25 FT-LB
CYLINDER GROUP			
530-016132	CHASSIS/CYLINDER	M6 X 1.0	110-140 IN-LB
530-016132	MUFFLER	M6 X 1.0	90-100 IN-LB
530-015875	ISO SPRING/CYLINDER	M4.85 X 1	40-50 IN-LB
530-016338	MUFFLER (LE)	M6X1.0	90-100 IN-LB
530-016359	BRASS NUT COVER (LE)	10 - 24	25-35 IN-LB
CARBURETOR & AIR BOX GROUP			
530-015810	CARB. ADAPTER	10 - 24	40-50 IN-LB
530-016101	AIR FILTER NUT	M5 X .08	25-35 IN-LB
530-015780	AIR PURGE	6 - 19	10-15 IN-LB
CHASSIS, FUEL TANK & HANDLE GROUP			
530-016153	CYLINDER SHIELD	M4.8 X 1.6	20-30 IN-LB
530-015906	FRONT SPRING/CHASSIS	M5.28 X 1.81	25-35 IN-LB
530-016018	FRONT SPRING/BAR	10 - 24	40-50 IN-LB
530-016015	SPRING ASSY/CHASSIS	M5.25 X 1.81	30-40 IN-LB
530-015814	FRONT/REAR HANDLE	M5.28 X 1.81	20-30 IN-LB
530-015814	REAR BOTTOM SPRING/HANDLE	M5.28X1.81	25-35 IN-LB
530-016179	REAR TOP SPRING/HANDLE	10X14X1.06	20-30 IN-LB
530-015886	REAR SPRING HANDLE/COVER	M5.28 X 1.81	30-40 IN-LB
530-015906	REAR HANDLE COVER	M5.28 X 1.81	30-40 IN-LB
530-015906	REAR SPRING CHASSIS	M5.28-1.81	30-40 IN-LB
530-015814	CHAIN CATCHER	M5.28 X 1.81	30-40 IN-LB
CLUTCH GROUP			
530-014949	CLUTCH ASSEMBLY	M6 X 1.0 L.H.	10-15 FT-LB
530-015917	BAR MOUNTING NUT	M8 X 1.25	10-20 FT-LB
OILER GROUP			
530-016064	OIL PUMP	M3.63 X 1.34	5-10 IN-LB

NON AV TORQUE SPEC.

PART NO.	LOCATION	SIZE	TORQUE IN-LBS
NON AV TORQUE SPEC.			
STARTER GROUP			
530-015892	FAN HOUSING	M5.28 X 1.81	20-30 IN-LB
530-015920	STARTER PULLEY	M5.28 X 1.81	25-35 IN-LB
530-016080	ROPE SCREW	M3.63 X 1.34	5-10 IN-LB
IGNITION GROUP			
530-016134	FLYWHEEL NUT	M8 X 1	12-14 FT-LB
530-015775	SWITCH SPRING	8-16	25-35 IN-LB
530-015814	MODULE	M5.28 X 1.81	25-35 IN-LB
530-030153	SPARK PLUG	M14 X 1.25	15-25 FT-LB
CYLINDER GROUP			
530-016132	CHASSIS/CYLINDER	M6 X 1.0	110-140 IN-LB
530-016132	MUFFLER	M6 X 1.0	90-100 IN-LB
530-016338	MUFFLER (LE)	M6 X 1.0	90-100 IN-LB
530-016359	BRASS NUT COVER (LE)	10-24	25-35 IN-LB
CARB.& AIR BOX			
530-015810	CARB. ADAPTER	10-24	40-50 IN-LB
530-016101	AIR FILTER NUT	M5 X .08	25-35 IN-LB
530-015780	AIR PURGE	6-19	10-15 IN-LB
CHASSIS,TANK & HANDLE			
530-016153	CYLINDER SHIELD	M4.8 X 1.6	20-30 IN-LB
530-015814	(TOP) H-BAR/CHASSIS	M5.26 X 1.81	22-32 IN-LB
530-015940	(BOTTOM) H-BAR/CHASSIS	10-14	22-32 IN-LB
530-015814	CHAIN CATCHER	M5.28 X 1.81	30-40 IN-LB
CLUTCH GROUP			
530-014949	CLUTCH ASSEMBLY	M6 X 1.0 L.H.	10-15 FT-LB
530-015917	BAR MOUNTING NUT		10-15 FT-LB
OILER GROUP			
530-016064	OIL PUMP (2)	M3.63 X 1.34	5-10 IN-LB

NOTE: ALL TORQUES WILL BE IN IN-LBS UNLESS SPECIFIED IN (FT-LB)

SUMMARY OF PERFORMANCE SPECIFICATION

COMPRESSION (COLD)	BARE	CHROME
36cc/40cc BARE/CHROME	130-150	145-165

42cc LE AV/NON AV	125-145	125-145
-------------------	---------	---------

CRANKSHAFT ENDPLAY	0.00-0.85 MM
--------------------	--------------

IGNITION TIMING	27-32 BTDC
-----------------	------------

COIL AIR GAP	.020/.038
--------------	-----------

LEAK CHECK CRANK CASE TO 5 PSI. DROP .05 PSI IN 1.5 SECONDS

SPARK PLUG GAP	.025
----------------	------

1. CRANKSHAFT, PISTON, AND ROD ASSEMBLY

- A. CARE MUST BE TAKEN TO PROTECT SURFACE OF PISTON FROM NICKS AND SCRAPES.
- B. PISTON PIN ASSEMBLY FIXTURE MUST BE KEPT CLEAN TO AVOID DAMAGE TO THE PISTON.
- C. PISTON PINS MUST BE CLEAN AND FREE OF NICKS AND SCRATCHES. (DO NOT THROW OR SUBJECT TO SEVERE JOLTS DURING HANDLING.)
- D. CONNECTING ROD SHOULD REVOLVE FREELY AROUND CRANK PIN.
- E. PLACE A DROP OF POULAN 2-CYCLE ENGINE OIL ON CRANK PIN BEARING AND ON PISTON PIN BEARING AS SHOWN.
IMPORTANT NOTE: USE SEAL PROTECTOR WHEN INSTALLING BEARING AND SEAL ASSEMBLY ONTO SHAFT.
- F. INSTALL BEARING AND SEAL ASSEMBLY ONTO CRANKSHAFT.
NOTE: BEFORE INSTALLING SEALS, APPLY POULAN 2-CYCLE ENGINE OIL AS SHOWN IN FIGURE B.
- G. INSTALL OILER WORM GEAR ONTO CRANKSHAFT WITH ASSEMBLY TOOL UNTIL COIL FALLS IN GROOVE. MAINTAIN COIL PITCH 2.59 - 2.92MM. (FIGURE C)

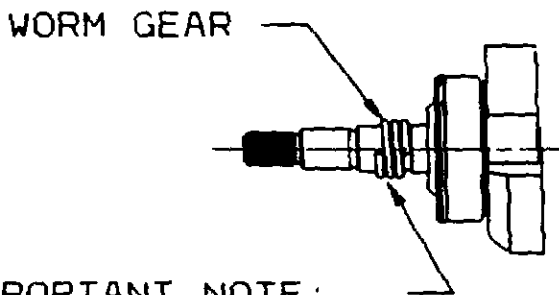

IMPORTANT NOTE:
COILS MUST NOT
TOUCH EACH OTHER.

(FIGURE C)

**NOTE; WORM GEAR INSTALLATION IS CRITICAL. USE
TOOL PN 530031166 FOR CORRECT PITCH SPACII**

2. CRANKSHAFT, PISTON, AND ROD ASSEMBLY - CONTINUED

- I. INSTALL PISTON PIN INTO PISTON BOSS, THROUGH PIN BEARING AND ROD, AND INTO OPPOSITE PISTON BOSS. (FIGURE D)
- J. INSTALL PISTON PIN RETAINERS (DYED RED). RETAINERS MUST BE SEATED COMPLETELY IN GROOVE AND NOT BENT.
- K. INSTALL PISTON RING IN PISTON RING GROOVE USING ASSEMBLY TOOL. ENSURE RING IS ORIENTED PROPERLY RELATIVE TO RING PEG (SEE FIG. "D"). DO NOT OVER STRESS RING. (CAREFULLY INSTALL RING BY HAND IF TOOL IS NOT AVAILABLE.)

IMPORTANT NOTE: BE CAREFUL WHEN INSTALLING PISTON AND ROD ASSEMBLY INTO CYLINDER TO PREVENT BREAKING THE PISTON RING. INSTALLATION ON PAGE 11.

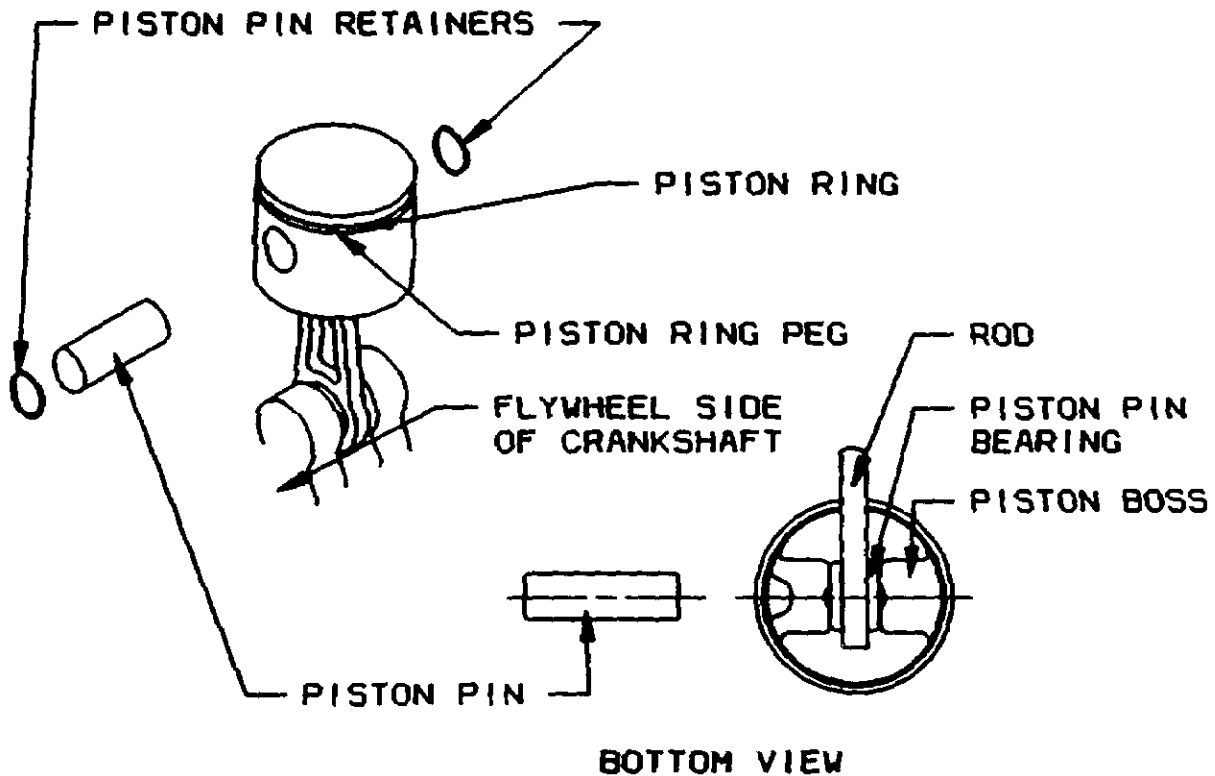

FIGURE D

3. CYLINDER ASSEMBLY

- A. ASSEMBLE CARB SEAL (#3 IN FIGURE E) ON CARB ADAPTOR (#1 IN FIGURE E) MAKING SURE TO ALIGN THE ALIGNMENT TAB ON CARB ADAPTOR AND ALIGNMENT HOLE ON CARB SEAL. ENSURE CARB SEAL IS FULLY SEATED ON CARB ADAPTOR.
- B. POSITION (2) CARB MOUNTING SCREWS (#1A IN FIGURE E) INTO THE CARB ADAPTOR. #1 IN FIGURE E.
- C. PLACE CARB GASKET (#1B IN FIGURE E) OVER LOCATOR PINS ON CARB ADAPTOR.
- D. INSTALL CARB ADAPTOR ASSEMBLY ONTO CYLINDER. SECURE WITH TWO (2) SCREWS (#2 IN FIGURE E). TORQUE TO SPECIFICATION.
- E. CSI-AV ONLY: INSTALL TOP REAR ISOLATOR SPRING ASSEMBLY ONTO CYLINDER. SECURE WITH ONE (1) SCREW, TORQUE TO SPECIFICATION.

FIGURE E

4. **CYLINDER ASSEMBLY - CONTINUED**

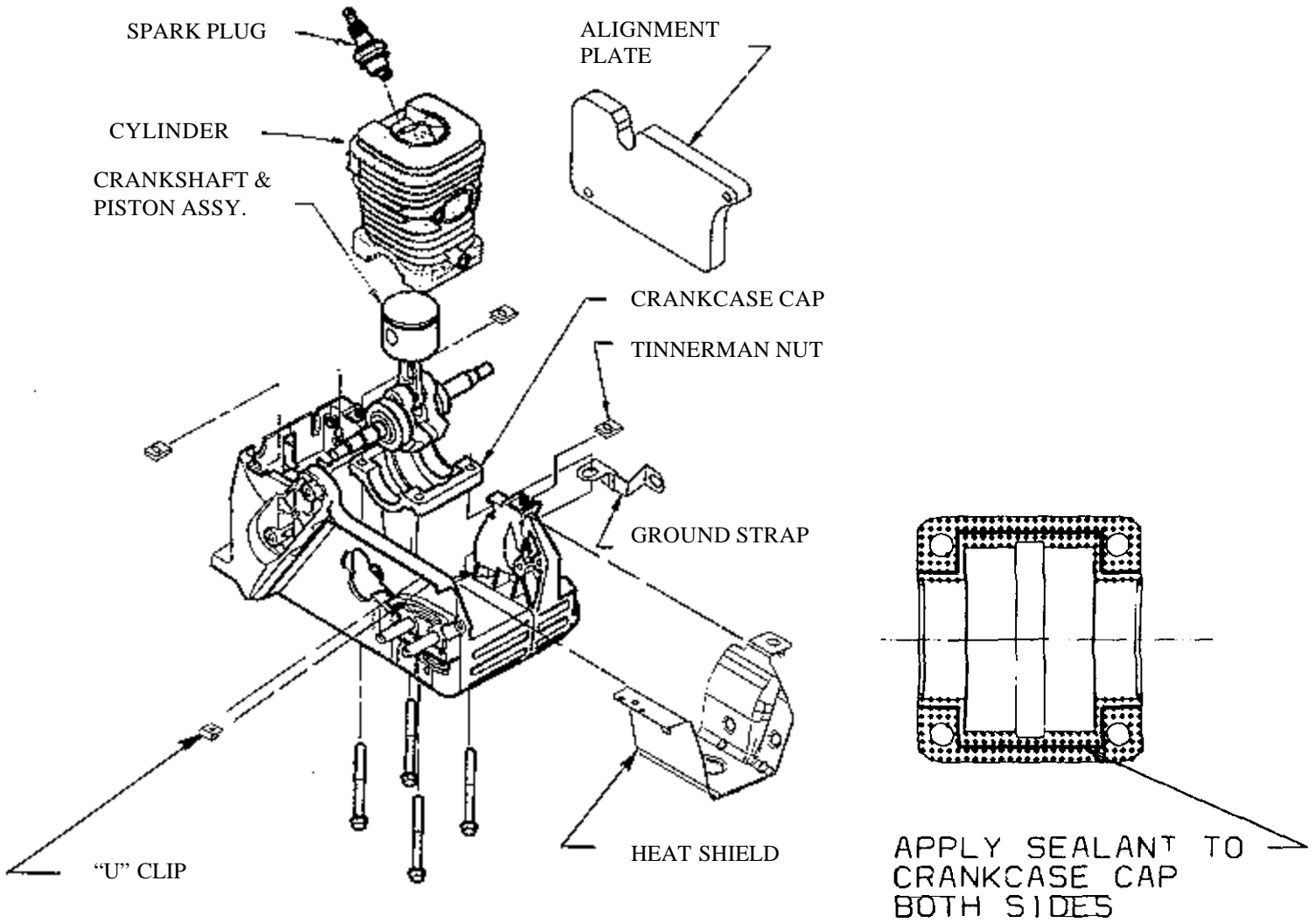

FIGURE F

FIGURE G

- F. OIL RING AND INSTALL CRANKSHAFT, PISTON, AND ROD ASSEMBLY IN CYLINDER (FIGURE F).
- G. APPLY SMALL CONSISTENT BEAD OF SEALANT. BEAD MUST NOT BE "PUDDLED" OR ANY SKIPS. NO PART OF SEALING BEAD IS ALLOWED IN BEARING POCKETS. DO NOT LET SEALANT DRY OVER 5 MINUTES. (PRIOR TO ASSY).
-
- H. POSITION GROUND STRAP TO CHASSIS (FIGURE F).
- I. INSTALL THREE (3) TINNERMAN NUTS INTO CHASSIS POCKETS.
- J. INSTALL HEATSHIELD AS SHOWN. "U" CLIP IS USED TO SECURE HEAT SHIELD IN POSITION (LOW EMISSION ENGINES ONLY) (FIGURE F)..
- K. PLACE CRANKSHAFT ALIGNMENT PLATE INTO LOCATING HOLES ON CHASSIS. PLACE CHASSIS ON CYLINDER, ALIGNING CRANKSHAFT WITH PLATE.
- L. SECURE CYL. TO CHASSIS. TORQUE TO 100 IN/LB MIN.

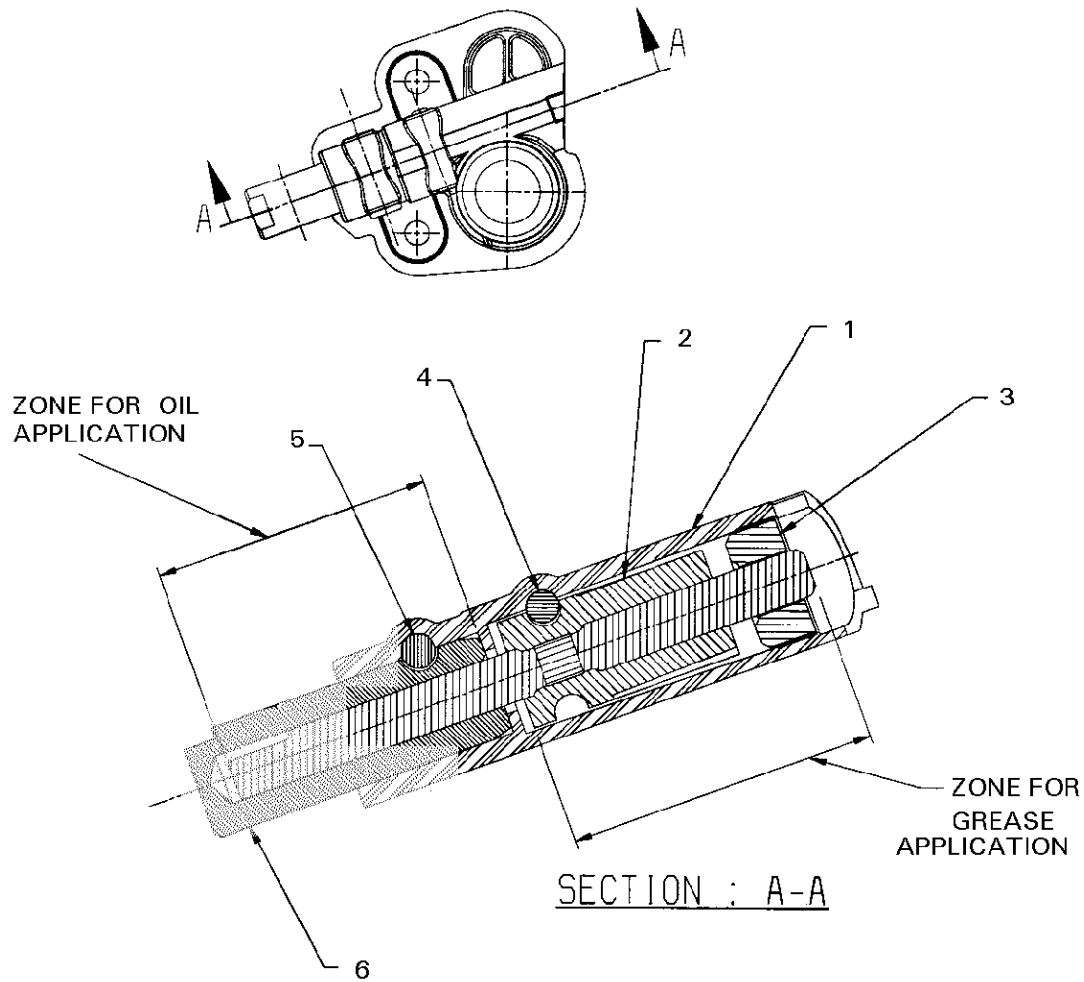
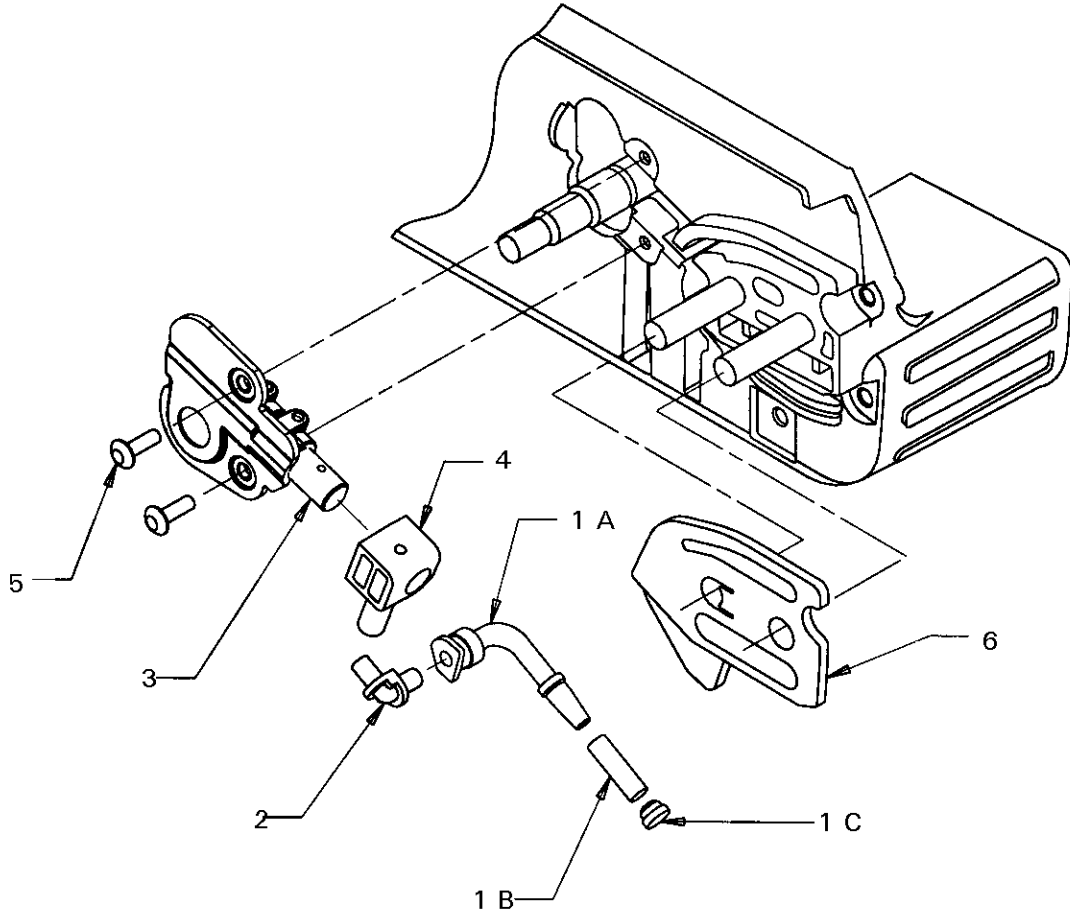

FIGURE H 1

ITEM	DESCRIPTION	QUANTITY
1	BODY, OIL PUMP	1
2	ASS'Y , GEAR & PLUNGER	1
3	BUSHING, OIL PUMP	1
4	PIN, CAM	1
5	RIVET	1
6	BARREL, OIL PUMP	1

7. OILER ASSEMBLY



ITEM	DESCRIPTION	FIGURE (G) QUANTITY
1A	OILER PICK-UP	1
1B	OILER FILTER (SPRING)	1
1C	OIL FILTER PLUG	1
2	ELBOW FITTING	1
3	OIL PUMP ASSEMBLY	1
4	SEAL BLOCK	1
5	OILER SCREW	1
6	BAR PLATE	1

8. OILER ASSEMBLY - CONTINUED

- A. ASSEMBLE PLUG INTO PICKUP FILTER.
- B. ASSEMBLE FILTER ONTO PICKUP.
- C. CAREFULLY POSITION OILER PICKUP INTO CHASSIS.

IMPORTANT NOTE: FAILURE TO INSTALL CORRECTLY WILL RESULT IN A NON-FUNCTIONING OILER. SEE FIGURE (G) FOR CORRECT POSITIONING OF PICKUP.

- D. INSTALL SEAL BLOCK ONTO PUMP BARREL.

NOTE: HOLE IN TOP OF BLOCK WILL ALIGN WITH HOLE IN BARREL.
- E. PLACE ELBOW FITTING ON END OF SEAL BLOCK.
- F. INSTALL OIL PUMP ASSEMBLY WITH SEAL BLOCK AND ELBOW ONTO CHASSIS.
- G. CONNECT ELBOW FITTING TO PICKUP.
- H. USING TWO (2) SCREWS, TORQUE OIL PUMP ASSEMBLY TO SPECIFICATION. TORQUE TOP SCREW FIRST.
- I. INSTALL BAR PLATE.

9. MUFFLER ASSEMBLY

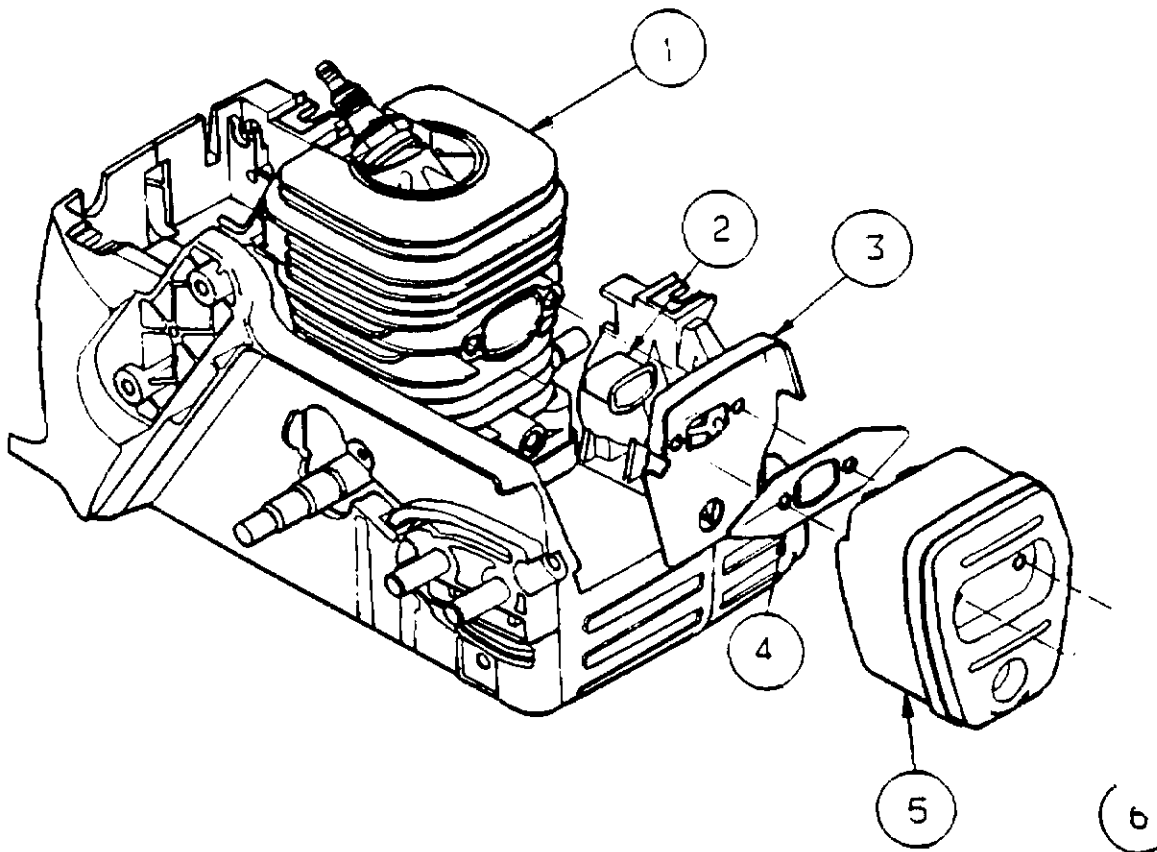

ITEM	DESCRIPTION	QUANTITY
1	CYLINDER	1
2	HEAT INSULATOR	1
3	BACKPLATE	1
4	MUFFLER GASKET	1
5	MUFFLER ASSEMBLY	1
6	MUFFLER BOLT	2
7	BACKPLATE(LE)	1
8	DEFLECTOR(LE)	1
9	MUFFLER ASSY.(LE)	1
10	COVER-BOLT (LE)	1
11	NUT-BRASS(LE)	1
12	MUFFLER BOLT(LE)	2

10. MUFFLER ASSEMBLY

- A. INSTALL HEAT INSULATOR INTO CYLINDER.

NOTE: ITEMS #3, #4, #5, AND #6 MAY BE RECEIVED ASSEMBLED. IF SO, TORQUE TO SPECIFICATION.

- B. INSTALL MUFFLER PLATE.

NOTE: THE SIDE OF PLATE STAMPED MUFFLER SIDE SHOULD BE PLACED TOWARD THE MUFFLER BODY, AND AWAY FROM THE CYLINDER.

- C. PLACE MUFFLER GASKET BETWEEN PLATE AND MUFFLER BODY.

- D. INSTALL THE TWO (2) MOUNTING SCREWS. TORQUE TO SPECIFICATION.

IMPORTANT NOTE: MUFFLER HALVES MUST BE SEATED PROPERLY TO PREVENT LEAKS.

9. FLYWHEEL ASSEMBLY

- D. INSTALL FLYWHEEL, USING CARE TO ALIGN "CAST IN KEY" ON FLYWHEEL WITH THE KEYWAY ON CRANKSHAFT. THE CAST RECESS ON THE FLYWHEEL INDICATES THE POSITION OF THE "CAST IN KEY" (FIGURE H)

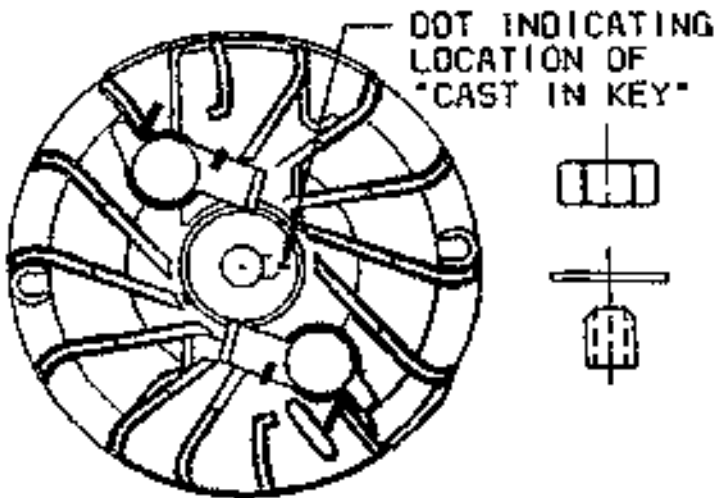

FIGURE H

- E. INSTALL FLAT WASHER, AND NUT. TORQUE TO SPECIFICATION (FIGURE L).

NOTE: IMPORTANT TO CLEAN CRANKSHAFT TAPER WITH A ALCOHOL DAMPENED CLOTH TO REMOVE GREASE. FAILURE TO DO THIS COULD CAUSE THE FLYWHEEL KEY TO SHEAR.

11. IGNITION ASSEMBLY - NON-AV AND AV

- A. PRESS FLAG TERMINAL ONTO THE SPADE TERMINAL ON MODULE.
- B. POSITION UPPER MODULE SCREW THROUGH RING TERMINAL ON BLACK WIRE. POSITION TERMINAL AGAINST EPOXY.
- C. INSTALL IGNITION MODULE WITH TWO (2) SCREWS. SET AIR GAP TO SPECIFICATION (.2MM - .38MM. TORQUE SCREWS TO SPECIFICATION .
- D. ROUTE WIRES AS SHOWN.

IMPORTANT NOTE: DO NOT POSITION WIRE WHERE CYLINDER SHIELD SCREW WILL BE.

- E. ROUTE WIRES BETWEEN CYLINDER FINS. POSITION SPARK PLUG WIRE BY FINS, AND INSTALL CLIP (FIGURE I). POSITION SPARK PLUG BOOT TOWARD FLYWHEEL AT 7 -8 O'CLOCK TOWARD FAN HOUSING.
- F. ROUTE WIRES BETWEEN CARBURETOR ADAPTOR AND CHASSIS INTO AIR BOX.

KILL SWITCH WIRE SHOULD BE
ASSEMBLED BEHIND IGNITION WIRE.



12. IGNITION ASSEMBLY - NON-AV ONLY - CONTINUED

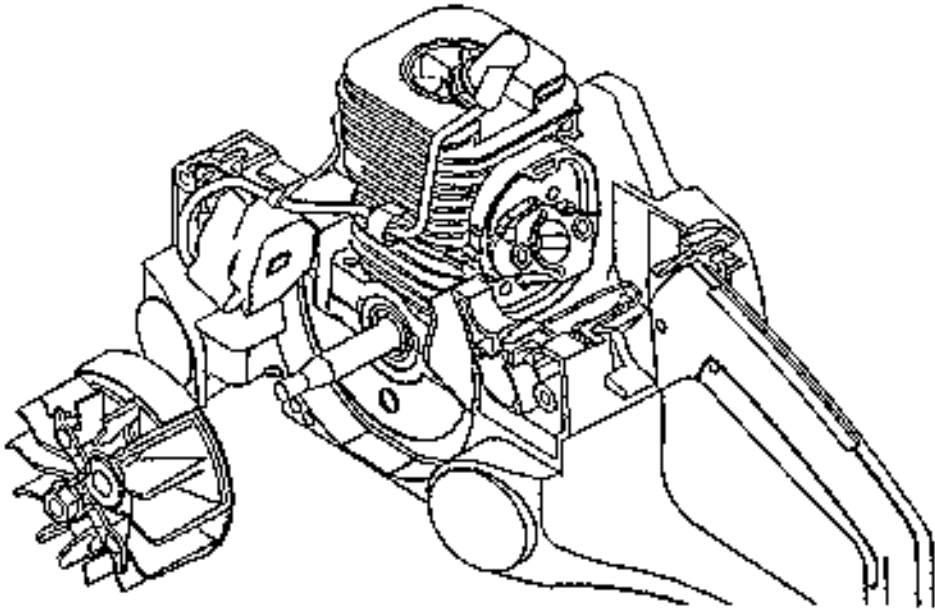

FIGURE I

- G. PLACE SCREW THROUGH RING TERMINAL ON BLACK WIRE, THEN THROUGH SWITCH SPRING. TORQUE TO SPECIFICATION.

NOTE: RING TERMINAL MUST BE POSITIONED AGAINST BOSS DURING INSTALLATION (FIGURE J).

- H. INSTALL PLUG TERMINAL INTO KILL SWITCH.

NOTE: THIS MAY BE DONE IN ADVANCE (FIGURE J).

- I. MOVING THE SPRING BACK, SNAP THE KILL SWITCH INTO POSITION.

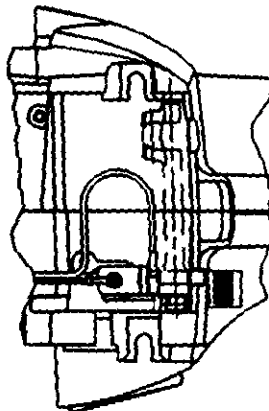

FIGURE J

13. IGNITION ASSEMBLY - AV ONLY - CONTINUED

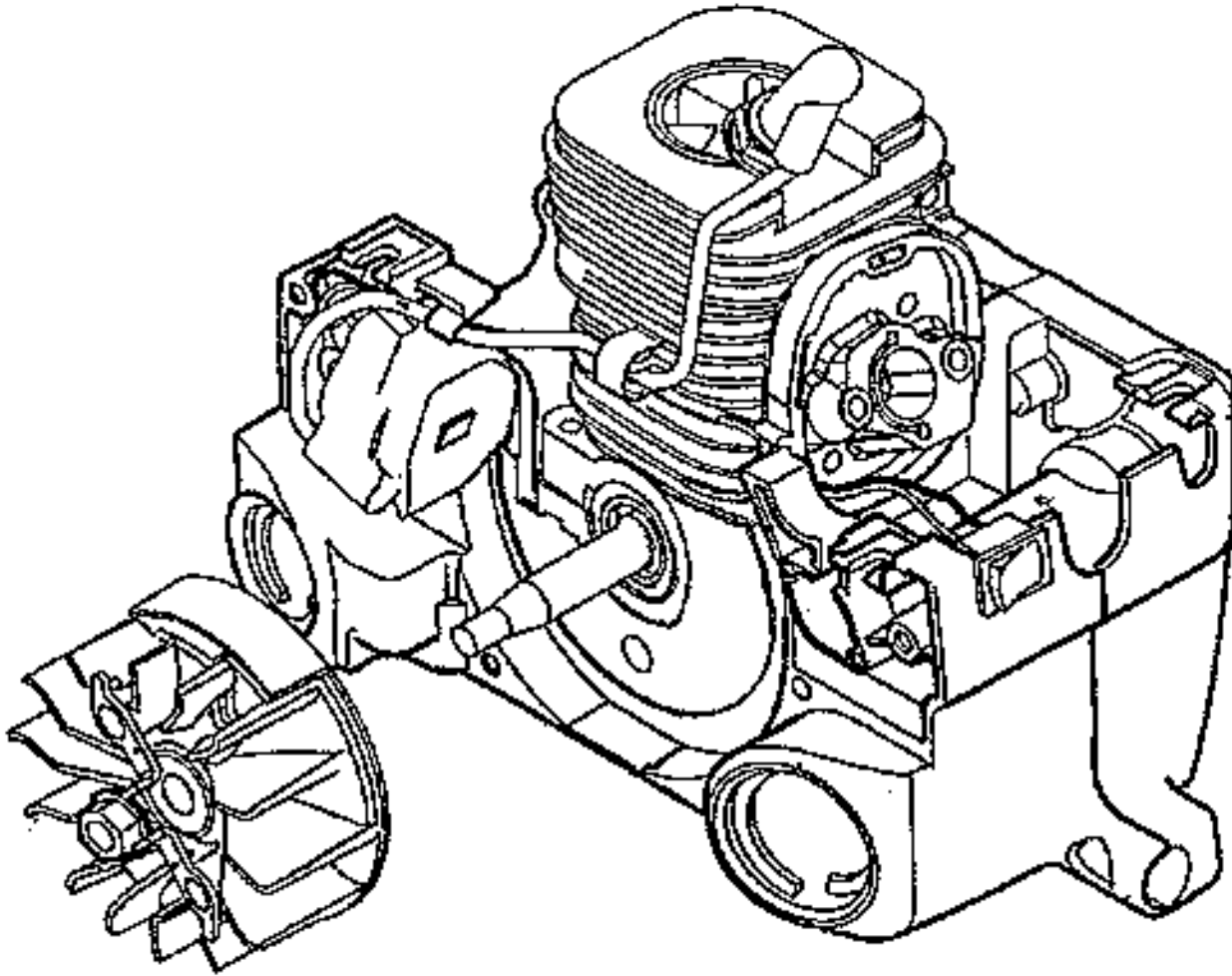

FIGURE K

- J. PRESS TWO (2) WIRE TERMINALS ONTO TWO (2) SPADE TERMINALS ON BACK OF THE IGNITION SWITCH.

NOTE: WIRES MAY BE PRE-ASSEMBLED ONTO SWITCH.

- K. SNAP IGNITION SWITCH INTO OPENING IN REAR OF THE LEFT CHASSIS (FIGURE K).

IMPORTANT NOTE: ORIENT SWITCH WHERE THE "I" IS CLOSEST TO THE FAN HOUSING SIDE OF CHASSIS. ALSO, TERMINALS ARE CLOSEST TO THE FAN HOUSING SIDE.

14. FUEL LINE AND PURGE BULB ROUTINGS

IMPORTANT NOTE: MAXIMUM GAP BETWEEN END OF LINE, AND FITTING BASE TO BE 1.3MM (FIGURE L).

- A. CONNECT RETURN LINE (LARGER OF TWO LINES) FROM RIGHT HALF OF CHASSIS TO LARGE NIPPLE ON PURGE BULB.
- B. CONNECT PURGE LINE TO SMALL NIPPLE ON BULB. LAY INTO POSITION.
- C. NON-AV ONLY CONNECT PURGE LINE TO BRASS FITTING ON CARBURETOR.
NON-AV ONLY CONNECT FUEL LINE FROM LEFT HALF OF CHASSIS TO BLACK PLASTIC FITTING ON CARBURETOR.
- D. AV ONLY CONNECT PURGE LINE TO BRASS FITTING ON ADJUSTMENT (LEFT) SIDE OF CARBURETOR.
AV ONLY CONNECT FUEL LINE FROM LEFT HALF OF CHASSIS TO BRASS FITTING ON CHOKE LEVER (RIGHT) SIDE OF CARBURETOR.
- E. POSITION ALL LINES UNDER TAB ON CARB ADAPTOR (IF AVAILABLE).
- F. WHEN CHANGING PURGE BULB, CUT 1/16 FROM END OF FUEL LINE, RE INSTALL LINE. THIS WILL INSURE TIGHT FIT OF LINE ON TO THE BARB OF CARB.

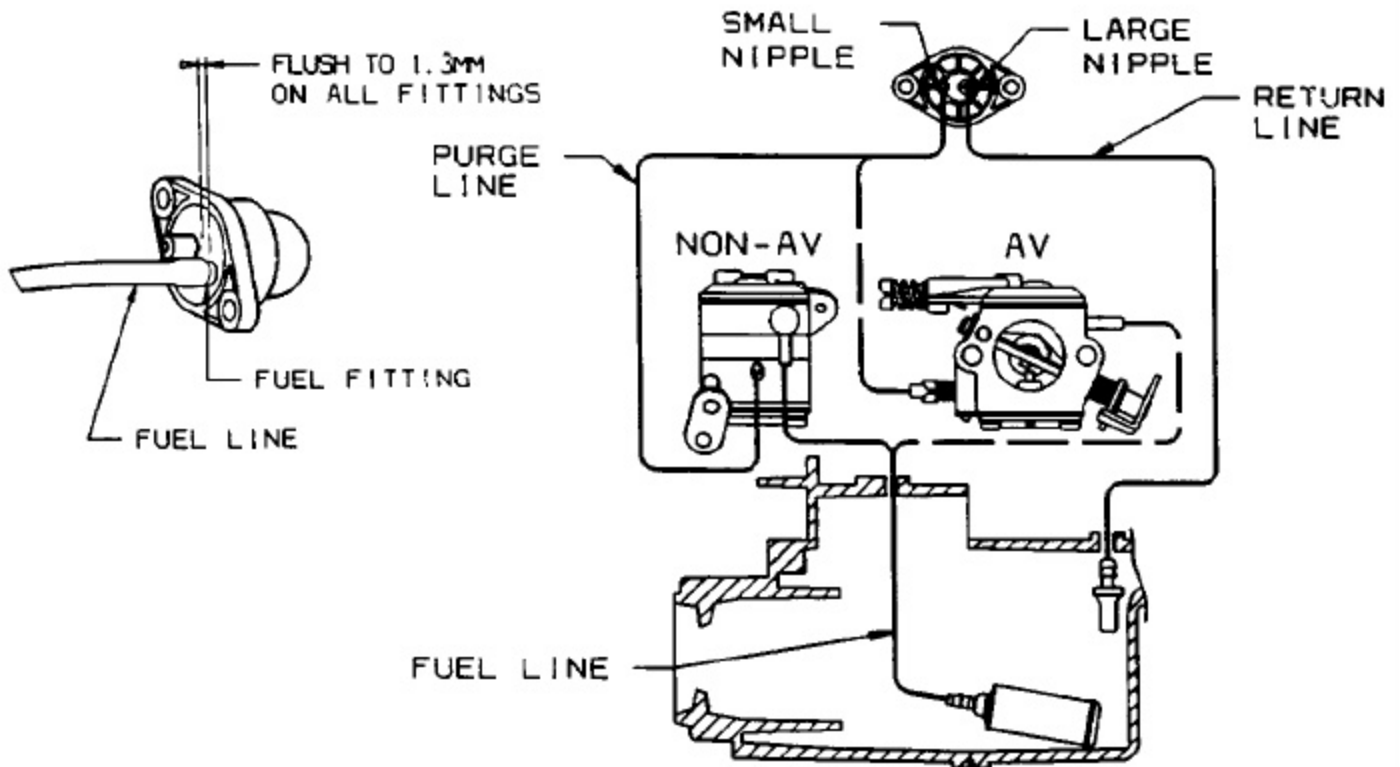
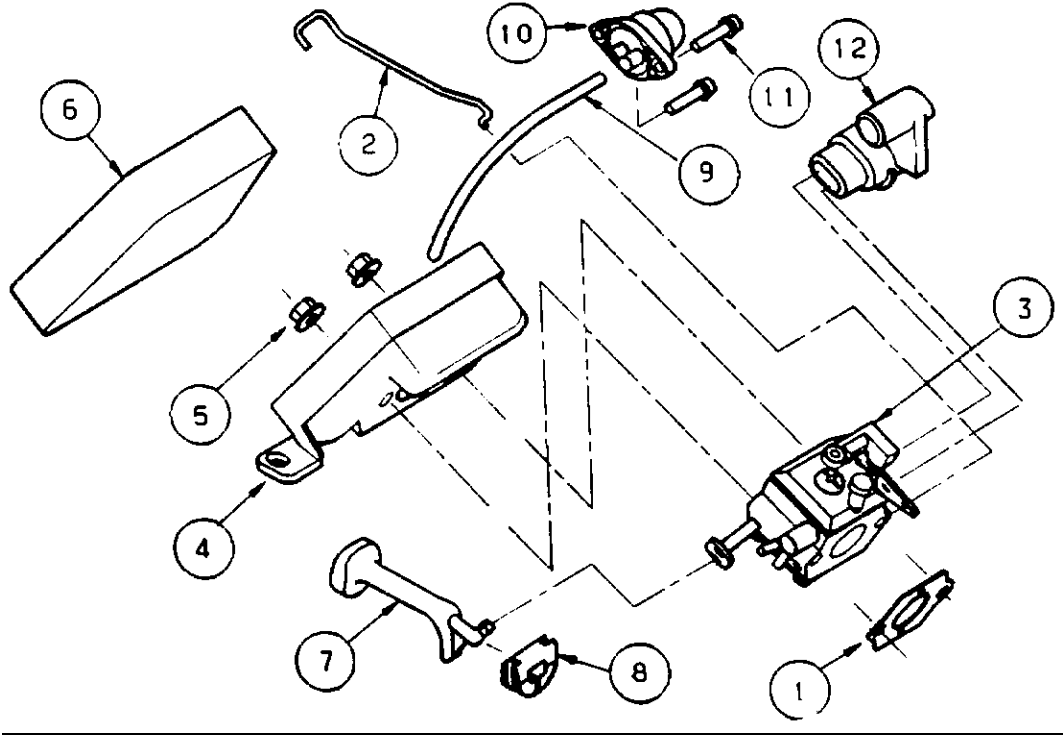

FIGURE L

15. AIR BOX ASSEMBLY - NON-AV ONLY



ITEM	DESCRIPTION
1	CARBURETOR GASKET
2	THROTTLE WIRE
3	CARBURETOR (WT-324)
4	AIR BOX
5	NUTS
6	AIR FILTER (FOAM)
7	CHOKE LEVER
8	CHOKE GROMMET
9	PURGE LINE
10	PURGE BULB
11	SCREWS-PURGE
12	CARBURETOR GROMMET

16. AIR BOX ASSEMBLY - NON-AV ONLY - CONTINUED

- A. FIT CARBURETOR GASKET OVER SCREWS THROUGH CARBURETOR ADAPTOR.
- B. INSTALL THROTTLE WIRE INTO CARBURETOR THROTTLE PLATE, THEN TO TRIGGER (FIGURE M).
- C. DEPRESS TRIGGER TO POSITION CARBURETOR OVER STUDS.
- D. INSTALL CHOKE ROD GROMMET TO CHOKE ROD.
- E. ATTACH CHOKE ROD TO CARBURETOR (FIGURE M), THEN LAY GROMMET THROUGH OPENING IN CHASSIS.
- F. TORQUE PURGE BULB TO SPECIFICATION.
- G. INSTALL CARBURETOR GROMMET.

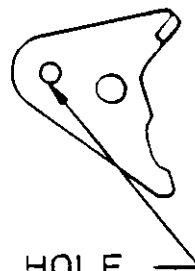
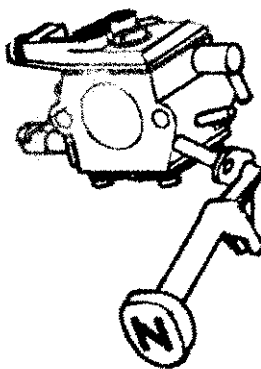

THROTTLE WIRE HOLE

FIGURE M

- H. POSITION AIRBOX. START NUTS BY HAND. TORQUE TO SPECIFICATION.
- I. OIL AIR FILTER USING 2 CYCLE OIL. INSTALL AIR FILTER.

IMPORTANT NOTE: ALL EXCESS OIL MUST BE SQUEEZED FROM THE FILTER PRIOR TO INSTALLATION INTO THE AIR BOX.

IMPORTANT NOTE: VERIFY THROTTLE LOCK, AND TRIGGER FUNCTION. IT MUST WORK FREELY, AND NOT STICK WHEN RELEASED.

17. AIR BOX ASSEMBLY - AV ONLY -

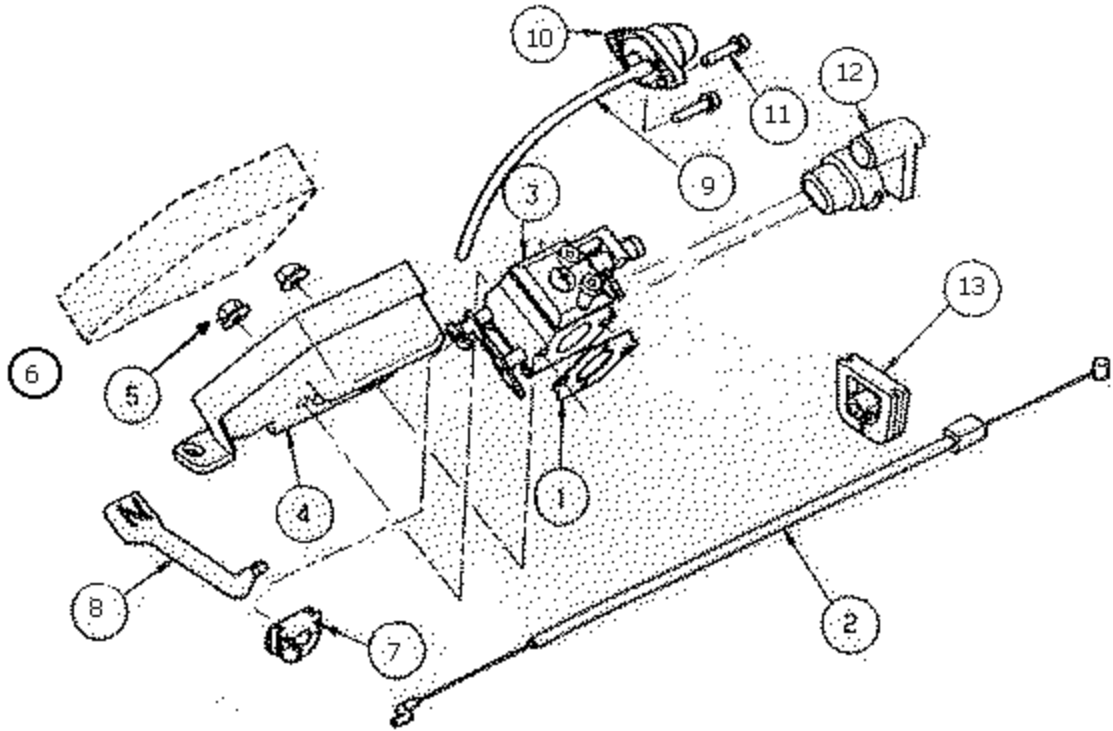

ITEM	DESCRIPTION
1	CARBURETOR GASKET
2	THROTTLE CABLE
3	CARBURETOR
4	AIR BOX
5	NUTS
6	AIR FILTER (FOAM)
7	CHOKE GROMMET
8	CHOKE LEVER
9	PURGE LINE
10	PURGE BULB
11	SCREWS -PURGE
12	CARBURETOR GROMMET
13	THROTTLE CABLE GROMMET

18. AIR BOX ASSEMBLY - AV ONLY - CONTINUED

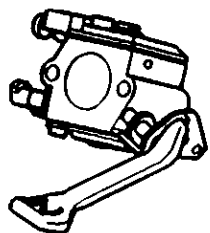

FIGURE N

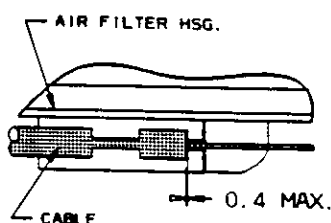

FIGURE O

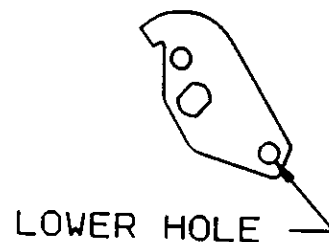
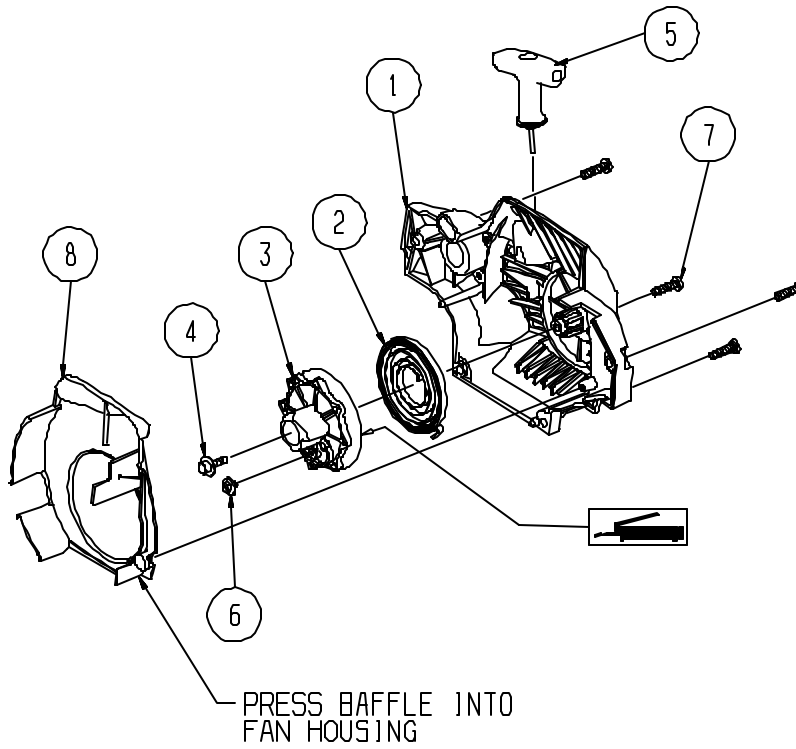

FIGURE P

- A. INSTALL CARBURETOR GASKET OVER SCREWS THROUGH CARBURETOR ADAPTOR.
- B. INSTALL CHOKE ROD GROMMET, AND ATTACH CHOKE ROD TO CARBURETOR (FIGURE N). (CHOKE GROMMET CAN ONLY BE INSTALLED ONE WAY.)
- C. INSTALL CARBURETOR OVER SCREWS, POSITIONING CHOKE ROD GROMMET IN SLOT IN RIGHT CHASSIS.
- D. INSTALL CARBURETOR GROMMET.
- E. INSTALL THROTTLE CABLE ON AIR BOX BY PUSHING CONDUIT END INTO POCKET ON BOTTOM OF THE AIR BOX LOOPING BEHIND AIR BOX.(FIGURE O)
- F. INSTALL "Z" FITTING OF THROTTLE CABLE IN LOWER HOLE OF CARBURETOR THROTTLE LEVER (FIGURE P).
- G. POSITION AIR BOX OVER SCREWS, START NUTS BY HAND. TORQUE TO SPECIFICATION.

NOTE: ENSURE THAT THROTTLE CABLE LOOP IS ROUTED UNDER THE CARBURETOR, AND OVER THE SWITCH WIRES, AND NOT CLAMPED BEHIND THE CARBURETOR.
- H. INSTALL FOAM AIR FILTER.
- I. INSTALL THROTTLE CABLE GROMMET ONTO THROTTLE CABLE, AND PLACE GROMMET INTO SLOT IN REAR OF CHASSIS ASSEMBLY.
- J. TORQUE PURGE BULB TO SPECIFICATION.

19. FAN HOUSING ASSEMBLY AV ONLY . BAFFLE IS NOT USED ON MOST UNIT



ITEM	DESCRIPTION
1	FAN HOUSING
2	RECOIL SPRING
3	STARTER PULLEY
4	SCREW - PULLEY
5	ROPE & HANDLE ASSEMBLY
6	SCREW - ROPE ANCHOR
7	FAN HOUSING SCREWS
8	BAFFLE

20. FAN HOUSING ASSEMBLY AV & NON AV

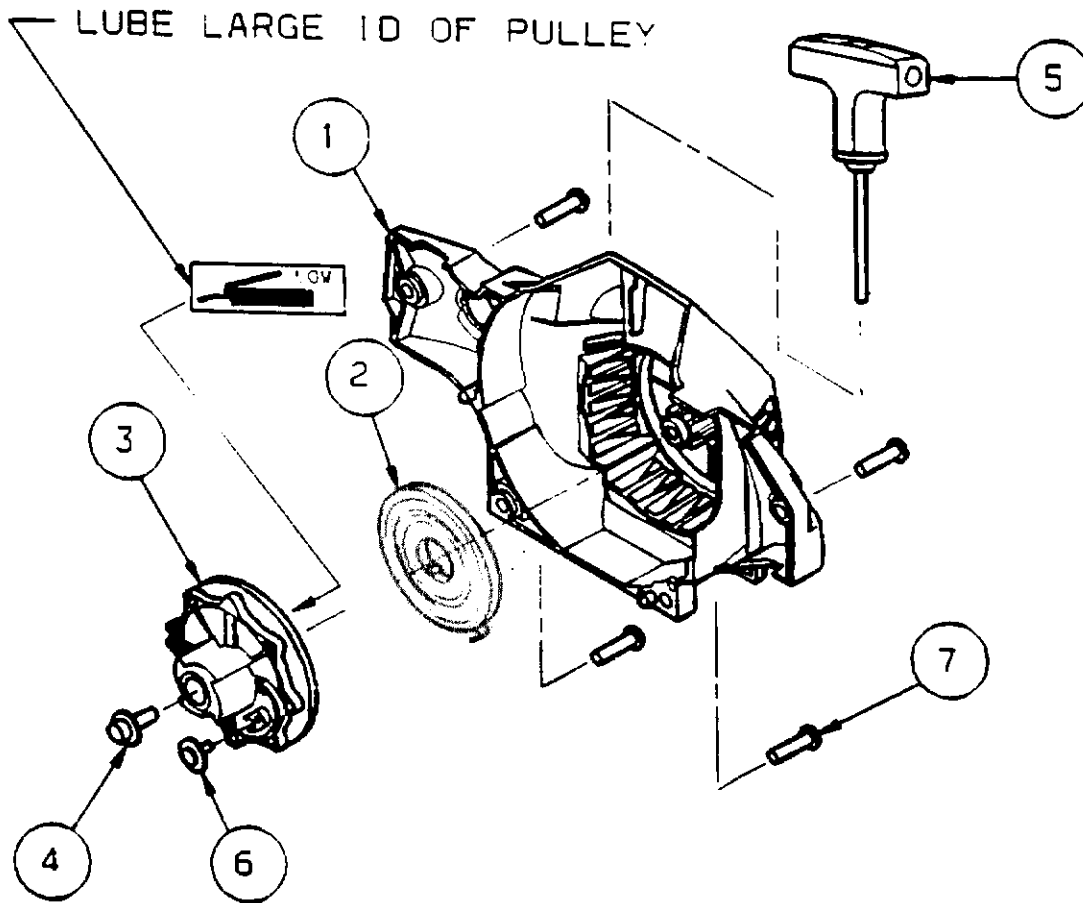

NO.	DESCRIPTION	QUANTITY
1	FAN HOUSING	1
2	RECOIL SPRING	1
3	STARTER PULLEY	1
4	SCREW-PULLEY	1
5	ROPE & HANDLE ASS'Y	1
6	SCREW-ROPE ANCHOR	1
7	SCREW-FAN HOUSING	4

21. RECOIL SPRING ASSEMBLY

- A. PLACE RECOIL SPRING INTO FAN HOUSING, MAKING SURE THE HOOK IS POSITIONED AS SHOWN (FIGURE Q).

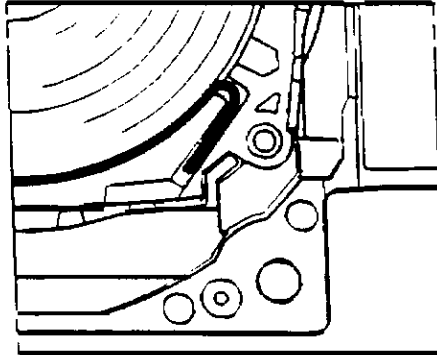

FIGURE Q

- B. WIND UP PULLEY UNTIL IT STOPS, THEN UNWIND 1 TO 2 TURNS, AND ALIGN ROPE HOLE WITH FAN HOUSING EYELET.
- C. FEED ROPE THROUGH FAN HOUSING STARTER ROPE EYELET AND INTO PULLEY HOLE. LOOP ROPE COUNTERCLOCKWISE AROUND RATCHET AND TUCK LOOSE END BACK UNDER ROPE. POSITION END OF ROPE BETWEEN SCREW BOSS AND OUTER RETAINING RING.

IMPORTANT NOTE: END OF ROPE SHOULD BE FLUSH TO 6.4MM PAST END OF RETAINING RIB (FIGURE R).

- D. ROPE MUST BE POSITIONED AGAINST PULLEY TOP FLANGE.

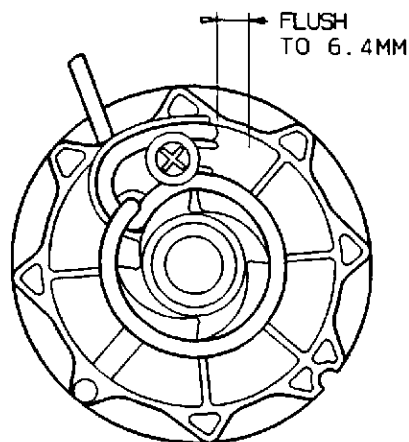

FIGURE R

22. RECOIL SPRING ASSEMBLY - CONTINUED

- E. WITH ROPE FULLY EXTENDED, PULLEY SHOULD BE ABLE TO TURN AT LEAST ONE (1) TURN, BUT NO MORE THAN TWO (2) TURNS, CLOCKWISE BEFORE SPRING BOTTOMS OUT.
- F. ROPE RETURN SHOULD BE RAPID, AND WITHOUT DRAG. THE HANDLE MUST SIT IN IT'S CORRECT POSITION WITHOUT SAG.
- G. ALIGN FAN HOUSING WITH CHASSIS, PULLING STARTER ROPE TO ALIGN PULLEY WITH STARTER DOGS. SECURE WITH FOUR (4) SCREWS. TORQUE TO SPECIFICATION.

IMPORTANT NOTE: BE SURE NOT TO PINCH SPARK PLUG WIRE.

15. CYLINDER SHIELD ASSEMBLY

- A. TAKING CARE TO PROPERLY ALIGN CYLINDER SHIELD, ASSEMBLE CYLINDER SHIELD TO CHASSIS USING THREE (3) SCREWS. TORQUE TO SPECIFICATION. (FIGURE AB)
- B. ON LOW EMISSION ENGINES ONLY.
SECURE 3M REFLECTIVE TAPE ON INSIDE OF CYLINDER SHIELD AS SHOWN: ENSURE REFLECTIVE TAPE HAS BEEN FULLY PRESSED INTO POSITION ON ENTIRE SURFACE AREA WHERE THE 3M REFLECTIVE TAPE IS SECURED, MUST BE CLEAN.

23. FRONT AND REAR HANDLE ASSEMBLY-AV ONLY

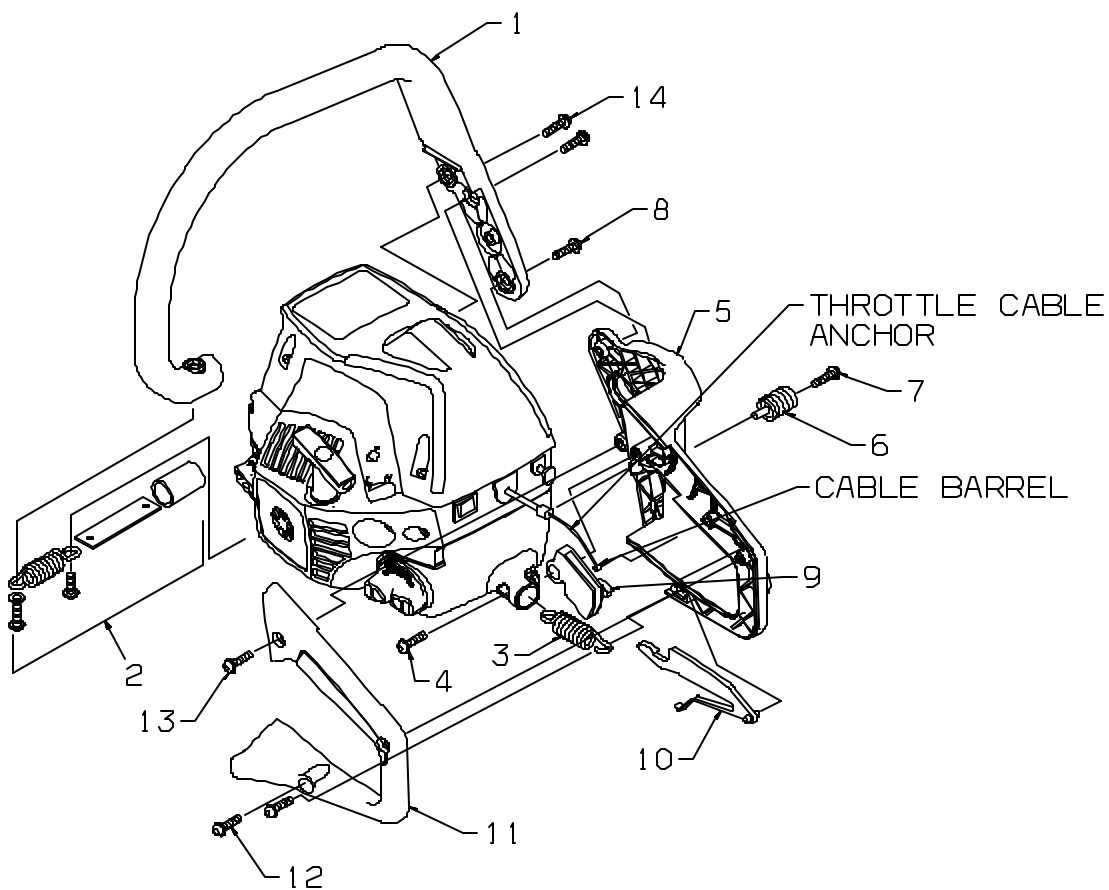

NOTE: POWERHEAD PICTURE MAY VARY DEPENDING ON MODEL.

24. FRONT AND REAR HANDLE ASSEMBLY - AV ONLY-CONTINUED

ITEM	DESCRIPTION	QTY	COMMENTS
1	FRONT HANDLE	1	
2	FRONT SPRING ASSEMBLY	1	
3	REAR SPRING	1	
4	SCREW-REAR SPRING	1	M5.28-1.8 X 16 MM PLASTITE
5	REAR HANDLE	1	
6	REAR BOTTOM SPRING	1	
7	SCREW-REAR BOTTOM SPRING	1	#10-14 X 19 MM PLASTITE
8	SCREW-FRONT/REAR HANDLE	2	#10-14 X 14 MM PLASTITE
9	THROTTLE TRIGGER	1	
10	THROTTLE LOCKOUT	1	
11	REAR HANDLE COVER	1	
12	SCREW-COVER/SPRING/REAR HANDLE	1	
13	SCREW-COVER/REAR HANDLE	2	M5.28 X 16 MM PLASTITE
14	SCREW-REAR TOP SPRING	1	#10-14 X 27 MM PLASTITE

A. POSITION FRONT HANDLE ON SAW AND INSTALL AV SPRING ASSEMBLY TO FRONT HANDLE, AND BOTTOM OF CHASSIS WITH TWO (2) SCREWS. TORQUE TO SPECIFICATION.

NOTE: MACHINE SCREW GOES INTO HANDLE.

B. ATTACH LOWER, AND UPPER ISOLATOR SPRING TO HANDLE ASSEMBLY WITH SCREWS (#7& #14).

C. INSTALL REAR AV SPRING (#5) IN CHASSIS POCKET WITH SCREW (#4). TORQUE TO SPECIFICATION.

D. INSTALL AV SPRING (#6)
NOTE: 1/8" HEX DRIVER REQUIRED.

E. ASSEMBLE FRONT AND REAR HANDLES TOGETHER USING TWO (2) SCREWS (#8). TORQUE TO SPECIFICATION.

F. PRESS THROTTLE CABLE ANCHOR INTO POCKET IN REAR HANDLE.

G. DROP BARREL END OF CABLE INTO POCKET IN REAR HANDLE.

H. SLIDE TRIGGER OVER SCREW BOSS WHILE ENSURING THAT THE THROTTLE CABLE LAYS ON TOP OF THE SEMI-CIRCULAR BOSS ON THE UPPER REAR PORTION OF THE TRIGGER.

I. INSERT THROTTLE LOCKOUT CATCH THROUGH SLOT IN TRIGGER WHILE COMPRESSING THE THIN SPRING ARM TO ENSURE THAT THE SPRING FINGER RIDES ON TOP OF THE RIB IN THE TRIGGER. DROP PIN BOSS AT THE REAR OF THE LOCKOUT INTO THE POCKET IN THE REAR HANDLE.

J. ASSEMBLE REAR HANDLE COVER TO REAR HANDLE (FIGURE AD). ALIGN THROTTLE LOCKOUT BOSS, AND SCREW BOSSES WITH POCKETS IN REAR HANDLE COVER. SCREW TOGETHER WITH THREE (3) SCREWS.

NOTE: ENSURE REAR AV SPRING (#3) IS POSITIONED SO THAT THE BOTTOM REAR HANDLE COVER SCREW (#12) GOES THROUGH THE SPRING HOOK, AND ASSEMBLES TO THE REAR HANDLE , AND REAR HANDLE COVER.

20. FRONT AND REAR HANDLE ASSEMBLY - NON-AV ONLY - CONTINUED

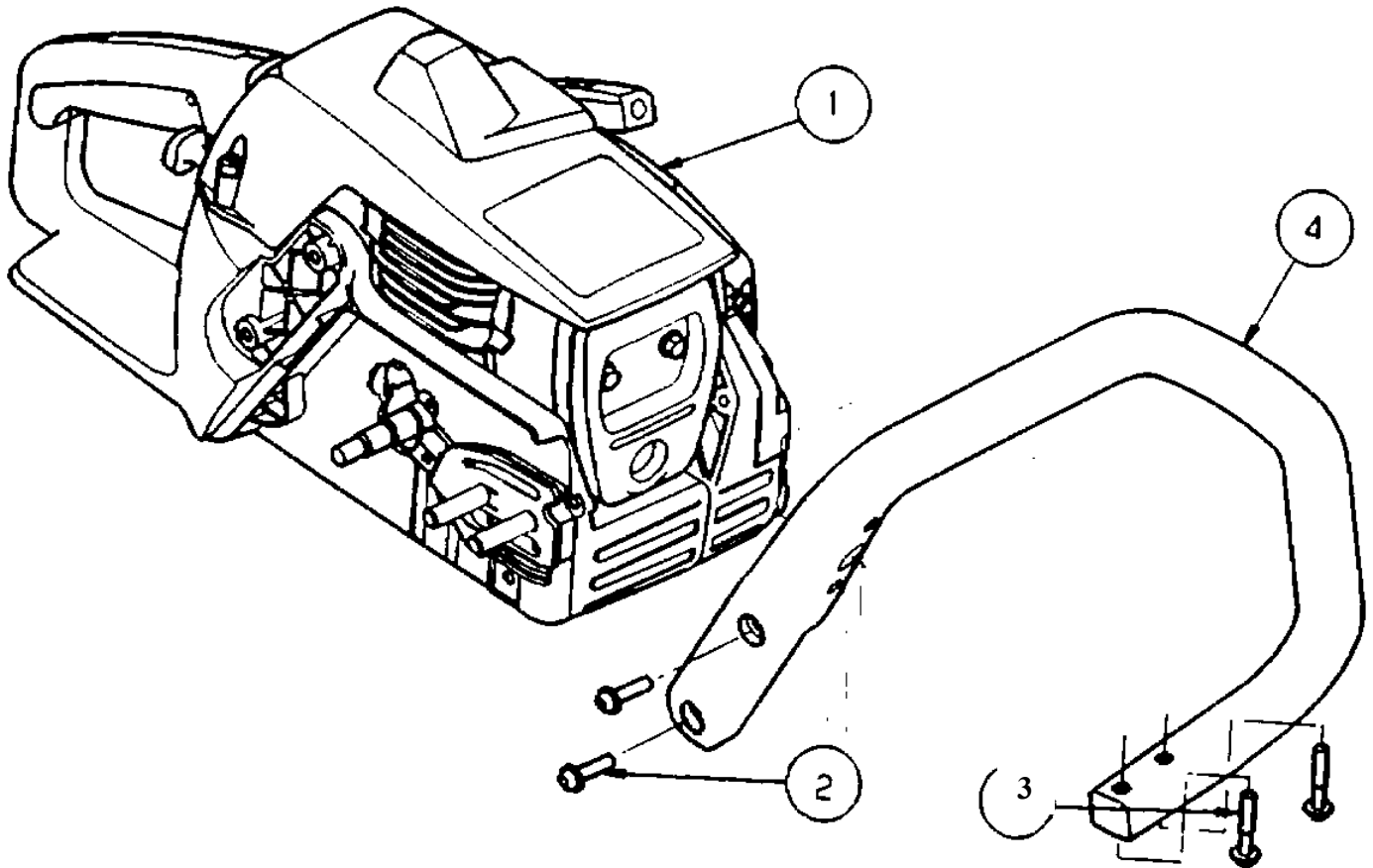

- A. POSITION HANDLE BAR, (#4) ON SAW (#1) USING SCREWS (2-#2 AND 2-#3). TORQUE TO SPECIFICATION.

25. CLUTCH ASSEMBLY AND CHAIN CATCHER

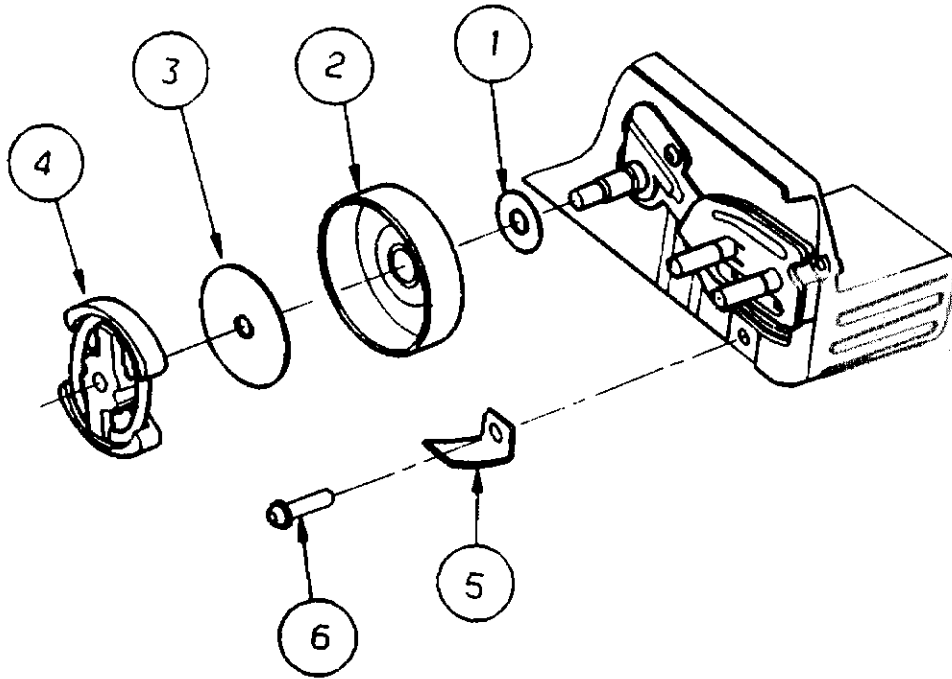

- A. INSTALL THRUST WASHER (#1) ONTO CRANKSHAFT.
- B. INSTALL CLUTCH DRUM ASSEMBLY (#2) ONTO CRANKSHAFT.
- C. PLACE CLUTCH WASHER (#3) INSIDE CLUTCH DRUM, AND THREAD CLUTCH ASSEMBLY (#4) ONTO CRANKSHAFT. TORQUE TO SPECIFICATION.

NOTE: CLUTCH IS LEFT HAND THREAD.
- D. INSTALL CHAIN CATCHER (#5) WITH SCREW (#6) IN CHASSIS POCKET. TORQUE TO SPECIFICATION.
- E. INSTALL BAR ADJUSTMENT PIN, SCREW, AND RETAINER INTO CLUTCH COVER (FIGURE S). ADJUST PIN MUST BE POSITIONED ABOVE THE CENTER LINE OF THE SCREW.

(NOTE: DOES NOT APPLY ON UNITS WITH INTEGRAL BAR ADJUST SYSTEM OR TOOLES ADJUST)

IMPORTANT NOTE: RETAINER MUST BE ORIENTED AS SHOWN IN FIGURE AI.
- F. BAR CLAMP, BAR CLAMP NUTS, AND TORQUE TO SPECIFICATION.

26. INSTALL BAR ADJUSTMENT PIN, SCREW, AND RETAINER INTO CLUTCH COVER. ADJUST PIN MUST BE POSITIONED ABOVE THE CENTER LINE OF THE SCREW.
IMPORTANT NOTE: RETAINER MUST BE ORIENTED AS SHOWN IN FIGURE.

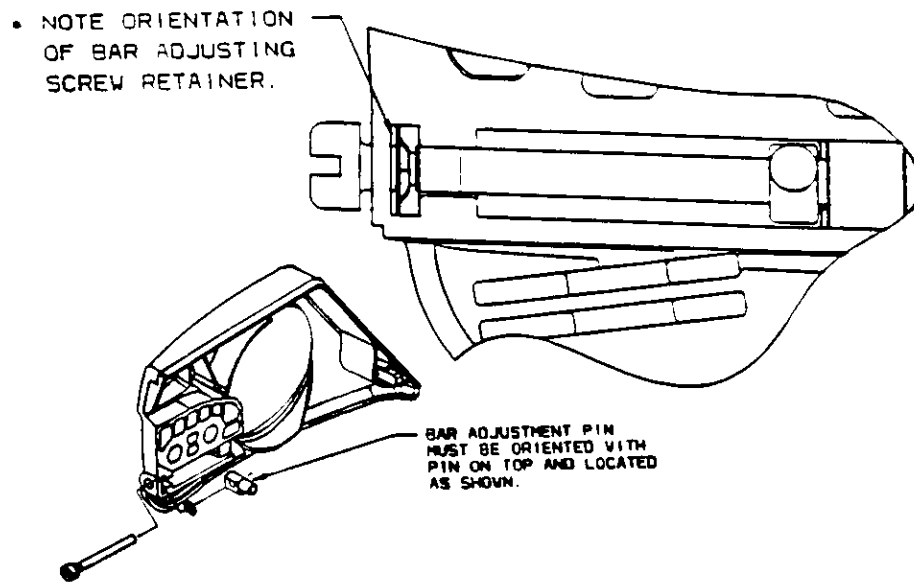

(FIGURE 5)

For Discount Poulan Poulan Pro Parts Call 606-678-9623 or 606-561-4983