

For Parts Call K&T 606-678-9623 or 606-561-4983

IMPORTANT MANUAL

Do Not Throw Away

Poulan PRO

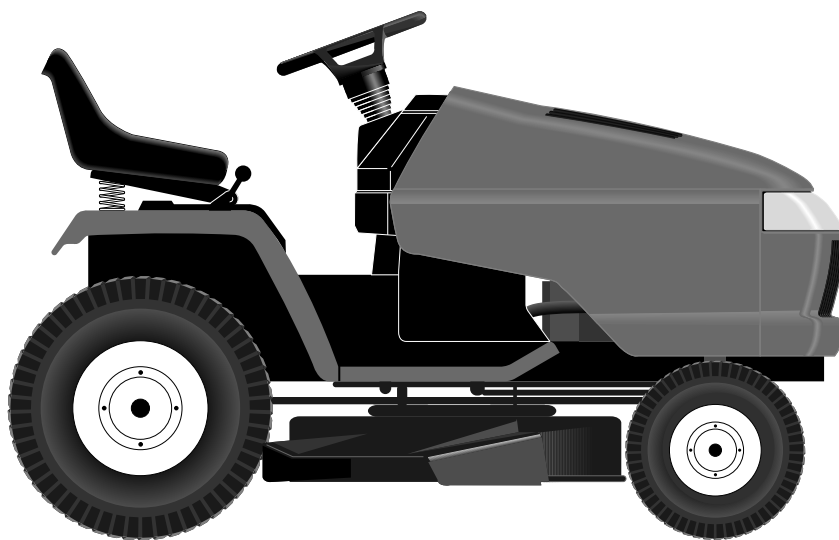

OWNER'S MANUAL

MODEL:

PRGT22H50B

LAWN TRACTOR

Always Wear Eye Protection During Operation



WARNING:

Read the Owner's Manual and follow all Warnings and Safety Instructions. Failure to do so can result in serious injury.

177937 Rev. 4 06.28.01 RH
Printed in U.S.A.

SAFETY RULES



SAFE OPERATION PRACTICES FOR RIDE-ON MOWERS



IMPORTANT: THIS CUTTING MACHINE IS CAPABLE OF AMPUTATING HANDS AND FEET AND THROWING OBJECTS. FAILURE TO OBSERVE THE FOLLOWING SAFETY INSTRUCTIONS COULD RESULT IN SERIOUS INJURY OR DEATH.

I. GENERAL OPERATION

- Read, understand, and follow all instructions in the manual and on the machine before starting.
- Only allow responsible adults, who are familiar with the instructions, to operate the machine.
- Clear the area of objects such as rocks, toys, wire, etc., which could be picked up and thrown by the blade.
- Be sure the area is clear of other people before mowing. Stop machine if anyone enters the area.
- Never carry passengers.
- Do not mow in reverse unless absolutely necessary. Always look down and behind before and while backing.
- Be aware of the mower discharge direction and do not point it at anyone. Do not operate the mower without either the entire grass catcher or the guard in place.
- Slow down before turning.
- Never leave a running machine unattended. Always turn off blades, set parking brake, stop engine, and remove keys before dismounting.
- Turn off blades when not mowing.
- Stop engine before removing grass catcher or unclogging chute.
- Mow only in daylight or good artificial light.
- Do not operate the machine while under the influence of alcohol or drugs.
- Watch for traffic when operating near or crossing roadways.
- Use extra care when loading or unloading the machine into a trailer or truck.
- Data indicates that operators, age 60 years and above, are involved in a large percentage of riding mower-related injuries. These operators should evaluate their ability to operate the riding mower safely enough to protect themselves and others from serious injury.
- Keep machine free of grass, leaves or other debris build-up which can touch hot exhaust / engine parts and burn. Do not allow the mower deck to plow leaves or other debris which can cause build-up to occur. Clean any oil or fuel spillage before operating or storing the machine. Allow machine to cool before storage.

II. SLOPE OPERATION

Slopes are a major factor related to loss-of-control and tipover accidents, which can result in severe injury or death. All slopes require extra caution. If you cannot back up the slope or if you feel uneasy on it, do not mow it.

DO:

- Mow up and down slopes, not across.
- Remove obstacles such as rocks, tree limbs, etc.
- Watch for holes, ruts, or bumps. Uneven terrain could overturn the machine. *Tall grass can hide obstacles.*
- Use slow speed. Choose a low gear so that you will not have to stop or shift while on the slope.
- Follow the manufacturer's recommendations for wheel weights or counterweights to improve stability.
- Use extra care with grass catchers or other attachments. These can change the stability of the machine.
- Keep all movement on the slopes *slow* and *gradual*. Do not make sudden changes in speed or direction.

- Avoid starting or stopping on a slope. If tires lose traction, disengage the blades and proceed slowly *straight* down the slope.

DO NOT:

- *Do not* turn on slopes unless necessary, and then, turn slowly and gradually downhill, if possible.
- *Do not* mow near drop-offs, ditches, or embankments. The mower could suddenly turn over if a wheel is over the edge of a cliff or ditch, or if an edge caves in.
- *Do not* mow on wet grass. Reduced traction could cause sliding.
- *Do not* try to stabilize the machine by putting your foot on the ground.
- *Do not* use grass catcher on steep slopes.

III. CHILDREN

Tragic accidents can occur if the operator is not alert to the presence of children. Children are often attracted to the machine and the mowing activity. *Never* assume that children will remain where you last saw them.

- Keep children out of the mowing area and under the watchful care of another responsible adult.
- Be alert and turn machine off if children enter the area.
- Before and when backing, look behind and *down* for small children.
- Never carry children. They may fall off and be seriously injured or interfere with safe machine operation.
- Never allow children to operate the machine.
- Use extra care when approaching blind corners, shrubs, trees, or other objects that may obscure vision.

IV. SERVICE

- Use extra care in handling gasoline and other fuels. They are flammable and vapors are explosive.
 - Use only an approved container.
 - Never remove gas cap or add fuel with the engine running. Allow engine to cool before refueling. Do not smoke.
 - Never refuel the machine indoors.
 - Never store the machine or fuel container inside where there is an open flame, such as a water heater.
- Never run a machine inside a closed area.
- Keep nuts and bolts, especially blade attachment bolts, tight and keep equipment in good condition.
- Never tamper with safety devices. Check their proper operation regularly.
- Keep machine free of grass, leaves, or other debris build-up. Clean oil or fuel spillage. Allow machine to cool before storing.
- Stop and inspect the equipment if you strike an object. Repair, if necessary, before restarting.
- Never make adjustments or repairs with the engine running.
- Grass catcher components are subject to wear, damage, and deterioration, which could expose moving parts or allow objects to be thrown. Frequently check components and replace with manufacturer's recommended parts, when necessary.
- Mower blades are sharp and can cut. Wrap the blade(s) or wear gloves, and use extra caution when servicing them.
- Check brake operation frequently. Adjust and service as required.

SAFETY RULES

Safe Operation Practices for Ride-On Mowers



- Be sure the area is clear of other people before mowing. Stop machine if anyone enters the area.
- Never carry passengers or children even with the blades off.
- Do not mow in reverse unless absolutely necessary. Always look down and behind before and while backing.
- Never carry children. They may fall off and be seriously injured or interfere with safe machine operation.
- Keep children out of the mowing area and under the watchful care of another responsible adult.
- Be alert and turn machine off if children enter the area.
- Before and when backing, look behind and down for small children.
- Mow up and down slopes (15° Max), not across.
- Remove obstacles such as rocks, tree limbs, etc.
- Watch for holes, ruts, or bumps. Uneven terrain could overturn the machine. Tall grass can hide obstacles.
- Use slow speed. Choose a low gear so that you will not have to stop or shift while on the slope.
- Avoid starting or stopping on a slope. If tires lose traction, disengage the blades and proceed slowly straight down the slope.
- If machine stops while going uphill, disengage blades, shift into reverse and back down slowly.
- Do not turn on slopes unless necessary, and then, turn slowly and gradually downhill, if possible.



Look for this symbol to point out important safety precautions. It means **CAUTION!!! BECOME ALERT!!! YOUR SAFETY IS INVOLVED.**



CAUTION: In order to prevent accidental starting when setting up, transporting, adjusting or making repairs, always disconnect spark plug wire and place wire where it cannot contact spark plug.



CAUTION: Do not coast down a hill in neutral, you may lose control of the tractor.



CAUTION: Tow only the attachments that are recommended by and comply with specifications of the manufacturer of your tractor. Use common sense when towing. Operate only at the lowest possible speed when on a slope. Too heavy of a load, while on a slope, is dangerous. Tires can lose traction with the ground and cause you to lose control of your tractor.



WARNING



Engine exhaust, some of its constituents, and certain vehicle components contain or emit chemicals known to the State of California to cause cancer and birth defects or other reproductive harm.



WARNING



Battery posts, terminals and related accessories contain lead and lead compounds, chemicals known to the State of California to cause cancer and birth defects or other reproductive harm. Wash hands after handling.

PRODUCT SPECIFICATIONS

GASOLINE CAPACITY AND TYPE:	3.5 GALLONS UNLEADED REGULAR
OIL TYPE (API-SF-SJ):	SAE 30 (above 32°F) SAE 5W-30 (below 32°F)
OIL CAPACITY:	W/FILTER: 4.0 PINTS W/OFILTER: 3.75 PINTS
SPARK PLUG: (GAP: .040")	CHAMPION RC12YC
GROUND SPEED (MPH):	FORWARD: 0 – 5.8 REVERSE: 0 – 2.1
TIRE PRESSURE:	FRONT: 14 PSI REAR: 10 PSI
CHARGING SYSTEM:	16 AMPS @ 3600 RPM
BATTERY:	AMP/HR: 30 MIN. CCA: 240 CASE SIZE: U1R
BLADE BOLT TORQUE:	27–35 FT. LBS.

CUSTOMER RESPONSIBILITIES

- Read and observe the safety rules.
- Follow a regular schedule in maintaining, caring for and using your tractor.
- Follow the instructions under “Customer Responsibilities” and “Storage” sections of this owner’s manual.

WARNING: This tractor is equipped with an internal combustion engine and should not be used on or near any unimproved forest-covered, brush-covered or grass-covered land unless the engine’s exhaust system is equipped with a spark arrester meeting applicable local or state laws (if any). If a spark arrester is used, it should be maintained in effective working order by the operator.

A spark arrester for the muffler is available through your nearest authorized service centre/department (See REPAIR PARTS section of this manual).

CONGRATULATIONS on your purchase of a new tractor. It has been designed, engineered and manufactured to give you the best possible dependability and performance.

Should you experience any problem you cannot easily remedy, please contact your nearest authorized service center/department. We have competent, well-trained technicians and the proper tools to service or repair this tractor.

Please read and retain this manual. The instructions will enable you to assemble and maintain your tractor properly. Always observe the “SAFETY RULES”.

TABLE OF CONTENTS

SAFETY RULES	2-3
PRODUCT SPECIFICATIONS	4
CUSTOMER RESPONSIBILITIES	4, 16-19
ASSEMBLY	6-9
OPERATION	10-15
MAINTENANCE SCHEDULE	16

SERVICE AND ADJUSTMENTS	20-26
STORAGE	27
TROUBLESHOOTING	28-29
REPAIR PARTS - TRACTOR	32-46
WARRANTY	50

UNASSEMBLED PARTS

Steering Wheel

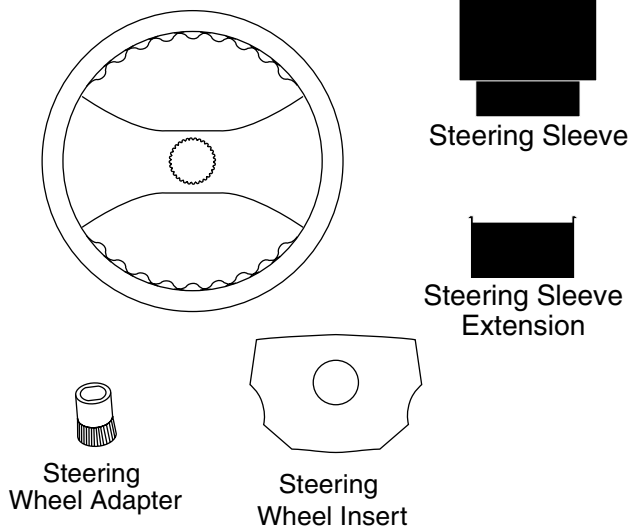

Gauge Wheel

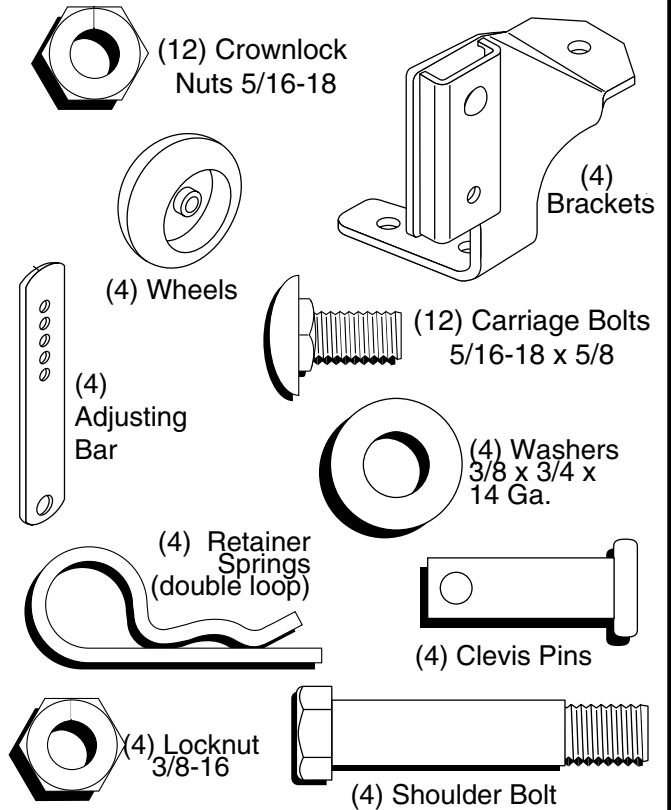

Seat

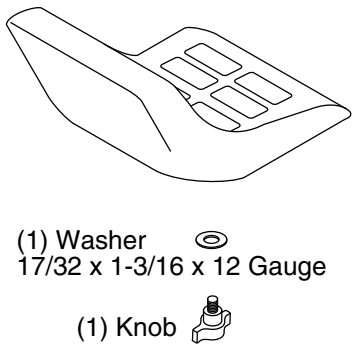

Nose Roller

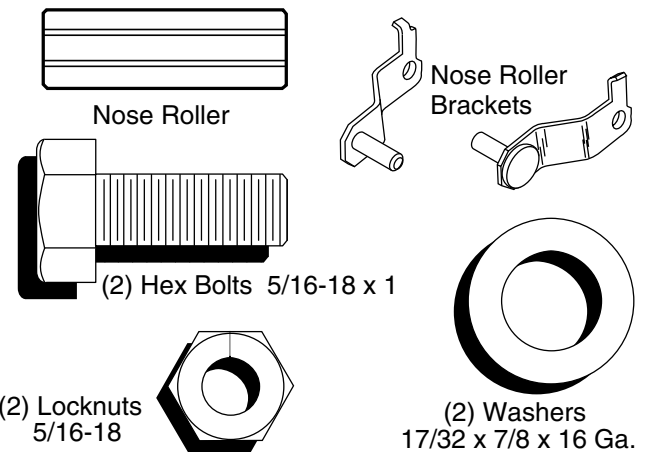

Mower

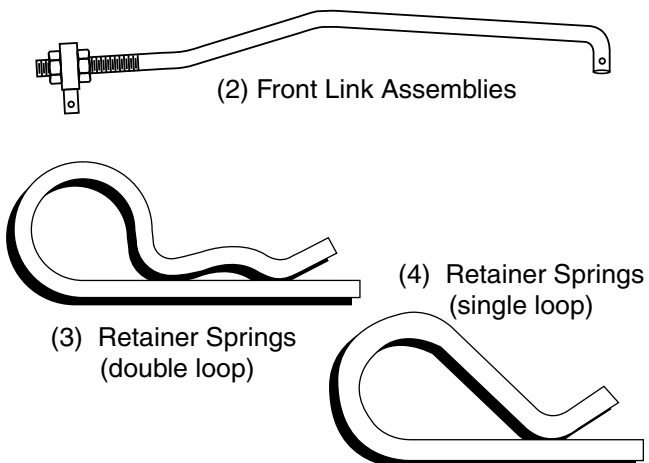

(1) Oil Drain Tube For Future Use

Keys



Slope Sheet

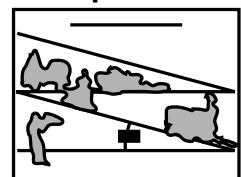

ASSEMBLY

Your new tractor has been assembled at the factory with exception of those parts left unassembled for shipping purposes. To ensure safe and proper operation of your tractor all parts and hardware you assemble must be tightened securely. Use the correct tools as necessary to insure proper tightness.

TOOLS REQUIRED FOR ASSEMBLY

A socket wrench set will make assembly easier. Standard wrench sizes are listed.

- | | |
|------------------|---------------------------------|
| (1) Pliers | (1) Tire pressure gauge |
| (2) 9/16" wrench | (1) Utility knife |
| (1) 1/2" wrench | (1) 3/4" socket w/drive ratchet |

When right or left hand is mentioned in this manual, it means when you are in the operating position (seated behind the steering wheel).

TO REMOVE TRACTOR FROM CARTON

UNPACK CARTON

- Remove all accessible loose parts and parts cartons from carton.
- Cut, from top to bottom, along lines on all four corners of carton, and lay panels flat.
- Remove mower and packing materials.
- Check for any additional loose parts or cartons and remove.

BEFORE REMOVING TRACTOR FROM SKID

ATTACH STEERING WHEEL (See Fig. 1)

- Remove hex bolt, lock washer and large flat washer from steering shaft.
- Position front wheels of the tractor so they are pointing straight forward.
- Slide the steering sleeve over the steering shaft.
- Align tabs and press steering sleeve extension into bottom of steering wheel.
- Position steering wheel so cross bars are horizontal (left to right) and slide onto steering wheel adaptor.
- Secure steering wheel to steering shaft with hex bolt, lock washer and large flat washer previously removed. Tighten securely.
- Snap steering wheel insert into center of steering wheel.
- Remove protective materials from tractor hood and grill.

IMPORTANT: CHECK FOR AND REMOVE ANY STAPLES IN SKID THAT MAY PUNCTURE TIRES WHERE TRACTOR IS TO ROLL OFF SKID.

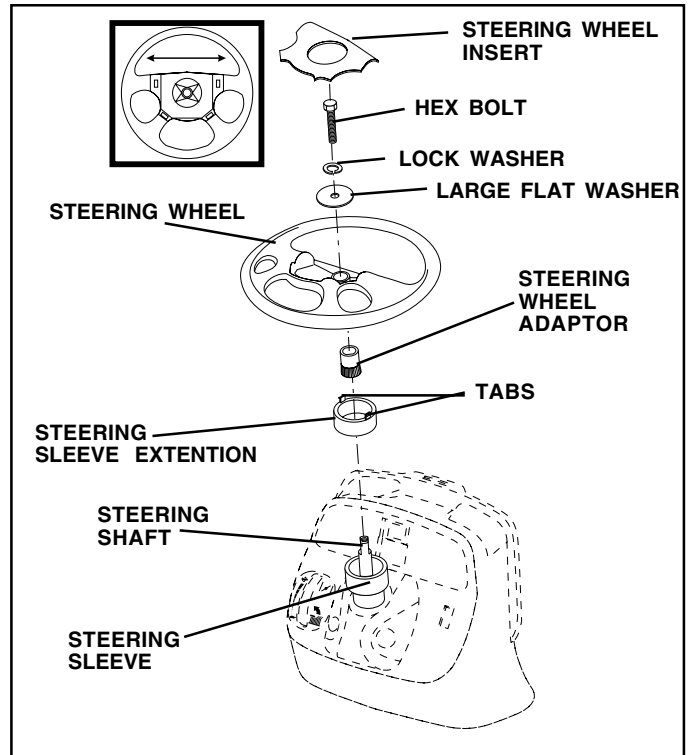

FIG. 1

HOW TO SET UP YOUR TRACTOR

CHECK BATTERY (See Fig. 2)

- Lift hood to raised position.
- If this battery is put into service after month and year indicated on label (label located between terminals) charge battery for minimum of one hour at 6-10 amps. (See "BATTERY" in CUSTOMER RESPONSIBILITIES section of this manual for charging instructions).

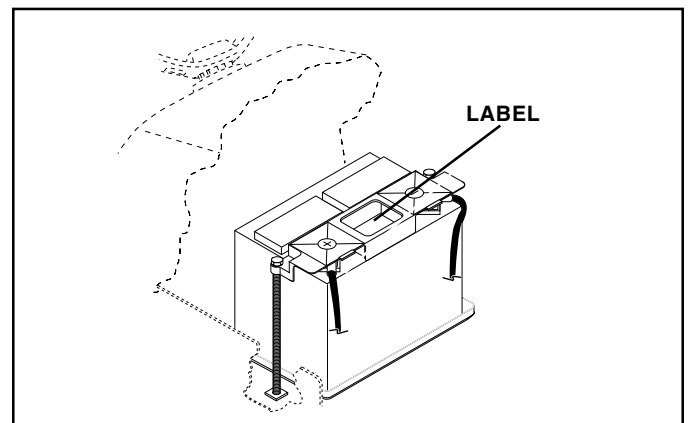

FIG. 2

ASSEMBLY

INSTALL SEAT (See Fig. 3)

Adjust seat before tightening adjustment knob.

- Remove adjustment knob and flat washer securing seat to cardboard packing and set aside for assembly of seat to tractor.
- Pivot seat upward and remove from the cardboard packing. Remove the cardboard packing and discard.
- Place seat on seat pan so head of shoulder bolt is positioned over large slotted hole in pan.
- Push down on seat to engage shoulder bolt in slot and pull seat towards rear of tractor.
- Pivot seat and pan forward and assemble adjustment knob and flat washer loosely. Do not tighten.
- Lower seat into operating position and sit on seat.
- Slide seat until a comfortable position is reached which allows you to press clutch/brake pedal all the way down.
- Get off seat without moving its adjusted position.
- Raise seat and tighten adjustment knob securely.

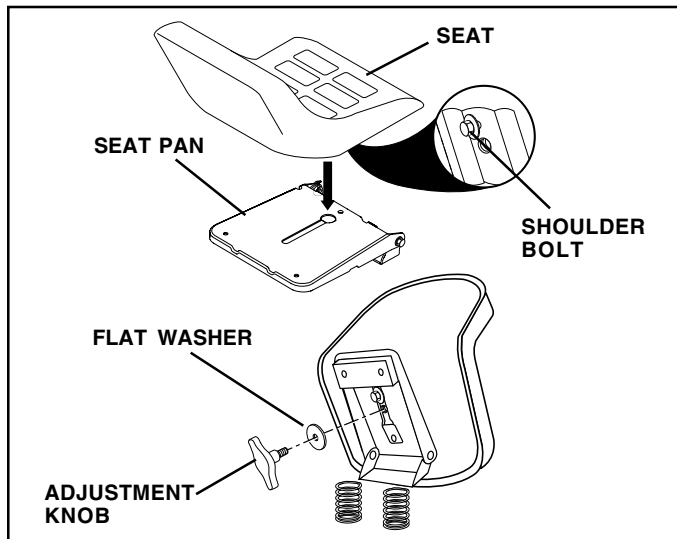

FIG. 3

NOTE: You may now roll or drive your tractor off the skid. Follow the appropriate instruction below to remove the tractor from the skid.

TO ROLL TRACTOR OFF SKID (See Operation section for location and function of controls)

- Press lift lever plunger and raise attachment lift lever to its highest position.
- Release parking brake by depressing brake pedal.
- Place freewheel control in freewheeling position to disengage transmission (See "TO TRANSPORT" in the Operation section of this manual).
- Roll tractor forward off skid.

TO DRIVE TRACTOR OFF SKID (See Operation section for location and function of controls)

WARNING: Before starting, read, understand and follow all instructions in the Operation section of this manual. Be sure tractor is in a well-ventilated area. Be sure the area in front of tractor is clear of other people and objects.

- Be sure all the above assembly steps have been completed.
- Check engine oil level and fill fuel tank with gasoline.
- Place freewheel control in "transmission engaged" position.
- Sit on seat in operating position, depress brake pedal and set the parking brake.
- Press lift lever plunger and raise attachment lift lever to its highest position.
- Start the engine. After engine has started, move throttle control to idle position.
- Release parking brake.
- Slowly move the motion control lever forward and slowly drive tractor off skid.
- Apply brake to stop tractor and set parking brake.
- Turn ignition key to "OFF" position.

Continue with the instructions that follow.

ASSEMBLE GAUGE WHEELS AND BRACKETS TO MOWER DECK (See Fig. 4)

The gauge wheels are designed to keep the mower deck in proper position when operating mower. Be sure they are properly adjusted to ensure optimum mower performance.

- Attach front gauge wheel brackets marked front left (FL), front right (FR) to mower deck using (3) carriage bolts and (3) locknuts. For ease of installation do not tighten locknuts until all carriage bolts have been installed.
- Attach rear gauge wheel brackets marked rear left (RL), rear right (RR) to mower deck using (3) carriage bolts and (3) locknuts. For ease of installation do not tighten locknuts until all carriage bolts have been installed.
- Slide gauge wheel bar down into bracket channel. Be sure that gauge wheel bar aligning holes are on top. Assemble gauge wheels as shown using shoulder bolts, 3/8 washers and 3/8-16 center locknuts and tighten securely.
- Adjust gauge wheels to highest position for ease of mower deck assembly.
- Adjust gauge wheels before operating mower as shown in the operation section of this manual.

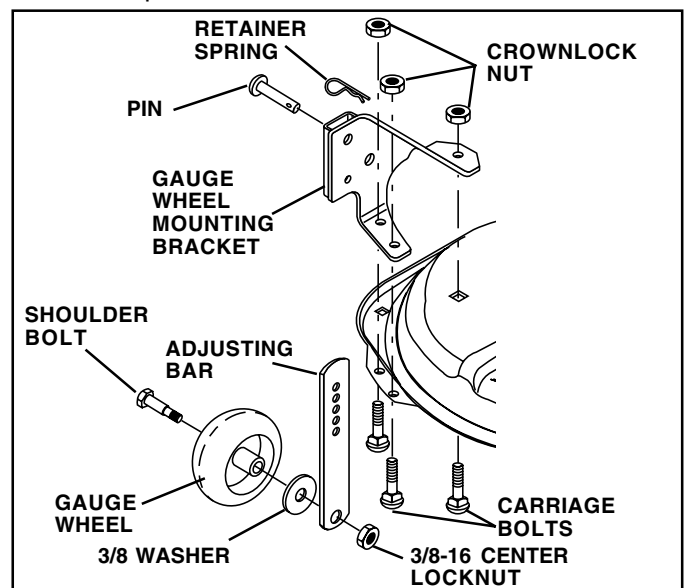

FIG. 4

ASSEMBLY

TO ATTACH NOSE ROLLER (See Fig. 5)

- Position brackets, 17/32 x 7/8 x 16 gauge washers, and nose roller between deck mounting brackets as shown. Be sure to position brackets on correct side, as shown.
- Install hex bolts and lock nuts as shown. Tighten hardware securely.

NOTE: Be sure bracket tabs are positioned in tab holes in deck brackets.

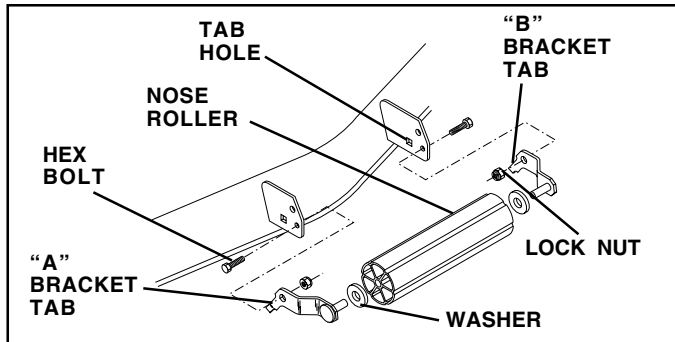

FIG. 5

INSTALL MOWER AND DRIVE BELT (See Figs. 6 and 7)

Be sure tractor is on level surface and mower suspension arms are raised with attachment lift control. Engage parking brake.

- Cut and remove ties securing anti-sway bar and belts. Swing anti-sway bar to left side of mower deck.

- Slide mower under tractor with deflector shield to right side of tractor.

IMPORTANT: CHECK BELT FOR PROPER ROUTING IN ALL MOWER PULLEY GROOVES. INSTALL BELT INTO ELECTRIC CLUTCH PULLEY GROOVE.

- Install one front link in top hole of the L.H. front mower bracket and L.H. front suspension bracket. Retain with two single loop retainer springs as shown.
- Install second front link in R.H. front suspension bracket only and retain with single loop retainer spring as shown.
- Slide right side of mower back and install link in top hole of R.H. front mower bracket. Retain with single loop retainer spring as shown.
- Turn height adjustment knob counterclockwise until it stops.
- Lower mower linkage with attachment lift control.
- Place the suspension arms on inward pointing deck pins. If necessary, rock and raise front of mower to align deck pins with the holes in suspension arms. Retain with double loop retainer springs with loops down as shown.
- Connect anti-sway bar to chassis bracket under left footrest and retain with double loop retainer spring.
- Turn height adjustment knob clockwise to remove slack from mower suspension.
- Raise deck to highest position.
- Adjust gauge wheels before operating mower as shown in the Operation section of this manual.

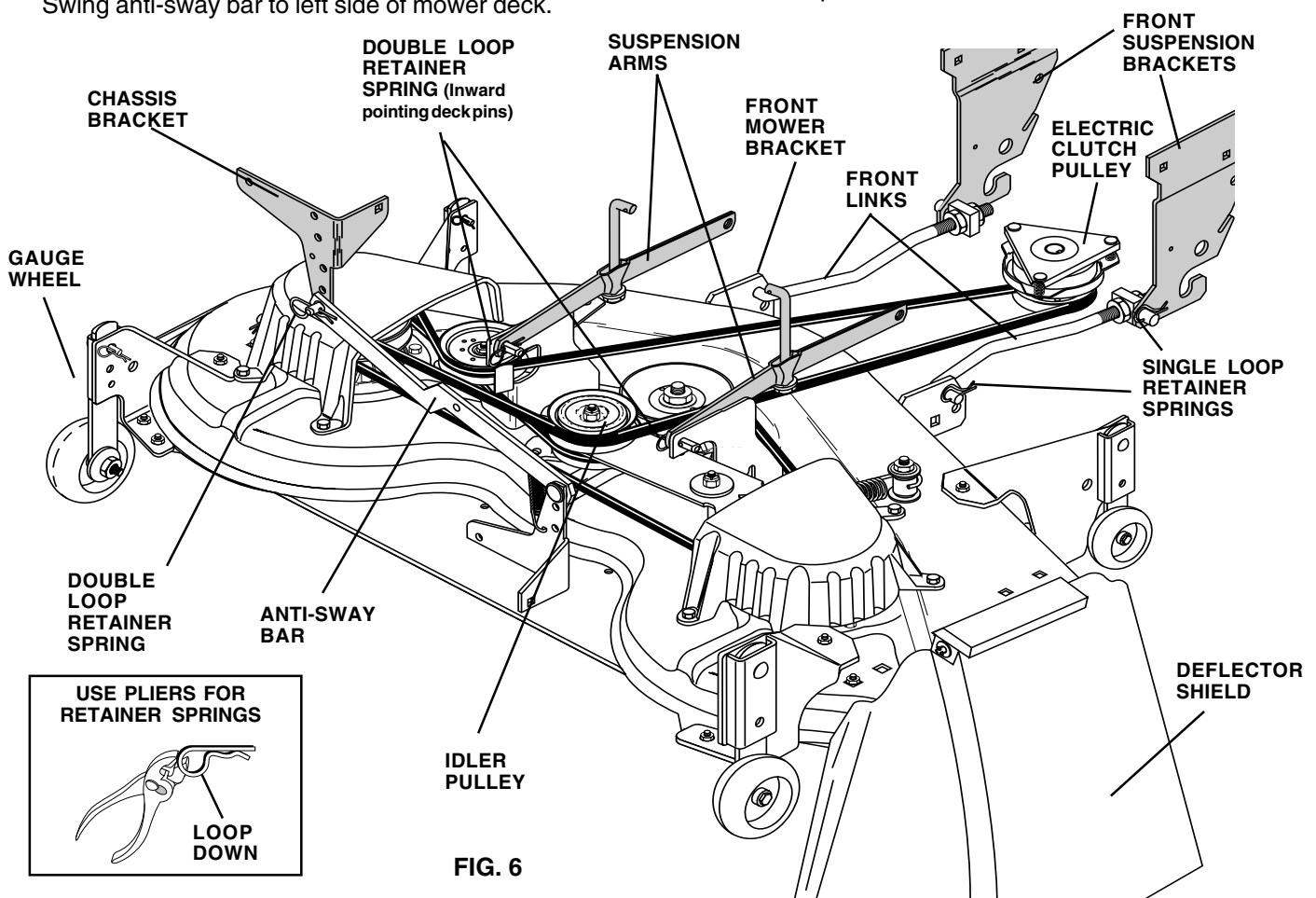

FIG. 6

ASSEMBLY

✓ **CHECKLIST**

CHECK TIRE PRESSURE

The tires on your tractor were overinflated at the factory for shipping purposes. Correct tire pressure is important for best cutting performance.

- Reduce tire pressure to PSI shown in "PRODUCT SPECIFICATIONS" section of this manual.

CHECK MOWER LEVELNESS

For best cutting results, mower should be properly leveled. See "TO LEVEL MOWER HOUSING" in the Service and Adjustments section of this manual.

CHECK FOR PROPER POSITION OF ALL BELTS

See the figures that are shown for replacing motion, mower drive, and mower blade drive belts in the Service and Adjustments section of this manual. Verify that the belts are routed correctly.

BEFORE YOU OPERATE AND ENJOY YOUR NEW TRACTOR, WE WISH TO ASSURE THAT YOU RECEIVE THE BEST PERFORMANCE AND SATISFACTION FROM THIS QUALITY PRODUCT.

PLEASE REVIEW THE FOLLOWING CHECKLIST:

- ✓ All assembly instructions have been completed.
- ✓ No remaining loose parts in carton.
- ✓ Battery is properly prepared and charged. (Minimum 1 hour at 6 amps).
- ✓ Seat is adjusted comfortably and tightened securely.
- ✓ All tires are properly inflated. (For shipping purposes, the tires were overinflated at the factory).
- ✓ Be sure mower deck is properly leveled side-to-side/ front-to-rear for best cutting results. (Tires must be properly inflated for leveling).
- ✓ Check mower and drive belts. Be sure they are routed properly around pulleys and inside all belt keepers.
- ✓ Check wiring. See that all connections are still secure and wires are properly clamped.
- ✓ Before driving tractor, be sure freewheel control is in drive position.

WHILE LEARNING HOW TO USE YOUR TRACTOR, PAY EXTRA ATTENTION TO THE FOLLOWING IMPORTANT ITEMS:

- ✓ Engine oil is at proper level.
- ✓ Fuel tank is filled with fresh, clean, regular unleaded gasoline.
- ✓ Become familiar with all controls - their location and function. Operate them before you start the engine.
- ✓ Be sure brake system is in safe operating condition.
- ✓ It is important to purge the transmission before operating your tractor for the first time. Follow proper starting and transmission purging instructions (See "TO START ENGINE" and "PURGE TRANSMISSION" in Operation section of this manual).

OPERATION

These symbols may appear on your tractor or in literature supplied with the product. Learn and understand their meaning.

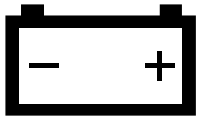

BATTERY



CAUTION OR WARNING



REVERSE



FORWARD



FAST



SLOW

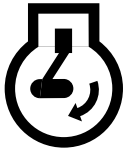

ENGINE ON



ENGINE OFF



OIL PRESSURE

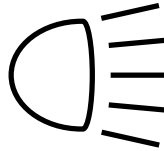

LIGHTS ON



OVER TEMP LIGHT



MOWER LIFT



FUEL

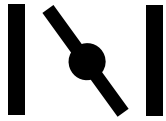

CHOKE

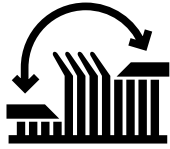

MOWER HEIGHT



PARKING BRAKE LOCKED



UNLOCKED



ATTACHMENT CLUTCH ENGAGED



REVERSE



NEUTRAL



HIGH



LOW

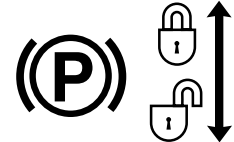

PARKING BRAKE



IGNITION



ATTACHMENT CLUTCH DISENGAGED



KEEP AREA CLEAR



SLOPE HAZARDS



(SEE SAFETY RULES SECTION)



DANGER, KEEP HANDS AND FEET AWAY

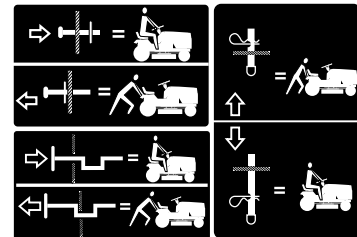

FREE WHEEL (Automatic Models only)

OPERATION

KNOW YOUR TRACTOR

READ THIS OWNER'S MANUAL AND SAFETY RULES BEFORE OPERATING YOUR TRACTOR.

Compare the illustrations with your tractor to familiarize yourself with the location of various controls and adjustments. Save this manual for future reference.

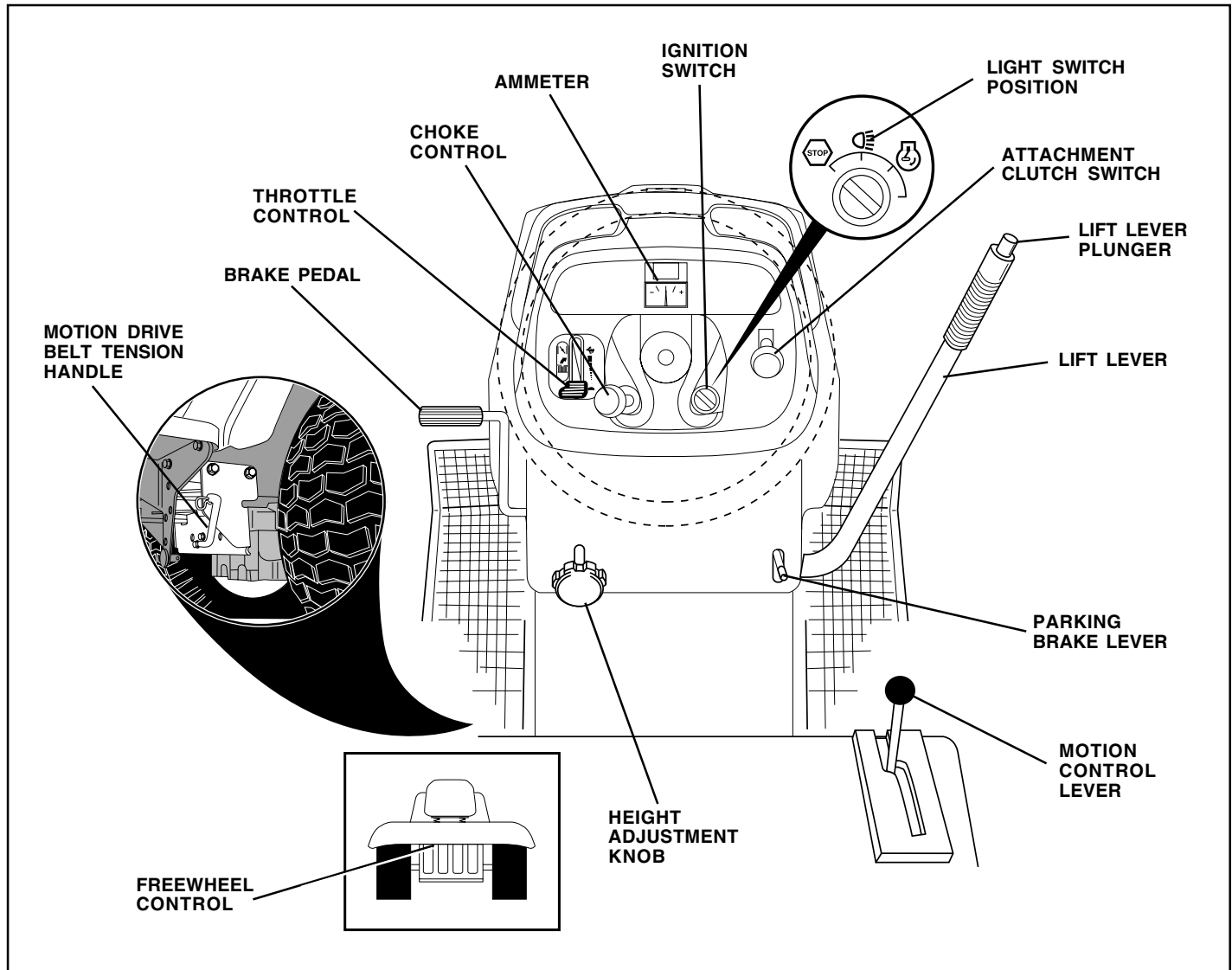

FIG. 7

Our tractors conform to the safety standards of the American National Standards Institute.

ATTACHMENT CLUTCH SWITCH - Used to engage mower blades or other attachments mounted to your tractor.

LIFT LEVER - Used to raise and lower mower deck or other attachments mounted to your tractor.

BRAKE PEDAL - Used for braking the tractor and starting the engine.

MOTION CONTROL LEVER - Selects the speed and direction of tractor.

CHOKE CONTROL - Used when starting a cold engine.

LIGHT SWITCH - Turns the headlights on and off.

LIFT LEVER PLUNGER - Used to release attachment lift lever when changing its position.

THROTTLE CONTROL - Used to control engine speed.

FREEWHEEL CONTROL - Disengages transmission for pushing or slowly towing the tractor with the engine off.

IGNITION SWITCH - Used to start and stop the engine.

AMMETER - Indicates battery charging(+) or discharging(-).

PARKING BRAKE LEVER - Locks brake pedal into the brake position.

HEIGHT ADJUSTMENT KNOB - Used to adjust the mower height.

MOTION DRIVE BELT TENSION HANDLE - Used when changing motion drive belt and, if necessary, starting engine under extremely cold conditions.

OPERATION



The operation of any tractor can result in foreign objects thrown into the eyes, which can result in severe eye damage. Always wear safety glasses or eye shields while operating your tractor or performing any adjustments or repairs. We recommend a wide vision safety mask over spectacles or standard safety glasses.

HOW TO USE YOUR TRACTOR

TO SET PARKING BRAKE (See Fig. 8)

Your tractor is equipped with an operator presence sensing switch. When engine is running, any attempt by the operator to leave the seat without first setting the parking brake will shut off the engine.

- Depress brake pedal into full "BRAKE" position and hold.
- Place parking brake lever in "ENGAGED" position and release pressure from brake pedal. Pedal should remain in "BRAKE" position. Make sure parking brake will hold tractor secure.

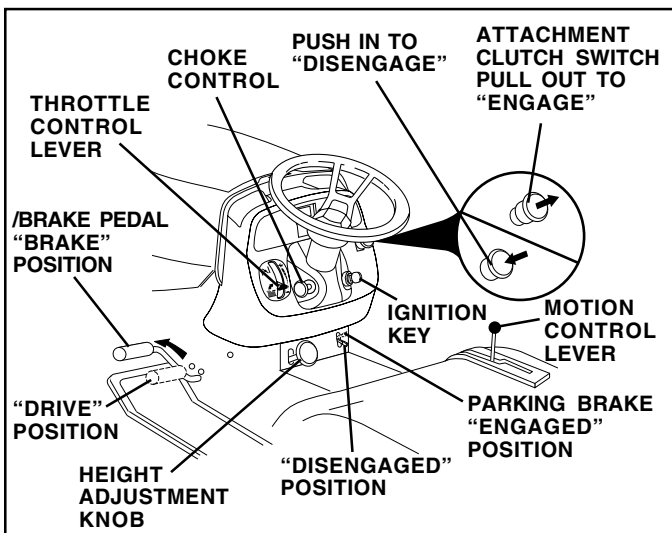

FIG. 8

MOWER BLADES -

- To stop mower blades, move attachment clutch switch to "DISENGAGED" position.

GROUND DRIVE -

- To stop ground drive, depress brake pedal into full "BRAKE" position.

IMPORTANT: THE MOTION CONTROL LEVER RETURNS TO NEUTRAL (N) POSITION WHEN THE BRAKE PEDAL IS FULLY DEPRESSED.

ENGINE -

- Move throttle control to slow position.

NOTE: Failure to move throttle control to slow position and allowing engine to idle before stopping may cause engine to "backfire".

- Turn ignition key to "OFF" position and remove key. Always remove key when leaving tractor to prevent unauthorized use.
- Never use choke to stop engine.

IMPORTANT: LEAVING THE IGNITION SWITCH IN ANY POSITION OTHER THAN "OFF" WILL CAUSE THE BATTERY TO BE DISCHARGED, (DEAD).

NOTE: Under certain conditions when tractor is standing idle with the engine running, hot engine exhaust gases may cause "browning" of grass. To eliminate this possibility, always stop engine when stopping tractor on grass areas.



CAUTION: Always stop tractor completely, as described above, before leaving the operator's position; to empty grass catcher, etc.

TO USE THROTTLE CONTROL (See Fig. 8)

Always operate engine at full throttle.

- Operating engine at less than full throttle reduces the battery charging rate.
- Full throttle offers the best mower performance.

TO USE CHOKER CONTROL (See Fig. 8)

Use choke control whenever you are starting a cold engine. Do not use to start a warm engine.

- To engage choke control, pull knob out. Slowly push knob in to disengage.

TO MOVE FORWARD AND BACKWARD (See Fig. 8)



CAUTION: Do not attempt to operate motion control lever when the parking brake is set or when the brake pedal is depressed. Doing so may result in misadjustment to the drive control system.

The direction and speed of movement is controlled by the motion control lever.

- Start tractor with motion control lever in neutral (N) position.
- Release parking brake.
- Slowly move motion control lever to desired position.

TO ADJUST MOWER CUTTING HEIGHT (See Fig. 8)

The cutting height is controlled by turning the height adjustment knob in desired direction.

- Turn knob clockwise (↻) to raise cutting height.
- Turn knob counterclockwise (↺) to lower cutting height.

The cutting height range is approximately 1-1/2" to 4-1/2". The heights are measured from the ground to the blade tip with the engine not running. These heights are approximate and may vary depending upon soil conditions, height of grass and types of grass being mowed.

- The average lawn should be cut to approximately 2-1/2 inches during the cool season and to over 3 inches during hot months. For healthier and better looking lawns, mow often and after moderate growth.
- For best cutting performance, grass over 6 inches in height should be mowed twice. Make the first cut relatively high; the second to desired height.

OPERATION

TO ADJUST GAUGE WHEELS (See Fig. 9)

Gauge wheels are properly adjusted when they are slightly off the ground when mower is at the desired cutting height in operating position. Gauge wheels then keep the deck in proper position to help prevent scalping in most terrain conditions.

NOTE: Adjust gauge wheels with tractor on a flat level surface.

- Adjust mower to desired cutting height (See "TO ADJUST MOWER CUTTING HEIGHT" in the Operation section of this manual).
- Remove retainer spring and clevis pin which secure each gauge wheel bar.
- Lower gauge wheels to ground. Raise gauge wheels slightly to align holes in bracket and gauge wheel bar and insert clevis pin. Gauge wheels should be slightly off the ground.
- Replace retainer spring into clevis pin.
- Be sure all gauge wheels are in the same setting.

IMPORTANT: BE SURE TO READJUST GAUGE WHEELS IF YOU CHANGE THE CUTTING HEIGHT OF THE MOWER DECK.

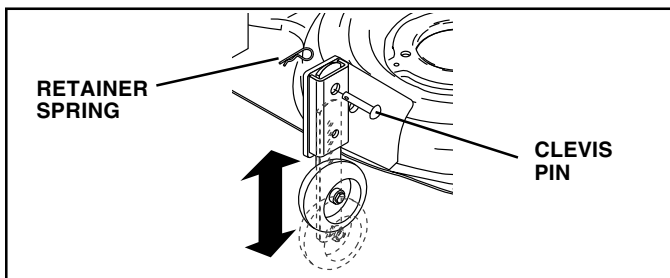

FIG. 9

TO OPERATE MOWER (See Figs. 7 and 10)

Your tractor is equipped with an operator presence sensing switch. Any attempt by the operator to leave the seat with the engine running and the attachment clutch engaged will shut off the engine.

- Select desired height of cut.
- Lower mower with attachment lift control.
- Start mower blades by engaging attachment clutch control.
- TO STOP MOWER BLADES - disengage attachment clutch control.



CAUTION: Do not operate the mower without either the entire grass catcher, on mowers so equipped, or the deflector shield in place.

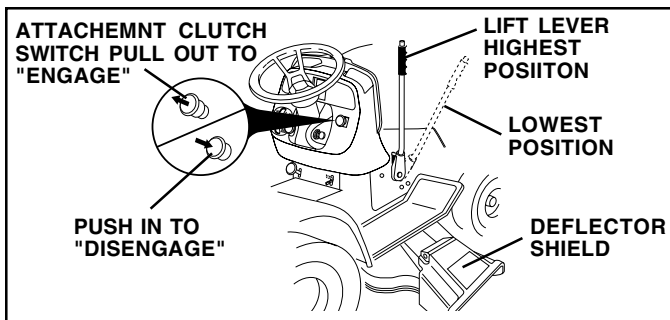

FIG. 10

TO OPERATE ON HILLS



CAUTION: Do not drive up or down hills with slopes greater than 15° and do not drive across any slope.

- Choose the slowest speed before starting up or down hills.
- Avoid stopping or changing speed on hills.
- If stopping is absolutely necessary, push brake pedal quickly to brake position and engage parking brake.

IMPORTANT: THE MOTION CONTROL LEVER RETURNS TO NEUTRAL (N) POSITION WHEN THE BRAKE PEDAL IS FULLY DEPRESSED.

- To restart movement, slowly release parking brake and brake pedal.
- Slowly move motion control lever to slowest setting.
- Make all turns slowly.

TO TRANSPORT (See Figs. 7 and 11)

When pushing or towing your tractor, be sure to disengage transmission by placing freewheel control in freewheeling position. Free wheel control is located at the rear drawbar of tractor.

- Raise attachment lift to highest position with attachment lift control.
- Pull freewheel control out and into the slot and release so it is held in the disengaged position.
- Do not push or tow tractor at more than two (2) MPH.
- To reengage transmission, reverse above procedure.

NOTE: To protect hood from damage when transporting your tractor on a truck or a trailer, be sure hood is closed and secured to tractor. Use an appropriate means of tying hood to tractor (rope, cord, etc.).

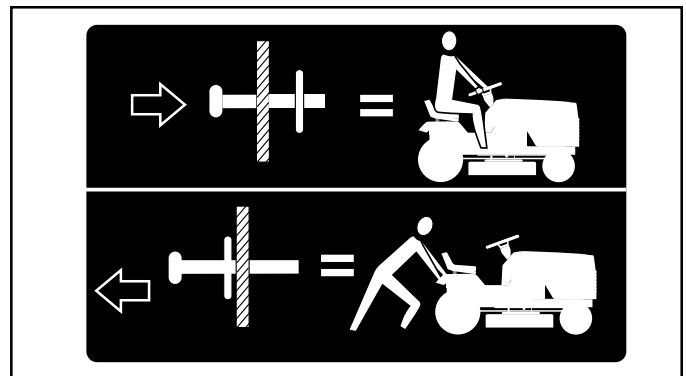

FIG. 11

TOWING CARTS AND OTHER ATTACHMENTS

Tow only the attachments that are recommended by and comply with specifications of the manufacturer of your tractor. Use common sense when towing. Too heavy of a load, while on a slope, is dangerous. Tires can lose traction with the ground and cause you to lose control of your tractor.

OPERATION

BEFORE STARTING THE ENGINE

CHECK ENGINE OIL LEVEL

- The engine in your tractor has been shipped, from the factory, already filled with summer weight oil.
- Check engine oil with tractor on level ground.
- Remove oil fill cap/dipstick and wipe clean, reinsert the dipstick and screw cap tight, wait for a few seconds, remove and read oil level. If necessary, add oil until "FULL" mark on dipstick is reached. Do not overfill.
- For cold weather operation you should change oil for easier starting (See "OIL VISCOSITY CHART" in the Customer Responsibilities section of this manual).
- To change engine oil, see the Customer Responsibilities section in this manual.

ADD GASOLINE

- Fill fuel tank. Use fresh, clean, regular unleaded gasoline with a minimum of 87 octane. (Use of leaded gasoline will increase carbon and lead oxide deposits and reduce valve life). Do not mix oil with gasoline. Purchase fuel in quantities that can be used within 30 days to assure fuel freshness.

IMPORTANT: WHEN OPERATING IN TEMPERATURES BELOW 32°F (0°C), USE FRESH, CLEAN WINTER GRADE GASOLINE TO HELP INSURE GOOD COLD WEATHER STARTING.

⚠ WARNING: Experience indicates that alcohol blended fuels (called gasohol or using ethanol or methanol) can attract moisture which leads to separation and formation of acids during storage. Acidic gas can damage the fuel system of an engine while in storage. To avoid engine problems, the fuel system should be emptied before storage of 30 days or longer. Drain the gas tank, start the engine and let it run until the fuel lines and carburetor are empty. Use fresh fuel next season. See Storage Instructions for additional information. Never use engine or carburetor cleaner products in the fuel tank or permanent damage may occur.



CAUTION: Fill to bottom of gas tank filler neck. Do not overfill. Wipe off any spilled oil or fuel. Do not store, spill or use gasoline near an open flame.

TO START ENGINE (See Fig. 7)

When starting the engine for the first time or if the engine has run out of fuel, it will take extra cranking time to move fuel from the tank to the engine.

- Be sure freewheel control is in the transmission engaged position.
- Sit on seat in operating position, depress brake pedal and set parking brake.
- Move attachment clutch to "DISENGAGED" position.
- Move throttle control to fast position
- Pull choke control out for a cold engine start attempt. For a warm engine start attempt the choke control may not be needed.

NOTE: Before starting, read the warm and cold starting procedures below.

- Insert key into ignition and turn key clockwise to "START" position and release key as soon as engine starts. Do not run starter continuously for more than fifteen seconds per minute. If the engine does not start after several attempts, push choke control in, wait a few minutes and try again. If engine still does not start, pull the choke control out and retry.

WARM WEATHER STARTING (50° F and above)

- When engine starts, slowly push choke control in until the engine begins to run smoothly. If the engine starts to run roughly, pull the choke control out slightly for a few seconds and then continue to push the control in slowly.
- The attachments and ground drive can now be used. If the engine does not accept the load, restart the engine and allow it to warm up for one minute using the choke as described above.

COLD WEATHER STARTING (50° F and below)

- When engine starts, slowly push choke control in until the engine begins to run smoothly. Continue to push the choke control in small steps allowing the engine to accept small changes in speed and load, until the choke control is fully in. If the engine starts to run roughly, pull the choke control out slightly for a few seconds and then continue to push the control in slowly. This may require an engine warm-up period from several seconds to several minutes, depending on the temperature.

NOTE: In extreme cold conditions, if engine will not start, you may need to disengage the motion drive belt as follows:

- Be sure parking brake is engaged.
- Remove retainer spring from the drive belt tension handle to relieve belt tension.
- Start engine and allow it to warm up for three (3) minutes.
- Shut-off engine and engage parking brake.
- Engage drive belt tension handle and replace the retainer spring.

AUTOMATIC TRANSMISSION WARM UP

- Before driving the unit in cold weather, the transmission should be warmed up as follows:
 - Be sure the tractor is on level ground.
 - Place the motion control lever in neutral. Release the parking brake and let the brake slowly return to operating position.
 - Allow one minute for transmission to warm up. This can be done during the engine warm up period.
- The attachments can be used during the engine warm-up period after the transmission has been warmed up and may require the choke control be pulled out slightly.

NOTE: If at a high altitude (above 3000 feet) or in cold temperatures (below 32 F) the carburetor fuel mixture may need to be adjusted for best engine performance. See "TO ADJUST CARBURETOR" in the Service and Adjustments section of this manual.

OPERATION

PURGE TRANSMISSION



CAUTION: Never engage or disengage freewheel lever while the engine is running.

To ensure proper operation and performance, it is recommended that the transmission be purged before operating tractor for the first time. This procedure will remove any trapped air inside the transmission which may have developed during shipping of your tractor.

IMPORTANT: SHOULD YOUR TRANSMISSION REQUIRE REMOVAL FOR SERVICE OR REPLACEMENT, IT SHOULD BE PURGED AFTER REINSTALLATION BEFORE OPERATING THE TRACTOR.

- Place tractor safely on level surface with engine off and parking brake set.
- Disengage transmission by placing freewheel control in freewheeling position (See "TO TRANSPORT" in this section of manual).
- Sitting in the tractor seat, start engine. After the engine is running, move throttle control to slow position. Disengage parking brake
- Move motion control lever to full forward position and hold for five (5) seconds. Move lever to full reverse position and hold for five (5) seconds. Repeat this procedure three (3) times.

NOTE: During this procedure there will be no movement of drive wheels. The air is being removed from hydraulic drive system.

- Move motion control lever to neutral (N) position. Shut-off engine and set parking brake.
- Engage transmission by placing freewheel control in driving position (See "TO TRANSPORT" in this section of manual).
- Sitting in the tractor seat, start engine. After the engine is running, move throttle control to half (1/2) speed. Disengage parking brake.
- Slowly move motion control lever forward, after the tractor moves approximately five (5) feet, slowly move motion control lever to reverse position. After the tractor moves approximately five (5) feet return the motion control lever to the neutral (N) position. Repeat this procedure with the motion control lever three (3) times.
- Your tractor is now purged and now ready for normal operation.

MOWING TIPS

- Tire chains cannot be used when the mower housing is attached to tractor.
- Mower should be properly leveled for best mowing performance. See "TO LEVEL MOWER HOUSING" in the Service and Adjustments section of this manual.
- The left hand side of mower should be used for trimming.
- Drive so that clippings are discharged onto the area that has been cut. Have the cut area to the right of the tractor. This will result in a more even distribution of clippings and more uniform cutting.
- When mowing large areas, start by turning to the right so that clippings will discharge away from shrubs, fences, driveways, etc. After one or two rounds, mow in the opposite direction making left hand turns until finished (See Fig. 12).
- If grass is extremely tall, it should be mowed twice to reduce load and possible fire hazard from dried clippings. Make first cut relatively high; the second to the desired height.
- Do not mow grass when it is wet. Wet grass will plug mower and leave undesirable clumps. Allow grass to dry before mowing.
- **Always operate engine at full throttle when mowing** to assure better mowing performance and proper discharge of material. Regulate ground speed by selecting a low enough gear to give the mower cutting performance as well as the quality of cut desired.
- When operating attachments, select a ground speed that will suit the terrain and give best performance of the attachment being used.

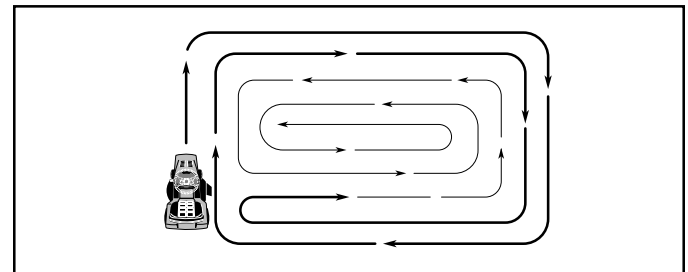

FIG. 12

CUSTOMER RESPONSIBILITIES

TRACTOR

Always observe safety rules when performing any maintenance.

BRAKE OPERATION

If tractor requires more than six (6) feet stopping distance at high speed in highest gear, then brake must be adjusted. (See "TO ADJUST BRAKE" in the Service and Adjustments section of this manual).

TIRES

- Maintain proper air pressure in all tires (See "PRODUCT SPECIFICATIONS" section of this manual).
- Keep tires free of gasoline, oil, or insect control chemicals which can harm rubber.
- Avoid stumps, stones, deep ruts, sharp objects and other hazards that may cause tire damage.

NOTE: To seal tire punctures and prevent flat tires due to slow leaks, tire sealant may be purchased from your local parts dealer. Tire sealant also prevents tire dry rot and corrosion.

OPERATOR PRESENCE SYSTEM

Be sure operator presence and interlock systems are working properly. If your tractor does not function as described, repair the problem immediately.

- The engine should not start unless the brake pedal is fully depressed and attachment clutch control is in the disengaged position.
- When the engine is running, any attempt by the operator to leave the seat without first setting the parking brake should shut off the engine.
- When the engine is running and the attachment clutch is engaged, any attempt by the operator to leave the seat should shut off the engine.
- The attachment clutch should never operate unless the operator is in the seat.

BLADE CARE

For best results mower blades must be kept sharp. Replace bent or damaged blades.

BLADE REMOVAL (See Fig. 13)

- Raise mower to highest position to allow access to blades.
- Remove hex bolt, lock washer and flat washer securing blade.
- Install new or resharpened blade with trailing edge up towards deck as shown.

IMPORTANT: TO ENSURE PROPER ASSEMBLY, CENTER HOLE IN BLADE MUST ALIGN WITH STAR ON MANDREL ASSEMBLY.

- Reassemble hex bolt, lock washer and flat washer in exact order as shown.
- Tighten bolt securely (27-35 Ft. Lbs. torque).

IMPORTANT: BLADE BOLT IS GRADE 8 HEAT TREATED.

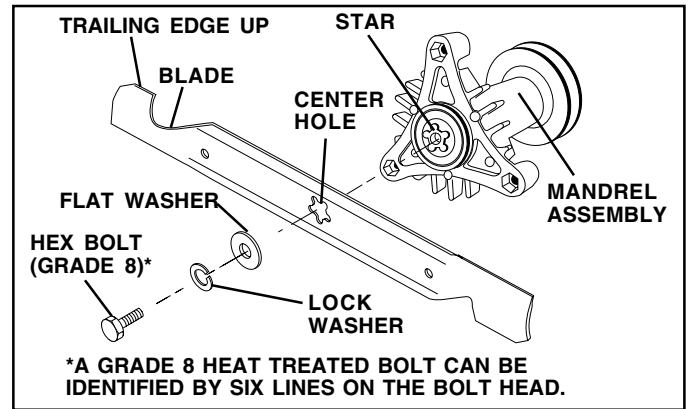

FIG. 13

TO SHARPEN BLADE (See Fig. 14)

NOTE: We do not recommend sharpening blade - but if you do, be sure the blade is balanced.

Care should be taken to keep the blade balanced. An unbalanced blade will cause excessive vibration and eventual damage to mower and engine.

- The blade can be sharpened with a file or on a grinding wheel. Do not attempt to sharpen while on the mower.
- To check blade balance, you will need a 5/8" diameter steel bolt, pin, or a cone balancer. (When using a cone balancer, follow the instructions supplied with balancer).

NOTE: Do not use a nail for balancing blade. The lobes of the center hole may appear to be centered, but are not.

- Slide blade on to an unthreaded portion of the steel bolt or pin and hold the bolt or pin parallel with the ground. If blade is balanced, it should remain in a horizontal position. If either end of the blade moves downward, sharpen the heavy end until the blade is balanced.

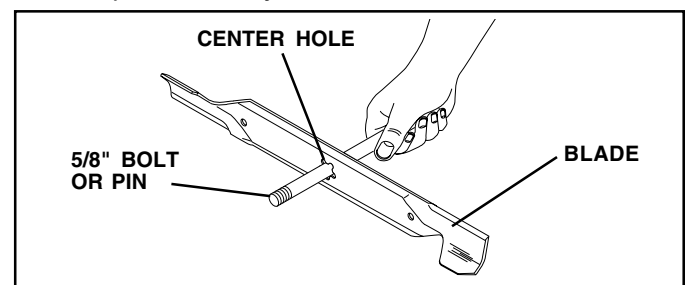

FIG. 14

BATTERY

Your tractor has a battery charging system which is sufficient for normal use. However, periodic charging of the battery with an automotive charger will extend its life.

- Keep battery and terminals clean.
- Keep battery bolts tight.
- Keep small vent holes open.
- Recharge at 6-10 amperes for 1 hour.

NOTE: The original equipment battery on your tractor is maintenance free. Do not attempt to open or remove caps or covers. Adding or checking level of electrolyte is not necessary.

CUSTOMER RESPONSIBILITIES

TO CLEAN BATTERY AND TERMINALS

Corrosion and dirt on the battery and terminals can cause the battery to "leak" power.

- Remove terminal guard.
- Disconnect BLACK battery cable first then RED battery cable and remove battery from tractor.
- Rinse the battery with plain water and dry.
- Clean terminals and battery cable ends with wire brush until bright.
- Coat terminals with grease or petroleum jelly.
- Reinstall battery (See "REPLACING BATTERY" in the SERVICE AND ADJUSTMENTS section of this manual).

V-BELTS

Check V-belts for deterioration and wear after 100 hours of operation and replace if necessary. The belts are not adjustable. Replace belts if they begin to slip from wear.

TRANSAXLE COOLING

The fan and cooling fins of transmission should be kept clean to assure proper cooling.

Do not attempt to clean fan or transmission while engine is running or while the transmission is hot. To prevent possible damage to seals, do not use high pressure water or steam to clean transaxle.

- Inspect cooling fan to be sure fan blades are intact and clean.
- Inspect cooling fins for dirt, grass clippings and other materials. To prevent damage to seals, do not use compressed air or high pressure sprayer to clean cooling fins.

TRANSAXLE PUMP FLUID

The transaxle was sealed at the factory and fluid maintenance is not required for the life of the transaxle. Should the transaxle ever leak or require servicing, contact your nearest authorized service center/department.

ENGINE

LUBRICATION

Only use high quality detergent oil rated with API service classification SF-SJ. Select the oil's SAE viscosity grade according to your expected operating temperature.

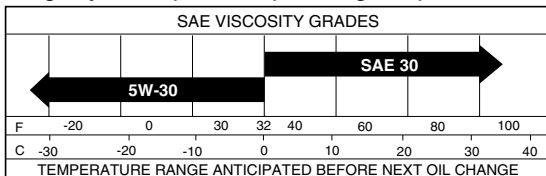

FIG. 15

NOTE: Although multi-viscosity oils (5W30, 10W30 etc.) improve starting in cold weather, these multi-viscosity oils will result in increased oil consumption when used above 32°F. Check your engine oil level more frequently to avoid possible engine damage from running low on oil.

Change the oil after every 50 hours of operation or at least once a year if the tractor is not used for 50 hours in one year.

Check the crankcase oil level before starting the engine and after each eight (8) hours of operation. Tighten oil fill cap/dipstick securely each time you check the oil level.

TO CHANGE ENGINE OIL (See Figs. 15 and 16)

Determine temperature range expected before oil change. All oil must meet API service classification SF-SJ.

- Be sure tractor is on level surface.
- Oil will drain more freely when warm.
- Catch oil in a suitable container.
- Remove oil fill cap/dipstick. Be careful not to allow dirt to enter the engine when changing oil.
- Remove yellow cap from bottom fitting of drain valve and install the drain tube onto the fitting.

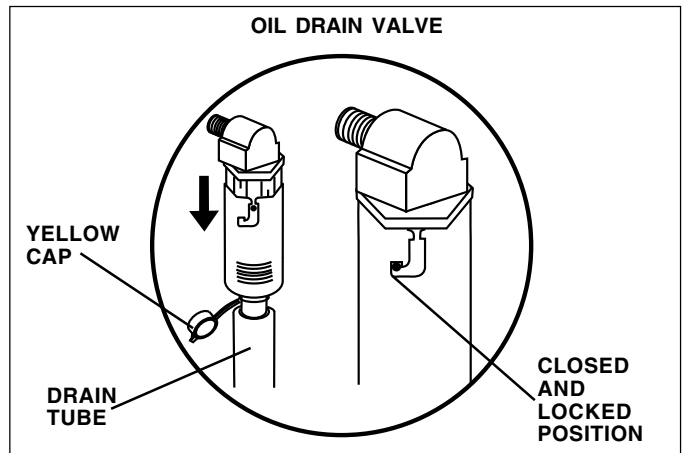

FIG. 16

- Unlock drain valve by pushing inward and turning counterclockwise.
- To open, pull out on the drain valve.
- After oil has drained completely, close and lock the drain valve by pushing inward and turning clockwise until the pin is in the locked position as shown.
- Remove the drain tube and replace the cap onto to the bottom fitting of the drain valve.
- Refill engine with oil through oil fill dipstick tube. Pour slowly. Do not overfill. For approximate capacity see "PRODUCT SPECIFICATIONS" section of this manual.
- Use gauge on oil fill cap/dipstick for checking level. Be sure dipstick cap is tightened securely for accurate reading. Keep oil at "FULL" line on dipstick.

CLEAN AIR SCREEN

Air screen must be kept free of dirt and chaff to prevent engine damage from overheating. Clean with a wire brush or compressed air to remove dirt and stubborn dried gum fibers.

CLEAN AIR INTAKE/COOLING AREAS

To insure proper cooling, make sure the grass screen, cooling fins, and other external surfaces of the engine are kept clean at all times.

Every 100 hours of operation (more often under extremely dusty, dirty conditions), remove the blower housing and other cooling shrouds. Clean the cooling fins and external surfaces as necessary. Make sure the cooling shrouds are reinstalled.

NOTE: Operating the engine with a blocked grass screen, dirty or plugged cooling fins, and/or cooling shrouds removed will cause engine damage due to overheating.

CUSTOMER RESPONSIBILITIES

AIR FILTER (See Fig. 17)

Your engine will not run properly using a dirty air filter. Clean the foam pre-cleaner after every 25 hours of operation or every season. Service paper cartridge every 100 hours of operation or every season, whichever occurs first.

Service air cleaner more often under dusty conditions.

- Remove knobs and cover.

TO SERVICE PRE-CLEANER

- Wash it in liquid detergent and water.
- Squeeze it dry in a clean cloth.
- Saturate it in engine oil. Wrap it in clean, absorbent cloth and squeeze to remove excess oil.
- If very dirty or damaged, replace pre-cleaner.

TO SERVICE CARTRIDGE

- Clean cartridge by tapping gently on flat surface. If very dirty or damaged, replace cartridge.
- Reinstall pre-cleaner cartridge, cover and secure with knobs.

IMPORTANT: PETROLEUM SOLVENTS, SUCH AS KEROSENE, ARE NOT TO BE USED TO CLEAN THE CARTRIDGE. THEY MAY CAUSE DETERIORATION OF THE CARTRIDGE. DO NOT OIL CARTRIDGE. DO NOT USE PRESSURIZED AIR TO CLEAN OR DRY CARTRIDGE.

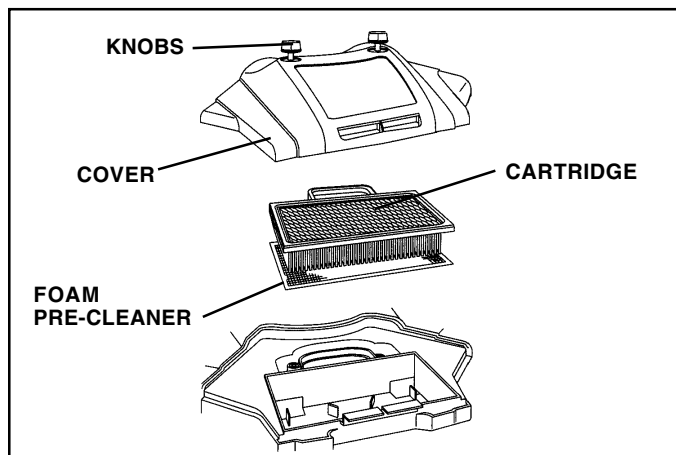

FIG. 17

MUFFLER

Inspect and replace corroded muffler and spark arrester (if equipped) as it could create a fire hazard and/or damage.

SPARK PLUGS

Replace spark plugs at the beginning of each mowing season or after every 100 hours of operation, whichever occurs first. Spark plug type and gap setting are shown in "PRODUCT SPECIFICATIONS" section of this manual.

ENGINE OIL FILTER

Replace the engine oil filter every season or every other oil change if the tractor is used more than 100 hours in one year.

IN-LINE FUEL FILTER (See Fig. 18)

The fuel filter should be replaced once each season. If fuel filter becomes clogged, obstructing fuel flow to carburetor, replacement is required.

- With engine cool, remove filter and plug fuel line sections.
- Place new fuel filter in position in fuel line with arrow pointing towards carburetor.
- Be sure there are no fuel line leaks and clamps are properly positioned.
- Immediately wipe up any spilled gasoline.

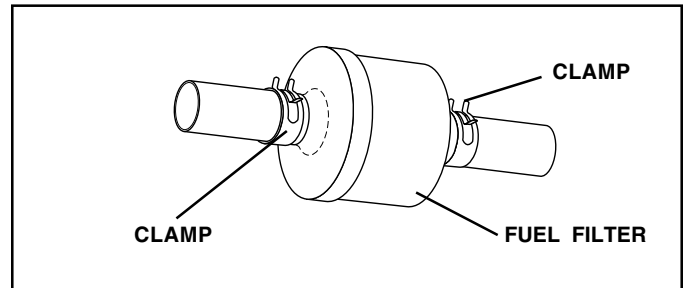

FIG. 18

CLEANING

- Clean engine, battery, seat, finish, etc. of all foreign matter.
- Keep finished surfaces and wheels free of all gasoline, oil, etc.
- Protect painted surfaces with automotive type wax.

We do not recommend using a garden hose to clean your tractor unless the electrical system, muffler, air filter and carburetor are covered to keep water out. Water in engine can result in a shortened engine life.

SERVICE AND ADJUSTMENTS



CAUTION: BEFORE PERFORMING ANY SERVICE OR ADJUSTMENTS:

- Depress brake pedal fully and set parking brake.
- Place attachment clutch in "DISENGAGED" position.
- Turn ignition key "OFF" and remove key.
- Make sure the blades and all moving parts have completely stopped.
- Disconnect spark plug wire from spark plug and place wire where it cannot come in contact with plug.

TRACTOR

TO REMOVE MOWER (See Fig. 19)

- Place attachment clutch in "DISENGAGED" position.
- Turn height adjustment knob to lowest setting.
- Lower mower to its lowest position.
- Remove retainer spring holding anti-swaybar to chassis bracket and disengage anti-swaybar from bracket.
- Remove retainer springs from suspension arms at deck and disengage arms from deck.
- Raise attachment lift to its highest position.
- Remove two retainer springs from each front link and remove links.
- Slide mower forward and remove belt from electric clutch pulley.
- Slide mower out from under right side of tractor.

IMPORTANT: IF AN ATTACHMENT OTHER THAN THE MOWER DECK IS TO BE MOUNTED ON THE TRACTOR, REMOVE THE FRONT LINKS.

TO INSTALL MOWER

Follow procedure described in "INSTALL MOWER AND DRIVE BELT" in the Assembly section of this manual.

TO LEVEL MOWER HOUSING

Adjust the mower while tractor is parked on level ground or driveway. Make sure tires are properly inflated (See "PROD-

UCT SPECIFICATIONS" section of this manual). If tires are over or underinflated, you will not properly adjust your mower.

SIDE-TO-SIDE ADJUSTMENT (See Figs. 19 and 20)

- Raise mower to its highest position.
- Measure height from bottom edge of mower to ground level at front corners of mower. Distance "A" on both sides of mower should be the same.
- If adjustment is necessary, make adjustment on one side of mower only.
- To raise one side of mower, tighten lift link adjustment nut on that side.
- To lower one side of mower, loosen lift link adjustment nut on that side.

NOTE: Each full turn of adjustment nut will change mower height about 3/16".

- Recheck measurements after adjusting.

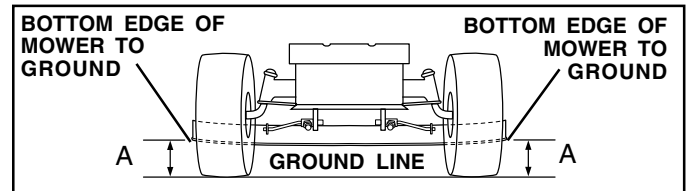

FIG. 20

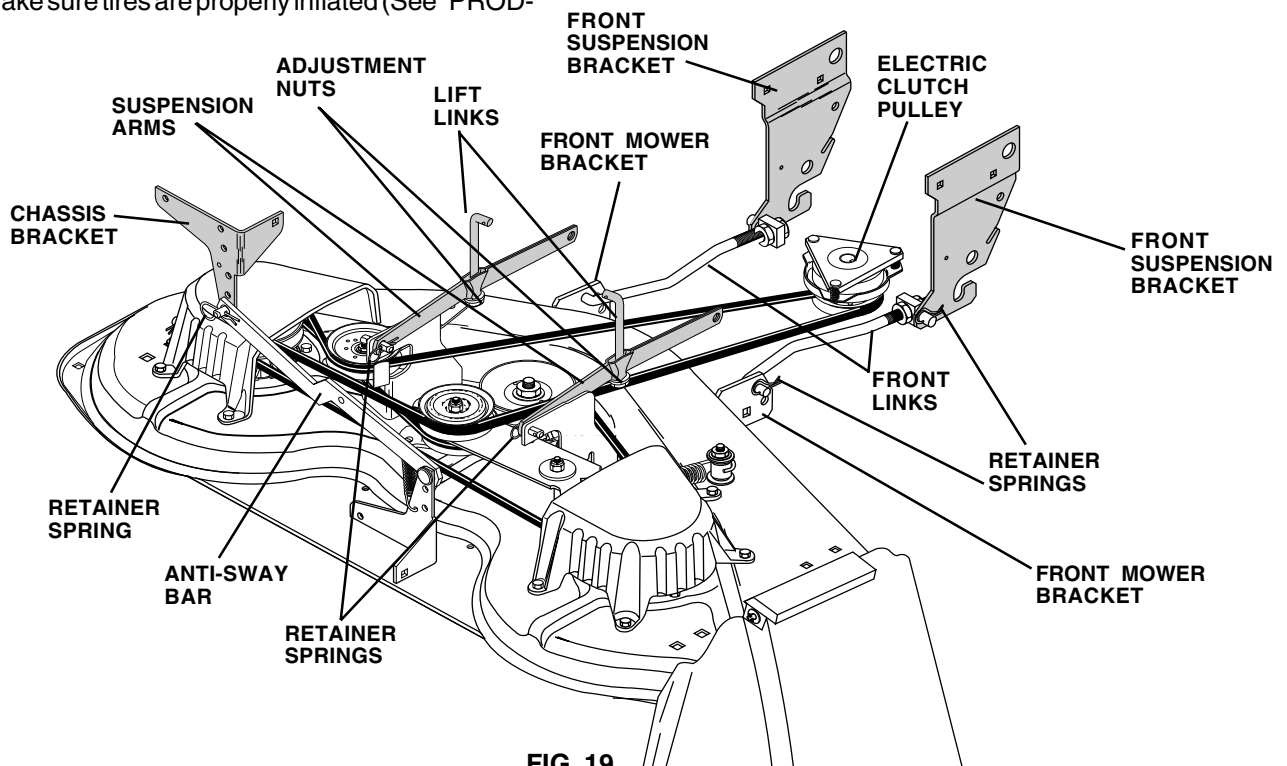

FIG. 19

SERVICE AND ADJUSTMENTS

FRONT-TO-BACK ADJUSTMENT (See Figs. 21 and 22)

IMPORTANT: DECK MUST BE LEVEL SIDE-TO-SIDE. IF THE FOLLOWING FRONT-TO-BACK ADJUSTMENT IS NECESSARY, BE SURE TO ADJUST BOTH FRONT LINKS EQUALLY SO MOWER WILL STAY LEVEL SIDE-TO-SIDE.

To obtain the best cutting results, the mower housing should be adjusted so the front is approximately 1/8" to 1/2" lower than the rear when the mower is in its highest position. Check adjustment on right side of tractor. Measure distance "F" directly in front of and behind the mandrel at bottom edge of mower housing as shown.

- Before making any necessary adjustments, check that both front links are equal in length.
- If links are not equal in length, adjust one link to same length as other link.
- To lower front of mower housing, loosen nut "G" on both front links an equal number of turns.
- When distance "F" is 1/8" to 1/2" lower at front than rear, tighten nut "H" against trunnion on both front links.
- To raise front of mower housing, loosen nut "H" from trunnion on both front links. Tighten nut "G" on both front links an equal number of turns.
- When distance "F" is 1/8" to 1/2" lower at front than rear, tighten nut "H" against trunnion on both front links.

NOTE: Each full turn of nut "G" will change dim. "F" by approximately 3/8".

- Recheck side-to-side adjustment.

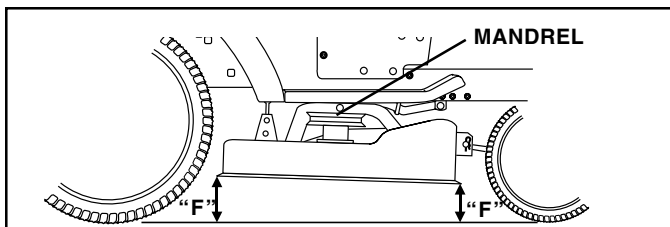

FIG. 21

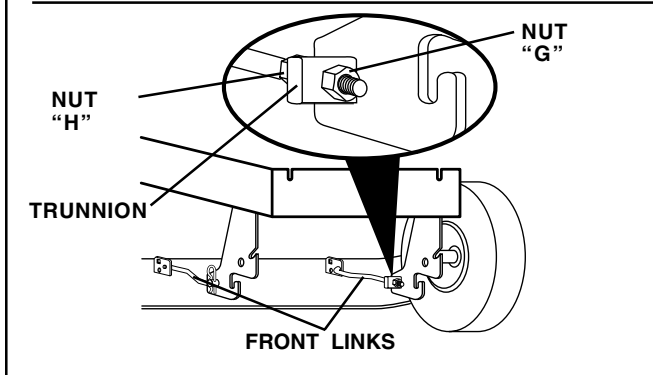
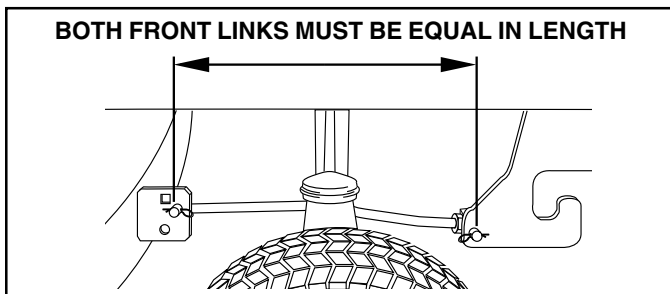

FIG. 22

TO REPLACE MOWER DRIVE BELT

MOWER DRIVE BELT REMOVAL (See Fig. 23)

- Park tractor on a level surface. Engage parking brake.
- Remove screws from L.H. mandrel cover and remove cover.
- Roll belt over the top of L.H. mandrel pulley.
- Remove belt from electric clutch pulley.
- Remove belt from idler pulleys.
- Remove any dirt or grass clippings which may have accumulated around mandrels and entire upper deck surface.
- Check primary idler arm and two idlers to see that they rotate freely.
- Be sure spring is securely hooked to primary idler arm and bolt in mower housing.

MOWER DRIVE BELT INSTALLATION (See Fig. 23)

- Install belt in both idlers. Make sure belt is in both belt keepers at the idlers as shown.
- Install new belt onto electric clutch pulley.
- Roll belt into upper groove of L.H. mandrel pulley.
- Carefully check belt routing making sure belt is in the grooves correctly and inside belt keepers.
- Reassemble L.H. mandrel cover.

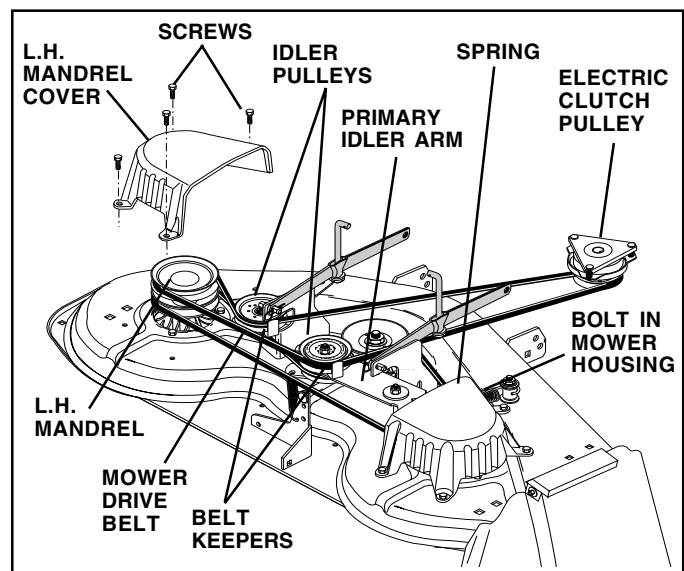

FIG. 23

TO REPLACE MOWER BLADE DRIVE BELT (See Fig. 24)

Park the tractor on level surface. Engage parking brake.

- Remove mower drive belt (See "TO REPLACE MOWER DRIVE BELT" in this section of this manual).
- Remove mower (See "TO REMOVE MOWER" in this section of this manual).
- Remove screws from R.H. mandrel cover and remove cover. Unhook spring from bolt on mower housing.
- Carefully roll belt off R.H. mandrel pulley.
- Remove belt from center mandrel pulley, idler pulley, and L.H. mandrel pulley.
- Remove any dirt or grass which may have accumulated around mandrels and entire upper deck surface.

SERVICE AND ADJUSTMENTS

- Check secondary idler arm and idler to see that they rotate freely.
- Be sure spring is hooked in secondary idler arm and sway-bar bracket.
- Install new belt in lower groove of L.H. mandrel pulley, idler pulley, and center mandrel pulley as shown.
- Roll belt over R.H. mandrel pulley. Make sure belt is in all grooves properly.
- Reconnect spring to bolt in mower housing and reinstall R.H. mandrel cover.
- Reinstall mower to tractor (See "INSTALL MOWER AND DRIVE BELT" in the Assembly section of this manual).
- Reassemble mower drive belt (See "TO REPLACE MOWER DRIVE BELT" in this section of this manual).

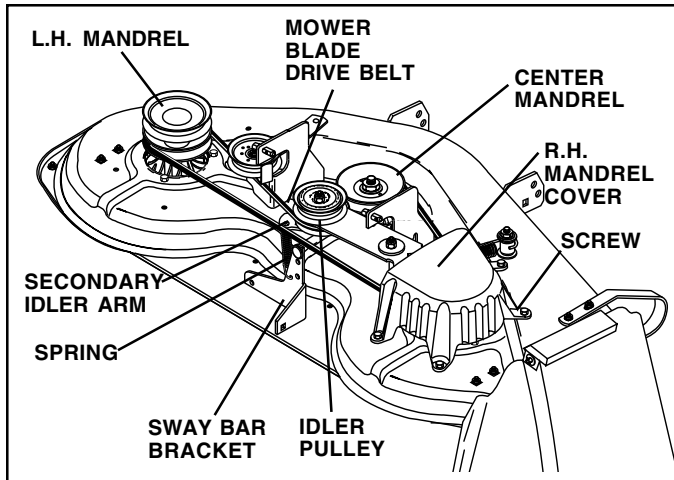

FIG. 24

TO ADJUST ATTACHMENT CLUTCH (See Fig. 25)

The electric clutch should provide years of service. The clutch has a built-in brake that stops the pulley within 5 seconds. Eventually, the internal brake will wear which may cause the mower blades to not engage, or, to not stop as required. Adjustments should be made by your nearest authorized service center/department.

- Make sure attachment clutch and ignition switches are in "OFF" position.
- Adjust the three nylon locknuts until space between clutch plate and rotor measures .012" at all three slot locations cut in side of brake plate.

NOTE: After installing a new electric clutch, run tractor at full throttle and engage and disengage electric clutch 10 cycles to wear in clutch plate.

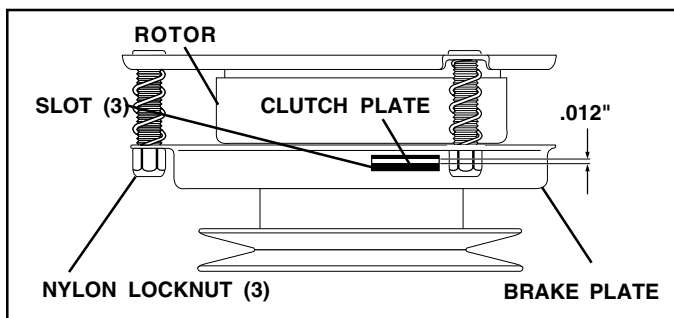

FIG. 25

TO REPLACE MOTION DRIVE BELT (See Fig. 26)

Park the tractor on level surface. Engage parking brake. For ease of service there is a belt installation guide decal on bottom of left footrest.

- Remove mower (See "TO REMOVE MOWER" in this section of this manual.)

BELT REMOVAL -

- Create slack in belt by removing retainer spring from drive belt tension handle.
- Remove belt from all idler pulleys, transaxle pulley and then from engine pulley.

BELT INSTALLATION -

- Install new belt around engine pulley first, then around transaxle pulley and lastly into all the idler pulleys.
- Check to be sure belt is positioned correctly and is on proper side of all belt keepers.
- Engage the drive belt tension handle and replace the retainer spring.
- Reinstall mower.

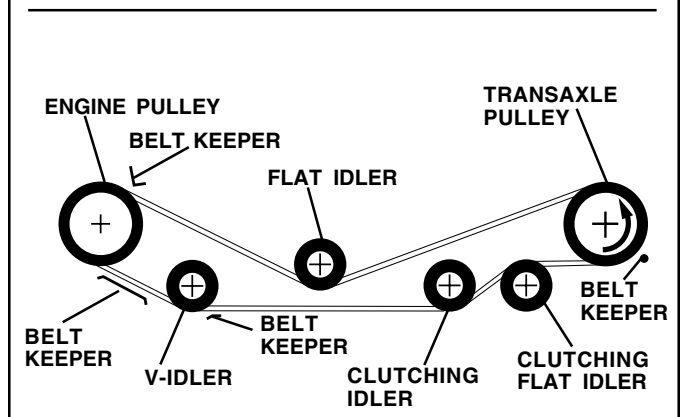
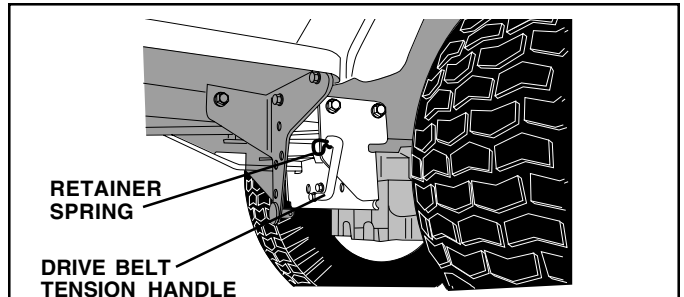

FIG. 26

SERVICE AND ADJUSTMENTS

TRANSAXLE MOTION CONTROL LEVER NEUTRAL ADJUSTMENT (See Fig. 27)

The motion control lever has been preset at the factory and adjustment should not be necessary.

- Park tractor on level surface. Stop tractor by turning ignition key to "OFF" position and engage parking brake.
- Loosen the adjustment bolt in front of the right rear wheel.
- Move motion control lever to the neutral position (N).
- Tighten the adjustment bolt.

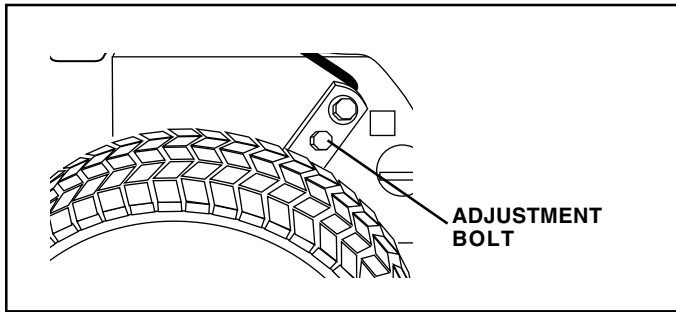

FIG. 27

TRANSMISSION REMOVAL/REPLACEMENT

Should your transmission require removal for service or replacement, it should be purged after reinstallation and before operating the tractor. See "PURGE TRANSMISSION" in the Operation section of this manual.

TO ADJUST STEERING WHEEL ALIGNMENT

If steering wheel crossbars are not horizontal (left to right) when wheels are positioned straight forward, remove steering wheel and reassemble per instructions in the Assembly section of this manual.

FRONT WHEEL TOE-IN ADJUSTMENT

Front wheel toe-in is required for proper steering operation. Toe-in was set at the factory and adjustment should not be necessary. If parts in the front axle or steering mechanism have been replaced or damaged, check toe-in and adjust if necessary.

TO CHECK TOE-IN (See Fig. 28)

- Position front wheels straight ahead.
- Measure distance between wheels at front and rear of tires (dimensions "A" and "B").
- Front dimension "A" should be 1/8" to 1/4" less than rear dimension "B".

TO ADJUST TOE-IN (See Figs. 28 and 19)

- Loosen jam nuts at adjustment sleeves on tie rod.
- Adjust tie rod until dimension "A" is 1/8" to 1/4" less than dimension "B".
- Tighten jam nuts securely.

FRONT WHEEL CAMBER

The front wheel camber is not adjustable on your tractor. If damage has occurred to affect the front wheel camber, contact your nearest authorized service center/department.

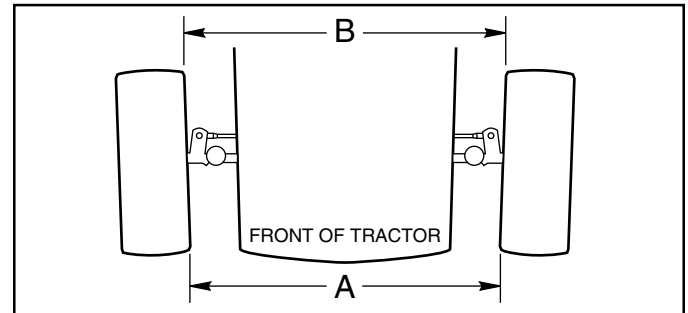

FIG. 28

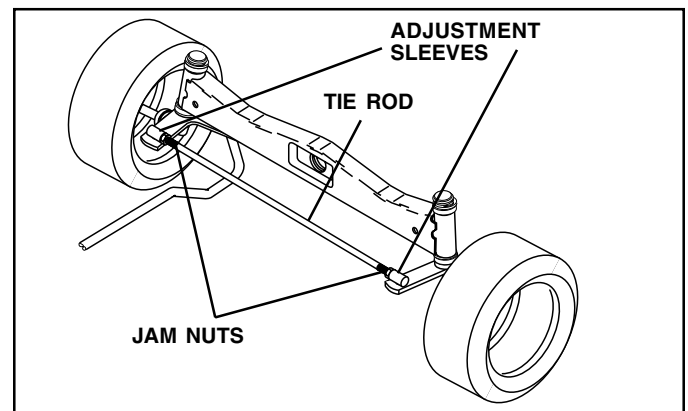

FIG. 29

SERVICE AND ADJUSTMENTS

TO REMOVE WHEEL FOR REPAIRS

FRONT WHEEL (See Fig. 30)

- Block up axle securely.
- Remove axle cover, retaining ring and washers to allow wheel removal.
- Repair tire and reassemble.
- Replace washers and snap retaining ring securely in axle groove.
- Replace axle cover.

REAR WHEEL -

- Block rear axle securely.
- Remove five (5) hub bolts to allow wheel removal.
- Repair tire and reassemble. Replace and tighten hub bolts securely.

NOTE: To seal tire punctures and prevent flat tires due to slow leaks, tire sealant may be purchased from your local parts dealer. Tire sealant also prevents tire dry rot and corrosion.

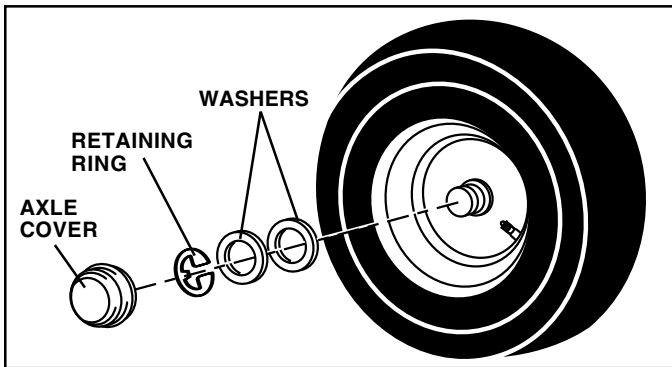

FIG. 30

TO START ENGINE WITH A WEAK BATTERY (See Fig. 31)



CAUTION: Lead-acid batteries generate explosive gases. Keep sparks, flame and smoking materials away from batteries. Always wear eye protection when around batteries.

If your battery is too weak to start the engine, it should be recharged. (See "BATTERY" in the Customer Responsibilities section of this manual).

If "jumper cables" are used for emergency starting, follow this procedure:

IMPORTANT: YOUR TRACTOR IS EQUIPPED WITH A 12 VOLT NEGATIVE GROUND SYSTEM. THE OTHER VEHICLE MUST ALSO BE A 12 VOLT NEGATIVE GROUND SYSTEM. DO NOT USE YOUR TRACTOR BATTERY TO START OTHER VEHICLES.

TO ATTACH JUMPER CABLES -

- Connect each end of the RED cable to the POSITIVE (+) terminal of each battery, taking care not to short against chassis.
- Connect one end of the BLACK cable to the NEGATIVE (-) terminal of fully charged battery.
- Connect the other end of the BLACK cable to good CHASSIS GROUND, away from fuel tank and battery.

TO REMOVE CABLES, REVERSE ORDER -

- BLACK cable first from chassis and then from the fully charged battery.
- RED cable last from both batteries.

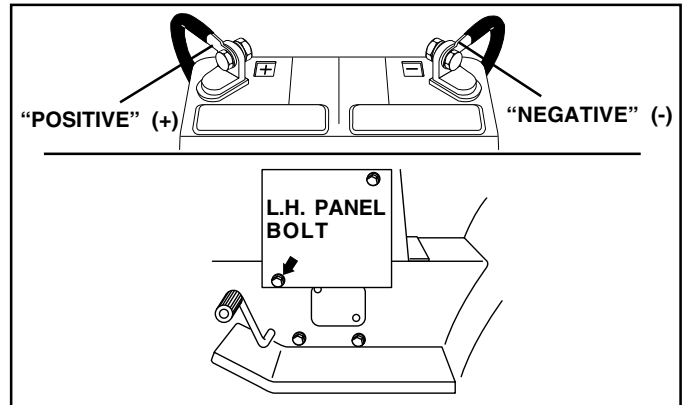

FIG. 31

REPLACING BATTERY (See Fig. 32)



CAUTION: Do not short battery terminals by allowing a wrench or any other object to contact both terminals at the same time. Before connecting battery, remove metal bracelets, wristwatch bands, rings, etc.

Positive terminal must be connected first to prevent sparking from accidental grounding.

- Lift hood to raised position.
- Remove terminal guard.
- Disconnect BLACK battery cable then RED battery cable and carefully remove battery from tractor.
- Install new battery with terminals in same position as old battery.
- Reinstall terminal guard.
- First connect RED battery cable to positive (+) battery terminal with hex bolt and keps nut as shown. Tighten securely.
- Connect BLACK grounding cable to negative (-) battery terminal with remaining hex bolt and keps nut. Tighten securely
- Close terminal access doors.
- Close hood.

SERVICE AND ADJUSTMENTS

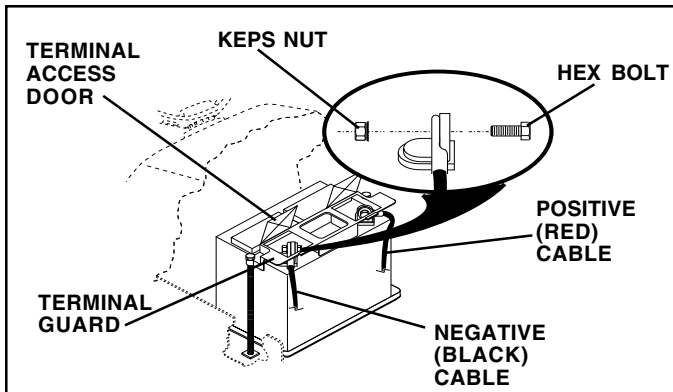

FIG. 32

TO REPLACE HEADLIGHT BULB

- Raise hood.
- Pull bulb holder out of the hole in the backside of the grill.
- Replace bulb in holder and push bulb holder securely back into the hole in the backside of the grill.
- Close hood.

INTERLOCKS AND RELAYS

Loose or damaged wiring may cause your tractor to run poorly, stop running, or prevent it from starting.

- Check wiring. See electrical wiring diagram in the Repair Parts section.

TO REPLACE FUSE

Replace with 30 amp automotive-type plug-in fuse. The fuse holder is located behind the dash.

TO ADJUST ATTACHMENT LIFT SPRING (See Fig. 33)

- While holding spring bushing with wrench, loosen jam nut.
- Turn adjustment bolt clockwise to extend spring and reduce lift effort for heavier attachments.
- Turn adjustment bolt counterclockwise for lighter attachments.
- Retighten jam nut against spring bushing.

IMPORTANT: DO NOT ADJUST FOR MAXIMUM SPRING TENSION WHEN USING LIGHT ATTACHMENTS SUCH AS A MOWER. ADJUST LIFT LEVER SPRING TO AID IN LIFTING ATTACHMENT. DO NOT OVERPOWER SPRING. WHEN REMOVING ATTACHMENT, ALWAYS ADJUST SPRING TENSION TO ITS LOWEST POSITION.

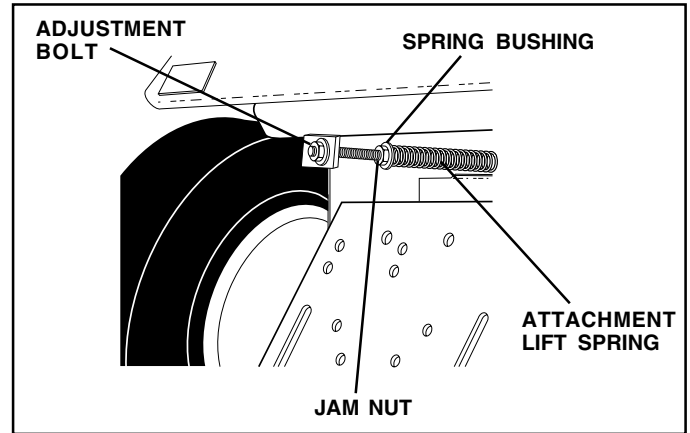

FIG. 33

TO REMOVE HOOD AND GRILL ASSEMBLY (See Fig. 34)

- Raise hood.
- Unsnap headlight wire connector.
- Stand in front of tractor. Grasp hood at sides, tilt toward engine and lift off of tractor.
- To replace, reverse above procedures.

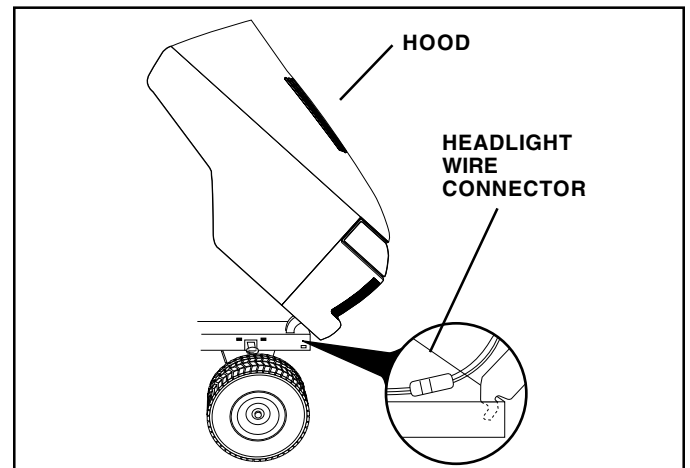

FIG. 34

SERVICE AND ADJUSTMENTS

ENGINE

TO ADJUST THROTTLE CONTROL CABLE (See Fig. 35)

The throttle control has been preset at the factory and adjustment should not be necessary. Check adjustment as described below before loosening cable. If adjustment is necessary, proceed as follows:

- With engine not running, move throttle control lever to fast position.
- Check that swivel is against stop. If it is not, loosen cable clamp screw and pull cable back until swivel is against stop. Tighten cable clamp screw securely.

TO ADJUST CHOKE CONTROL (See Fig. 36)

The choke control has been preset at the factory and adjustment should not be necessary. Check adjustment as described below before loosening cable. If adjustment is necessary, proceed as follows:

- With engine not running, move choke control (located on dash panel) to full choke position.
- Loosen knob and remove cover assembly from air cleaner.
- Choke should be closed. If it is not, loosen casing clamp screw and move choke cable until choke is completely closed. Tighten casing clamp screw securely.
- Replace air cleaner cover assembly and tighten knob.

TO ADJUST CARBURETOR

Your carburetor is not adjustable. If your engine does not operate properly due to suspected carburetor problems, take your tractor to an authorized service center for repair and/or adjustment.

High speed stop is factory adjusted. Do not adjust - damage may result.

IMPORTANT: NEVER TAMPER WITH THE ENGINE GOVERNOR, WHICH IS FACTORY SET FOR PROPER ENGINE SPEED. OVERSPEEDING THE ENGINE ABOVE THE FACTORY HIGH SPEED SETTING CAN BE DANGEROUS. IF YOU THINK THE ENGINE-GOVERNED HIGH SPEED NEEDS ADJUSTING, CONTACT YOUR NEAREST AUTHORIZED SERVICE CENTER/DEPARTMENT, WHICH HAS PROPER EQUIPMENT AND EXPERIENCE TO MAKE ANY NECESSARY ADJUSTMENTS.

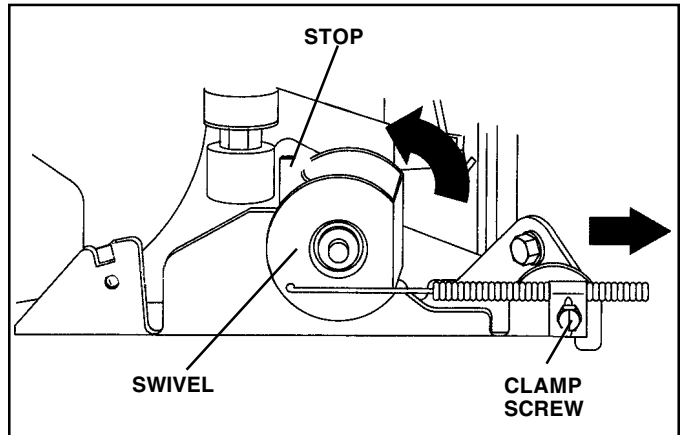

FIG. 35

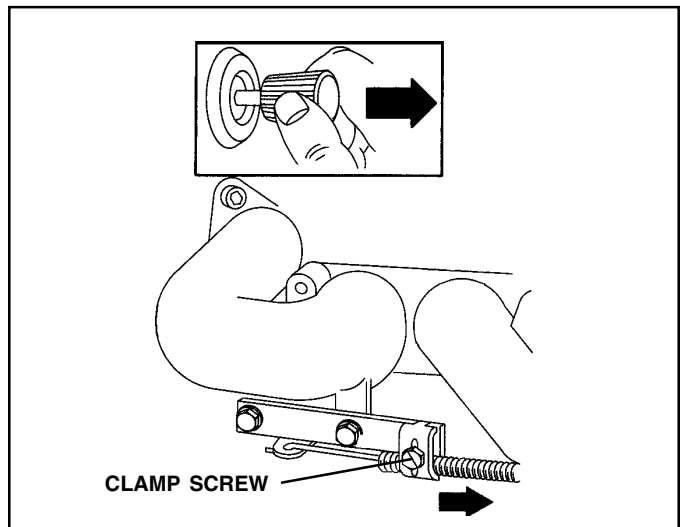

FIG. 36

STORAGE

Immediately prepare your tractor for storage at the end of the season or if the tractor will not be used for 30 days or more.



CAUTION: Never store the tractor with gasoline in the tank inside a building where fumes may reach an open flame or spark. Allow the engine to cool before storing in any enclosure.

TRACTOR

Remove mower from tractor for winter storage. When mower is to be stored for a period of time, clean it thoroughly, remove all dirt, grease, leaves, etc. Store in a clean, dry area.

- Clean entire tractor (See “CLEANING” in the Customer Responsibilities section of this manual).
- Inspect and replace belts, if necessary (See belt replacement instructions in the Service and Adjustments section of this manual).
- Lubricate as shown in the Customer Responsibilities section of this manual.
- Be sure that all nuts, bolts and screws are securely fastened. Inspect moving parts for damage, breakage and wear. Replace if necessary.
- Touch up all rusted or chipped paint surfaces; sand lightly before painting.

BATTERY

- Fully charge the battery for storage.
- After a period of time in storage, battery may require recharging.
- To help prevent corrosion and power leakage during long periods of storage, battery cables should be disconnected and battery cleaned thoroughly (see “TO CLEAN BATTERY AND TERMINALS” in the Customer Responsibilities section of this manual).
- After cleaning, leave cables disconnected and place cables where they cannot come in contact with battery terminals.
- If battery is removed from tractor for storage, do not store battery directly on concrete or damp surfaces.

ENGINE

FUEL SYSTEM

IMPORTANT: IT IS IMPORTANT TO PREVENT GUM DEPOSITS FROM FORMING IN ESSENTIAL FUEL SYSTEM PARTS SUCH AS CARBURETOR, FUEL FILTER, FUEL HOSE, OR TANK DURING STORAGE. ALSO, EXPERIENCE INDICATES THAT ALCOHOL BLENDED FUELS (CALLED GASOHOL OR USING ETHANOL OR METHANOL) CAN ATTRACT MOISTURE WHICH LEADS TO SEPARATION AND FORMATION OF ACIDS DURING STORAGE. ACIDIC GAS CAN DAMAGE THE FUEL SYSTEM OF AN ENGINE WHILE IN STORAGE.

- Drain the fuel tank.
- Start the engine and let it run until the fuel lines and carburetor are empty.
- Never use engine or carburetor cleaner products in the fuel tank or permanent damage may occur.
- Use fresh fuel next season.

NOTE: Fuel stabilizer is an acceptable alternative in minimizing the formation of fuel gum deposits during storage. Add stabilizer to gasoline in fuel tank or storage container. Always follow the mix ratio found on stabilizer container. Run engine at least 10 minutes after adding stabilizer to allow the stabilizer to reach the carburetor. Do not drain the gas tank and carburetor if using fuel stabilizer.

ENGINE OIL

Drain oil (with engine warm) and replace with clean engine oil. (See “ENGINE” in the Customer Responsibilities section of this manual).

CYLINDER(S)

- Remove spark plug(s).
- Pour one ounce of oil through spark plug hole(s) into cylinder(s).
- Turn ignition key to “START” position for a few seconds to distribute oil.
- Replace with new spark plug(s).

OTHER

- Do not store gasoline from one season to another.
- Replace your gasoline can if your can starts to rust. Rust and/or dirt in your gasoline will cause problems.
- If possible, store your tractor indoors and cover it to give protection from dust and dirt.
- Cover your tractor with a suitable protective cover that does not retain moisture. Do not use plastic. Plastic cannot breathe which allows condensation to form and will cause your tractor to rust.

IMPORTANT: NEVER COVER TRACTOR WHILE ENGINE AND EXHAUST AREAS ARE STILL WARM.

TROUBLESHOOTING POINTS

PROBLEM	CAUSE	CORRECTION
Will not start	<ol style="list-style-type: none"> 1. Out of fuel. 2. Engine not "CHOKED" properly. 3. Engine flooded. 4. Bad spark plug. 5. Dirty air filter. 6. Dirty fuel filter. 7. Water in fuel. 8. Loose or damaged wiring. 9. Carburetor out of adjustment. 10. Engine valves out of adjustment. 11. Extreme cold conditions. 	<ol style="list-style-type: none"> 1. Fill fuel tank. 2. See "TO START ENGINE" in Operation section. 3. Wait several minutes before attempting to start. 4. Replace spark plug. 5. Clean/replace air filter. 6. Replace fuel filter. 7. Drain fuel tank and carburetor, refill tank with fresh gasoline and replace fuel filter. 8. Check all wiring. 9. See "To Adjust Carburetor" in Service Adjustments section. 10. Contact an authorized service center/department. 11. See "To start engine" in operation section
Hard to start	<ol style="list-style-type: none"> 1. Dirty air filter. 2. Bad spark plug. 3. Weak or dead battery. 4. Dirty fuel filter. 5. Stale or dirty fuel. 6. Loose or damaged wiring. 7. Carburetor out of adjustment. 8. Engine valves out of adjustment. 	<ol style="list-style-type: none"> 1. Clean/replace air filter. 2. Replace spark plug. 3. Recharge or replace battery. 4. Replace fuel filter. 5. Drain fuel tank and refill with fresh gasoline. 6. Check all wiring. 7. See "To Adjust Carburetor" in Service Adjustments section. 8. Contact an authorized service center/department.
Engine will not turn over	<ol style="list-style-type: none"> 1. Brake pedal not depressed. 2. Attachment clutch is engaged. 3. Weak or dead battery. 4. Blown fuse. 5. Corroded battery terminals. 6. Loose or damaged wiring. 7. Faulty ignition switch. 8. Faulty solenoid or starter. 9. Faulty operator presence switch(es). 	<ol style="list-style-type: none"> 1. Depress brake pedal. 2. Disengage attachment clutch. 3. Recharge or replace battery. 4. Replace fuse. 5. Clean battery terminals. 6. Check all wiring. 7. Check/replace ignition switch. 8. Check/replace solenoid or starter. 9. Contact an authorized service center/department.
Engine clicks but will not start	<ol style="list-style-type: none"> 1. Weak or dead battery. 2. Corroded battery terminals. 3. Loose or damaged wiring. 4. Faulty solenoid or starter. 	<ol style="list-style-type: none"> 1. Recharge or replace battery. 2. Clean battery terminals. 3. Check all wiring. 4. Check/replace solenoid or starter.
Loss of power	<ol style="list-style-type: none"> 1. Cutting too much grass/too fast. 2. Throttle in "CHOKE" position. 3. Build-up of grass, leaves and trash under mower. 4. Dirty air filter. 5. Low oil level/dirty oil. 6. Faulty spark plug. 7. Dirty fuel filter. 8. Stale or dirty fuel. 9. Water in fuel. 10. Spark plug wire loose. 11. Dirty engine air screen/fins. 12. Dirty/clogged muffler. 13. Loose or damaged wiring. 14. Carburetor out of adjustment. 15. Engine valves out of adjustment. 	<ol style="list-style-type: none"> 1. Set in "Higher Cut" position/reduce speed. 2. Adjust throttle control. 3. Clean underside of mower housing. 4. Clean/replace air filter. 5. Check oil level/change oil. 6. Clean and regap or change spark plug. 7. Replace fuel filter. 8. Drain fuel tank and refill with fresh gasoline. 9. Drain fuel tank and carburetor, refill tank with fresh gasoline and replace fuel filter. 10. Connect and tighten spark plug wire. 11. Clean engine air screen/fins. 12. Clean/replace muffler. 13. Check all wiring. 14. See "To Adjust Carburetor" in Service Adjustments section. 15. Contact an authorized service center/department.
Excessive vibration	<ol style="list-style-type: none"> 1. Worn, bent or loose blade. 2. Bent blade mandrel. 3. Loose/damaged part(s). 	<ol style="list-style-type: none"> 1. Replace blade. Tighten blade bolt. 2. Replace blade mandrel. 3. Tighten loose part(s). Replace damaged parts.

TROUBLESHOOTING POINTS

PROBLEM	CAUSE	CORRECTION
Engine continues to run when operator leaves seat with attachment clutch engaged	1. Faulty operator-safety presence control system.	1. Check wiring, switches and connections. If not corrected, contact an authorized service center/department.
Poor cut - uneven	1. Worn, bent or loose blade. 2. Mower deck not level. 3. Buildup of grass, leaves, and trash under mower. 4. Bent blade mandrel. 5. Clogged mower deck vent holes from buildup of grass, leaves, and trash around mandrels.	1. Replace blade. Tighten blade bolt. 2. Level mower deck. 3. Clean underside of mower housing. 4. Replace blade mandrel. 5. Clean around mandrels to open vent holes.
Mower blades will not rotate	1. Obstruction in clutch mechanism. 2. Worn/damaged mower drive belt. 3. Frozen idler pulley. 4. Frozen blade mandrel.	1. Remove obstruction. 2. Replace mower drive belt. 3. Replace idler pulley. 4. Replace blade mandrel.
Poor grass discharge	1. Engine speed too slow. 2. Travel speed too fast. 3. Wet grass. 4. Mower deck not level. 5. Low/uneven tire air pressure. 6. Worn, bent or loose blade. 7. Buildup of grass, leaves and trash under mower. 8. Mower drive belt worn. 9. Blades improperly installed. 10. Improper blades used. 11. Clogged mower deck vent holes from buildup of grass, leaves, and trash around mandrels.	1. Place throttle control in "FAST" position. 2. Shift to slower speed. 3. Allow grass to dry before mowing. 4. Level mower deck. 5. Check tires for proper air pressure. 6. Replace/sharpen blade. Tighten blade bolt. 7. Clean underside of mower housing. 8. Replace mower drive belt. 9. Reinstall blades sharp edge down. 10. Replace with blades listed in this manual. 11. Clean around mandrels to open vent holes.
Headlight(s) not working (if so equipped)	1. Switch is "OFF". 2. Bulb(s) or lamp(s) burned out. 3. Faulty light switch. 4. Loose or damaged wiring. 5. Blown fuse.	1. Turn switch "ON". 2. Replace bulb(s) or lamp(s). 3. Check/replace light switch. 4. Check wiring and connections. 5. Replace fuse.
Battery will not charge	1. Bad battery cell(s). 2. Poor cable connections. 3. Faulty regulator (if so equipped). 4. Faulty alternator.	1. Replace battery. 2. Check/clean all connections. 3. Replace regulator. 4. Replace alternator.
Loss of drive	1. Freewheel control in "disengaged" position. 2. Motion drive belt worn, damaged, or broken. 3. Air trapped in transmission during shipment or servicing.	1. Place freewheel control in "engaged" position. 2. Replace motion drive belt. 3. Purge transmission.
Engine "backfires" when turning engine "OFF"	1. Engine throttle control not set at "SLOW" position for 30 seconds before stopping engine.	1. Move throttle control to "SLOW" position and allow to idle for 30 seconds before stopping engine.

SERVICE NOTES

TRACTOR - - MODEL NUMBER PRGT22H50B

SCHEMATIC

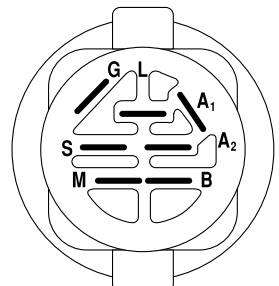
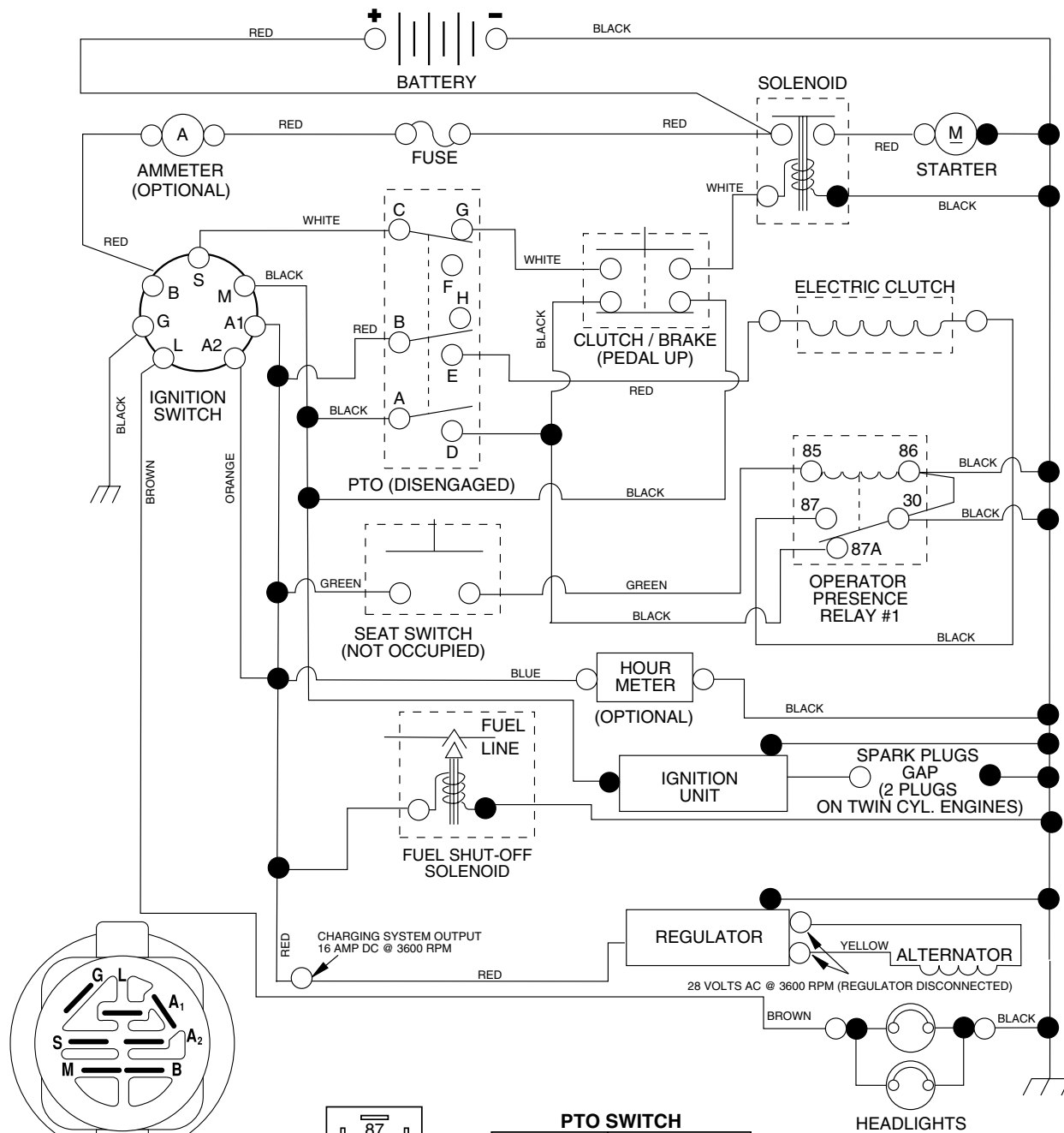

IGNITION SWITCH

POSITION	CIRCUIT	"MAKE"
OFF	M + G + A1	NONE
ON + LIGHTS	B + A1	L + A2
ON	B + A1	NONE
START	B + S + A1	NONE

WIRING INSULATED CLIPS
NOTE: IF WIRING INSULATED CLIPS WERE REMOVED FOR SERVICING OF UNIT, THEY SHOULD BE REPLACED TO PROPERLY SECURE YOUR WIRING.

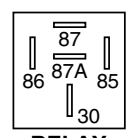

RELAY

PTO SWITCH

POSITION	CIRCUIT
OFF	C + G, B + H
ON	C + F, B + E, A + D

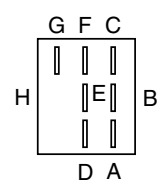

REPAIR PARTS

TRACTOR - - MODEL NUMBER PRGT22H50B

ELECTRICAL

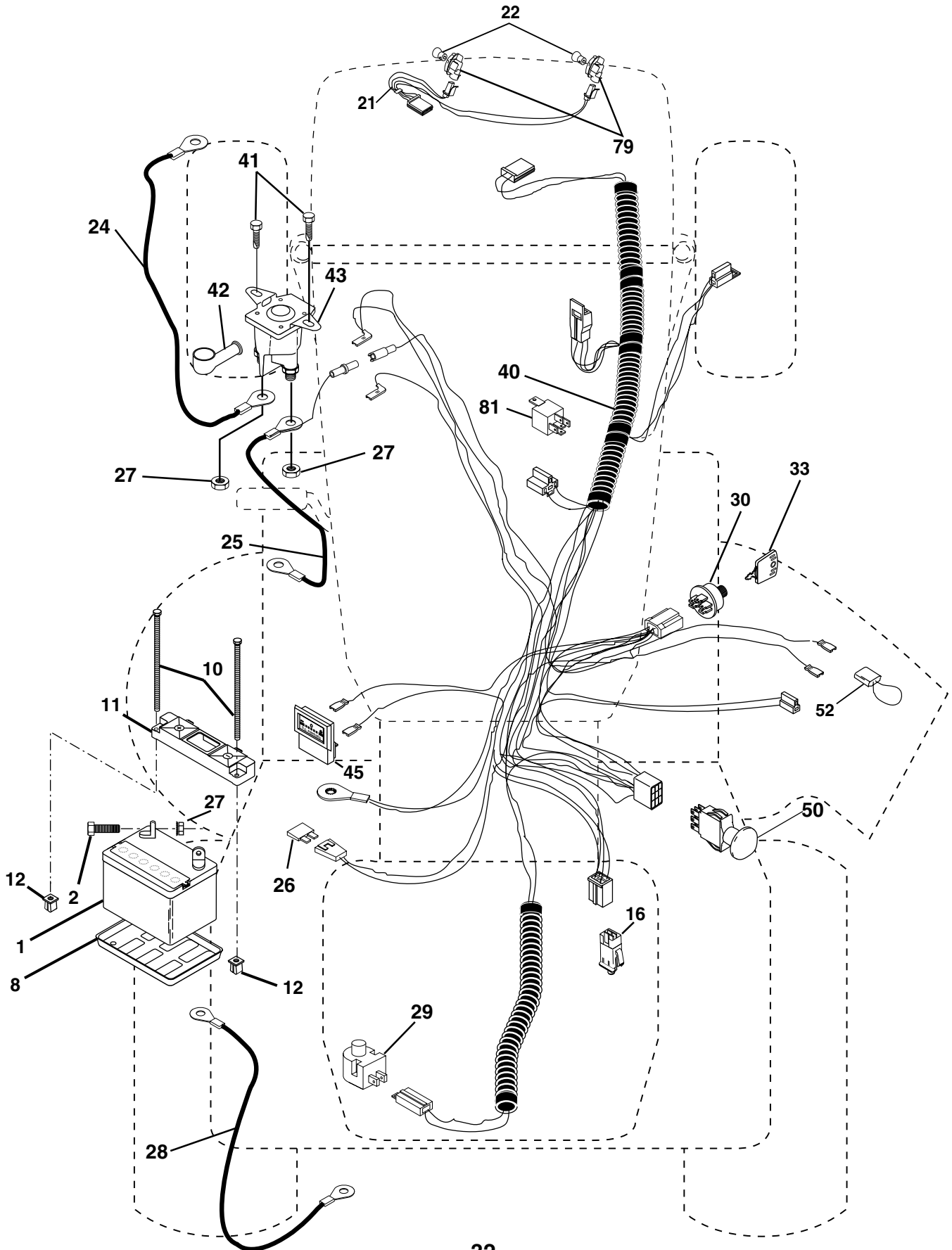

REPAIR PARTS

TRACTOR - - MODEL NUMBER PRGT22H50B

ELECTRICAL

KEY NO.	PART NO.	DESCRIPTION
1	144926	Battery
2	74760412	Bolt Hex Head 1/4-20 x 3/4
8	7603J	Tray, Battery
10	145211	Bolt Btr Frt 1/4-20 X 7.5 zinc
11	150109	Holdown Battery Front Mount
12	145769	Nut Push Nylon 1/4"
16	153664	Switch Interlock Push-In
21	166184	Harness Headlight
22	4152J	Bulb Light
24	4206J	Cable, Battery
25	146149	Cable, Battery
26	108824X	Fuse
27	73510400	Nut Keps Hex 1/4-20 Unc
28	170697	Cable, Ground
29	160784	Switch, Plunger
30	175566	Switch, Ign
33	140401	Key
40	170238	Harness, Ignition
41	17720408	Screw 1/4-20 x 1/2
42	131563	Cover, Terminal Red
43	175141	Solenoid
45	122822X	Ammeter
50	174653	Switch, PTO
52	141940	Protection Wire Loop
79	163996	Socket, Light Bulb
81	109748X	Relay Asm.

NOTE: All component dimensions given in U.S. inches 1 inch = 25.4 mm

REPAIR PARTS

TRACTOR - - MODEL NUMBER PRGT22H50B

CHASSIS AND ENCLOSURES

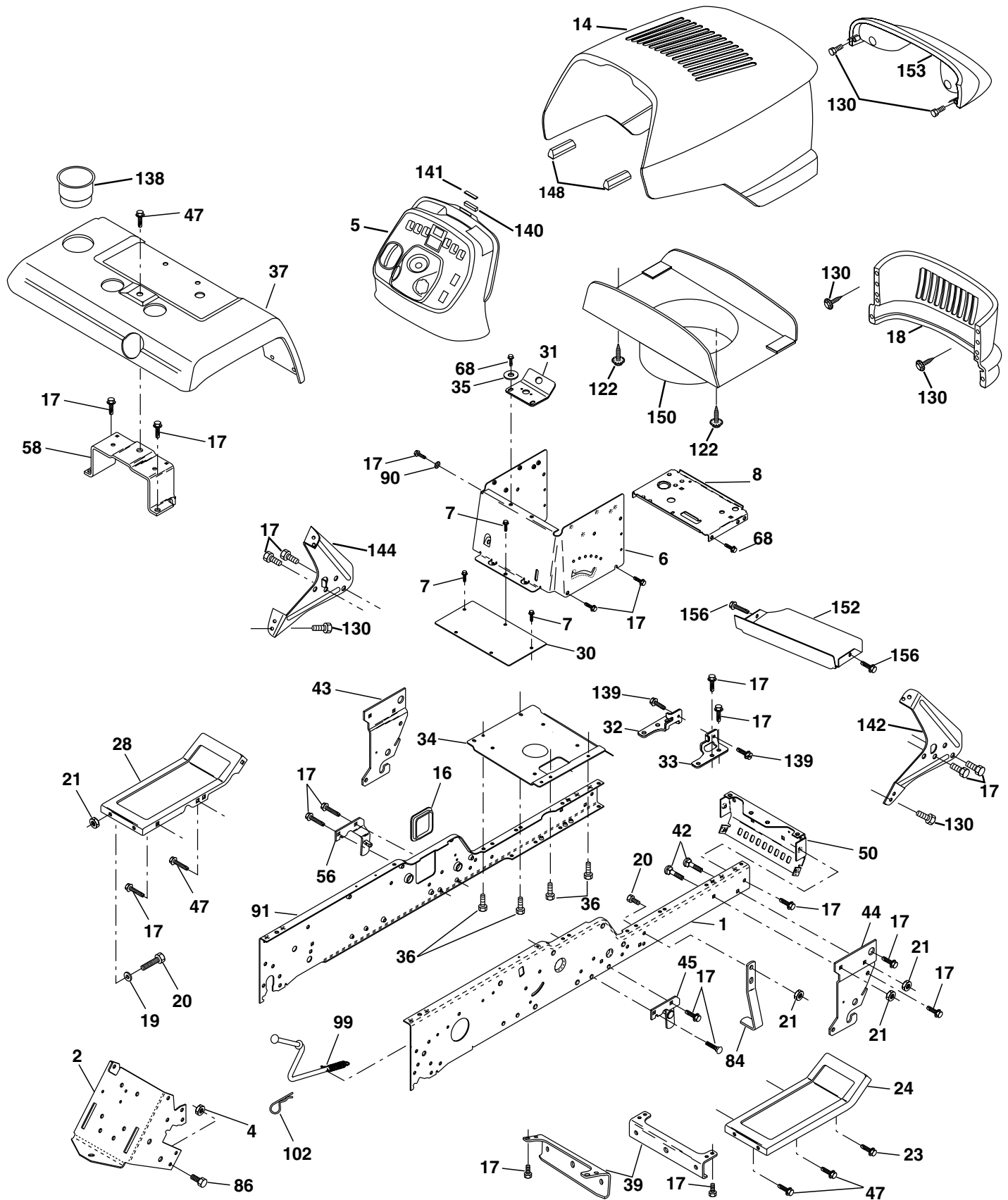

REPAIR PARTS**TRACTOR - - MODEL NUMBER PRGT22H50B****CHASSIS AND ENCLOSURES**

KEY NO.	PART NO.	DESCRIPTION	KEY NO.	PART NO.	DESCRIPTION
1	175465	Rail, Frame RH	47	17670608	Screw Thdrol 3/8-16 x 1/2 TYT
2	175282	Drawbar, Gt	50	175476	Bracket, Chassis Front
4	73680700	Nut, Crownlock 7/16-14Unc	56	154914	Bracket Asm., Susp Chassis Lh
5	163976X428	Dash	58	175315	Bracket Asm., Fender
6	157882	Dash Asm., Lower	68	17490508	Screw, Thd 5/16-18 x 1/2
7	17720408	Screw, Thd Cut 1/4-20 x 1/2	84	142992	Stop, Over Center Mower
8	145166	Support, Battery	86	74760716	Bolt, Fin Hex 7/16-14 Unc x 1
14	175259X428	Hood Asm., Pnt	90	11050600	Washer, Lock External Tooth 3/8
16	121794X	Cover, Access	91	175464	Rail, Frame Lh
17	17060612	Screw, 3/8-16 x 3/4	99	177143	Rod By Pass
18	175289X428	Grille	100	71673	Cap Parking Brake Rod
19	19131312	Washer 13/32 x 13/16 x 12 Ga.	102	4497H	Retainer, Spring
20	74760616	Bolt, Fin Hex 3/8-16 x 1	122	161464	Screw Hex Wshd 8-18 x 7/8
21	73680600	Nut, Crownlock 3/8-16 Unc	130	164863	Screw HWHD Hi-Lo #13-16 x 3/4
23	17060616	Screw 3/8-16 x 1	138	163975X428	Cupholder YTGT
24	145243X428	Footrest, RH	139	171873	Bolt Shoulder 5/16-18 TT
28	145244X428	Footrest, LH	140	163806	Magnet YTGT
30	145052	Saddle, Hydro 1995	141	163805	Stricker Plate YTGT
31	161419	Bracket, Supt 1-pc VGT Steering	142	161897	Bracket Dash RH
32	161327	Bracket, Pivot Chassis LH	143	169847X428	Skirt Grill RH
33	161326	Bracket, Pivot Chassis RH	144	161900	Bracket Dash LH
34	177018	Plate Asm. Engine Chassis	146	169848X428	Skirt Grill LH
35	19111116	Washer 11/32 x 11/16 x 16 Ga.	148	164655	Extrusion Bumper
36	17060512	Screw 5/16-18 x 3/4	150	161237	Duct Heat Hood
37	167287X428	Fender, Pnt.	152	177956	Shield Browning
39	175278	Bracket, Axle Front	153	160568	Lens, Asm Headlight bar
42	72140608	Bolt, Carriage 3/8-16 x 1	156	17060512	Screw 5/16-18 x 3/4
43	136939	Bracket, Spnsn Front Lh			
44	136940	Bracket, Spnsn Front Rh			
45	154913	Bracket Asm., Susp Chassis Rh			

NOTE: All component dimensions given in U.S. inches
1 inch = 25.4 mm

REPAIR PARTS

TRACTOR - - MODEL NUMBER PRGT22H50B

GROUND DRIVE

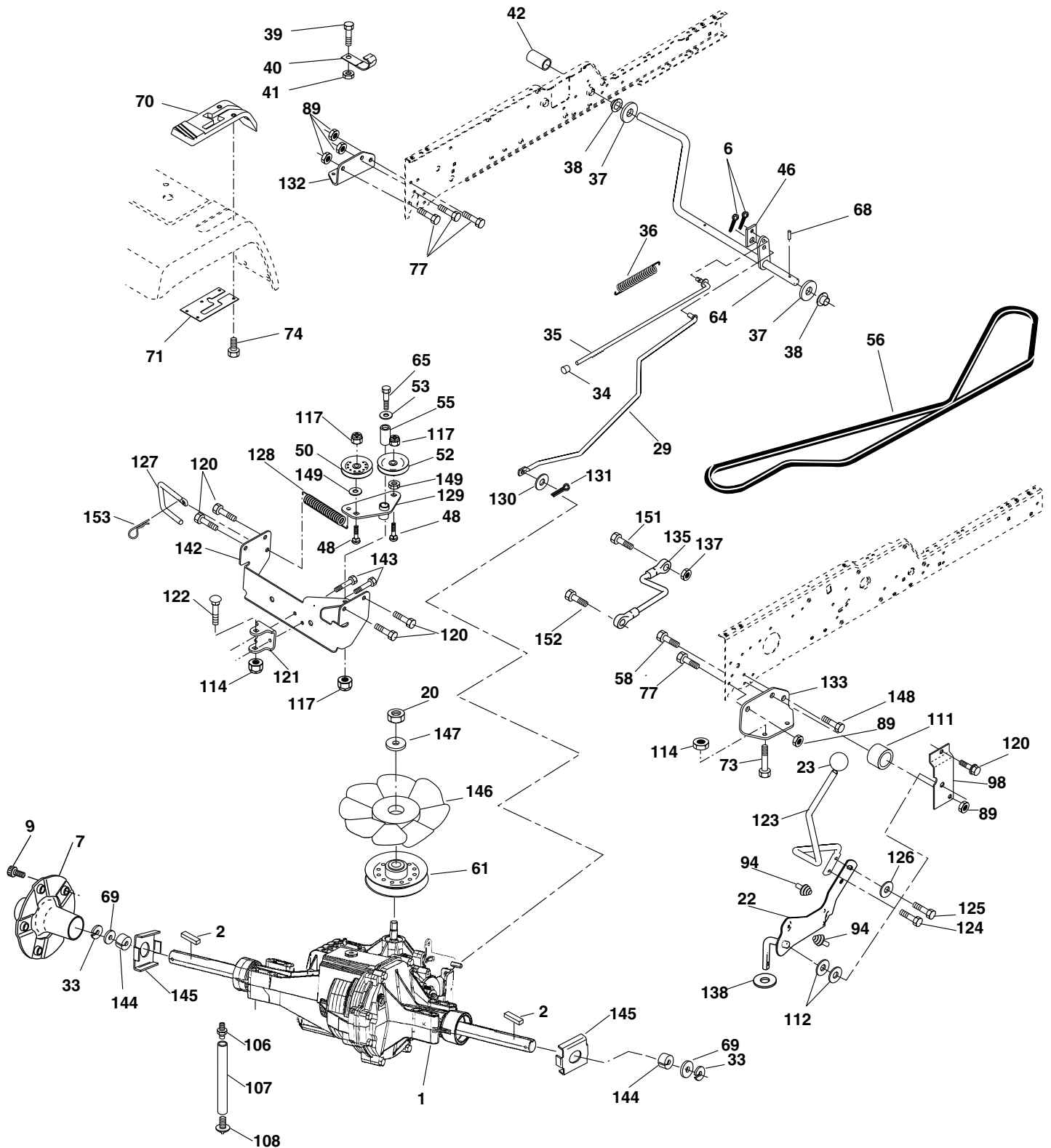

REPAIR PARTS**TRACTOR - - MODEL NUMBER PRGT22H50B****GROUND DRIVE**

KEY NO.	PART NO.	DESCRIPTION	KEY NO.	PART NO.	DESCRIPTION
1	-----	Transaxle Hydro Gear 331-3000 (Order Parts From Transaxle Manufacturer)	106	142918	O-Ring Asm Hydro Gear
2	9396E	Key Sq. 1/4 x 1/4 x 2	107	154739	Line Fuel Hydro 15" VGT
6	76020412	Pin, Cotter	108	142917	Cap Asm Vent Hydro Gear
7	140507	Wheel, Hub Assembly	111	156240	Spacer Shift Lever VGTH
9	140080	Bolt, Hub	112	156104	Washer Nylon High Temp
20	73940800	Nut	114	73800500	Nut Lock Hex W/Ins 5/16-18 Unc
22	178391	Lever Asm Shift	117	73900600	Nut, Lock Flg. 3/8-16
23	140845	Knob	120	17060612	Screw 3/8-16 x .75
29	176600	Brake, Rod	121	175611	Bracket Strap Torque
33	12000053	Ring E	122	72010520	Bolt 5/16-18 x 2.50
34	71673	Cap, Parking Brake	123	176602	Rod Shift
35	137648	Rod, Parking Brake	124	165492	Bolt Shoulder 5/16-18 x .561
36	149412	Spring, Drive Ground	125	166880	Screw 5/16-18 x 5/8
37	121749X	Washer 25/32 x 1-1/4 x 16 Ga.	126	166002	Washer SRRTD 5/16 ID x 1.0 x .125
38	150035	Nyliner	127	177362	Link Control Clutch
39	74321016	Screw, Fin. #10-24 x 1	128	176624	Spring Drive GRND
40	5304J	Actuator, Interlock Switch	129	178588	Bracket Asm Idler Tensioning
41	73931000	Nut Centerlock 10-24 Unc	130	19131016	Washer 13/32 x 5/8 x 16 Ga.
42	123533X	Cover, Pedal	131	76020308	Pin Cotter 3/32 x 1/2
46	145170	Retainer, Spring	132	175467	Bracket Mtg Hydro 3500 LH VGT
48	72110614	Bolt Rdhd 3/8-16 x 1-3/4 Gr. 5	133	175468	Bracket Mtg Hydro 3500 RH VGT
50	131494	Pulley, Idler, Flat	134	176623	Arm Shift Hydro 3500
52	127783	Pulley, Idler, Grooved	135	177364	Link Asm Control Hydro 3500
53	207J	Washer, Hardened	136	1685H	Nut Lock 5/16-18 NC Thd.
55	105706X	Bearing, Idler	137	74780516	Bolt Fin Hex 5/16-18 Unc x 1.00
56	161597	V-Belt	138	1370H	Washer Thrust 5/8 x 1.10 x 1/32
58	74760724	Bolt Fin Hex 7/16-14 x 1-1/2	139	74550412	Bolt 1/4-28 Unf Gr8 w/Patch
61	143995	Pulley, Transaxle	140	10040400	Washer Lock Hvy. Helical 1/4
64	176601	Shaft, Brake Pedal	141	19091210	Washer 9/32 x 3/4 x 10 Ga.
65	67609	Bolt, Shoulder	142	175469	Strap Torque HG-3500
68	5142H	Pin, Roll	143	17060512	Screw 5/16-18 x 3/4
69	123800	Washer	144	160849	Washer Spacer Axle HG-3000
70	164892X428	Console Shift	145	163168	Washer Axle Flange HG-3000
71	151179	Plate Console Shift	146	140462	Fan 7" Hydro
73	74490548	Bolt Hex Flghd 5/16-18 x 3 Gr5	147	141322	Washer
74	142432	Screw Hex Wsh. Hi-Lo 1/4-1/2	148	17060616	Screw 3/8-16 x 1.0
77	74760716	Bolt Fin Hex 7/16-14 x 1	149	19131410	Washer 13/32 x 7/8 x 10 Ga.
89	73680700	Nut Crownlock 7/16-14 Unc	153	4497H	Spring, Retainer
94	133835	Fastener Christmas Tree			
98	141004	Bracket Shift			

NOTE: All component dimensions given in U.S. inches
1 inch = 25.4 mm

REPAIR PARTS

TRACTOR - - MODEL NUMBER PRGT22H50B

STEERING ASSEMBLY

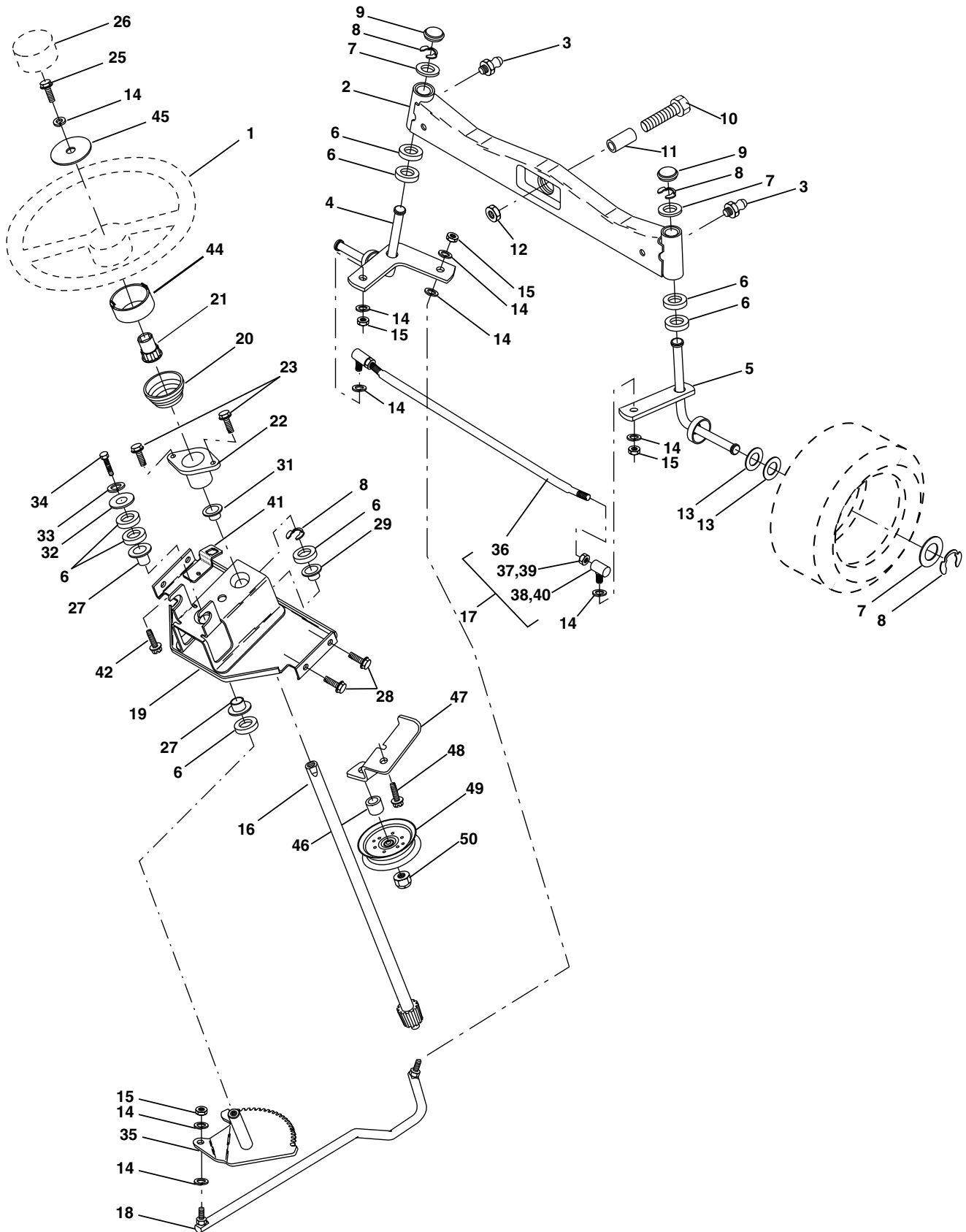

REPAIR PARTS**TRACTOR - - MODEL NUMBER PRGT22H50B****STEERING ASSEMBLY**

KEY NO.	PART NO.	DESCRIPTION
1	159944X428	Wheel, Steering
2	137094	Axle Asm., Front
3	6855M	Fitting, Grease
4	161849	Spindle Asm, LH
5	161848	Spindle Asm., RH
6	6266H	Bearing, Race Thrust Harden
7	121748X	Washer 25/32 x 1-5/8 x 16 Ga.
8	12000029	Ring, Klip #T5304-75
9	121232X	Cap, Spindle
10	74781044	Bolt, Fin Hex 5/8-11 x 2-3/4
11	136518	Spacer, Brg. Axle Front
12	73901000	Nut, Lock Flange 5/8-11 Unc
13	121749X	Washer 25/32 x 1-1/4 x 16 Ga.
14	10040600	Washer, Lock Hvy Hlcl Spr 3/8
15	7810H	Nut Lock Center 3/8-24 Unf
16	145103	Shaft Asm., Steering
17	137347	Rd Asm. Tie Ball
18	137155	Draglink, Ball Joint Solid Vgt
19	156011	Support Asm., Steering Vgt
20	163887X428	Boot Steering Stealth
21	159945	Adapter, Wheel Steering
22	155105	Bushing, Strg.
23	152927	Screw
25	74780616	Bolt, Fin Hex 3/8-16 x 1 Gr. 5
26	159946X428	Insert Cap Strg WH
27	3366R	Bearing, Col. Strg.
28	17000612	Screw Hexwsh thdr 3/8-16 x 3/4
29	104239X	Bearing, Flange
31	138136	Bushing, Nyliner Snap
32	19111610	Washer 11/32 x 1 x 10 Ga.
33	10040500	Washer, Lock Hvy Hlcl Spr 5/16
34	74780512	Bolt, Hex Hd 5/16-18 x 3/4
35	138059	Gear, Sector Steering
36	137156	Tie Rod
37	73360600	Nut Hex Jam 3/8-24 Unf
38	109850X	Joint Asm. Ball RH Service
39	73700600	Nut Hex Jam 3/8-24 Unf LH
40	109851X	Joint Asm. Ball LH Service
41	155246	Bracket Switch Interlock Vgt 97
42	17490508	Screw Thdrol 5/16-18 x 1/2 Tyt
44	160135X428	Extension Steering
45	19132411	Washer 13/32 x 1-1/2 x 11 Ga.
46	178291	Spacer
47	177863	Bracket Asm. Idler Stationary
48	17060612	Screw 3/8-16 x .75
49	131494	Pulley Idler Flat
50	73900600	Nut Lock Flg. 3/8-16 Unc

NOTE: All component dimensions given in U.S. inches
1 inch = 25.4 mm

REPAIR PARTS

TRACTOR - - MODEL NUMBER PRGT22H50B

ENGINE

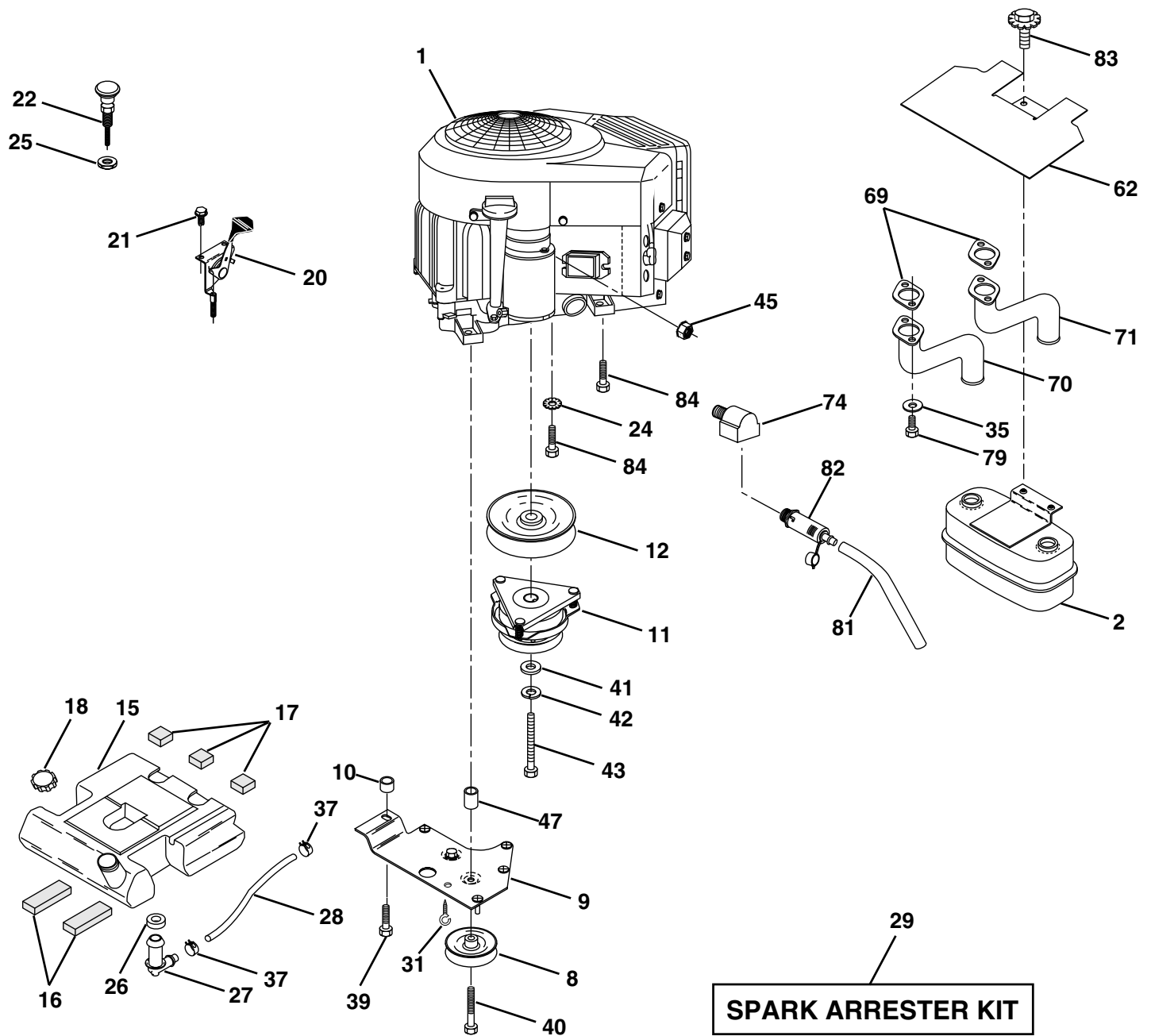

REPAIR PARTS**TRACTOR - - MODEL NUMBER PRGT22H50B****ENGINE**

KEY NO.	PART NO.	DESCRIPTION
1	-----	Engine Briggs, Model No. 407777 (Order parts from engine manuf.)
2	149723	Muffler Side
8	121361X	Pulley V-Idler
9	177748	Keeper Asm. Belt Engine VGT
10	175287	Bushing
11	170056	Clutch Electric
12	143996	Pulley Engine VGT Elect Clutch
15	151346	Tank Fuel Rear 3.50
16	109227X	Pad Spacer
17	106082X	Pad Spacer
18	140527	Top Vented N/LANY
20	175437X428	Control Throttle
21	164863	Screw Hex Thd Cut 1/4 - 20 X 5/8
22	175440X428	Control Choke
24	11050600	Washer Ext Tooth 3/8
25	73920600	Nut Keps 3/8-24 Unf
26	3645J	Bushing
27	139277	Stem Tank Fuel
28	7834R	Fuel Line
29	137180	Spark Arrester Kit
35	10040500	Washer
37	123487X	Clamp Hose
39	17490636	Screw TT 3/8-16 x 2-1/4 UNC
40	17490664	Screw TT 3/8-16 x 4 UNC
41	126197X	Washer 1-1/2 OD X 15/32 ID X .250
42	10040700	Washer Lock 7/16
43	173937	Bolt Hex 7/16-20 X 4 Gr. 5
45	73510400	Nut Keps Hex 1/4-20
47	175288	Spacer
62	146629	Shield Heat Muffler CV-Intek
69	165391	Gasket
70	176069	Tube Exhaust LH
71	176070	Tube Exhaust RH
74	162295	Elbow Street Brass
79	71070512	Screw Hex Hd Cap 5/16-18 x 3/4
81	148456	Tube Drain Oil Easy
82	148315	Plug Oil Drain Easy
83	171877	Bolt 5/16-18unc X 1-3/4 W/Sems
84	17490624	Screw Thdrol 3/8-16 x 1-1/2

NOTE: All component dimensions given in U.S. inches
1 inch = 25.4 mm

REPAIR PARTS

TRACTOR - - MODEL NUMBER PRGT22H50B

SEAT ASSEMBLY

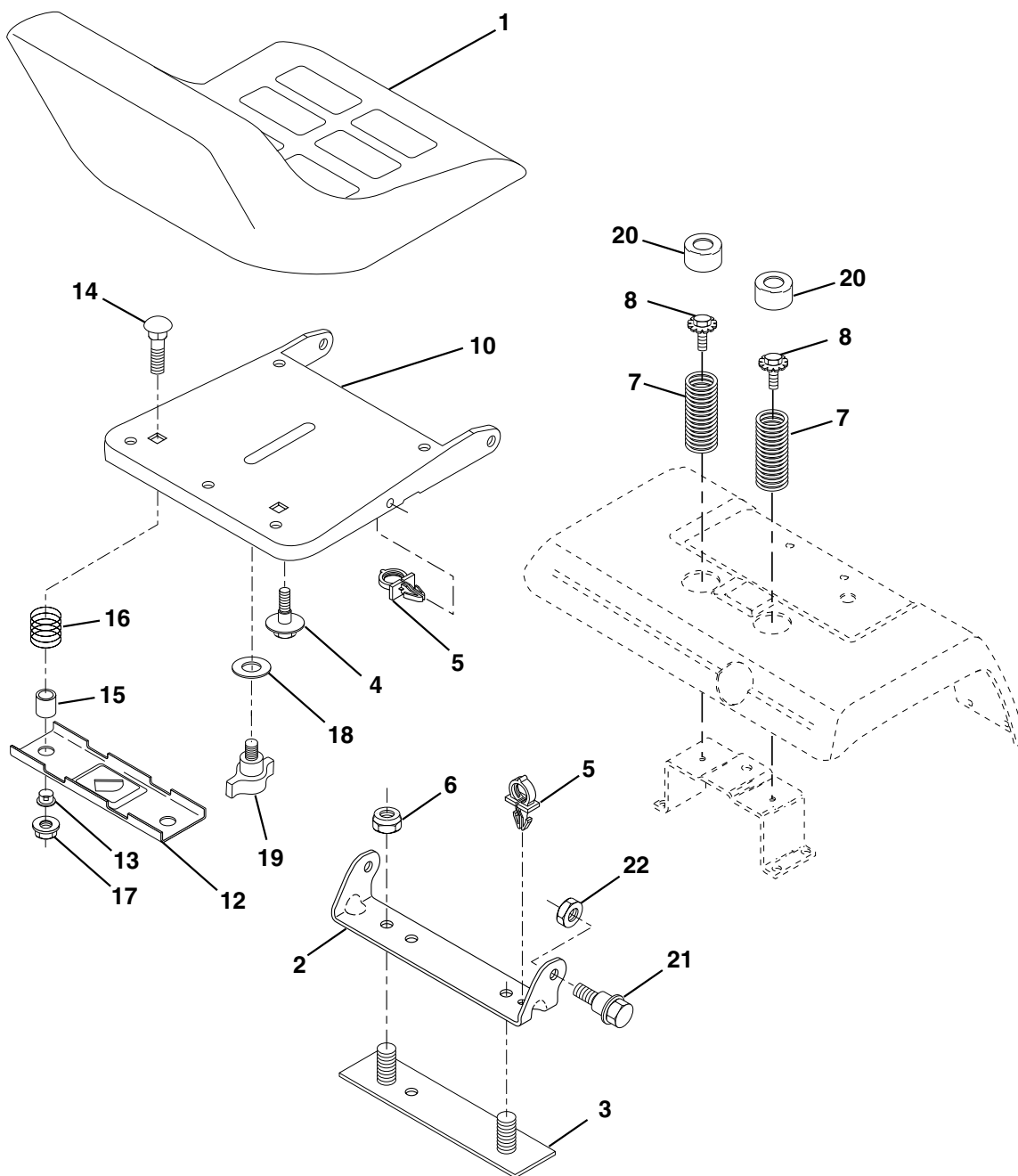

KEY NO.	PART NO.	DESCRIPTION
1	173818	Seat
2	140551	Bracket, Pivot Seat
3	140675	Strap, Fender Asm.
4	127018X	Bolt, Shoulder 5/16-18 x .62
5	145006	Clip, Push-In Hinged
6	73800600	Nut, Crownlock 3/8-16
7	124181X	Spring, Seat Cprsn.
8	171877	Bolt 5/16-18 UNC x 3/4 w/Sems
10	174894	Pan, Seat
12	121246X	Bracket, Mounting Switch
13	121248X	Bushing, Snap
14	72050412	Bolt, Carriage 1/4-20 x 1-1/2

KEY NO.	PART NO.	DESCRIPTION
15	121249X	Spacer, Split
16	123740X	Spring, Cprsn.
17	123976X	Nut, Lock 1/4 Lg. Flg. Gr. 5
18	19171912	Washer 17/32 x 1-3/16 x 12 Ga.
19	166369	Knob, Seat
20	124238X	Cap, Spring Seat Blk
21	171852	Bolt 5/16-18 Unc-2A
22	73800500	Nut, Crownlock 5/16-18

NOTE: All component dimensions given in U.S. inches
1 inch = 25.4 mm

REPAIR PARTS

TRACTOR - - MODEL NUMBER PRGT22H50B

LIFT ASSEMBLY

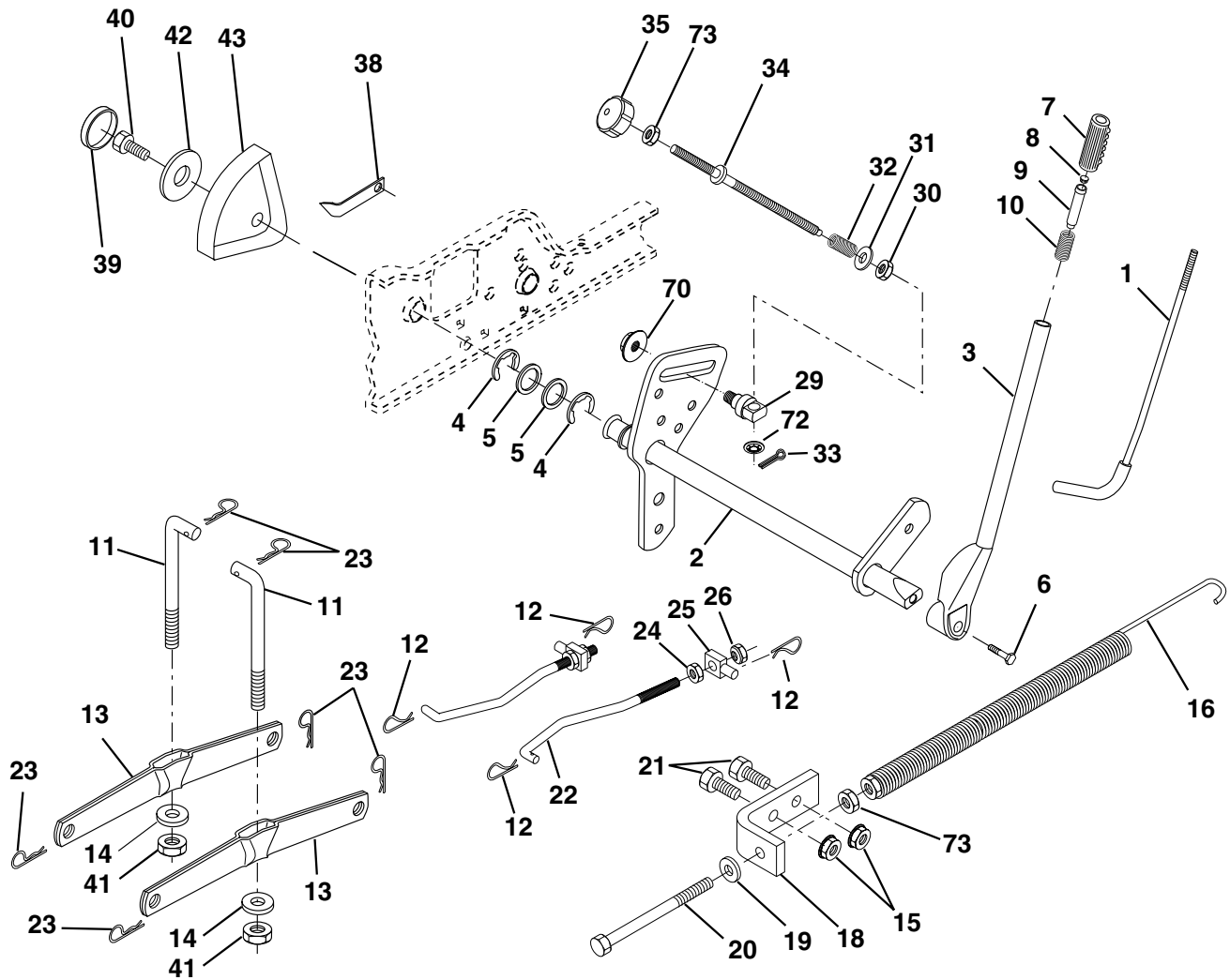

KEY NO.	PART NO.	DESCRIPTION	KEY NO.	PART NO.	DESCRIPTION
1	121006X	Rod Asm., Lever	23	4939M	Retainer, Spring
2	159187	Shaft Asm., Lift Vgt	24	73350800	Nut, Jam Hex 1/2-13 Unc
3	159189	Lever Asm., Lift Rh	25	130171	Trunnion
4	12000022	E-Ring Truarc #5133-87	26	73680800	Nut, Crownlock 1/2-13 Unc
5	19292016	Washer 29/32 x 1-1/4 x 16 Ga.	29	150233	Trunnion Inf. Height
6	71110624	Bolt, Fin Hex 3/8-16 x 1-1/2	30	110807X	Nut, Special
7	125631X	Grip, Handle Fluted	31	19131016	Washer 13/32 x 5/8 x 16 Ga.
8	170770	Button, Plunger	32	137150	Spring, Compression Inf Hgt
9	122364X	Plunger, Lever Lift	33	76020308	Pin, Cotter 3/32 x 1/2
10	2876H	Spring 2-1/8"	34	137167	Rod, Adj Lift
11	146704	Link Lift	35	138057	Knob, Inf 3/8-16 Unc
12	163552	Retainer, Spring	38	155097	Pointer, Height Indicator
13	139868	Arm, Suspension Vgt	39	123935X	Plug, Hole
14	169865	Bearing Pivot Lift Tapered	40	17060516	Screw 5/16-18 x 3/4
15	73350600	Nut, Crownlock 3/8-16 Unc	41	73540600	Nut, Crownlock 3/8-24
16	674A247	Spring Asm., Assist Lift	42	19112410	Washer 11/32 x 1-1/2 x 10 Ga.
17	73680600	Nut, Hex Jam 3/8-16 Unc	43	123934X	Scale, Indicator Height
18	143363	Bracket, Spring Assist	70	145212	Nut, Hexflange Lock
19	19131316	Washer 13/32 x 13/16 x 16 Ga.	72	110452X	Nut, Push Phos & Oil
20	5328J	Bolt, Adjust Spring Assist	73	73350600	Nut Hex Jam 3/8-16 Unc
21	74760616	Bolt, Fin Hex 3/8-16 x 1			
22	127218	Link, Front			

NOTE: All component dimensions given in U.S. inches
1 inch = 25.4 mm

REPAIR PARTS

TRACTOR - - MODEL NUMBER PRGT22H50B

MOWER DECK

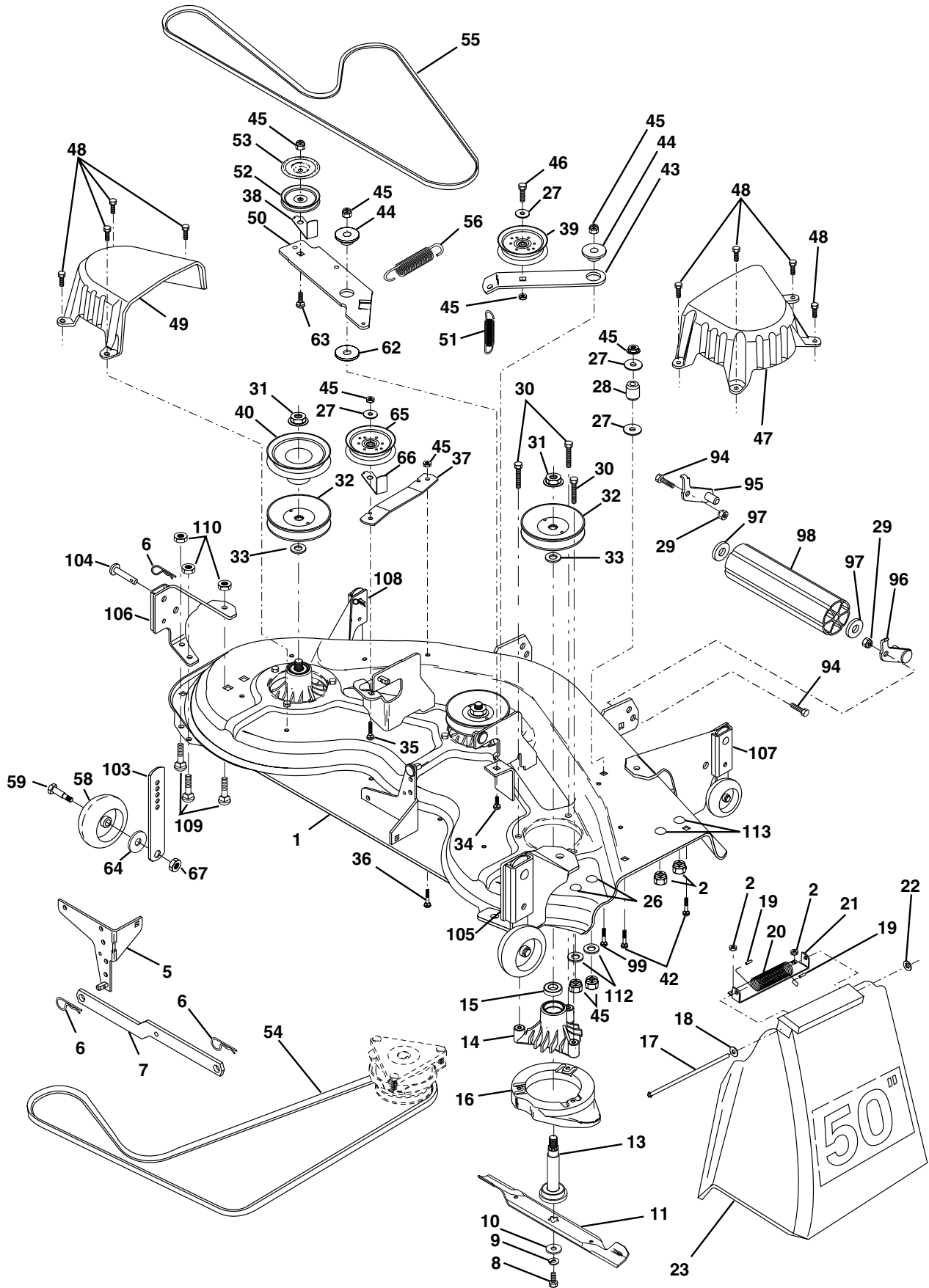

REPAIR PARTS**TRACTOR - - MODEL NUMBER PRGT22H50B****MOWER DECK**

KEY NO.	PART NO.	DESCRIPTION	KEY NO.	PART NO.	DESCRIPTION
1	156990X421	Deck Weldment 50"	47	137200	Cover, Mandrel RH
2	73680500	Nut, Crownlock 5/16-18	48	137729	Screw, Thd Roll 1/4-20 x 5/8
5	138457	Bracket Asm., Sway Bar	49	136574	Cover, Mandrel LH
6	4939M	Retainer, Spring	50	137272	Arm, Idler Primary
7	130832	Arm Suspension, Rear	51	137273	Spring, Secondary
8	850857	Bolt 3/8-24 x 1.25 Gr. 8 Patched	52	139245	Pulley, Idler V Groove
9	10030600	Washer, Lock Hvy 3/8 Unplated	53	137789	Shield, Idler
10	140296	Washer, Hard Blade Mower Vented	54	139573	V-Belt, Mower Primary
11	137380	Blade (3 Required)	55	144959	V-Belt, Mower Secondary
13	137553	Shaft Asm., W/Lower Brg	56	138687	Spring, Primary
14	137152	Housing, Mandrel 50" Vent	58	133957	Wheel, Gauge
15	110485X	Bearing, Ball Mandrel	59	137644	Bolt, Shoulder
16	174493	Stripper, Mower Vented	62	133943	Washer Hardened
17	106735X	Rod, Hinge	63	72110612	Bolt Carriage 3/8-16 x 1-1/2
18	19111016	Washer 11/32 x 5/8 x 16 Ga.	64	19121414	Washer 3/8 x 7/8 x 14 Ga.
19	105304X	Cap Sleeve	65	173981	Pulley Idler Flat Mower
20	123713X	Spring, Torison Delector	66	173979	Keeper, Belt Idler 50" Vent
21	137607	Bracket, Deflector	67	73930600	Nut, Lock 3/8-16
22	110452X	Nut, Push	94	74760516	Bolt H 5/16-18
23	110509X428	Shield, Deflector Mower	95	175746	Bracket, Asm. Noseroller LH
26	72110606	Bolt RdHd Sht Sqnk	96	175747	Bracket, Asm. Noseroller RH
27	19131316	Washer 13/32 x 13/16 x 16 Ga.	97	19171416	Washer 17/32 x 7/8 x 16 Ga.
28	132823	Spacer, Spring Stop Idler	98	132264	Roller, Nose
29	73800500	Nut, Lock Hex w/Ins. 5/16-18 Unc	99	72110614	Bolt, Carriage 3/8-16 x 1-3/4 Gr. 5
30	157722	Screw Thd Rolling Washer Head	103	155986	Bar Adj. Gauge Wh.
31	137266	Nut, Flg Top Lock Cntr 9/16	104	156941	Pin Head Rivot
32	173436	Pulley, Mandrel	105	156852	Bracket Ga Wh Asm RH 50
33	129963	Washer, Spacer Mower Vented	106	156853	Bracket Ga Wh Asm LH 50
34	72140610	Bolt, Carriage 3/8-16 x 1-1/4	107	156854	Bracket Ga Wh Assy F RH 50
35	72110616	Bolt, Carriage 3/8-16 x 2	108	156856	Bracket Ga Wh Assy F LH 50
36	72110608	Bolt, Carriage 3/8-16 x 1 Gr. 5	109	72010505	Bolt Carriage 5/16- 18 x 5/8
37	137166	Stiffener, Arm Idler	110	73980500	Nut Crownlock 5/16-18
38	173968	Keeper, Belt Idler	112	19171216	Washer 17/32 x 3/4 x 16 Ga.
39	173438	Pulley, Idler Flat	113	72110504	Bolt Carriage 5/16-Unc 1/2
40	173980	Pulley, Driven	--	143651	Mandrel Asm (Includes Key Nos. 8-10, 13-15, 31 and 33)
42	72140506	Bolt, Carriage 5/16-18 Unc x 3/4	--	173532	Replacement Mower, Complete
43	136460	Arm, Idler Secondary			
44	122052X	Spacer, Retainer			
45	73680600	Nut, Crownlock 3/8-16 Unc			
46	74760628	Bolt, Fin Hex 3/8-16 Unc x 1-3/4			

NOTE: All component dimensions given in U.S. inches
1 inch = 25.4 mm

REPAIR PARTS

TRACTOR - - MODEL NUMBER PRGT22H50B

DECALS

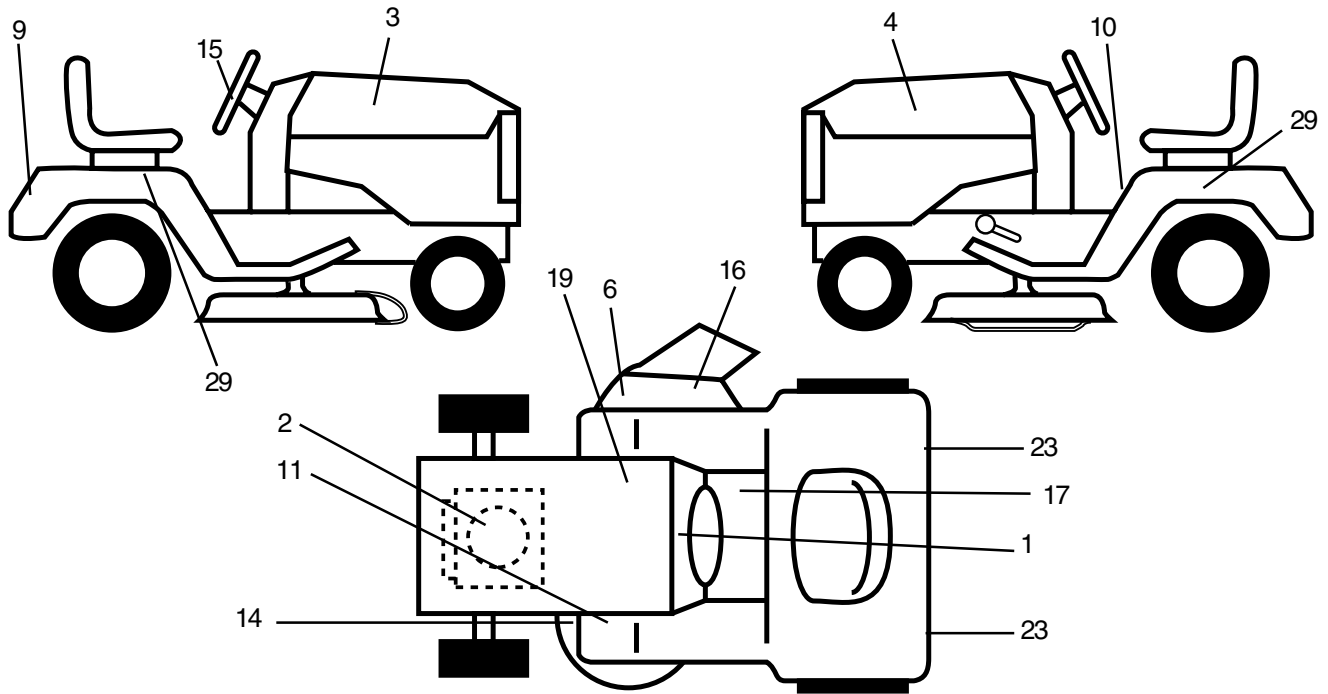

KEY NO.	PART NO.	DESCRIPTION
1	164095	Decal, Dash
2	170852	Decal, Engine
3	176272	Decal, Hood, RH
4	176273	Decal, Hood, LH
6	170563	Decal, Warning
9	172740	Decal
10	157140	Decal, Danger
11	101892X	Decal, Clutch/Brake
14	160397	Decal, V-Belt Schematic
15	172743	Decal, Ins. Whl. Strg.

KEY NO.	PART NO.	DESCRIPTION
17	140837	Decal, Saddle Brake Parking
19	145005	Decal, Battery
23	106202X	Reflector, Taillight
29	176651	Decal, Fender Auto Trans
--	138311	Decal, Handle Lift (Lift Handle)
--	133671	Pad Footrest
--	142342	Decal, Control Movement
--	177937	Manual, Owner's (English)
--	177938	Manual, Owner's (French)

WHEELS & TIRES

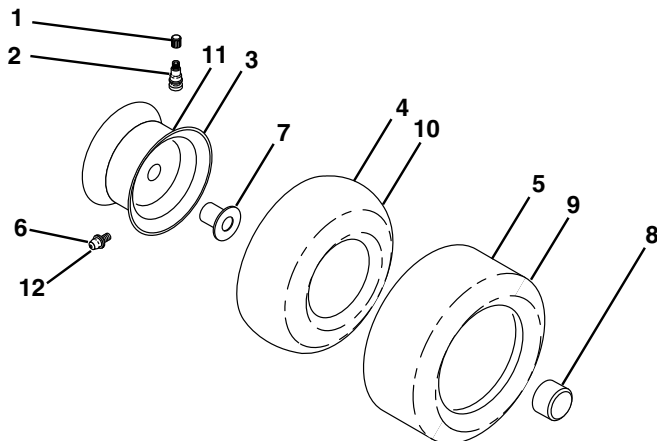

KEY NO.	PART NO.	DESCRIPTION
1	59192	Cap, Valve, Tire
2	65139	Stem, Valve
3	106228X421	Rim Assembly, Front
4	8134H	Tube, Front (Service Item Only)
5	106230X	Tire, Front
6	278H	Fitting, Grease (Front Wheel nly)
7	9040H	Bearing, Flange (Front Wheel Only)
8	104757X421	Cap, Axle (Front Wheel Only)
9	105588X	Tire, Rear
10	7154J	Tube, Rear (Service Item Only)
11	106277X421	Rim Assembly, Rear
12	6856M	Fitting, Grease
--	144334	Sealant, Tire (10 oz. Tube)

NOTE: All component dimensions given in U.S. inches
1 inch = 25.4 mm

SERVICE NOTES

SERVICE NOTES

SERVICE NOTES

LIMITED WARRANTY

The Manufacturer warrants to the original consumer purchaser that this product as manufactured is free from defects in materials and workmanship. For a period of two (2) years from date of purchase by the original consumer purchaser, we will repair or replace, at our option, without charge for parts or labor incurred in replacing parts, any part which we find to be defective due to materials or workmanship. This Warranty is subject to the following limitations and exclusions.

1. This warranty does not apply to the engine, other than EHP manufactured transaxle/transmission components, battery (except as noted below) or components parts thereof. Please refer to the applicable manufacturer's warranty on these items.
2. Transportation charges for the movement of any power equipment unit or attachment are the responsibility of the purchaser. Transportation charges for any parts submitted for replacement under this warranty must be paid by the purchaser unless such return is requested by Electrolux Home Products.
3. Battery Warranty: On products equipped with a Battery, we will replace, without charge to you, any battery which we find to be defective in manufacture, during the first ninety (90) days of ownership. After ninety (90) days, we will exchange the Battery, charging you 1/12 of the price of a new Battery for each full month from the date of the original sale. Battery must be maintained in accordance with the instructions furnished.
4. The Warranty period for any products used for rental or commercial purposes is limited to 90 days from the date of original purchase.
5. This Warranty applies only to products which have been properly assembled, adjusted, operated, and maintained in accordance with the instructions furnished. This Warranty does not apply to any product which has been subjected to alteration, misuse, abuse, improper assembly or installation, delivery damage, or to normal wear of the product.
6. Exclusions: Excluded from this Warranty are belts, blades, blade adapters, normal wear, normal adjustments, standard hardware and normal maintenance.
7. In the event you have a claim under this Warranty, you must return the product to an authorized service dealer.

Should you have any unanswered questions concerning this Warranty, please contact:

Electrolux Home Products
a division of WCI Outdoor Products, Inc.
Outdoor Products Customer Service Dept.
250 Bobby Jones Expressway
Augusta, GA 30909 USA

In Canada contact:

Electrolux Home Products
a division of WCI Outdoor Products, Inc.
7075 Ordan Drive
Mississauga, Ontario
L5T 1K6

giving the model number, serial number and date of purchase of your product and the name and address of the authorized dealer from whom it was purchased.

THIS WARRANTY DOES NOT APPLY TO INCIDENTAL OR CONSEQUENTIAL DAMAGES AND ANY IMPLIED WARRANTIES ARE LIMITED TO THE SAME TIME PERIODS STATED HEREIN FOR OUR EXPRESSED WARRANTIES. Some areas do not allow the limitation of consequential damages or limitations of how long an implied Warranty may last, so the above limitations or exclusions may not apply to you. This Warranty gives you specific legal rights, and you may have other rights which vary from locale to locale.

This is a limited Warranty within the meaning of that term as defined in the Magnuson-Moss Act of 1975.

SUGGESTED GUIDE FOR SIGHTING SLOPES FOR SAFE OPERATION

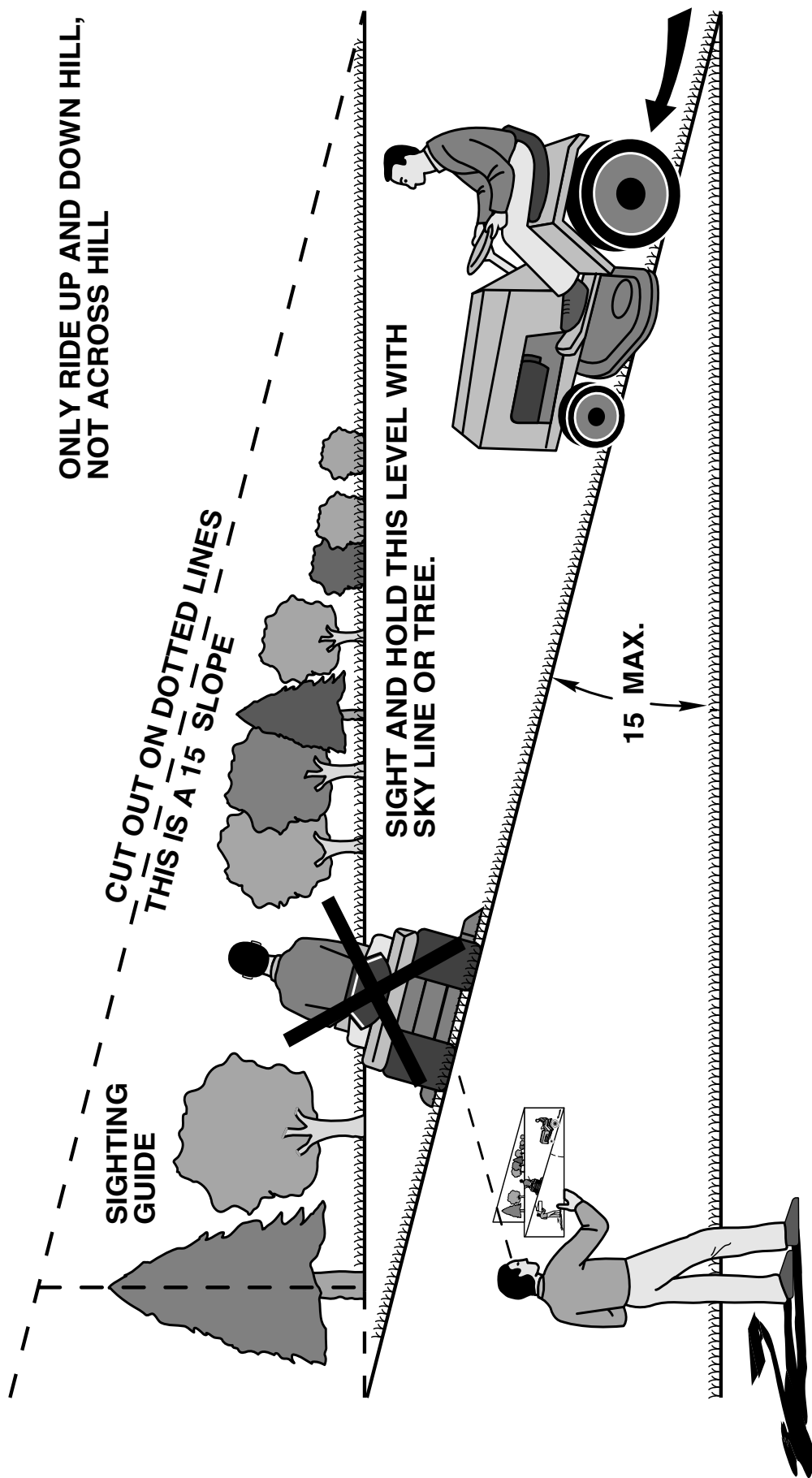

 Operate your Tractor up and down the face of slopes (not greater than 15), never across the face. Make turns gradually to prevent tipping or loss of control. Exercise extreme caution when changing direction on slopes.

PARTS AND SERVICE

Your POULAN PRO product has been expertly engineered and carefully manufactured to rigid quality standards. As with all mechanical products, some adjustments or part replacement may be necessary during the life of your unit.

FOR SERVICE OR REPLACEMENT PARTS:

1. Consult your dealer/place of purchase.
2. Consult the yellow pages of your phone directory for the name of the nearest service dealer (under “saws” for Chain Saws or under “lawn mowers” for Trimmers, Brushcutters, and Blowers).
3. For replacement parts, have available the following information:
 - a. Model Number/Manufacturer's I.D. Number
 - b. Description of part.

NOTE: Electrolux Home Products provides parts and service through its authorized distributors and dealers; therefore, all requests for parts and service should be directed to your local dealer(s). The philosophy of Electrolux Home Products is to continually improve all of its products. If the operating characteristics or the appearance of your product differs from those described in this Manual, please contact your local dealer for updated information and assistance.