

**OWNER'S MANUAL**  
**Model No. GTB48A**  
**Product No. 954 63 19-47**  
**48 Inch Mower**  
**Grass Catcher**

- **Assembly**
- **Operation**
- **Customer Responsibilities**
- **Repair Parts**



## SAFETY RULES



### Safe Operation Practices for Ride-On Mowers



**IMPORTANT:** THIS CUTTING MACHINE IS CAPABLE OF AMPUTATING HANDS AND FEET AND THROWING OBJECTS. FAILURE TO OBSERVE THE FOLLOWING SAFETY INSTRUCTIONS COULD RESULT IN SERIOUS INJURY OR DEATH.

#### I. GENERAL OPERATION

- Read, understand, and follow all instructions in the manual and on the machine before starting.
- Only allow responsible adults, who are familiar with the instructions, to operate the machine.
- Clear the area of objects such as rocks, toys, wire, etc., which could be picked up and thrown by the blade.
- Be sure the area is clear of other people before mowing. Stop machine if anyone enters the area.
- Never carry passengers.
- Do not mow in reverse unless absolutely necessary. Always look down and behind before and while backing.
- Be aware of the mower discharge direction and do not point it at anyone. Do not operate the mower without either the entire grass catcher or the guard in place.
- Slow down before turning.
- Never leave a running machine unattended. Always turn off blades, set parking brake, stop engine, and remove keys before dismounting.
- Turn off blades when not mowing.
- Stop engine before removing grass catcher or unclogging chute.
- Mow only in daylight or good artificial light.
- Do not operate the machine while under the influence of alcohol or drugs.
- Watch for traffic when operating near or crossing roadways.
- Use extra care when loading or unloading the machine into a trailer or truck.
- Data indicates that operators, age 60 years and above, are involved in a large percentage of riding mower-related injuries. These operators should evaluate their ability to operate the riding mower safely enough to protect themselves and others from serious injury.  
Keep machine free of grass, leaves or other debris build-up which can touch hot exhaust / engine parts and burn. Do not allow the mower deck to plow leaves or other debris which can cause build-up to occur. Clean any oil or fuel spillage before operating or storing the machine. Allow machine to cool before storage.

#### II. SLOPE OPERATION

Slopes are a major factor related to loss-of-control and tipover accidents, which can result in severe injury or death. All slopes require extra caution. If you cannot back up the slope or if you feel uneasy on it, do not mow it.

##### DO:

- Mow up and down slopes, not across.
- Remove obstacles such as rocks, tree limbs, etc.
- Watch for holes, ruts, or bumps. Uneven terrain could overturn the machine. *Tall grass can hide obstacles.*
- Use slow speed. Choose a low gear so that you will not have to stop or shift while on the slope.
- Follow the manufacturer's recommendations for wheel weights or counterweights to improve stability.
- Use extra care with grass catchers or other attachments. These can change the stability of the machine.
- Keep all movement on the slopes *slow* and *gradual*. Do not make sudden changes in speed or direction.
- Avoid starting or stopping on a slope. If tires lose traction, disengage the blades and proceed slowly *straight* down the slope.

##### DO NOT:

- *Do not* turn on slopes unless necessary, and then, turn slowly and gradually downhill, if possible.
- *Do not* mow near drop-offs, ditches, or embankments. The mower could suddenly turn over if a wheel is over the edge of a cliff or ditch, or if an edge caves in.
- *Do not* mow on wet grass. Reduced traction could cause sliding.
- *Do not* try to stabilize the machine by putting your foot on the ground.
- *Do not* use grass catcher on steep slopes.

#### III. CHILDREN

Tragic accidents can occur if the operator is not alert to the presence of children. Children are often attracted to the machine and the mowing activity. *Never* assume that children will remain where you last saw them.

- Keep children out of the mowing area and under the watchful care of another responsible adult.
- Be alert and turn machine off if children enter the area.
- Before and when backing, look behind and *down* for small children.
- Never carry children. They may fall off and be seriously injured or interfere with safe machine operation.
- Never allow children to operate the machine.
- Use extra care when approaching blind corners, shrubs, trees, or other objects that may obscure vision.

#### IV. SERVICE

- Use extra care in handling gasoline and other fuels. They are flammable and vapors are explosive.
  - Use only an approved container.
  - Never remove gas cap or add fuel with the engine running. Allow engine to cool before refueling. Do not smoke.
  - Never refuel the machine indoors.
  - Never store the machine or fuel container inside where there is an open flame, such as a water heater.
- Never run a machine inside a closed area.
- Keep nuts and bolts, especially blade attachment bolts, tight and keep equipment in good condition.
- Never tamper with safety devices. Check their proper operation regularly.
- Keep machine free of grass, leaves, or other debris build-up. Clean oil or fuel spillage. Allow machine to cool before storing.
- Stop and inspect the equipment if you strike an object. Repair, if necessary, before restarting.
- Never make adjustments or repairs with the engine running.
- Grass catcher components are subject to wear, damage, and deterioration, which could expose moving parts or allow objects to be thrown. Frequently check components and replace with manufacturer's recommended parts, when necessary.
- Mower blades are sharp and can cut. Wrap the blade(s) or wear gloves, and use extra caution when servicing them.
- Check brake operation frequently. Adjust and service as required.

## SAFETY RULES

### Safe Operation Practices for Ride-On Mowers



- Be sure the area is clear of other people before mowing. Stop machine if anyone enters the area.
- Never carry passengers or children even with the blades off.
- Do not mow in reverse unless absolutely necessary. Always look down and behind before and while backing.
- Never carry children. They may fall off and be seriously injured or interfere with safe machine operation.
- Keep children out of the mowing area and under the watchful care of another responsible adult.
- Be alert and turn machine off if children enter the area.
- Before and when backing, look behind and down for small children.
- Mow up and down slopes (15° Max), not across.
- Remove obstacles such as rocks, tree limbs, etc.
- Watch for holes, ruts, or bumps. Uneven terrain could overturn the machine. Tall grass can hide obstacles.
- Use slow speed. Choose a low gear so that you will not have to stop or shift while on the slope.
- Avoid starting or stopping on a slope. If tires lose traction, disengage the blades and proceed slowly straight down the slope.
- If machine stops while going uphill, disengage blades, shift into reverse and back down slowly.
- Do not turn on slopes unless necessary, and then, turn slowly and gradually downhill, if possible.



Look for this symbol to point out important safety precautions. It means **CAUTION!!! BECOME ALERT!!! YOUR SAFETY IS INVOLVED.**



**CAUTION:** Do not coast down a hill in neutral, you may lose control of the tractor.



**CAUTION:** Tow only the attachments that are recommended by and comply with specifications of the manufacturer of your tractor. Use common sense when towing. Operate only at the lowest possible speed when on a slope. Too heavy of a load, while on a slope, is dangerous. Tires can lose traction with the ground and cause you to lose control of your tractor.



**CAUTION:** In order to prevent accidental starting when setting up, transporting, adjusting or making repairs, always disconnect spark plug wire and place where it cannot contact spark plug.

**CONGRATULATIONS** on your purchase of a new Grass Catcher. It has been designed, engineered and manufactured to give you the best possible dependability and performance.

Should you experience any problems you cannot easily remedy, please contact your nearest authorized service center/ department. They have competent, well trained technicians and the proper tools to service or repair this unit.

Please read and retain this manual. The instructions will enable you to assemble and maintain your Grass Catcher properly. Always observe the "SAFETY RULES".

## TABLE OF CONTENTS

SAFETY RULES .....	2-3
CARTON CONTENTS.....	4
ASSEMBLY .....	5-7
OPERATION .....	8

CUSTOMER RESPONSIBILITIES.....	9
STORAGE .....	9
REPAIR PARTS.....	10-11

## KNOW YOUR GRASS CATCHER

READ THIS OWNER'S MANUAL AND SAFETY RULES BEFORE ASSEMBLING OR OPERATING YOUR GRASS CATCHER. Compare the illustrations with the carton contents to familiarize yourself with the parts before starting the assembly. Study the operating instructions and safety precautions thoroughly to insure proper functioning of your Grass Catcher and to prevent injury to yourself and others. Save this manual for future reference.



The operation of any tractor can result in foreign objects thrown into the eyes, which can result in severe eye damage. Always wear safety glasses or eye shields before starting your tractor and while mowing. We recommend a wide vision safety mask for over the spectacles or standard safety glasses.

## UNPACKING INSTRUCTIONS

- Remove all parts and packing materials from carton.
- Check carton contents against list. Be sure all parts are there.

## CARTON CONTENTS:

- |                       |                      |
|-----------------------|----------------------|
| (3) Container Tops    | (1) Lower Chute      |
| (3) Container Bottoms | (1) Support Assembly |
| (1) Upper Chute       | (1) Cover Assembly   |

## PARTS IDENTIFICATION

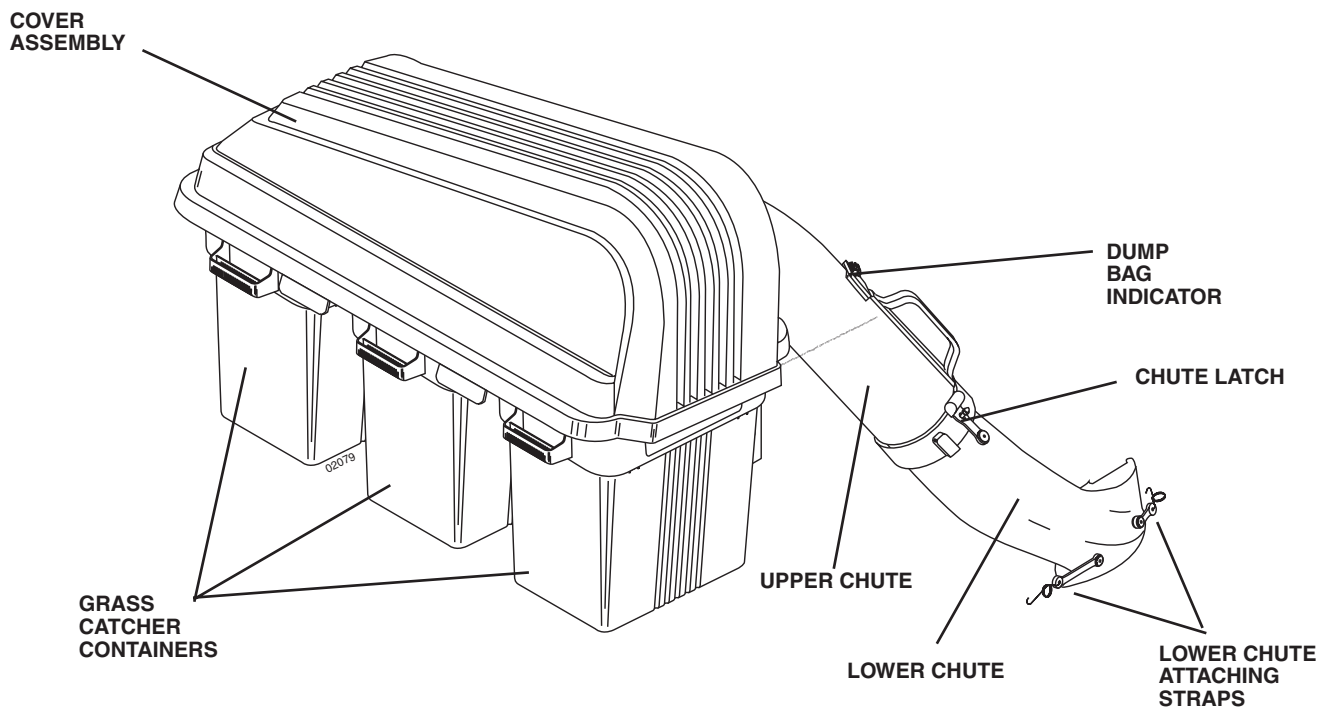

**NOTE:** When right hand (R.H.) and left hand (L.H.) are mentioned in this manual, it means when you are seated on the tractor, in the operator's position.

### CAUTION: BEFORE ASSEMBLING GRASS CATCHER TO TRACTOR:

- Depress clutch/brake pedal fully and set parking brake.
- Place gearshift/motion control lever in "NEUTRAL" position.
- Place attachment clutch in "DISENGAGED" position.
- Turn ignition key "OFF" and remove key.
- Make sure the blade and all moving parts have completely stopped.
- Disconnect spark plug wire from spark plug and place wire where it cannot come in contact with plug.



# ASSEMBLY

## 1 BAGGER SUPPORT ASSEMBLY (See Fig. 1)

1. Remove retainer spring from lower pin on support assembly.
2. Insert support assembly mounting flanges into slots of rear drawbar. Rotate in and down to insert support assembly pin into hole in drawbar.
3. Be sure support assembly is seated properly and secure with retainer spring.

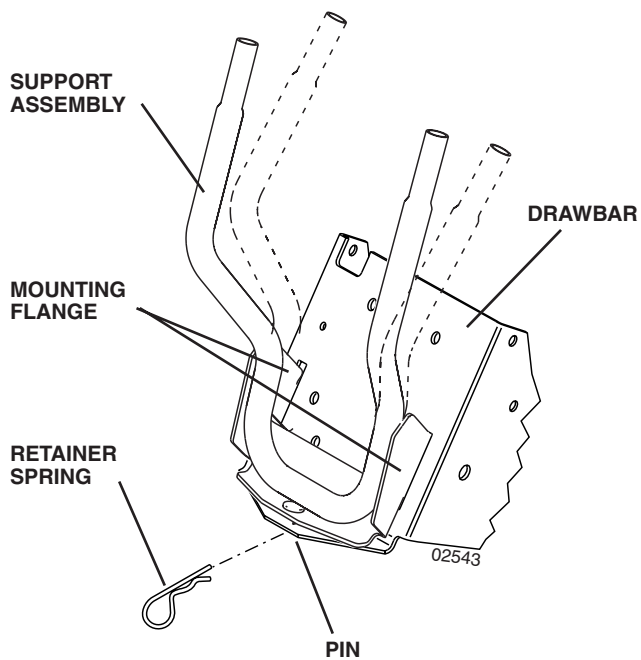

FIG. 1

## 2 MOUNTING COVER ASSEMBLY TO SUPPORT ASSEMBLY (See Fig. 2)

**NOTE:** For ease of assembly, you may wish to obtain the assistance of another person for mounting cover assembly to tractor.

1. Position cover assembly on ground behind tractor as shown.
2. Lift and rotate cover to align cover brackets with support assembly tubes.
3. Slide cover assembly down onto the support tubes.

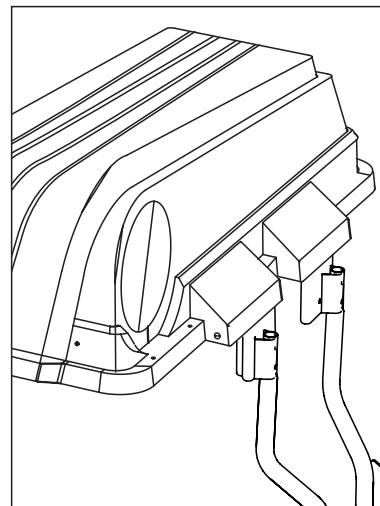
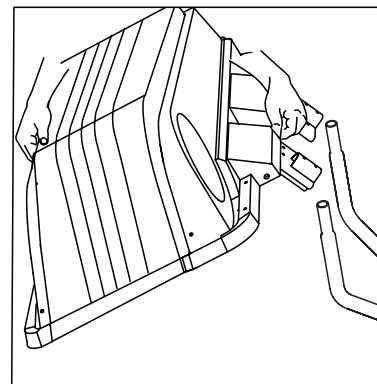
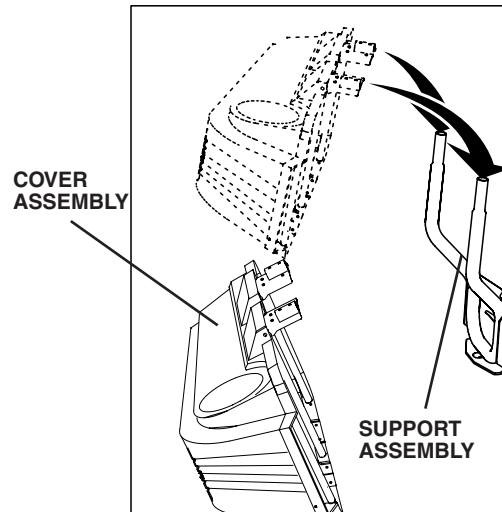

FIG. 2

### 3 CONTAINER ASSEMBLY (See Fig. 3)

1. Place bottom half inside of top half, as shown.
2. Place one foot inside bottom half and lift top half to meet bottom half.
3. Press halves tightly together while lifting top to lock into place as shown.

**IMPORTANT:** BEFORE LOCKING THE TABS, HOOKED EDGES ON BOTH HALVES MUST OVERLAP TO FORM SEAL AS SHOWN IN INSET.

4. Repeat for other containers.

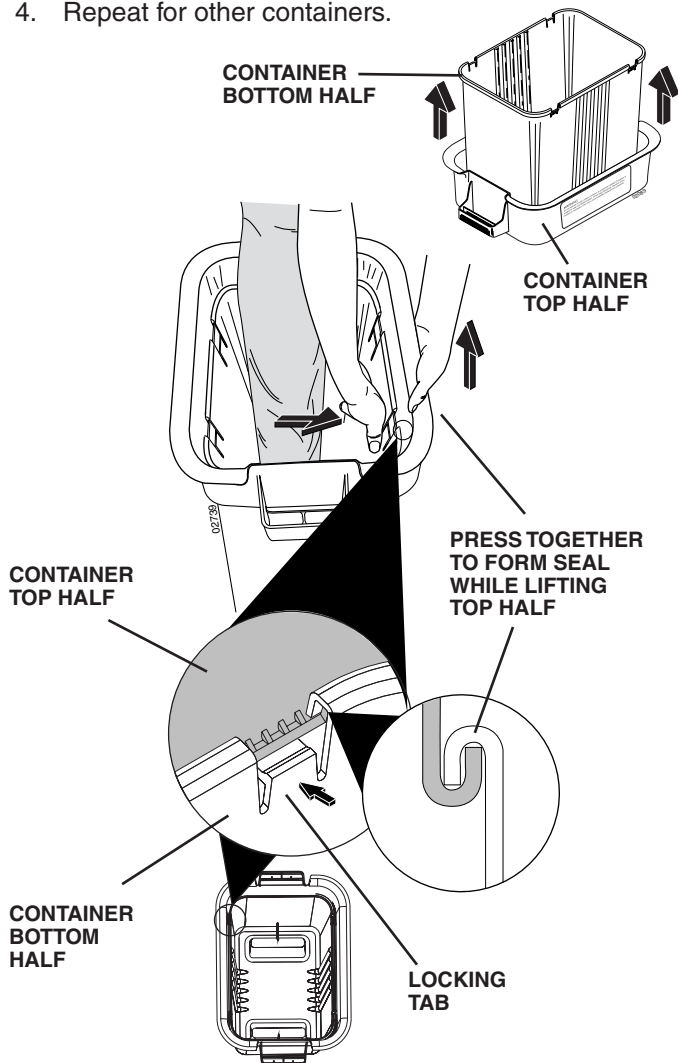
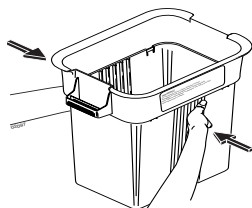

FIG. 3

**ASSEMBLY CHECK:** Squeeze sides of lower half of container and check that there is no gap between upper and lower halves. If a gap appears, unlock tabs to separate container halves and repeat instructions above.



### 4 CONTAINER MOUNTING (See Fig. 4)

1. Install one container to left side first with warning to outside of unit. Install another container to center position and one in right position.

**NOTE:** Right container should always overlap left container at center supports.

2. Close cover and lock latch handles over center support tubes.

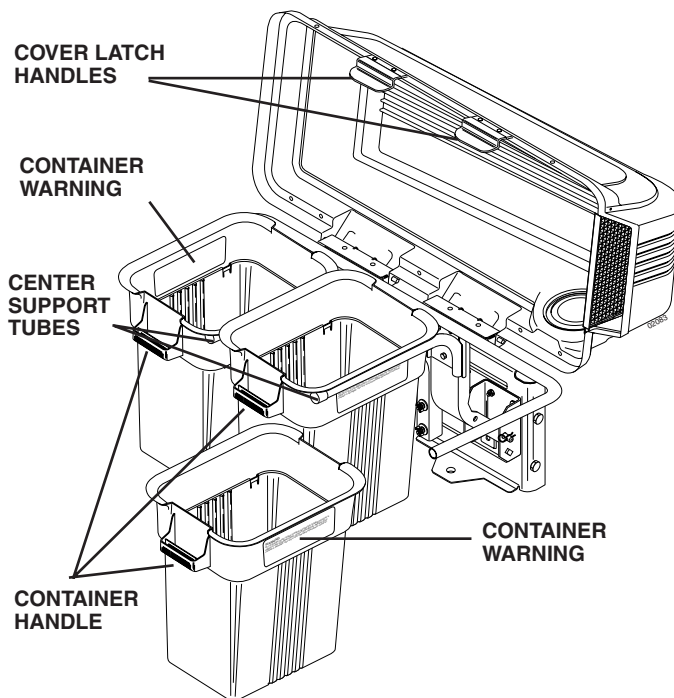

FIG. 4

## 5 LOWER CHUTE (See Fig. 5)

1. Raise and hold deflector shield in upright position.
2. Place slot in lower chute over tab on mower deck and position lower chute over deck opening as shown.
3. Hook rear latch into flange hole on back of mower deck.
4. Hook front latch into tab hole on front of mower deck.



**CAUTION:** Do not remove deflector shield from mower. Raise and hold shield when attaching lower chute and allow it to rest on chute while in operation.

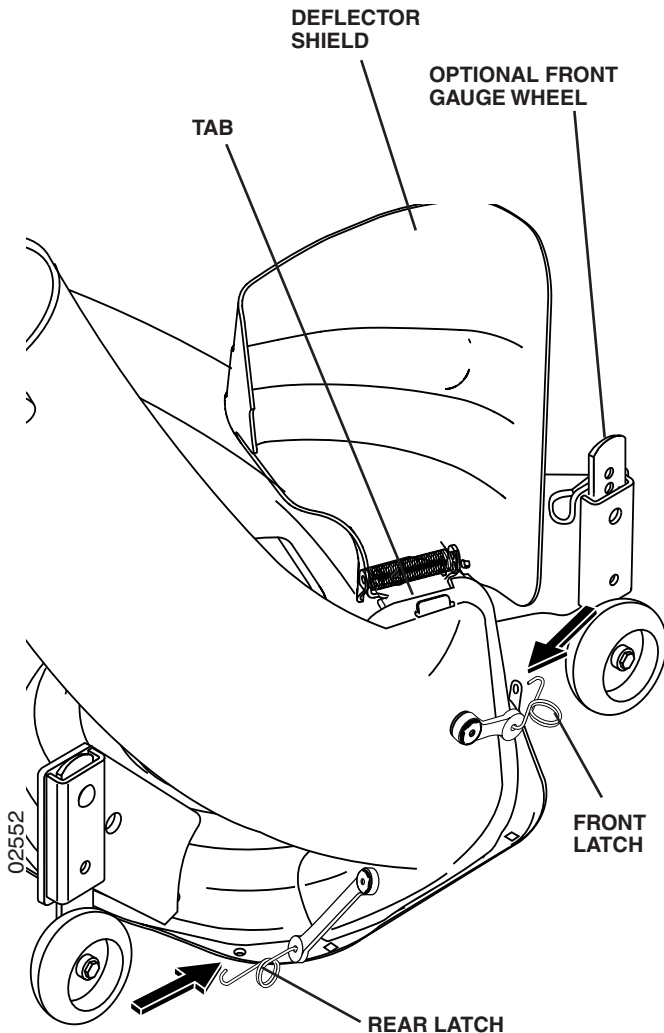

FIG. 5

## 6 UPPER CHUTE (See Figs. 6A & 6B)

1. Lower mower deck to its lowest cutting position.
  2. Assemble upper chute by inserting curved end into hole in back of cover.
- NOTE:** Handle carefully so as not to damage dump bagger indicator.
3. Push in and turn upper chute until it is in line with lower chute.
  4. Align the bosses on lower chute with alignment slots on upper chute and slide together.
  5. Secure with rubber latch by hooking hole in latch over latch pin.

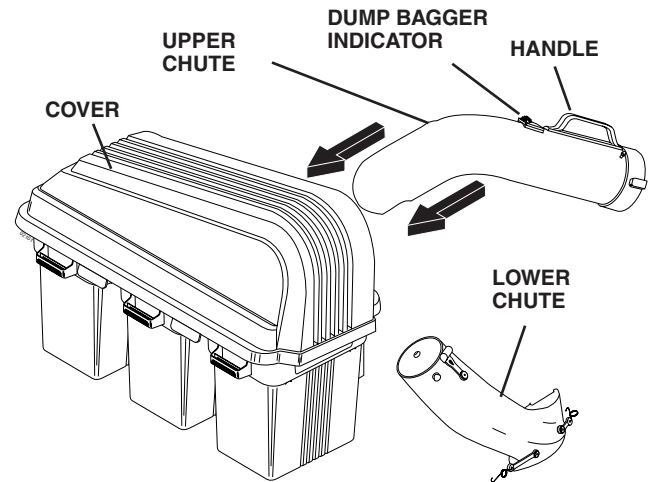

FIG. 6A

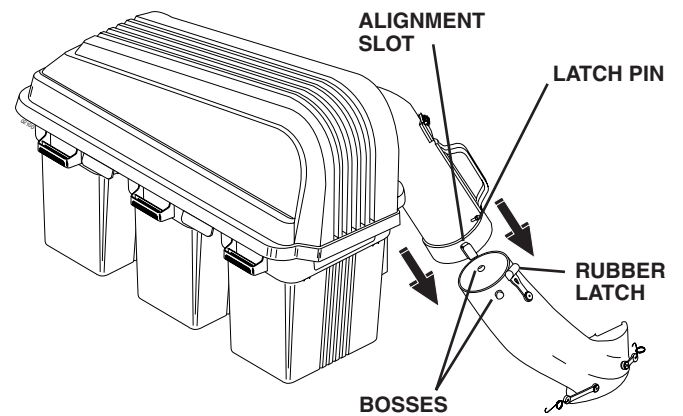

FIG. 6B

## 7 LEVEL MOWER DECK

- Be sure deck is properly leveled for best mower performance. See your tractor's owner's manual for instructions

# OPERATION

## TIPS FOR IMPROVED BAGGING OPERATION:

Follow the mower operation instructions in your tractor owner's manual.

When operating your grass catcher on a lawn where grass and leaf bagging equipment has not been used, you are picking up thatch and debris that has accumulated for long periods of time. The amount collected and the total time of operation may be greater than you will experience with regular use of your grass catcher.

- Always run throttle at full speed when bagging.
- Select a gear low enough to give good mower cutting performance, good quality cut and good bagging performance.

**NOTE:** It may be necessary to overlap width of cut to suit your conditions.

- If grass is extremely tall, it should be mowed twice. The first time relatively high, the second time to desired height.
- Use left hand side of mower for trimming.
- Plastic trash bags can be inserted inside grass catcher containers for ease of debris disposal. To remove the plastic trash bags when full:
  - a. Disengage blades, shift into neutral, engage the parking brake and stop the engine.
  - b. Raise seat. Unlatch and raise cover.
  - c. Remove one container at a time by grasping container handles and pulling toward the rear, off of the tube rails.
  - d. With the container resting on the ground, close and secure the top of the plastic lawn bag.
  - e. Tip the container on its side and slide the filled bag from the container.
  - f. Install a new plastic lawn bag with the edges of the bag draped over upper lip of the container.
  - g. Repeat for other containers.
  - h. Reinstall containers making sure right container overlaps left container at center supports.
  - j. Close cover and secure latches over center support tubes.

- Avoid cutting wet grass or in the morning while the dew is still heavy. Grass clippings collected under these conditions tend to be sticky and adhere to the walls of the flow path causing clogging.
- Your bagger is equipped with a dump bag indicator. As the bags become full, the flow indicating ball will drop down in its slot, indicating that the bags are full or the chutes have become clogged. Care should be taken not to damage the parts and that the ball moves freely at the beginning of each use.

**NOTE:** To help prevent clogging of chutes, check/empty bags when ball begins to drop down in the slot. Experience will teach you the best time to empty the bags.

- If the grass catcher fails to pick up cut grass or leaves, it is an indication that clogging has occurred in the system or that the grass catcher containers are full.
  - a. Disengage blades, shift into neutral, engage the parking brake and stop the engine.
    - Raise seat. Unlatch and raise cover.
    - Slide out containers and dispose of clippings .
    - Replace containers, close cover, and latch.
  - b. Unlatch chutes and check for clogging
    - Remove all debris in chutes.
    - Reassemble and latch chutes
  - c. Check to insure dump bag indicator has not become clogged.
    - The air passage hole must be clear of debris. Gently insert a small twig or wire into passageway to clear.



### CAUTION

- Do not operate mower with grass catcher partially installed.
- Disengage blades and stop engine before leaving tractor seat to empty containers, unclogging chutes, etc.
- Close cover before starting.
- Disengage mower when crossing driveways or gravel surfaces and other areas where thrown objects could be a hazard.
- Do not attempt to vacuum up cans or other potentially hazardous projectiles.



# CUSTOMER RESPONSIBILITIES

## GENERAL RECOMMENDATIONS

Always observe safety rules when performing any maintenance.

- Before each use check for loose fasteners.
- Clean unit thoroughly after each use.

## BLADE CARE

For best results mower blades must be kept sharp. Replace bent or damaged blades.

- See BLADE CARE instructions in your tractor owner's manual.

## STORAGE

When grass catcher is to be stored for a period of time, clean it thoroughly, remove all dirt, grass, leaves, etc. Store in a clean, dry place.



**CAUTION: Do not leave grass in bagger containers. Empty containers after each use and before storing. Failure to do so may result in spontaneous combustion which could develop into a fire.**



**CAUTION: BEFORE PERFORMING ANY MAINTENANCE, SERVICE OR ADJUSTMENTS:**

- Depress clutch brake pedal fully and set parking brake.
- Place gearshift/motion control lever in "NEUTRAL" position.
- Place clutch control in "DISENGAGED" position.
- Turn ignition key to "OFF" position.
- Make sure blades and all moving parts have completely stopped.
- Disconnect spark plug wire(s) from spark plug(s) and place wire where it cannot come in contact with plug.



**CAUTION: Grass catcher components are subject to wear, damage and deterioration, which could expose moving parts or allow objects to be thrown. Frequently check components and replace with manufacturer's recommended parts, when necessary.**

# REPAIR PARTS/PIÈCES DE RECHANGE

GRASS CATCHER - - MODEL NUMBER GTB48A / RAMASSE-HERBE - - NUMÉRO DE MODÈLE GTB48A  
PRODUCT NUMBER 954 63 19-47 / NUMÉRO DE PRODUIT 954 63 19-47

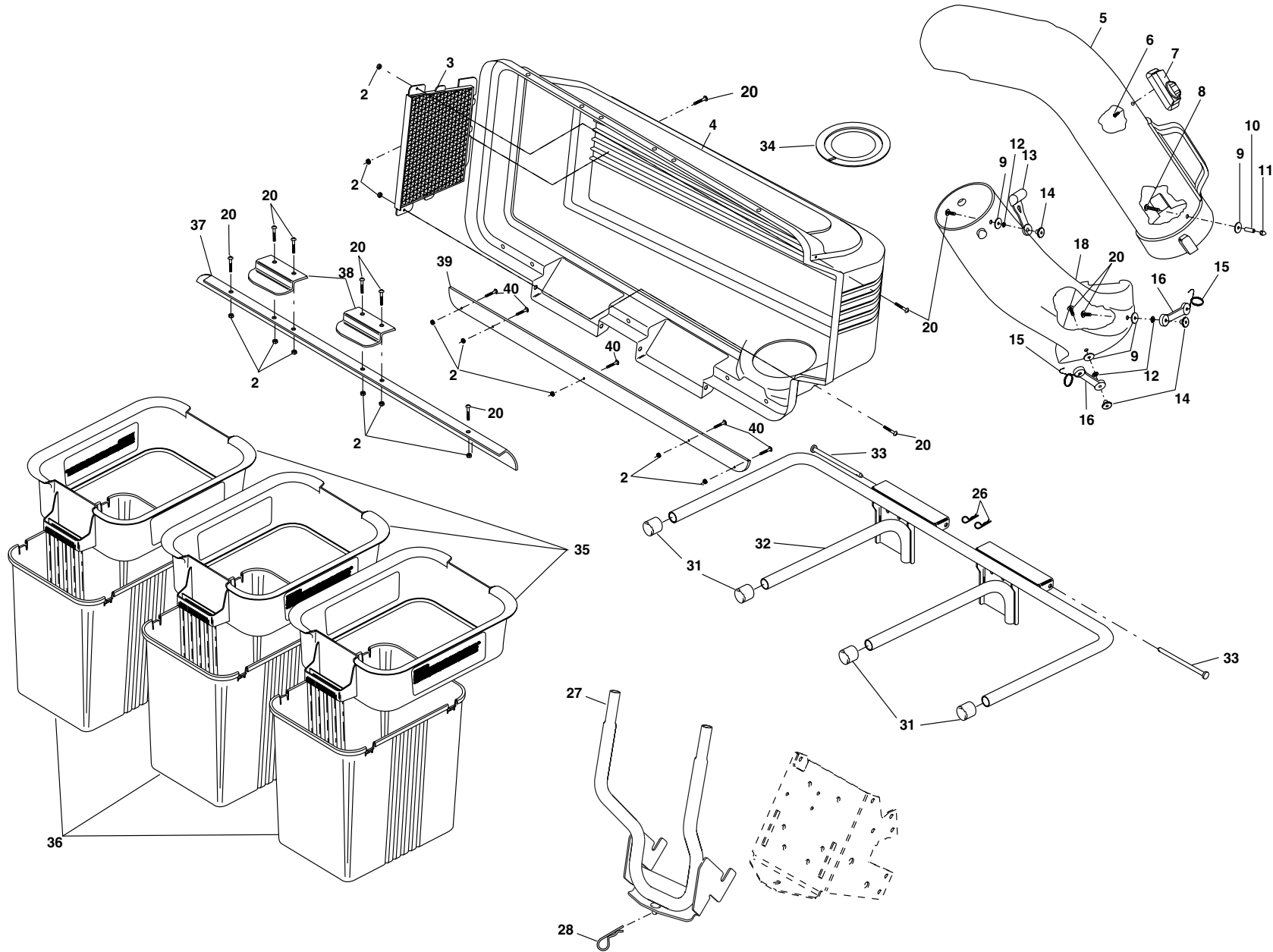

# REPAIR PARTS/PIÈCES DE RECHANGE

GRASS CATCHER - - MODEL NUMBER GTB48A / RAMASSE-HERBE - - NUMÉRO DE MODÈLE GTB48A  
 PRODUCT NUMBER 954 63 19-47 / NUMÉRO DE PRODUIT 954 63 19-47

KEY NO.	PART NO.	DESCRIPTION	KEY NO.	PART NO.	DESCRIPTION
2	532069180	Nut, Crownlock #10-24	18	532174345	Chute, Lower
3	532127533	Screen, Cover	20	871161010	Screw #10-24 x 5/8
4	532139850	Cover Assembly (Includes 3, 37, 38, 39)	26	532124670	Spring, Retainer
5	532176741	Chute, Upper	27	532176987	Support Assembly
6	818021008	Screw, Special #10-14x1/2	28	532165898	Spring, Retainer
7	532140572	Dump bag Indicator	31	532174083	Plug, Tubing End
8	532087175	Screw, #10-24 x 1-1/8	32	532176990	Bagger, Frame
9	819061216	Washer 3/16x3/4x16 Ga.	33	532128600	Pin, Hinge
10	532007206	Spacer, Split	34	532127534	Gasket, Cover
11	532060867	Nut, Acorn #10-24	35	532183286	Container, Top
12	810071000	Washer, lock	36	532129586	Container, Bottom
13	532109808	Latch, Chute	37	532134637	Seal, Cover
14	532125004	Nut, Weld	38	532130895	Latch Handle, Cover
15	532130760	Latch, Hook	39	532186601	Strip, Reinforcement
16	532130759	Rubber, Latch	40	871141008	Screw #10-24 x 1/2
			—	532178403	Owner's Manual



For Parts Call K&T 606-678-9623 or 606-561-4983

www.mymowerparts.com