

For Husqvarna Parts Call 606-678-9623 or 606-561-4983

 **Husqvarna**

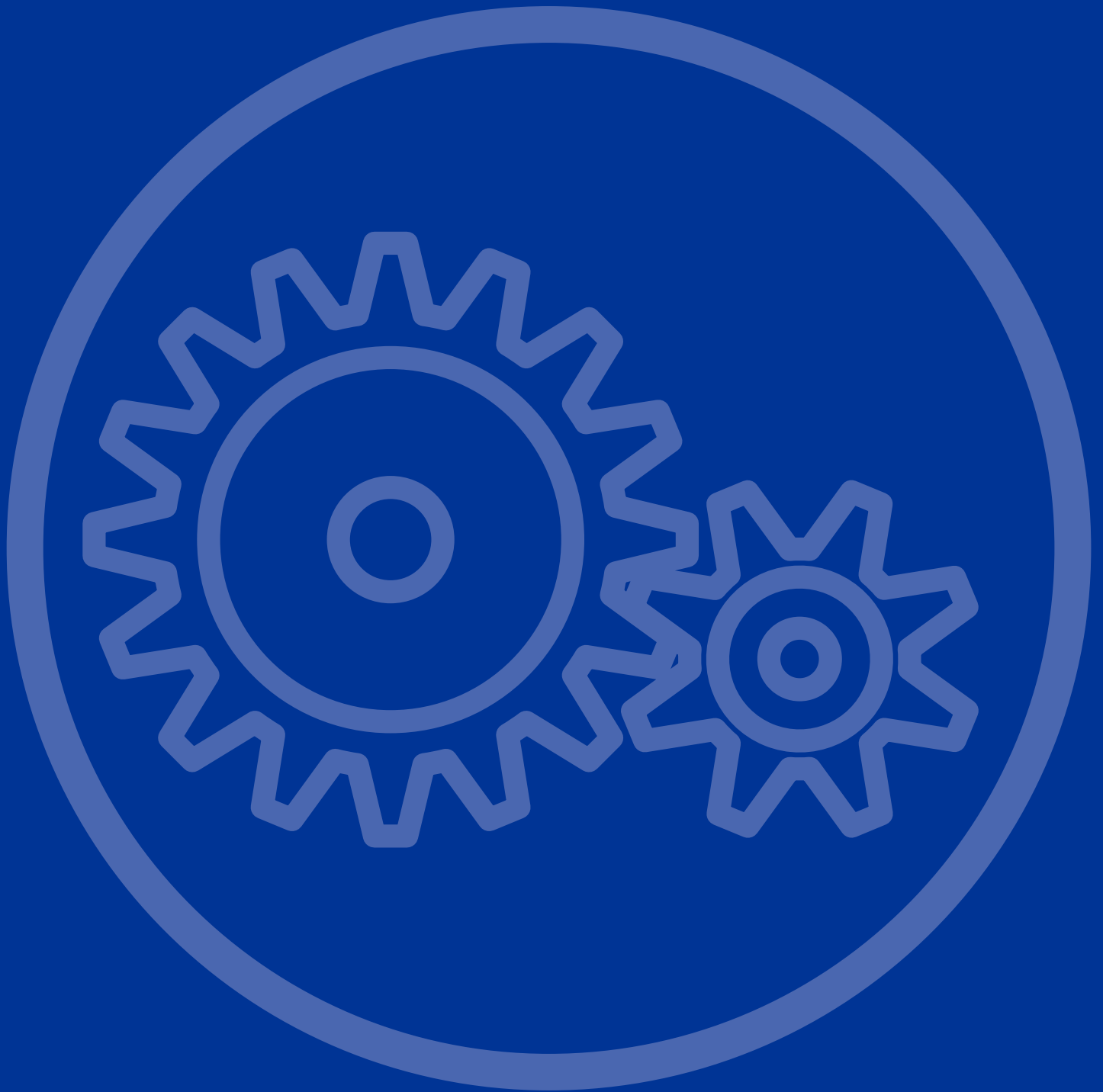

Workshop manual
343R 345RX
343F 345FX 345FXT

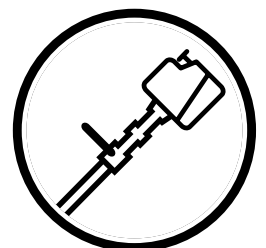

English

www.mymowerparts.com

For Husqvarna Parts Call 606-678-9623 or 606-561-4983

Workshop Manual Brushcutter, Trimmer

Model 343R, 345RX, 343F, 345FX, 345FXT

Contents

General recommendations _____	2
1. Starter _____	3
2. Electrical system _____	7
3. Fuel system _____	15
4. Centrifugal clutch _____	31
5. Angle gear _____	37
6. Cylinder and piston _____	41
7. Crankshaft and crankcase _____	51
8. Tools _____	59



© Copyright Husqvarna AB, Sweden 2003

General recommendations

Remember:

- ⚠ Never start the engine without the clutch and clutch drum mounted.
 - ⚠ Do not grasp hot elements such as the muffler or the clutch before they have cooled sufficiently to avoid burn injuries.
 - ⚠ Avoid getting petrol on you skin or in your mouth. Use protective cream on your hands. This lowers the risk of infection and makes dirt easier to wash off. Long-term contact with engine oil can be damaging to your health.
 - ⚠ Never run the engine indoors. The engine exhaust is poisonous!
 - ⚠ Wipe up any spilled oil from the floor immediately in order to avoid injuries from slipping.
 - ⚠ Do not use tools that are worn or fit poorly on nuts and bolts and so on.
- + Always work on a clean work surface.
 - + Always work in a logical manner in order to be sure that all components are correctly attached and that nuts and bolts are tightened.
 - + Use special tools where recommended in order to work correctly.

Fire risk

- Handle petrol with respect, since it is highly flammable.
- Do not smoke and ensure that there are no open flames or sparks in the vicinity.
- Make sure that there is a functioning fire extinguisher in the vicinity.
- Do not try to extinguish a petrol fire with water.

Poisonous fumes

- When using cleaning fluids, read the instructions carefully.
- Make sure that ventilation is good when handling petrol, trichloroethylene and other highly volatile liquids.
- The engine exhaust is poisonous. Test run the engine only if ventilation is good. Preferably outside.

Special tools

Certain tasks in this handbook require the use of special tools. In sections where this is applicable, an image of the tool with an ordering number is provided.

We recommend using special tools in order to avoid personal injury and to eliminate expensive damage to the components in question.

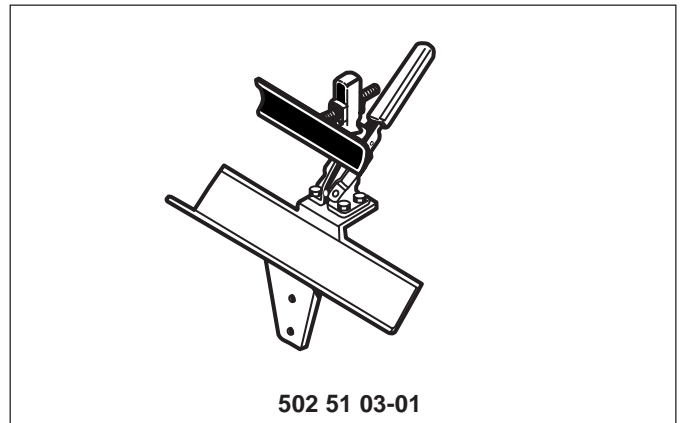

Sealing faces and gaskets

Make sure that all sealing faces are clean and free from old gasket remnants. Use a tool that will not damage the sealing face when it is cleaned. Any scratches and irregularities should be removed with a fine, float-cut file.

Sealing rings

Always change a sealing ring once it has been dismantled. The sensitive sealing lips can be easily damaged with poor sealing ability as a result. The surfaces that the seal is to tighten against must also be completely free from damage. Lubricate the sealing lip with grease before it is attached and make sure that it is not damaged by such things as the collars and splines on an axle. Use tape or a conical bushing as protection. It is important that the sealing ring is turned correctly in order for it to function as intended.



WARNING!

Risk of personal injury if the instructions are not followed.

NOTE!

Material damage may occur if the instructions are not followed.

Starter

1.

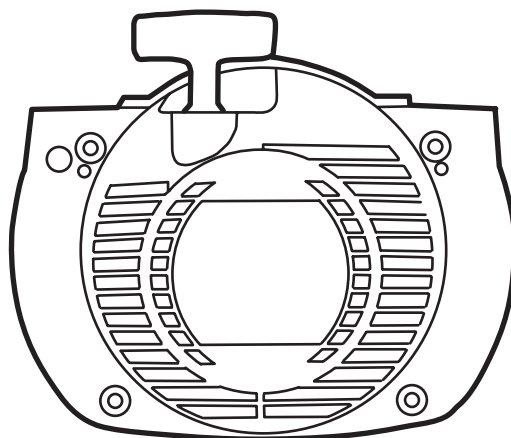

Contents

Dismantling _____	4
Assembly _____	5
Replacing the drive dogs _____	6



WARNING!

Protective glasses should be worn when working on the starter to avoid injury to the eyes if, for some reason, the return spring should fly out.

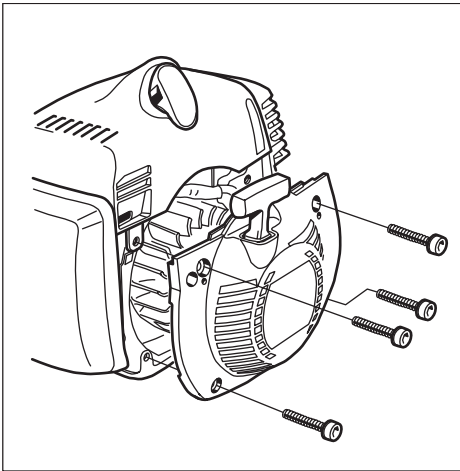

Dismantling

Remove the starter from the engine.

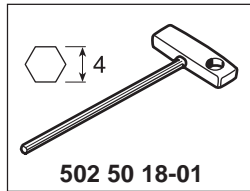

Loosen the spring tension.

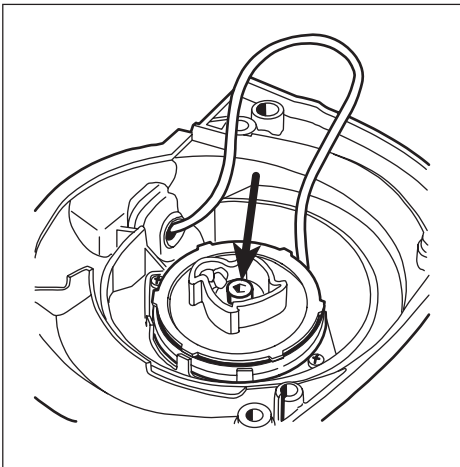
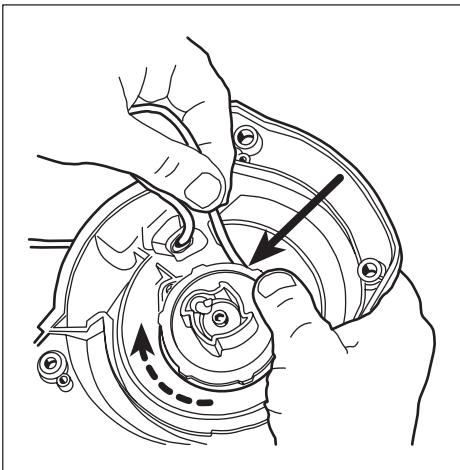

Remove the bolt in the centre of the starter pulley and remove the starter pulley.

Dismantling

Remove the 4 bolts and lift off the starter.

The cylinder cover does not need to be loosened or detached.

Loosen the spring tension.

Pull out the starter cord about 30 cm. Brake the starter pulley with your thumb and lift the cord as illustrated.

Let the starter pulley rotate backwards slowly.

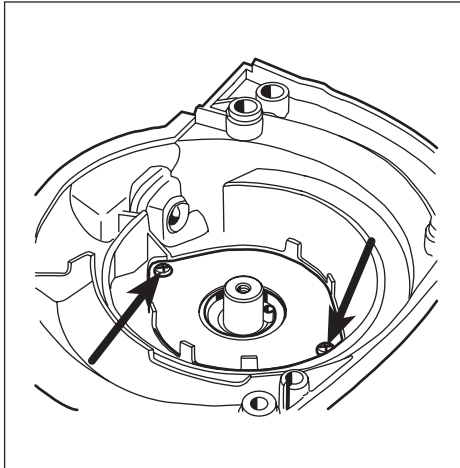

Remove the bolt in the centre of the starter pulley. Lift the starter pulley carefully from the starter cover.

Starter



Remove the spring cassette.

Remove the two bolts holding the spring cassette and remove the cassette for replacement if necessary.

  **WARNING!**
Wear protective glasses. The return spring can fly out and cause personal injury if improperly handled.

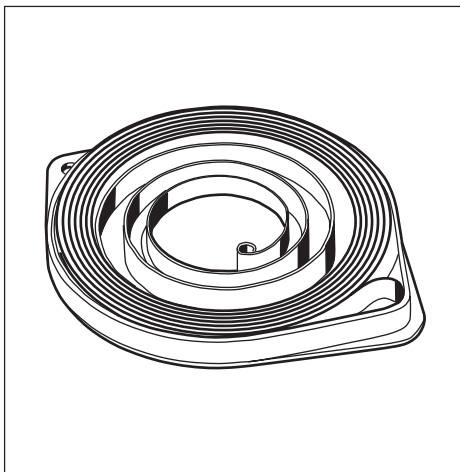

Assembly

Clean requisite parts and assemble in the reverse order as set out for dismantling.

Assembly

Clean all components before assembly:
Change return springs, starter pulley and starter cord as needed.

NOTE!
Be careful when opening the packaging with the return spring so that the spring does not fly out.

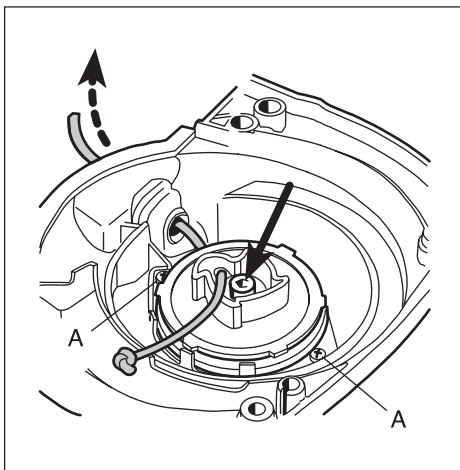

Attach the spring cassette.
Attach the starter pulley.
Attach the new starter cord.

Attach the spring cassette and tighten the two bolts (A).
Lubricate the bearing journal with a little grease and attach the starter pulley.
Place the washer in place and tighten the bolt.
Attach the new starter cord. Push it in to the starter pulley's track as illustrated and then out through the cord guide in the starter cover. Make sure that the knot at the end of the cord is as small as possible!

NOTE!
New starter cords can be attached without dismantling the starter!

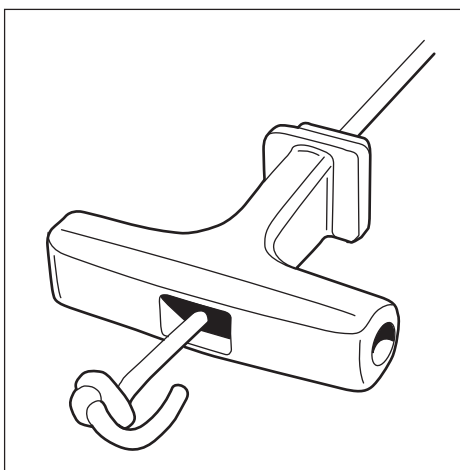

Anchor the cord in the starter handle.

Thread the cord through the starter handle and anchor it with a knot.
Fold down the free end and pull the knot well into the handle.

Starter

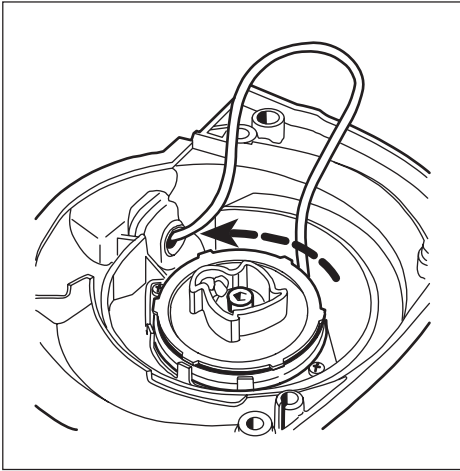

Tighten the return spring.
Check the spring tension.

Tighten the return spring.
Lift up the starter cord when the return spring is completely loose and the cord pulled out completely.
Then turn the starter pulley *anti-clockwise* 7 revolutions.
Check the spring tension. With the cord completely pulled out the cord pulley should be able to be turned at *least another half revolution*.

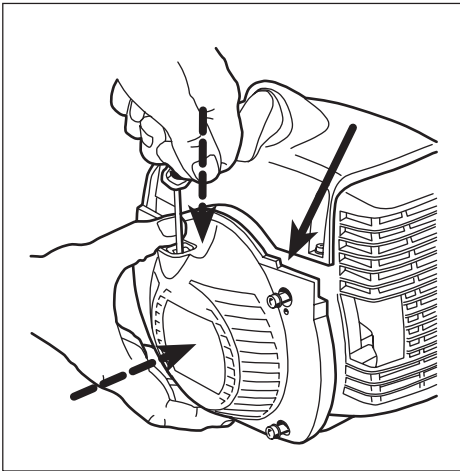

Mount the starter onto the engine.

Mount the starter onto the engine.
Pull out the starter cord a little.
Place the starter in position and release the starter cord at the same time.
Check that the ignition cable is not trapped (see arrow).
Check that the drive dogs grip the starter pulley in the correct way.
Tighten the bolts.

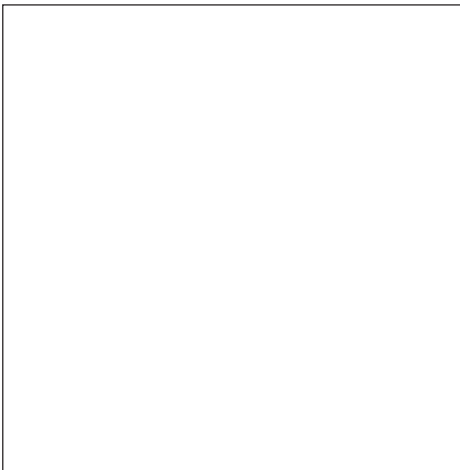

Replacing the drive dogs
See chapter 2 Ignition system.

Replacing the drive dogs
See chapter 2 Ignition system.

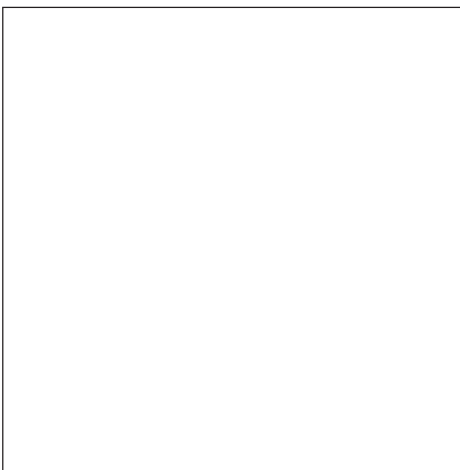

Electrical system

2.

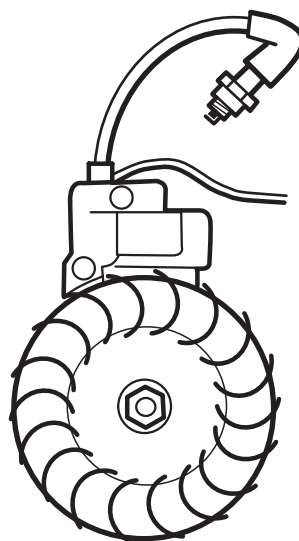

Contents

Checking the ignition spark _____	8
Replacing the spark plug cover _____	10
Dismantling _____	11
Drive dogs _____	12
Assembly _____	12
Heated handles _____	12

2 Electrical system

The engine is equipped with an electronic ignition system completely without moving parts. Consequently, a faulty component cannot be repaired, but must be replaced by a new component.

The spark in an electronic ignition system has a very short burn time and can therefore be interpreted as weak and can be difficult to see while troubleshooting.

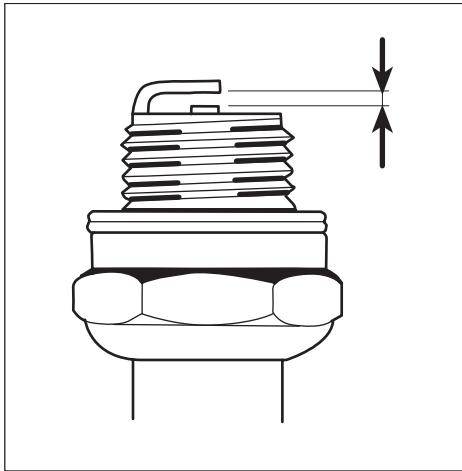

Checking the ignition spark

Clean the electrodes and check the electrode gap.

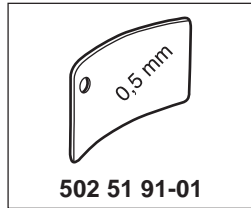

502 51 91-01

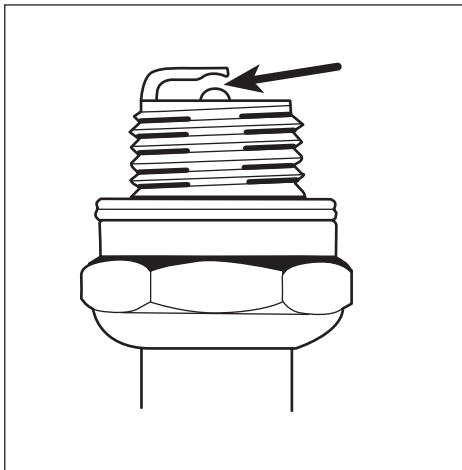

If the electrodes are worn more than 50% the spark plug should be changed.

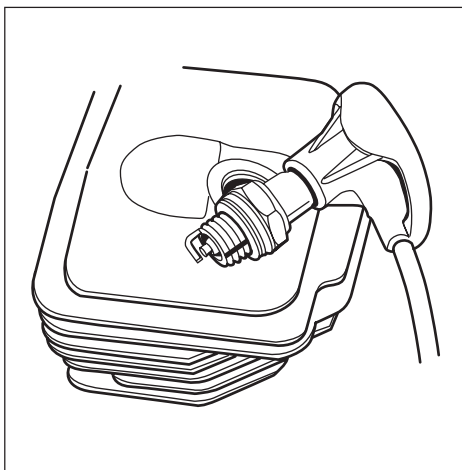

Check if a spark occurs when attempting to start.

Test with test spark plug no. 502 71 13-01 if no spark is seen.

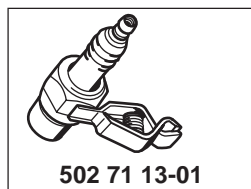

502 71 13-01

Checking the ignition spark

Remove the spark plug and clean it from soot deposits with the help of a steel brush.

Check the electrode gap. It should be 0.5 mm.

Adjust the gap as needed to the correct value with the side electrode.

If the electrodes are worn more than 50% the spark plug should be changed.

Too large a spark gap entails a great deal of stress on the ignition module and risk for short-circuiting.

Also check that the stop switch is in the start position.

Earth the spark plug on the cylinder and pull sharply on the start handle.

A spark should be seen between the electrodes.

If no spark is seen test with test spark plug no. 502 71 13-01.

If a spark then occurs, the spark plug is faulty.

Try a new spark plug.

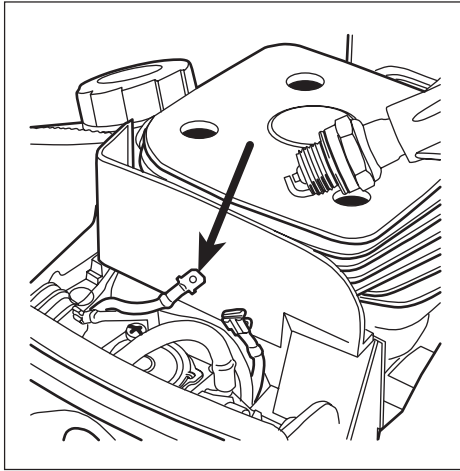

If no spark occurs, disconnect the stop switch.
Replace the switch if necessary

If no spark occurs even now, remove the short-circuit cable from the connection point in the carburettor compartment.

If the plug now sparks, the fault is either in the stop switch or the short-circuit cable.

Change the switch as needed and check to see if the cable insulation is damaged.

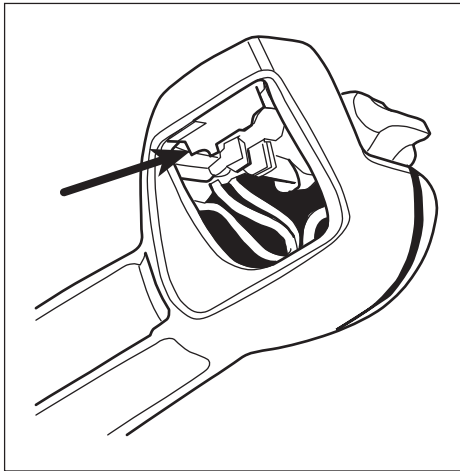

The stop switch can be easily detached with a screwdriver.

The stop switch is easily reached when the cover is removed.

Use a screwdriver pinch the switch's snap fastener inside the throttle.

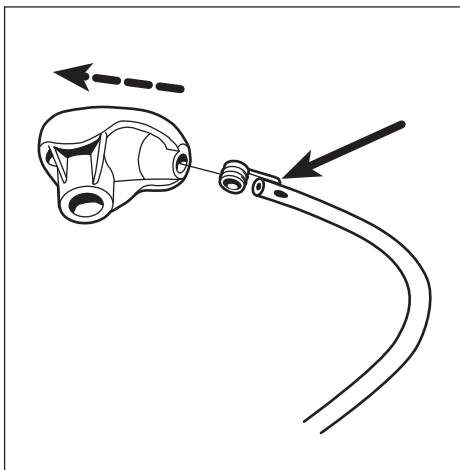

Still no spark?
Check the ignition cable's connection to the spark plug cover.

Still no spark?
Check the spark plug connection.
Remove the spark plug cover and make sure the ignition cable is not damaged. Remove a segment of cable if required to get sufficient contact at the connection coil.

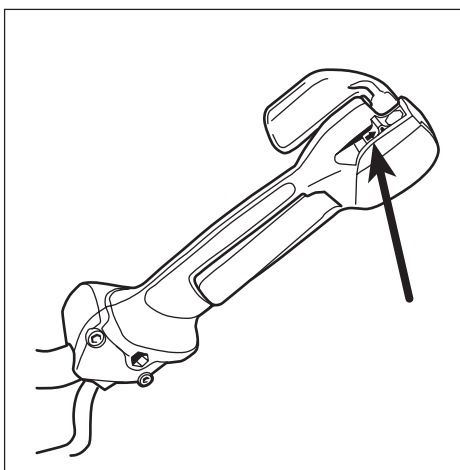

Still no spark?
Check other cables and connections.

Still no spark?
Check other cables and connections for poor contacts (dirt, corrosion, cable breakage and damaged insulation). Make sure that the cables are correctly drawn and lie in the cable grooves. Do not forget to check the cables in the throttle too.
See chapter 3 "Throttle".

Tip!
Use an Ohmmeter in order to easily check if cable breakage has occurred, due to pinching, for example.

2 Electrical system

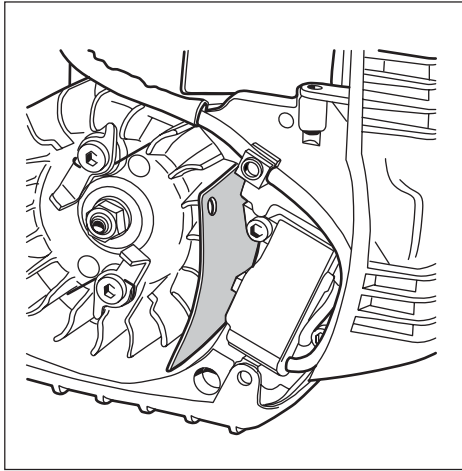

Still no spark?
Check the air gap.

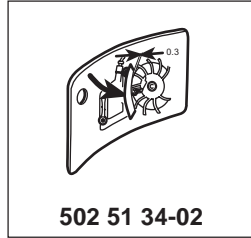

Adjust the air gap.

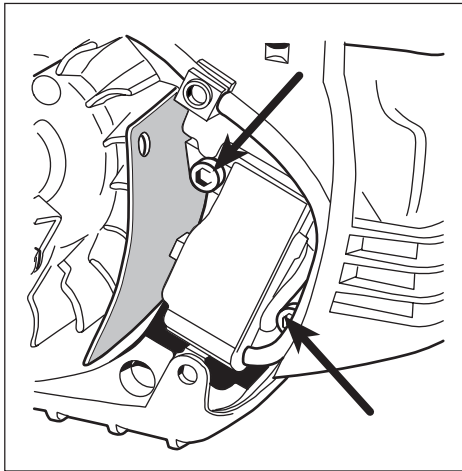

Still no spark?
Check the air gap between the flywheel magnet and the ignition module. The gap should be 0.3 mm.
Use a 502 51 34-02 feeler gauge.

Adjust the air gap as needed to the correct value.

- Loosen the bolts.
- Position the feeler gauge and press the ignition module against the flywheel.
- Tighten the bolts and check the air gap again.

If the spark plug still does not fire, the ignition system should be replaced.

Replacing the spark plug cover

1. Insert the ignition cable through the spark plug cover.
2. Make a hole in the ignition cable for the ignition coil.

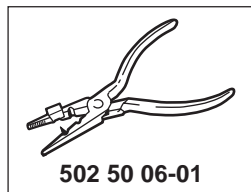

3. Attach the ignition coil to the ignition cable.

Replacing the spark plug cover

1. Lubricate the ignition cable with a little grease and thread it through the spark plug cover.
2. Cut off a bit of the ignition cable (approx. 5 mm) and make a hole in the cable for the ignition coil with the aid of a pair of no. 502 50 06-01 pliers.

3. Attach the ignition coil to the ignition cable and ensure that the wire is folded along the cable.
4. Pull the ignition coil into the spark plug cover.

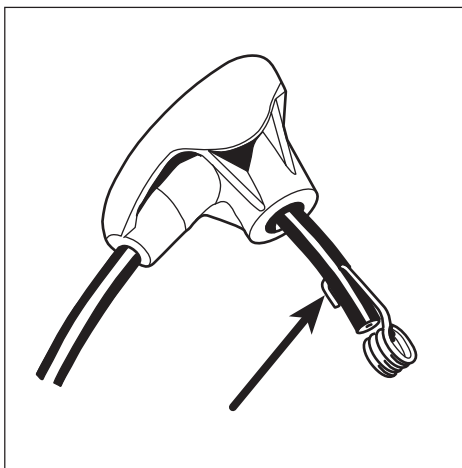
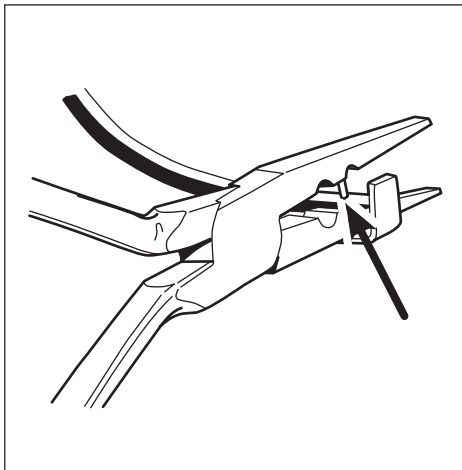

NOTE!

It is important that the tip of the ignition coil hits the centre of the ignition cable to prevent sparking.

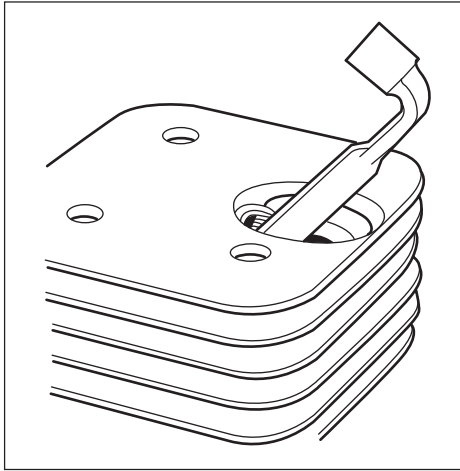

Dismantling

Remove the starter, cylinder cover, and spark plug.

Attach piston stop no. 502 54 15-01.

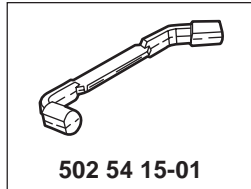

502 54 15-01

Dismantling

Remove the starter, cylinder cover, and spark plug.

Fit piston stop no. 502 54 15-01 in the spark plug hole.

NOTE!

Place the piston stop so it is caught between the piston and the cylinder head. Not so it sticks out into the exhaust port.

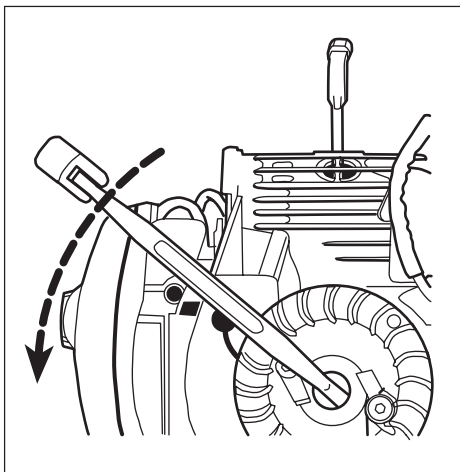

Remove the nut holding the flywheel.

Remove the nut holding the flywheel.

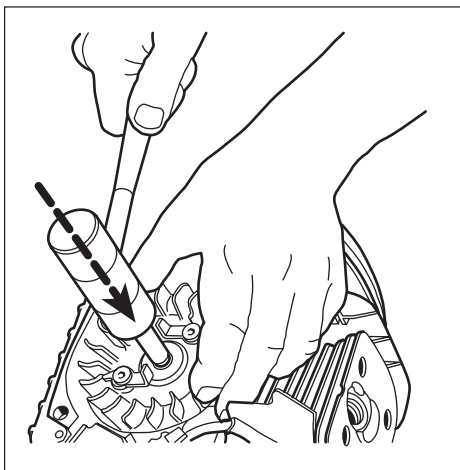

Remove the flywheel.

Remove the flywheel from the crankshaft using punch no. 502 51 94-01. Leave a gap of approx. 2 mm between the punch and the flywheel. Gently knock the punch with a hammer while holding the flywheel with your other hand.

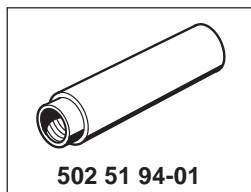

502 51 94-01

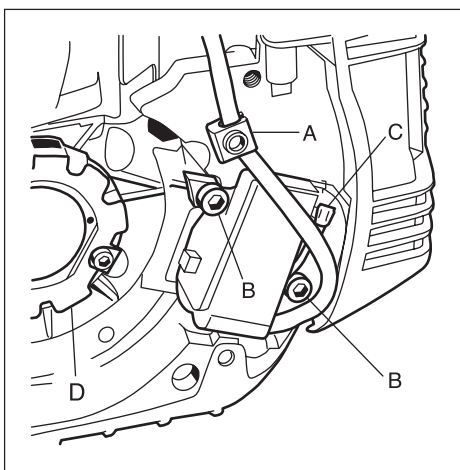

Remove the ignition module and the generator.

Dismantle the ignition module. Remove the ignition cable from the holder (A). Remove both bolts (B). Loosen the short-circuit cable (C) from the ignition module. Remove the generator (D) that supplies power to the heated handles.

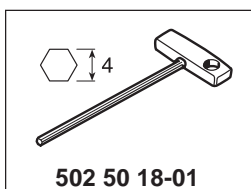

502 50 18-01

Electrical system

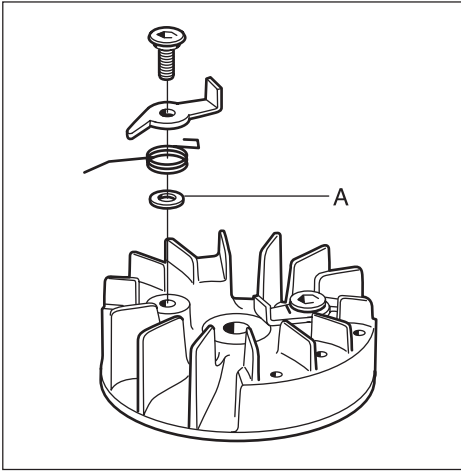

Drive dogs

Remove the bolts.
Remove the hooks and the springs to replace them.
Mind the washer (A) so as not to lose it.
Replace damaged parts.
Assemble in the reverse order.

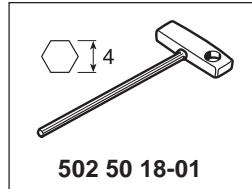

Assembly

Check the key groove in the crankshaft and key in the flywheel. If damaged the components must be replaced.
Attach the ignition module and then the flywheel.
Check the air gap, see page 9.

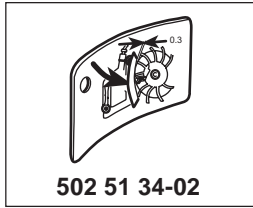

Heated handles

The heating element in the handles consists of ceramic plates. These are self-regulating with regard to temperature. When temperature increases, the resistance in the elements lowers and so does the temperature. So no separate thermostat is needed.

Remove the throttle from the handle.
In order to have access, the bolt that holds the throttle and the cover with the circuit breaker must be removed to reach the electrical cables.

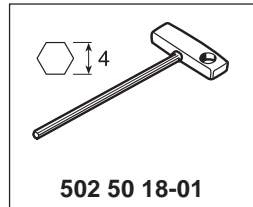

The heating element in the throttle is accessed when the throttle lock is pushed out of the throttle.
Pry off the locking catch and lift out the heating element.

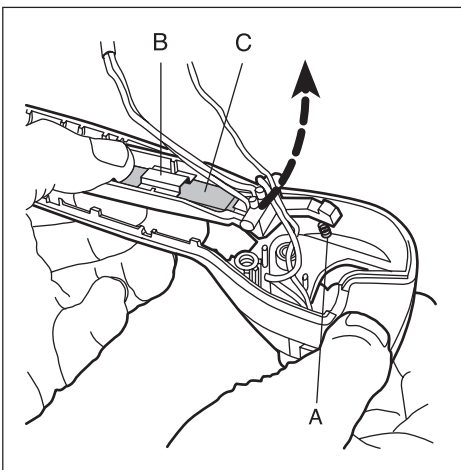
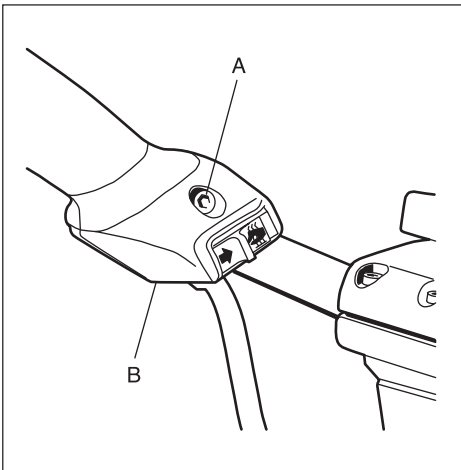
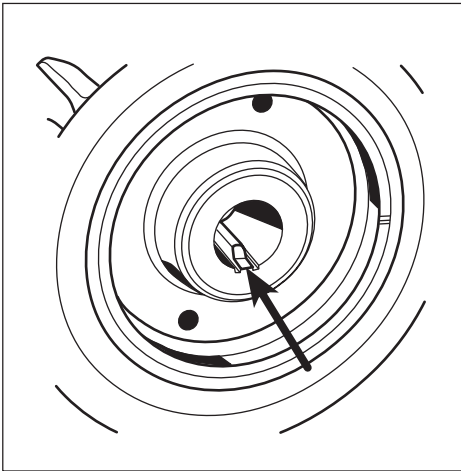

Drive dogs

The drive dogs can be easily replaced if they are damaged.
Remove the bolts, the hooks and the springs.
Mind the washer (A) so as not to lose it.
Replace damaged parts.
Assemble in the reverse order.
Check that the hooks can be turned freely when the bolts are tight.

Assembly

Check that the key groove in the crankshaft is not damaged. If it is, the crankshaft must be replaced.
Attach the ignition module and make sure the short-circuit cable is not trapped.
Check that the key in the flywheel is not damaged. If it is, the flywheel must be replaced.
Attach the flywheel.
Check the air gap, see page 9.

Remove the throttle from the handle.
See also chapter 3 "Throttle".
In order to remove the heating element the bolt (A) that holds the throttle and cover (B) and the heater switch must first be removed (2 bolts).

A heating element is placed in the throttle lock for involuntary throttling. Press the locking catch from the throttle, making sure not to lose the spring (A).
Pry off the locking catch (B) and lift out the heating element (C).

NOTE!

Do not pry off the heating element before the locking catch has been removed. The element can be damaged.

Electrical system

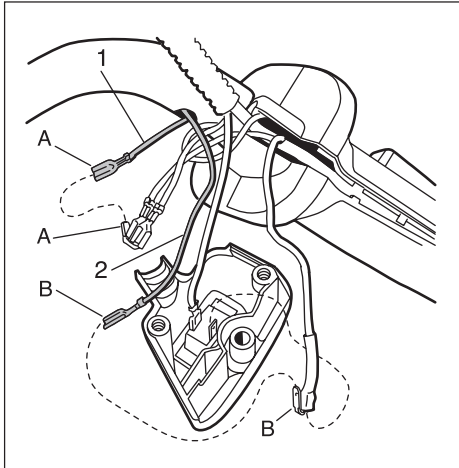

Separate the contacts (A-A) and (B-B). Then extend the cables (A) and (B) with approx. 90 cm long steel wires attached to the contacts.

Separate the contacts (A-A) and (B-B). Then extend the cables (A) and (B) with approx. 90 cm long steel wires attached to the contacts.

This is to make it easier to draw the cables to the new heating element back through the handle.

1 = black

2 = blue

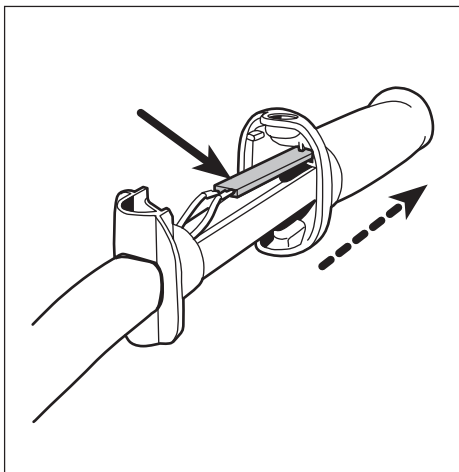

Remove the bolt and pull off the left grip from the handle.

Pull one cable at a time from the handle.

Remove the heating element from the handle with a pair of flat nosed pliers.

Remove the bolt that holds the left grip on the handle.

Pull out handle from the handlebars and then the cables, carefully and one at a time, so that the steel wire does not loosen from the cables.

The heating element is located in a pocket in the outside of the handle. Use flat nose pliers to pull out the heating element from the handle.

NOTE!
Do not pull the cables or their connections. Connections can be easily broken.

Assemble in the reverse order as set out for dismantling.

Wiring diagram

LH = Left handle

RH = Throttle

HC = Heater switch

TT = Triple contact

IM = Ignition module

SC = Short-circuit switch

Gen = Generator

Blu = blue

Bl = black

Re = red

Bl/Blu = black/blue

Use a universal tool when checking wiring and heating elements. Set the instrument to measure resistance to check for open circuits.

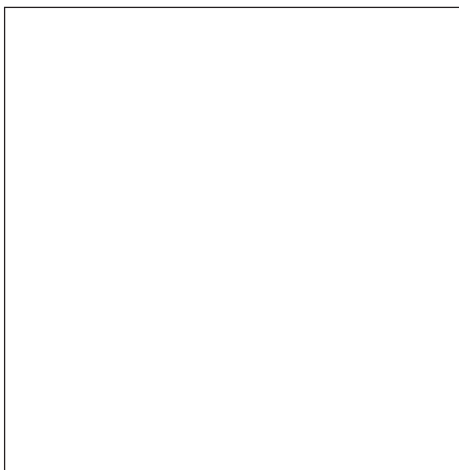
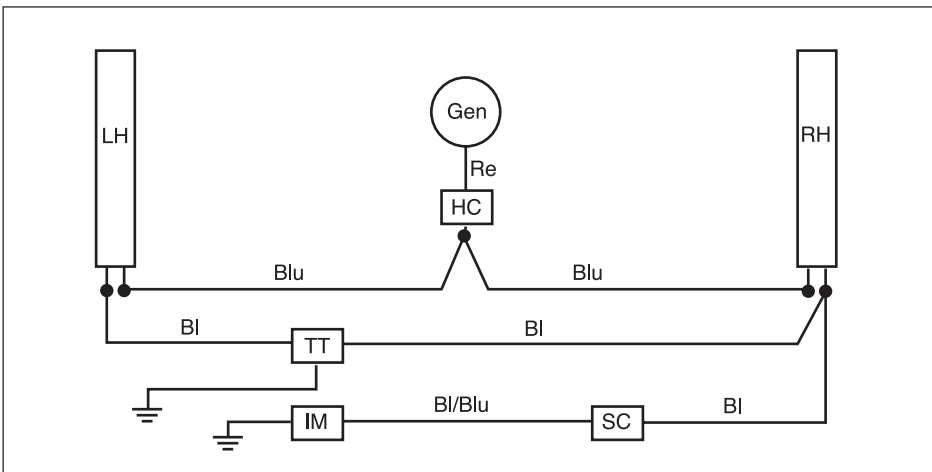

Fuel system

3.

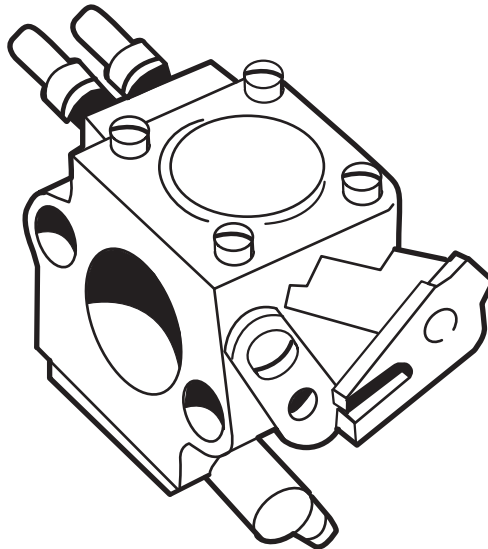

Contents

Air filter	16
Tank venting	17
Fuel filter	17
Fuel pump	18
Carburettor	18
Assembly	24
Carburettor settings	25
Throttle	27

In addition to the fuel tank and carburettor, the fuel system consists of the air filter, fuel filter and tank venting.

All these components interact so that the engine receives the optimal mixture of fuel and air to make it as efficient as possible. Very small deviations in the carburettor setting or a blocked air filter have a large effect on the running and efficiency of the engine.

The carburettor can come from several different manufacturers on our models, but the function and repair methods are essentially the same.

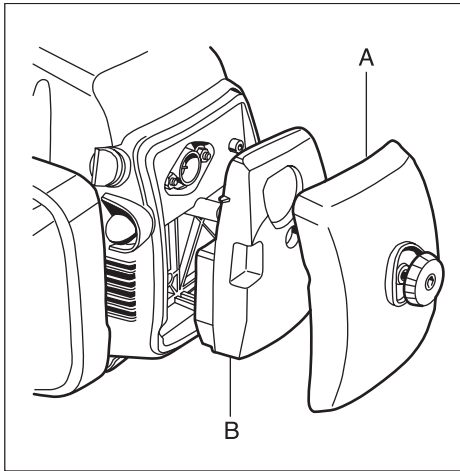

Air filter

Remove the air filter holder.

Air filter

Dismantle the cover (A) and remove the air filter (B).

The nylon filter comes in two models. The standard filter has a mesh size of 80µ. There is also a 44µ unit available. There is also a flock filter, also as an accessory.

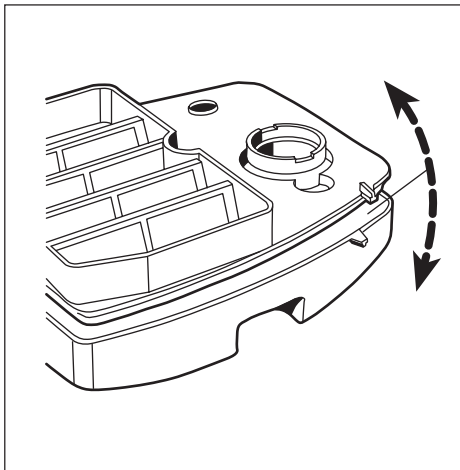

Separate the filter halves and clean the nylon filter in warm soapy water.

The R-variant has a foam rubber filter.

The air filter comes apart. Separate the two halves with a screwdriver.

Clean the filter in warm soapy water. If the filter fabric is damaged the entire filter should be changed.

The R-variant has a foam rubber filter.

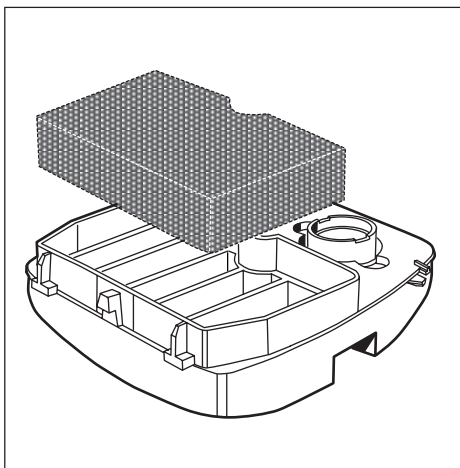

Remove the foam rubber filter and clean it in warm soapy water.

Remove the foam rubber filter and clean it in warm soapy water.



WARNING!

Do not clean not the filter with petrol. Hazardous!

NOTE!

Do not blow the filter clean with compressed air. It can be damaged. Ensure that the filter is dry before refitting it.

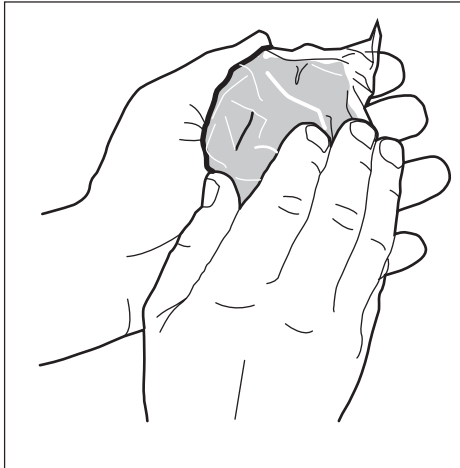

Impregnate the filter with air filter oil.



531 00 60-76

Impregnate the filter with air filter oil.

Tip!

Place the filter in a plastic bag and pour about a tablespoon of air filter oil no. 531 00 60-76 into the bag. Massage the oil into the air filter.

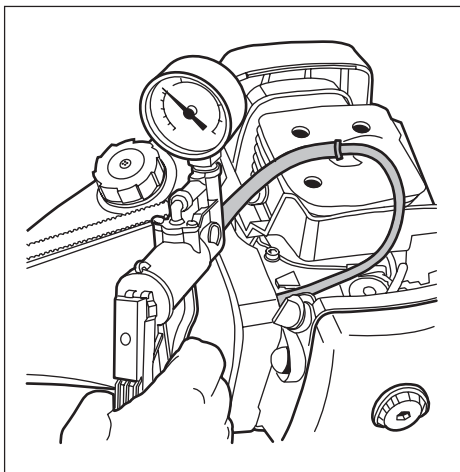

Tank venting

Check that the tank venting valve works correctly.
Replace the fuel cap if the valve is faulty.

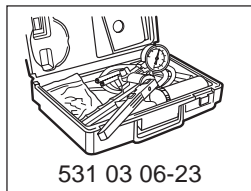

531 03 06-23

Tank venting

Tank venting takes place through the fuel cap and needs to be functional for the engine to work.

- Remove the fuel hose from the carburettor and empty the fuel from the tank.
- Connect the fuel hose to pressure tester no. 531 03 06-23.
- Pump up a pressure and vacuum of 50 kPa (0.5 bar) in the tank.
- The pressure should sink to 20 kPa or return to normal pressure within 45 seconds.

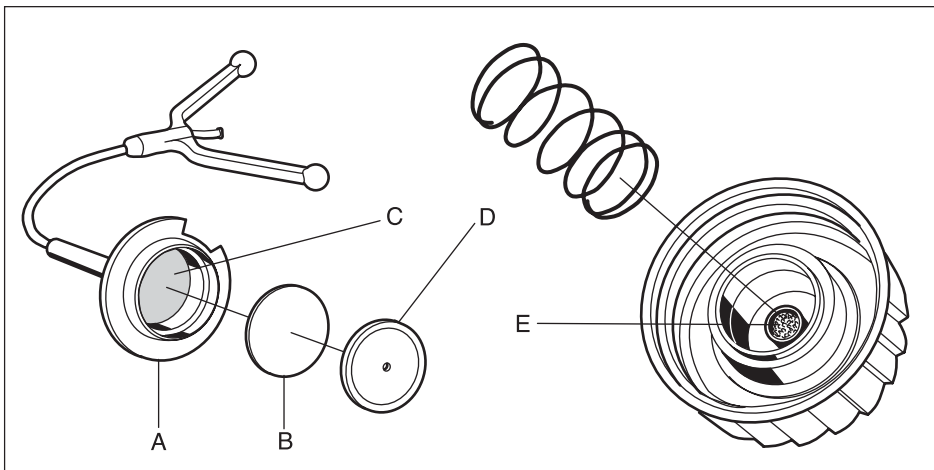

The fuel cap can be taken apart for cleaning.

Use a screwdriver and prise off the housing (A) that contains a rubber diaphragm (B) and a filter (C).

Knock the housing against a tabletop so that the cover (D) over the diaphragm falls off.

Blow the filter (C) clean, and the sintered filter (E), with compressed air and mount the fuel cap in the reverse order to how it was disassembled.

Make sure that the flat surface on the cover (D) is turned towards the diaphragm.

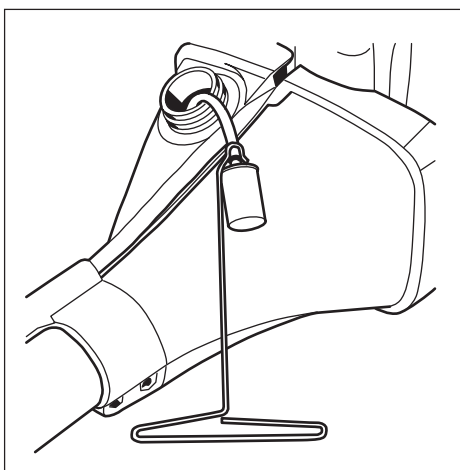

Fuel filter

The fuel filter can be removed through the tank's fill hole.

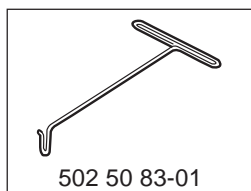

502 50 83-01

Fuel filter

The fuel hose in the tank contains a fuel filter. It is accessible through the fill hole. Pull out the filter with your fingers or with help of tool 502 50 83-01.

NOTE!
The fuel filter can snag under the shaft bushing in the tank. With the aid of a long screwdriver, loosen the filter. Do not pull on the hose, since it can easily be pulled from the filter.

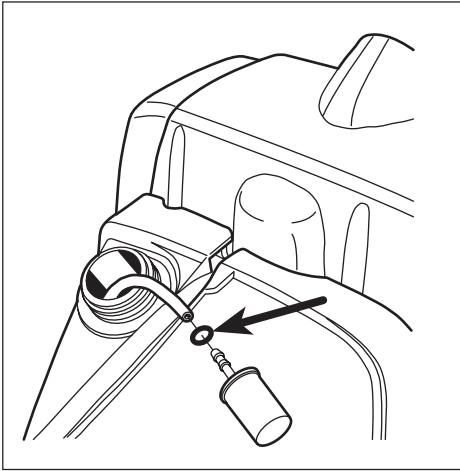

Clean the filter externally if it is not too dirty.
Replace the filter if required.

If the filter is not too dirty, its surface can be cleaned with a brush.
Otherwise it must be replaced.
Check the fuel hose for cracks and leaks.
Make sure that the filter's connection neck is inserted as far as possible into the fuel hose and that the O-ring is sufficiently tight so that the filter cannot slide off the tube.

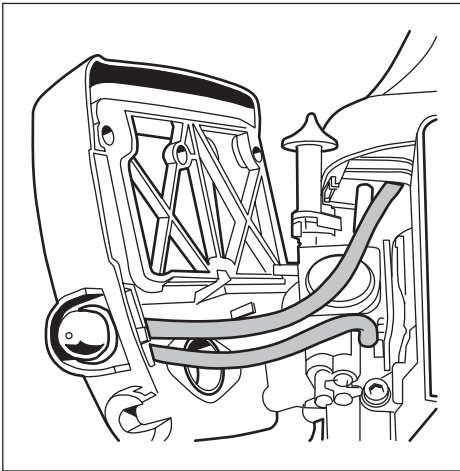

Fuel pump

The fuel pump facilitates cold starts.
The pump cannot be repaired and must be replaced if it stops working.
Note how the fuel hoses are connected to simplify assembly.

Fuel pump

The fuel pump has the task of facilitating the start of the engine when cold.
The pump fills the carburettor with fuel before attempting to start the engine. This also prevents vapour bubbles from blocking the narrow fuel channels.
If the pump does not work it must be replaced.
Note how the fuel hoses are connected to simplify assembly.

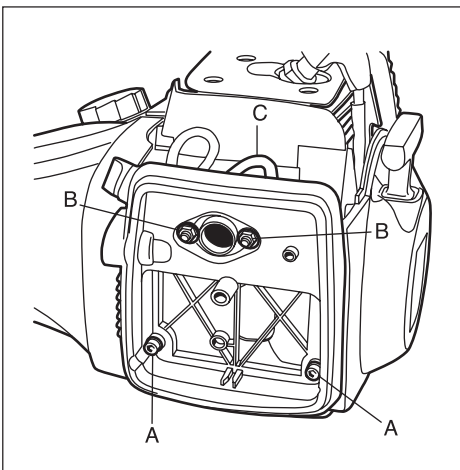

Carburettor

Dismantling
Blow clean the carburettor compartment.
Loosen the bolts (A) and remove the nuts (B).
Remove the fuel hose (C) and fold the filter holder aside.

Carburettor

Dismantling

1. Remove the carburettor cover and blow the carburettor compartment clean with compressed air.
2. Loosen the bolts (A).
3. Remove the nuts (B).
4. Remove the fuel hose (C) from the carburettor and the filter holder.

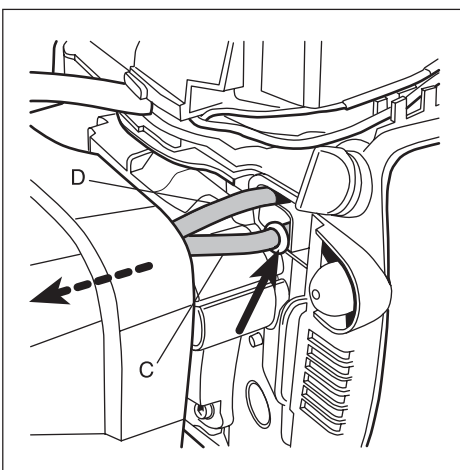
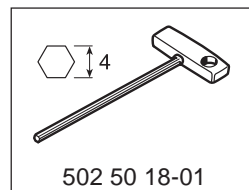
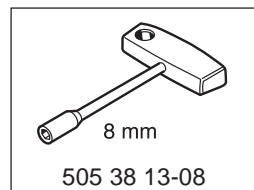

Move the fuel tank so far forward that the fuel hoses (C) and (D) can be removed.

5. Move the fuel tank so far forward that the fuel hose (C) becomes accessible.
Move the O-ring back and remove the hose from the nipple.
Also remove the fuel hose (D) from the nipple on the tank.

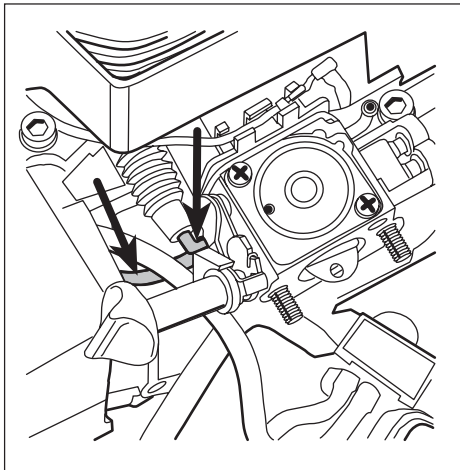

Remove the throttle cable and fuel hose from the carburettor.
Remove the carburettor.

Remove the throttle cable from the carburettor's lever arm using flat nose pliers.
Pull off the fuel hose and remove the carburettor.

Tip!

Open the fuel cap to avoid fuel spillage caused by any excess pressure.
Attach the fuel hose to the return nipple.

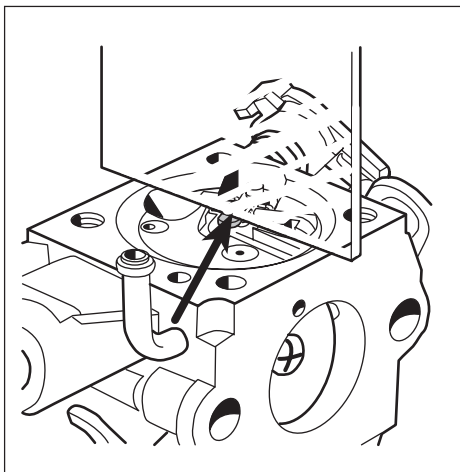

The carburettor is made by Zama.
Design, function and servicing correspond with the Walbro carburettor.

Default carburettor settings:

- H = 1 revolution open
- L = 1 revolution open

The carburettor needles are fitted with movement limiters (caps).

The carburettor is made by Zama.
It has the same design and function as the Walbro carburettor, which means that servicing is also carried out in the same way.

The lever arm should lie flush with the carburettor housing's contact face.

Default carburettor settings:

- H = 1 revolution open
- L = 1 revolution open

The carburettor needles are fitted with movement limiters (caps).

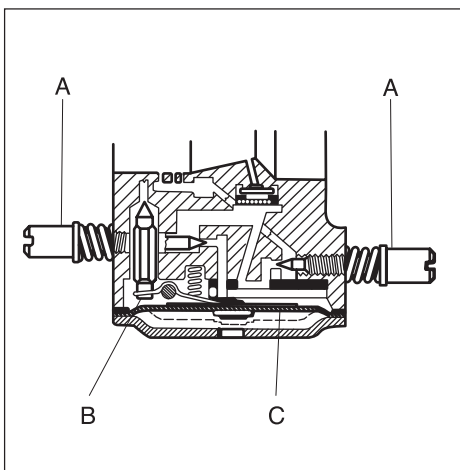

The carburettor's design
The carburettor can be divided into three different functional units: the metering unit, the blending unit, and the pump unit.

The metering unit

The needles and the fuel control functions are located here.

The carburettor's design
The carburettor can be divided into three different functional units: the metering unit, the blending unit, and the pump unit.

The metering unit

The needles (A) and the fuel control functions are located here.
The needle valve (B) and control diaphragm (C) are vital to the carburettor's function.

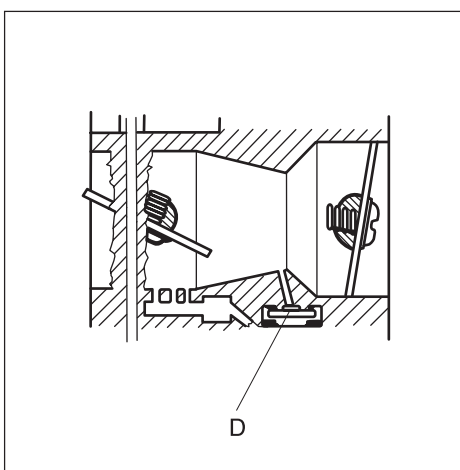

The blending unit

Fuel and air are mixed here.

The blending unit

In this section of the carburettor fuel and air are mixed in the proper proportions.

The choke and throttle valves are placed here.

In the middle of the venturi (narrowest part of the throughput) the main jet (D) is found.

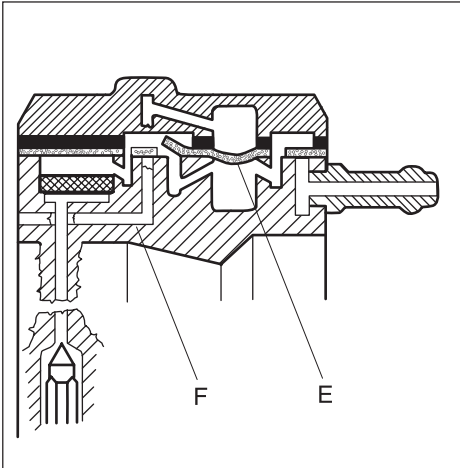

The pump unit

Pumps fuel from the tank to the carburettor.

The pump unit

This is where the pump diaphragm (E) that pumps fuel from the tank to the carburettor's measuring unit is found.

The diaphragm is affected by pressure variations in the engine's crankcase via an impulse channel (F).

If the channel is blocked, by grease or a wrongly facing gasket, for example, the pump unit does not function and the engine cannot be started.

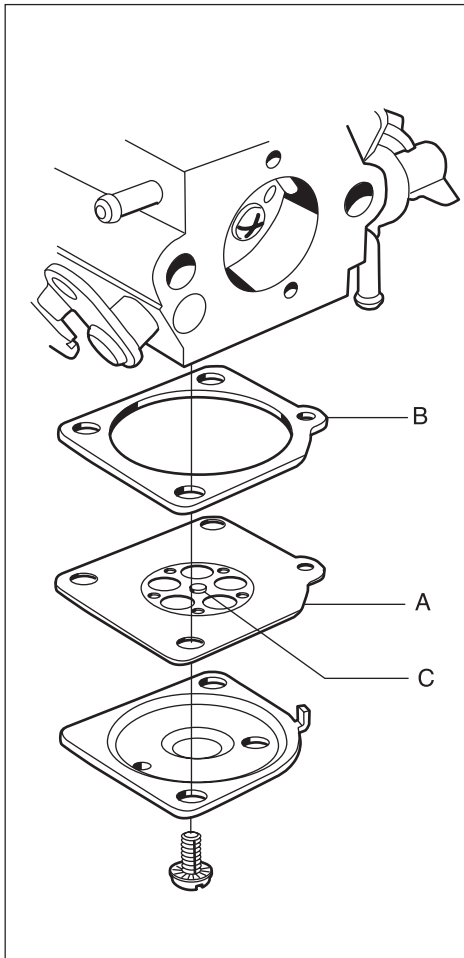

Dismantling the carburettor

Remove the control diaphragm and check for damage.

Replace if required.

Dismantling the carburettor

Carefully remove the control diaphragm (A) and gasket (B).

Check the diaphragm for holes and wear on the pin (C).

Replace the diaphragm if required.

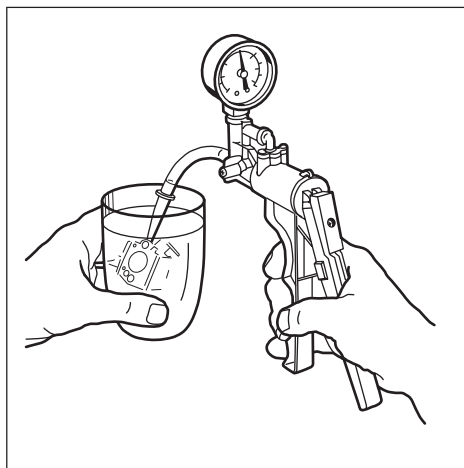

Pressure test the metering unit.

Connect pressure tester 531 03 06-23 to the fuel hose nipple.

Lower the carburettor in a vessel with petrol in order to discover any leaks more easily.

Test the pressure at 50 kPa.

No leakage is permitted.



531 03 06-23

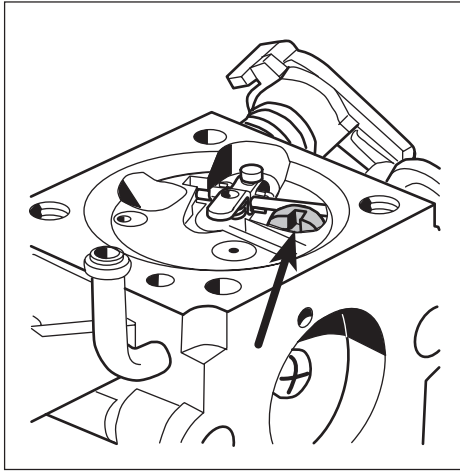

In the event of leakage – remove the needle valve.

In the event of leakage – remove the needle valve.

Loosen the bolt and remove the lever arm, axle, needle valve and spring.

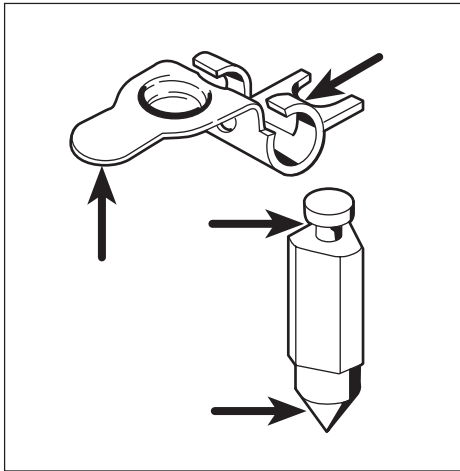

Check the needle valve and the lever arm for damage or wear.

Check the needle valve for damage on the tip and in the lever arm groove.

Replace damaged components with new ones.

Check the lever arm for damage to the groove for the needle valve and wear on the mounting points towards the control diaphragm.

Replace damaged components with new ones.

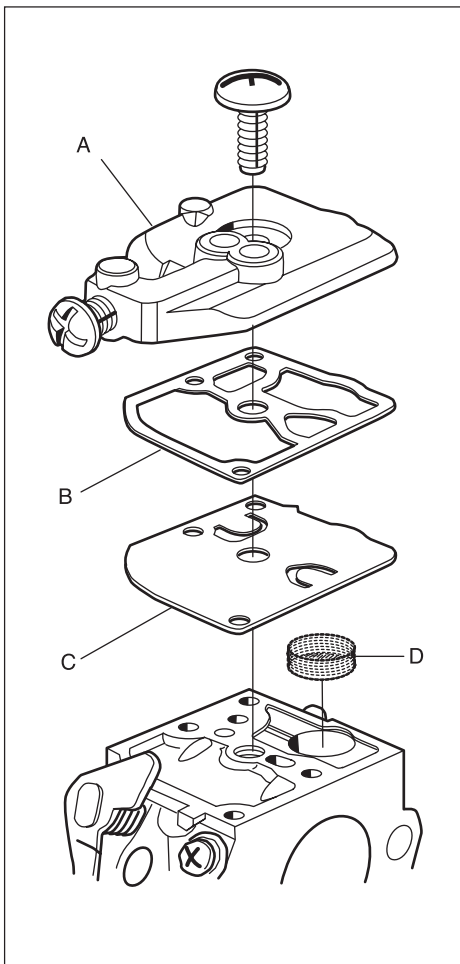

Remove the pump diaphragm.
Check the diaphragm for damage.

Remove the bolt holding the cover over the pump diaphragm.

Remove the fuel screen and clean it or attach a new one.

Lift off the cover (A), the gasket (B) and the diaphragm (C).

Check the diaphragm for damage to the valve tongues. If the valve tongues are bent, the pump will not function in a satisfactory manner.

Hold it up to a light as well to discover any holes in the material.

Carefully remove the fuel screen (D), using a needle for example. Clean or replace the fuel screen.

NOTE!

During assembly the pump diaphragm should lie closest to the carburettor housing.

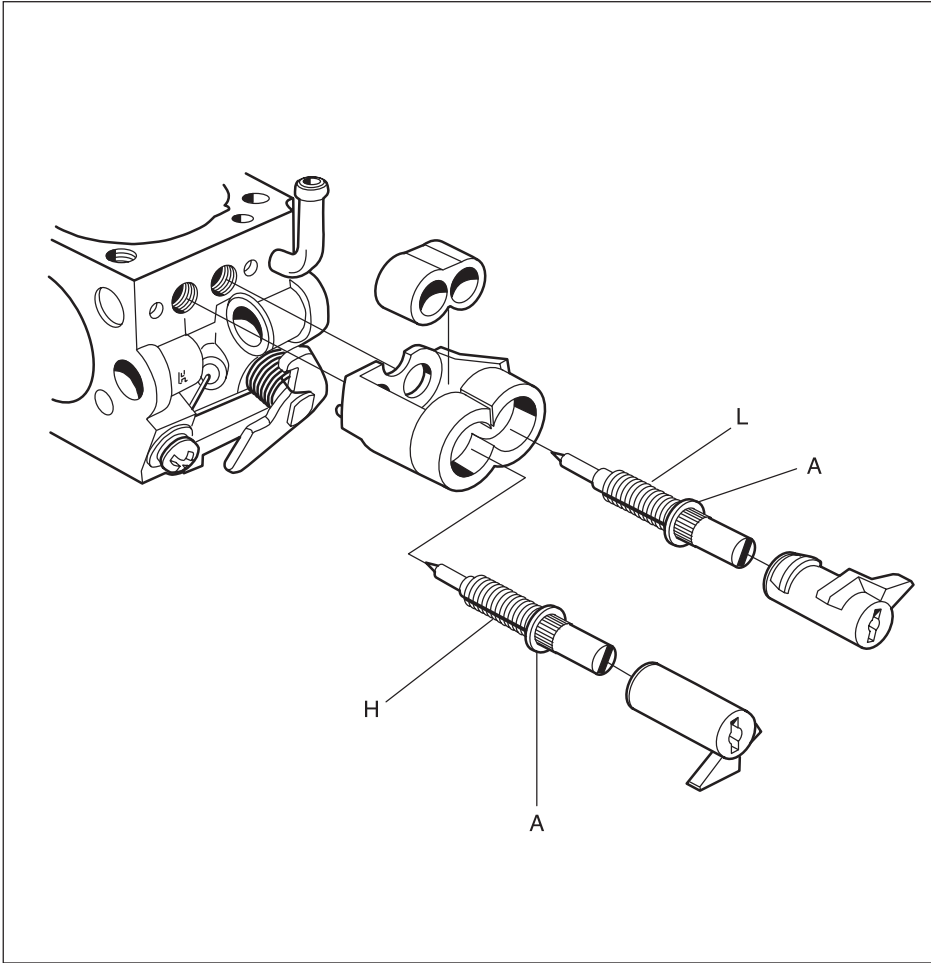

Remove the movement limiters from the jet needles using flat nose pliers.
Unscrew the jet needles.
Do not lose the small washers (A)!
Lift off the plastic and rubber guides.

NOTE!
Note how the jets are positioned.
(For example, the H-needle is a little shorter than the L-needle).

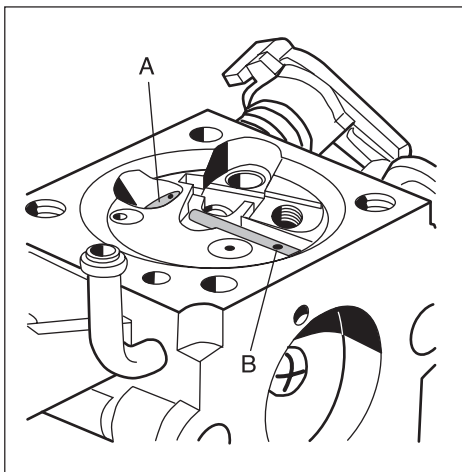

Dismantle the main jet (A) and the plug (B).

Press out the main jet (A) with a suitable punch.

Remove the plug (B).

Carefully drill a small hole (Ø 2 mm) in the plug and pry it up with a pointed object.

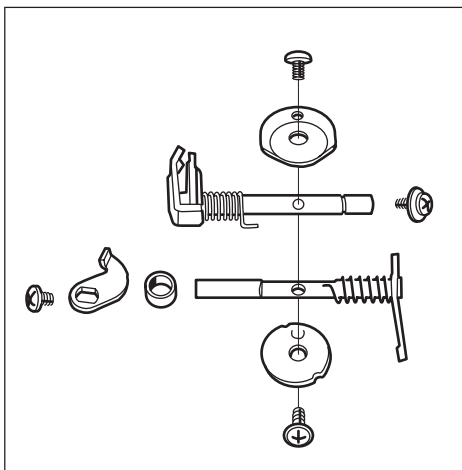

Check valves and dampers for wear.
Replace if required.

Remove the valves and dampers. If these components are worn, idling is disrupted.

Always replace the valves and dampers at the same time.

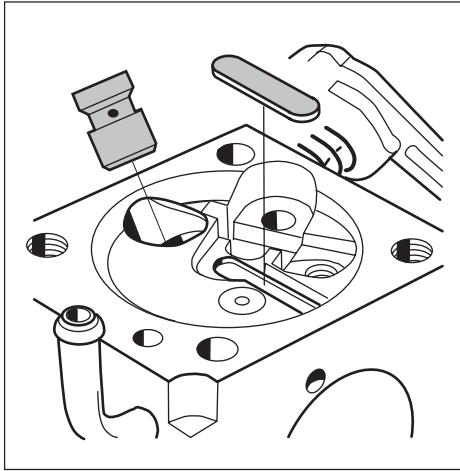

Assembling the carburettor

Blow the carburettor housing clean.
Fit a new plug.
Fit a new main jet.

Assembling the carburettor

- Blow all channels in the carburettor compartment clean
- Mount a new plug.
Use a suitable punch to get a completely tight seal.
- Press in a new main jet.

- Mount the valves and dampers.

Tip!

Any numbers on the valves should be able to be read from the outside.

Replace the fuel screen if it is damaged or cannot be cleaned.

Place the pump diaphragm closest to the carburettor housing. Then the gasket and cover and the other components in reverse order of removal.

NOTE!
Check that the valves are turned correctly and that they close completely and tightly in the closed position.
Use Loctite on the valve screws.

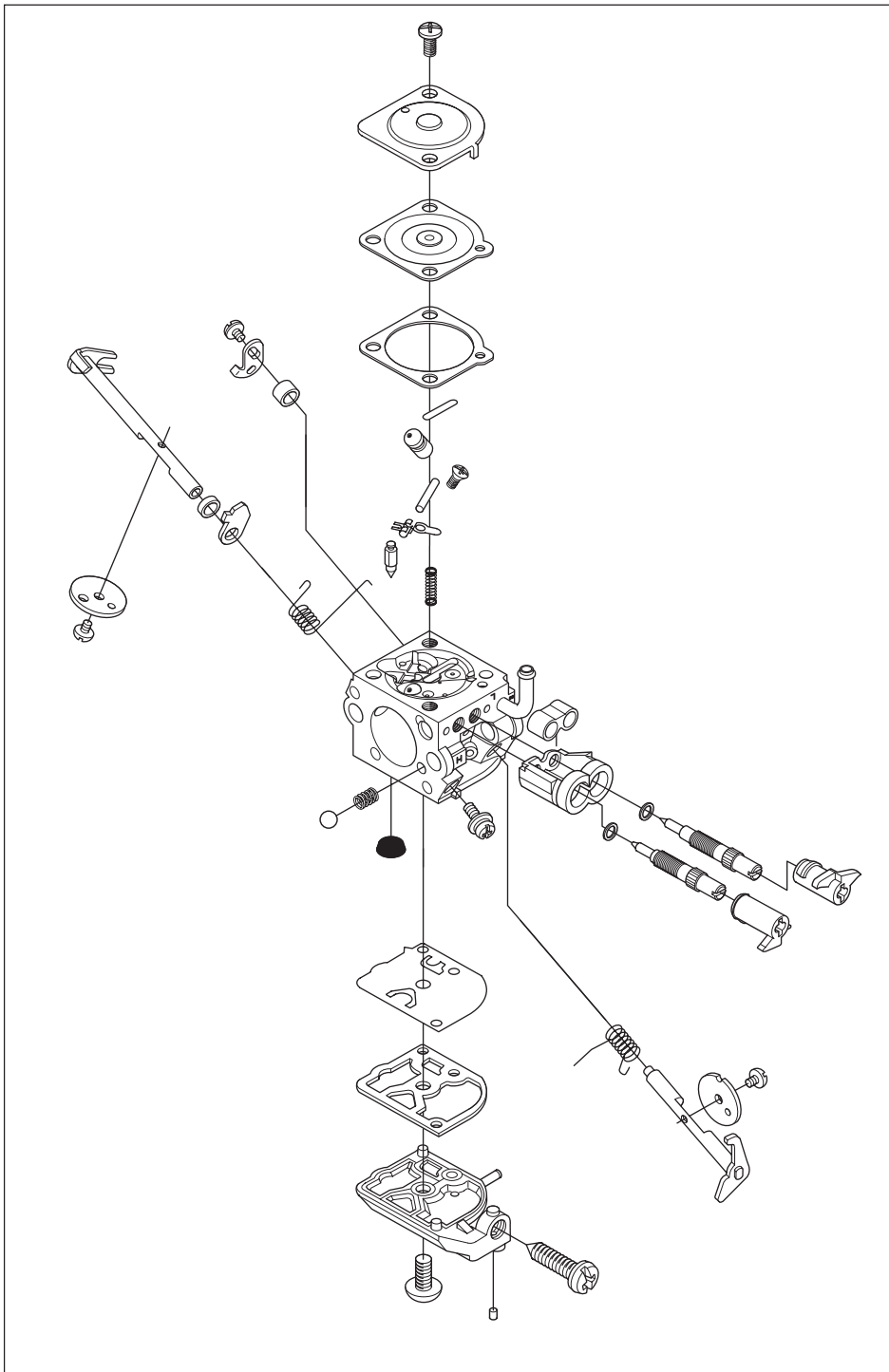

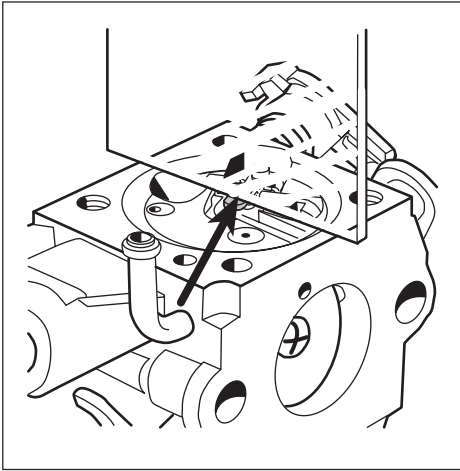

Attach the various parts of the measuring unit in the reverse order as set out for dismantling.

Attach the various parts of the measuring unit in the reverse order as set out for dismantling.

The lever arm should lie flush with the carburettor housing.

Too high setting = too much fuel.

Too low setting = too little fuel.

NOTE!

The H-needle is a little shorter than the L-needle.



Check that the carburettor is sealed. No leakage is permitted at 50 kPa.

Connect pressure tester 531 03 06-23 to the fuel intake on the carburettor.

Pump up the pressure to 50 kPa.

Lower the carburettor in a vessel with petrol in order to discover any leaks more easily.

No leakage is permitted.



531 03 06-23

Attach the control diaphragm and cover.

Place the gasket on the carburettor housing and then the control diaphragm.

Check that the air hole in the cover is open and screw the cover on.

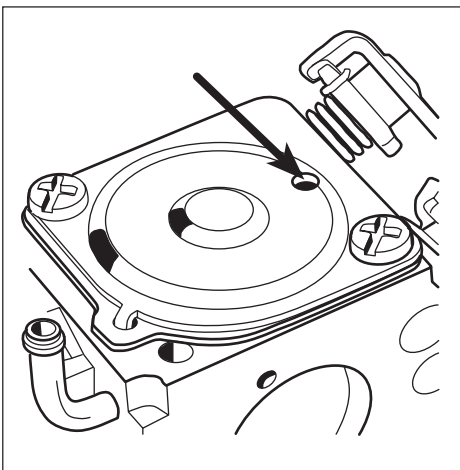

Assembly

Slide the carburettor into place and connect the fuel hoses.

Make sure that they do not get pinched.

Connect the throttle cable to the carburettor.

Assembly

Slide the carburettor into place.

Connect the fuel hose (A) to the carburettor.

Connect the fuel hose (B) to the carburettor and make sure that it is in the groove (C).

Place the filter holder in place and make sure that the fuel hose (D) is under the carburettor and is not pinched.

Connect the throttle cable (E) to the carburettor.

Screw down the filter holder and attach the air filter.

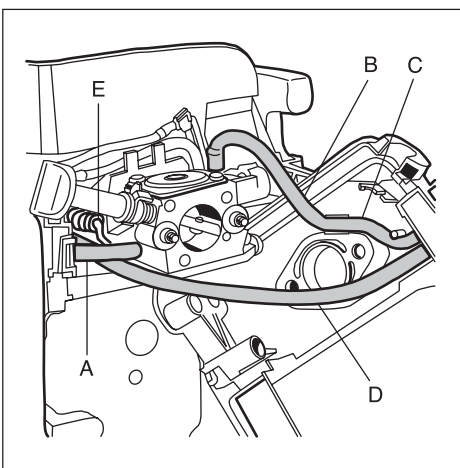

NOTE!

Check carefully that the fuel hoses are not bent or pinched when the fuel tank is pushed back into place against the engine body.

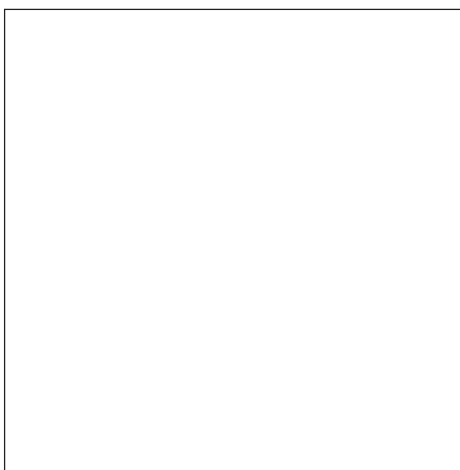
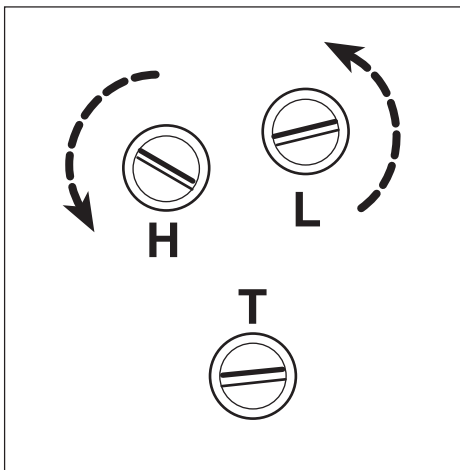
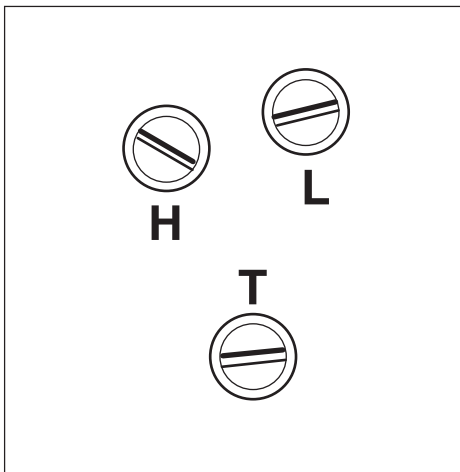
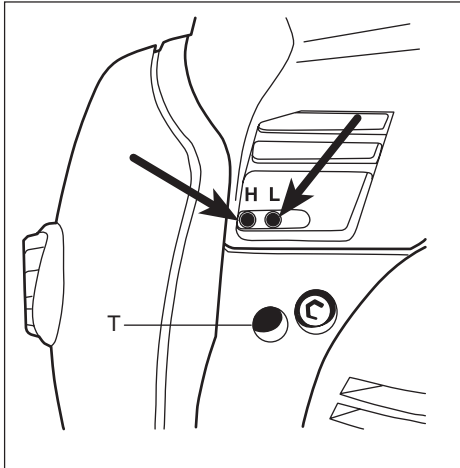

Carburettor settings

WARNING!
 When testing the engine in connection with carburettor adjustment, the clutch and clutch cover must be mounted together with the shaft and angle gear under all circumstances. Otherwise there is a risk of the clutch becoming loose resulting in serious personal injury.

Function

The carburettor has the task of supplying a combustible fuel/air mixture to the cylinder.

The amount of this mixture is controlled by the throttle.

The mixture's composition of fuel and air is controlled by means of the adjustable "H" and "L" needles.

The needles must be correctly adjusted in order for the engine to give maximum power at different speeds, run steadily while idling and to react quickly when accelerating.

The setting of the carburettor can vary a little depending on the humidity, temperature and air pressure.

L = Low speed needle

H = High speed needle

T = Idle adjustment screw

- The fuel quantity in relation to the air flow permitted by the throttle opening is adjusted by the L and H jets. Turning the needles clockwise gives a leaner fuel mixture (less fuel) and turning them anticlockwise gives a richer fuel mixture (more fuel). A leaner mixture gives higher revs while a richer mixture gives less revs.
- The T-screw regulates the position of the throttle while the engine is idling. Turning the screw clockwise gives a higher idling speed while turning it anticlockwise gives a lower idling speed.

Basic setting

The carburettor is set to its basic setting when test run at the factory. The basic setting is "richer" than the optimal setting (fast idle speed is 600–800 rpm under the recommended max. speed) and should be kept during the engine's first working hours. Thereafter the carburettor should be fine tuned.

The default setting is:

H = 1 revolution open

L = 1 revolution open

Fine adjustment

Fine adjustment of the carburettor should be carried out after the engine has been "run-in".

- The air filter should be clean and the cylinder cover fitted when all adjustments are made.

First adjust the L-needle, then the H-needle and finally the idling speed's T-screw.

Idling speed = 2,800 rpm.

- Since the ignition system is limited in terms of rpm, the pre-programmed fast idle speed (12,500 – 13,500 rpm) cannot be exceeded even if the H-needle is screwed inwards. The risk in this case is still that the engine breaks down as a result of a too lean fuel/air mix.
- At full throttle, the H-needle shall have a setting so that the engine is almost splutters.

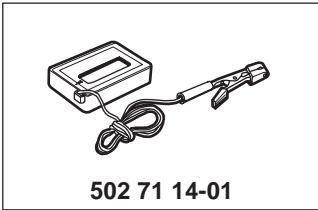

When checking the speed on a trimmer no part of the cord should be extended.

Use the 502 71 14-01 tachometer to check the speed.

- Carefully screw in (clockwise) the L- and H-jets until they bottom. Now screw out (anticlockwise) the needles 1 turn. The carburettor now has the setting H = 1 and L = 1.

Use special screwdriver 501 60 02-03.

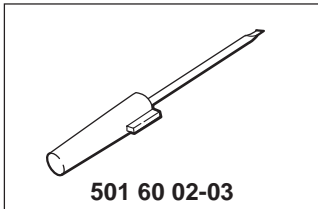

- Start the engine and run warm for 10 minutes.

Low speed jet L

Find the highest idling speed by slowly turning the low speed needle clockwise and anticlockwise. When the highest speed has been found, turn the L-needle 1/4 turn anticlockwise.

High speed jet H

The high-speed H-needle affects the engine's power and speed. A too lean H-needle setting (H-needle screwed in too far) gives too little fuel to the engine resulting in damage to the engine.

Run the engine at full throttle for about 10 seconds. The H-needle is set correctly when the engine "splatters" a little.

If the muffler smokes heavily, at the same time as the engine "splatters" a great deal, the setting is too "rich". Turn the H-needle clockwise until you find the setting that sounds right.

NOTE!

A tachometer should always be used to find the optimal setting.

The recommended max. speed must not be exceeded.

Idling speed T-screw

Let the engine idle for about 30 seconds or until the speed has stabilised. Adjust the idling speed T-screw until the engine idles without stopping.

- Turn the screw clockwise if the engine stops.
- Turn the screw anticlockwise to lower the speed.

Correctly adjusted carburettor

A correctly adjusted carburettor means that the engine accelerates without hesitation and it "splatters" a little at full throttle.

- A too lean adjusted L-needle can cause starting difficulties and poor acceleration.
- A too lean adjusted H-needle results in lower power, poor acceleration and/or damage to the engine.
- A too rich setting of the "L" and "H" needles give acceleration problems or a too low working speed.

NOTE!

If the cutting equipment rotates while idling the T-screw should be turned anticlockwise until it stops.

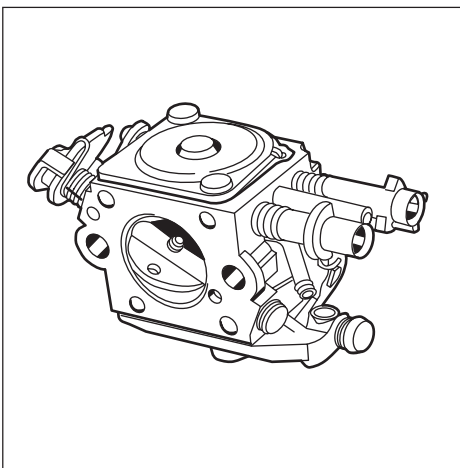

Carburettors in E-Tech and CARB-EPA designs (CARB II-EPA II only applies to USA and Canada)

On these types of carburettor the H- and L-needles can be adjusted within extremely tight limits, to among other things, comply with the stringent demands with regard to the hydrocarbon and nitrogen oxide content in the exhaust fumes.

The carburettor needles on these carburettors are fitted with plastic sleeves with movement limiters, so-called caps.

To carry out adjustment when replacing needles or the entire carburettor the engine must be under load. This is achieved by fitting a Trimmy Fix with the specified length and diameter of trimmer cord. Consequently, the stated speed will be much lower than with "normal" carburettor adjustment when the engine may run freely.

After replacing the needles or the entire carburettor on a CARB-EPA approved engine, adjustment must be carried out according to the instructions below.

The combiguard or trim guard must be fitted when adjusting the H-needle.

Carburettor adjustment 345RX/FX

Adjusting the L-needle

1. Mount the Trimmy Fix (4 wires) and use 3.3 mm smooth cord. The cord length should be 160 mm measured from the end of the cord to the cord bushing on the trimmer head.
2. Run the engine warm for about 5 minutes.
3. Turn the L-needle so that the highest speed is attained.
4. If the speed exceeds 3,700 rpm, reduce it with the aid of the idling speed's T-screw (T) and carry out a new adjustment in accordance with point 3.
5. Then turn the L-needle anticlockwise so that the speed drops by 300 rpm.
6. Then adjust the idling speed to 2,800 rpm by turning the T-screw.
7. When mounting the plastic sleeve on the L-needle, the needle is turned a quarter-turn anticlockwise once the optimal setting has been made and the plastic sleeve is mounted so that the needle cannot be turned anticlockwise. Then turn the L-needle back a quarter-turn.

Carburettor adjustment 345RX/FX

Adjusting the H-needle

1. Mount the Trimmy Fix (4 wires) and use 3.3 mm smooth cord. The cord length should be 160 mm measured from the end of the cord to the cord bushing on the trimmer head.
2. Run the engine warm for about 5 minutes.
3. Turn the H-needle so that the highest speed is attained.
4. Reduce the speed by 400 rpm by turning the H-needle anticlockwise. Mount the plastic sleeve on the H-needle so that it cannot be turned anticlockwise.
5. Then increase the speed by 200 rpm by turning the H-needle clockwise.

NOTE!

If the cutting equipment rotates while idling the T-screw should be turned anticlockwise until it stops rotating.

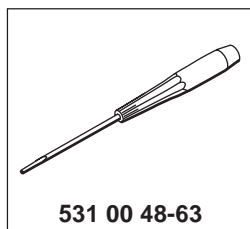
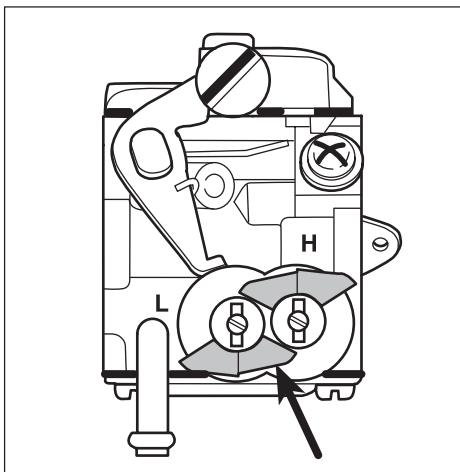

Carburettor needles with Zama "caps".

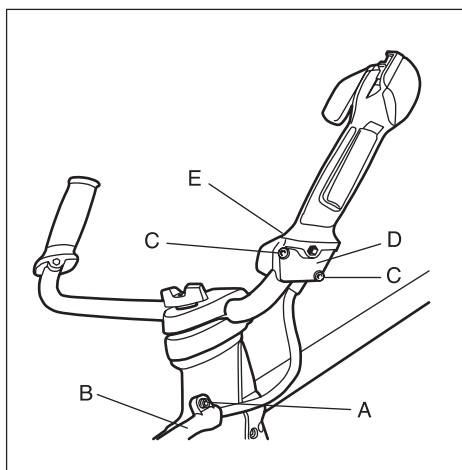

Throttle

Disassemble the cable protector (B), the cover (D) and the throttle from the handle.

Remove the bolts and separate the two halves of the throttle.

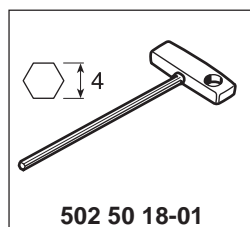

Throttle

Remove the bolt (A) and cable protector (B).

Remove the two bolts (C) and the cover (D).

Remove the bolt (E) that attaches the throttle to the handle and remove the throttle.

Remove the bolts and separate the two halves of the throttle.

Fuel system

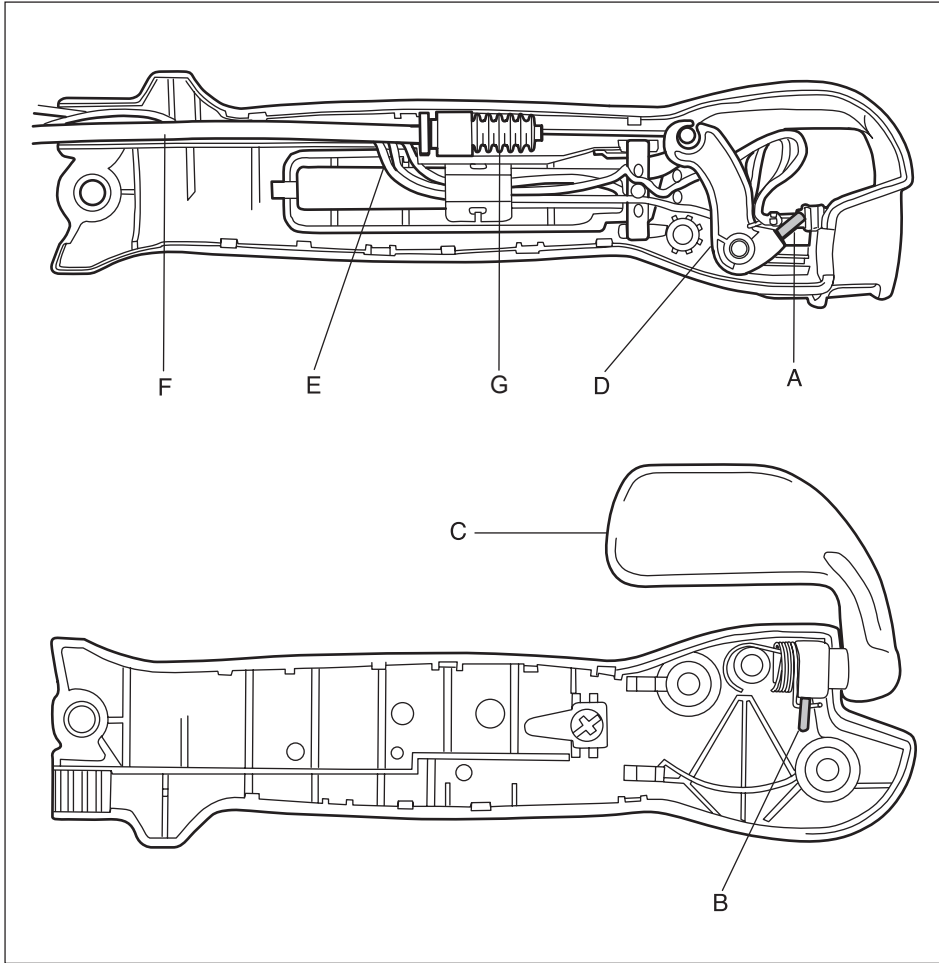

Check for wear on pins (A) and (B).
 Replace the throttle control (C) and lever arm (D) if necessary.
 Check that the cables are properly pressed into the cut-outs (E) and that the throttle cable (F) is in the right groove.
 If necessary, attach it with silicon adhesive in order to facilitate assembly.
 Check that the protective bellows (G) are whole and that they are correctly mounted over the ball on the cable.

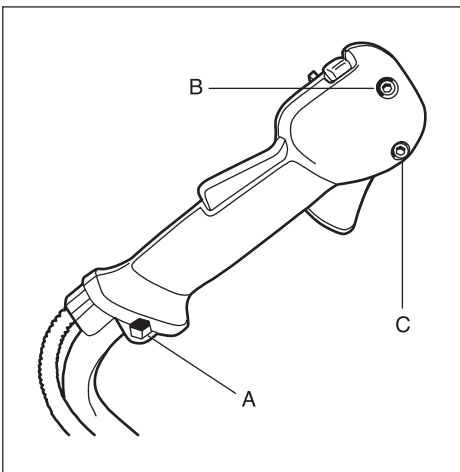

Remove the bolt (A) and remove the throttle from the handle.
 Remove bolts (B) and (C).
 Separate the halves of the throttle.

Remove the bolt (A) that attaches the throttle to the handle.
 Be careful not to lose the nut.
 Remove the throttle and remove bolts (B) and (C).
 Carefully separate the two halves of the throttle.

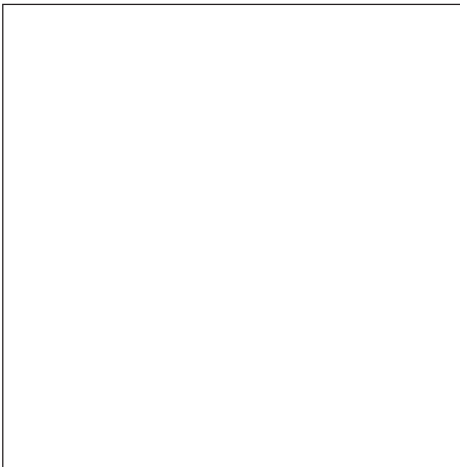

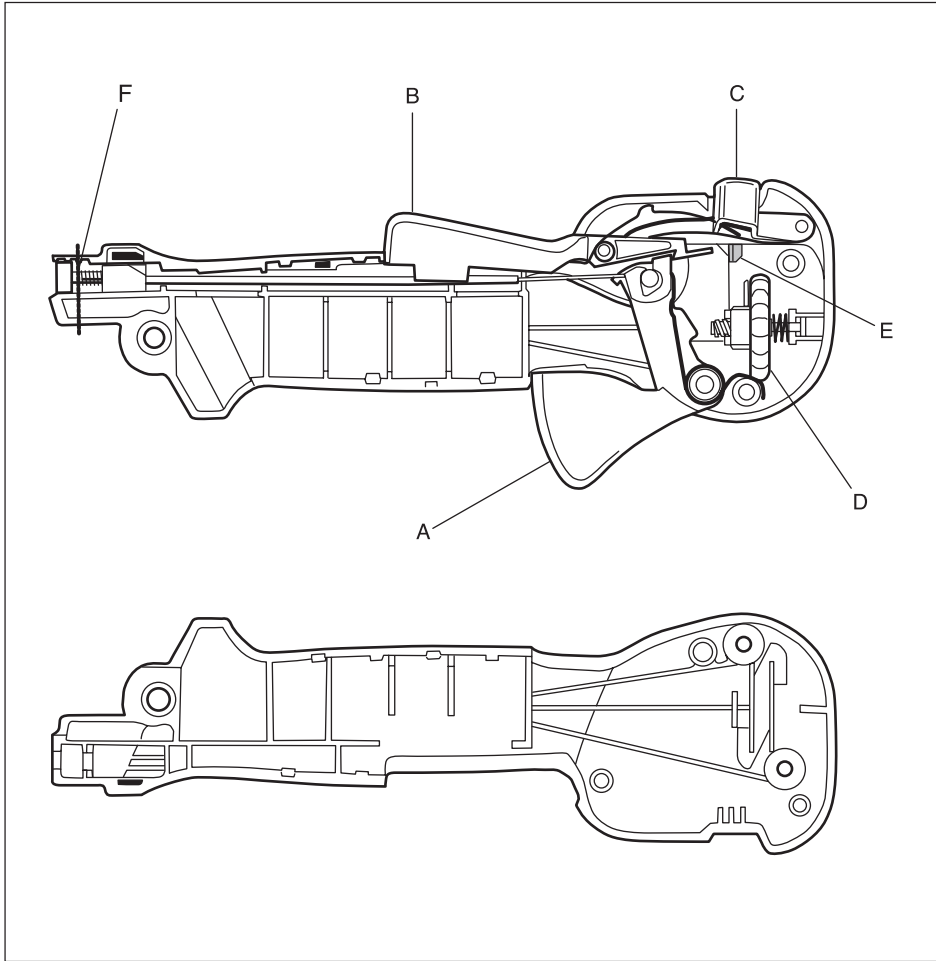

Disassemble the throttle control (A), the lock to prevent accidental throttle operation (B), the start throttle lock (C) and the throttle stop (D) in order to check if replacement is necessary.

The stop switch can also be disassembled now, and replaced if necessary. Use a screwdriver to press the stop switch's wing locks (E).

Tip!

Reassembly of the throttle easier if a thin steel wire is wrapped around the handle and bolt (F) in order to hold the throttle cable and short-circuit cables in place.

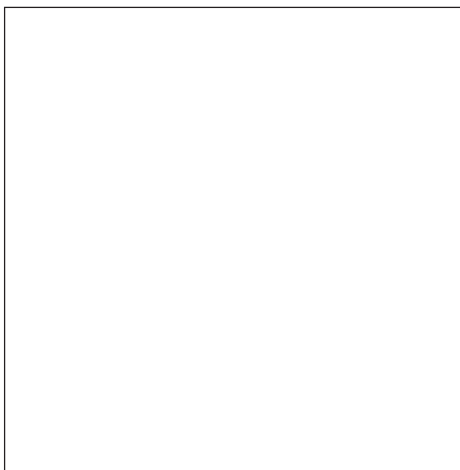
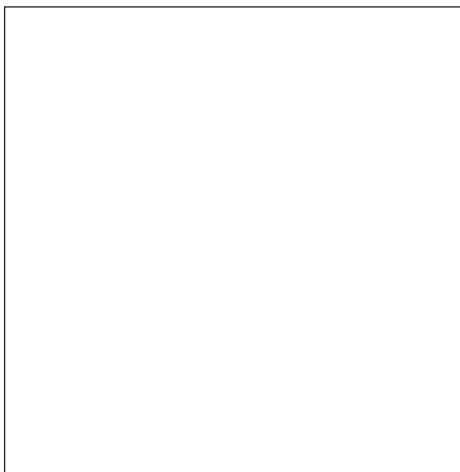

Centrifugal clutch

4.

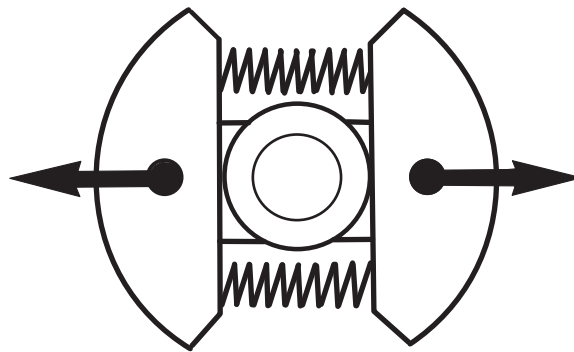

Contents

Dismantling	_____	30
Assembly	_____	32
Clutch drum	_____	32

4 Centrifugal clutch

The centrifugal clutch has the task of transferring the power from the engine to the cutting equipment's drive axle. As the name implies, it works according to a centrifugal principle.

This means the clutch's friction shoes are thrown outwards towards the clutch drum at a certain engine speed. When the friction against the drum is sufficiently great it drives the drive shaft at the same speed as the engine.

Some slipping occurs between the clutch and the clutch drum when accelerating as well as in the reversed situation when the cutting equipment jams. Thereby preventing abnormal load changes on the crankshaft.

The engagement speed has been carefully tested so that the engine can idle without the cutting equipment's drive shaft rotating.

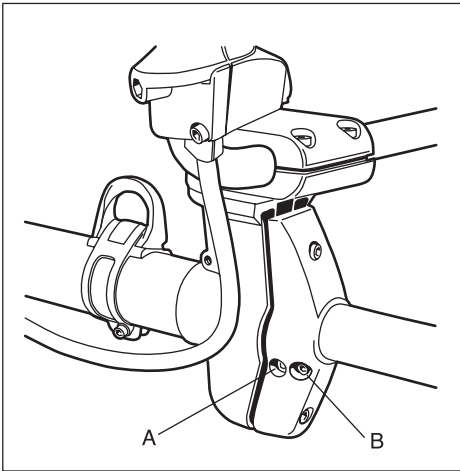

Dismantling

Dismantle the cable protector, loosen bolts (A) and (B).

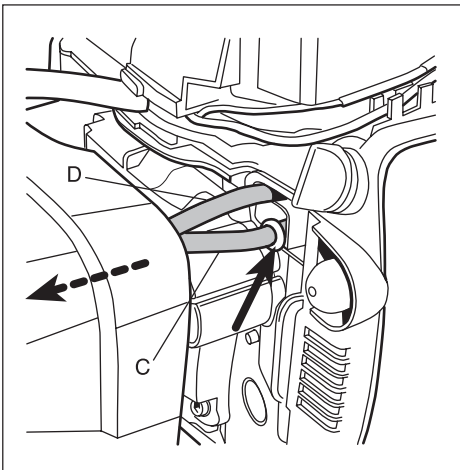

Move the fuel tank so far forward that the fuel hoses (C) and (D) can be removed.

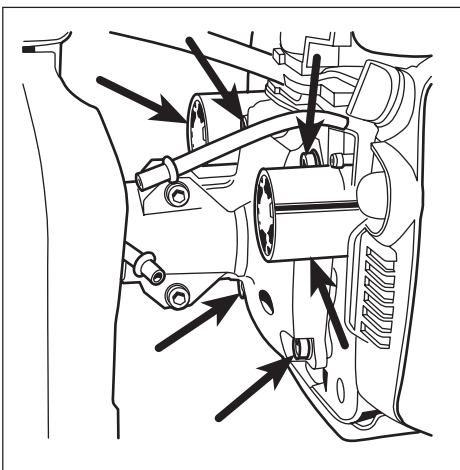

Remove the 4 bolts holding the clutch cover.

Dismantle the vibration dampers for better access.

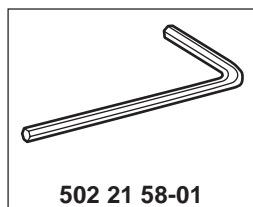

Dismantling

The clutch is located between the fuel tank and the engine.

In order to be accessible, the tank and handle holder must be moved forward on the shaft.

1. Dismantle the cable protector.
2. Loosen bolts (A) and (B).

3. Move the fuel tank so far forward that the fuel hose (C) becomes accessible.

Move the O-ring back and remove the hose from the nipple.

Also remove the fuel hose (D) from the nipple on the tank.

Move the fuel tank further forward and remove the 4 bolts holding the clutch cover to the engine.

Remove the vibration dampers from their plugs in order to facilitate dismantling.

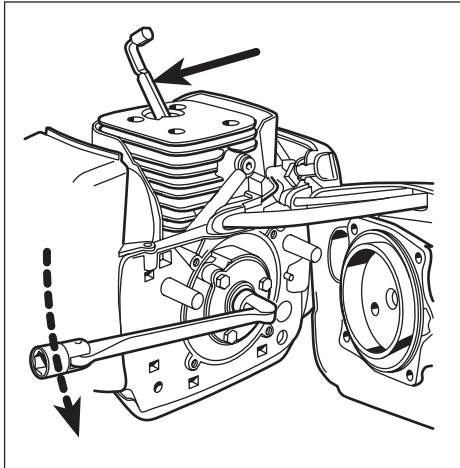

Dismantle the clutch from the crankshaft.

Replace the spark plug with piston stop no. 502 54 15-01.

Move the engine body to the side so that the clutch becomes accessible.

Unscrew the clutch from the crankshaft.

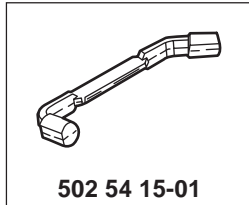

502 54 15-01

Fix the clutch in a vice and remove the 3 bolts.

Lift off the front cover plate and the clutch shoes.

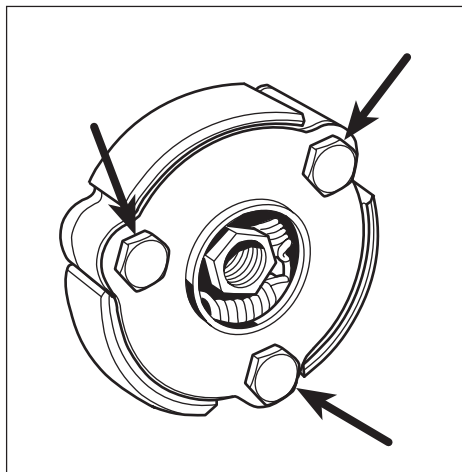

Remove the 3 bolts and separate the clutch.

NOTE!
Do not lose the sleeve bearings found in the clutch shoes.

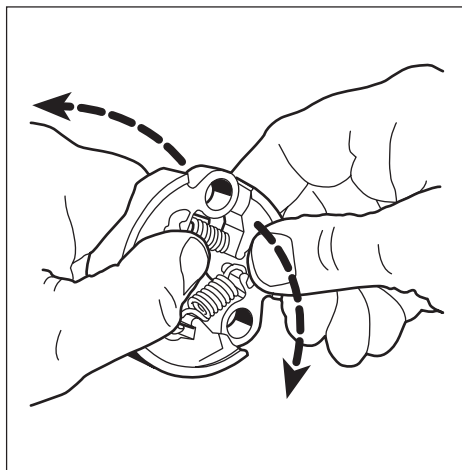

Twist apart the clutch.

Twist apart the clutch.

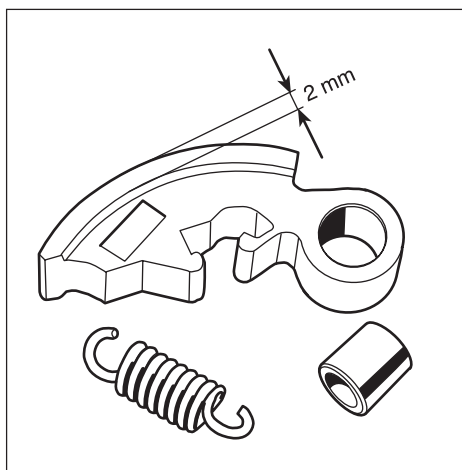

Clean and inspect the different parts with regard to wear or other damage.

Clean and inspect the different parts with regard to wear or other damage.

Wear on the clutch shoes must not be greater than shown in the illustration.

Check the play in the sleeve bearings in the clutch shoes and the wear on the springs by the fastening hooks.

4 Centrifugal clutch

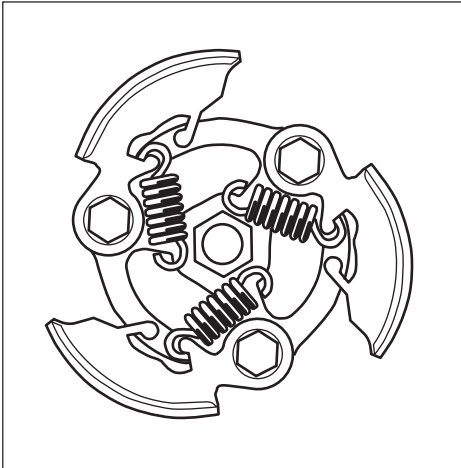

Assembly

Temporarily place the clutch shoes on the driving disc and loosely tighten the bolts.

Pry out the shoes and hook one spring to each shoe from underneath.

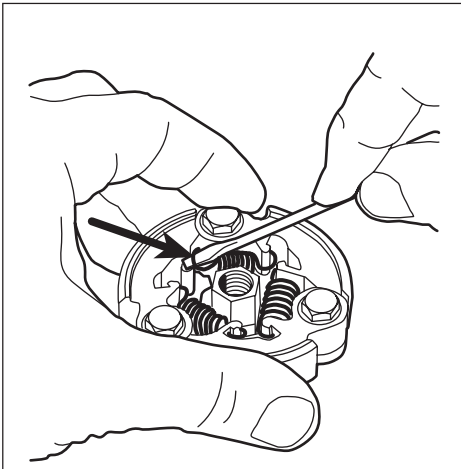

Get in the clutch shoes as far as possible and hook the springs to the adjacent clutch shoe.

Remove the bolts and mount the cover plate.

Fit the clutch to the crankshaft and the remaining parts in the reverse order as set out for dismantling.

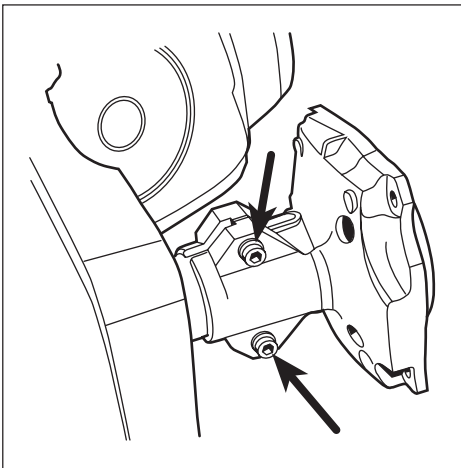

Clutch drum

Dismantle the clutch housing and the clutch drum and drive axle from the shaft.

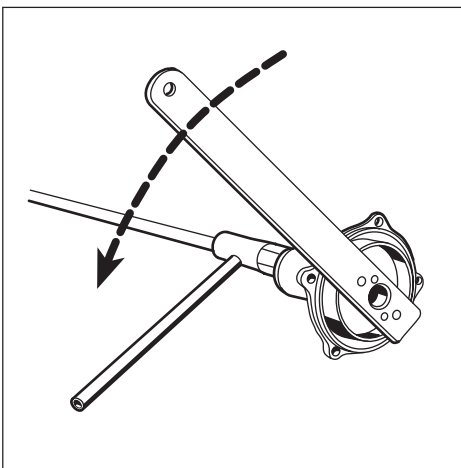

Unscrew the clutch drum from the drive axle.

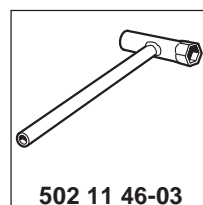
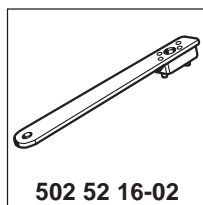

Assembly

Temporarily place the clutch shoes on the driving disc and loosely tighten the bolts.

NOTE!

The bevelled edge of the shoes should be facing outwards towards the cover plate.

Pry out the shoes and hook one spring to each shoe from underneath.

Fold in the clutch shoes as far as possible and hook the springs to the adjacent clutch shoe.

Use a small screwdriver or flat-nosed pliers.

NOTE!

Make sure that the spring eye is pressed into the correct position.

Remove the bolts and put the cover plate in place.

Tighten the bolts, fit the clutch to the crankshaft and the remaining parts in the reverse order as set out for dismantling.

Clutch drum

Separate the engine body and shaft as described previously.

Loosen the bolts holding the clutch housing against the shaft.

Remove the clutch housing and drive axle from the shaft.

Unscrew the clutch drum from the drive axle.

NOTE!

Avoid fixing the drive axle in a vice. Marks can form on the axle even if protective jaws are used. This in turn leads to damage on the plastic insert in the shaft.

Use tools 502 52 16-02 and 502 11 46-03. Check the clutch drum for wear. The internal diameter must not exceed 70.0 mm.

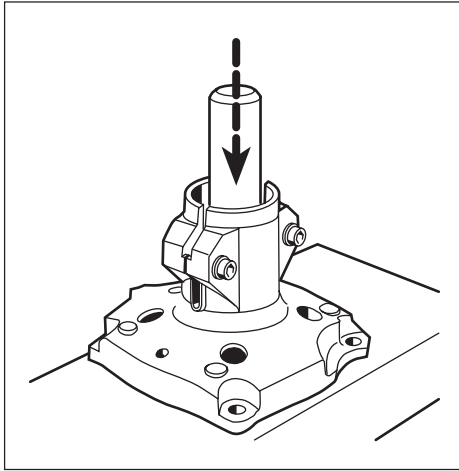

Change the bearings in the clutch housing if necessary.

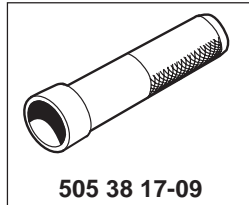

505 38 17-09

Change the bearings in the clutch housing if necessary.

Remove the circlip and push out the bearings with a suitable punch and hammer.

Dismantling is easier if the clutch housing is heated to about 110°C.

Assemble in the reverse order as set out for dismantling.

For Husqvarna Parts Call 606-678-9623 or 606-561-4983

Angle gear

5.

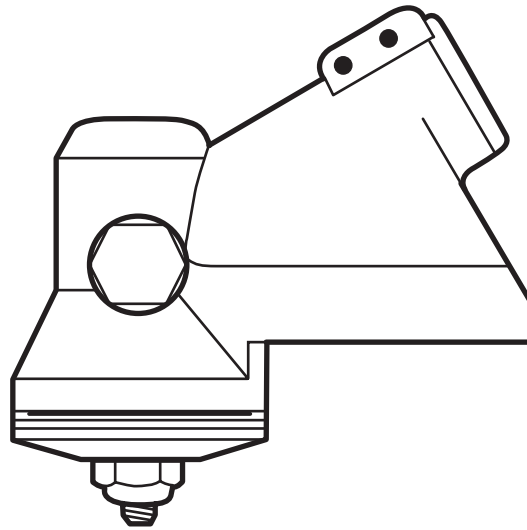

Contents

Dismantling _____	36
Assembly _____	37
Shaft _____	38

Angle gear

The angle gear has two purposes:

The first is to gear down the engine's high speed to better suit the lower speed a saw blade or trimmer requires to work efficiently.

Second, the angle gear contributes to the saw operator's working stance so that it is comfortable and at the same time efficient. The power from the engine, via the drive axle, shall in other words be angled so that the cutting equipment works parallel to the ground.

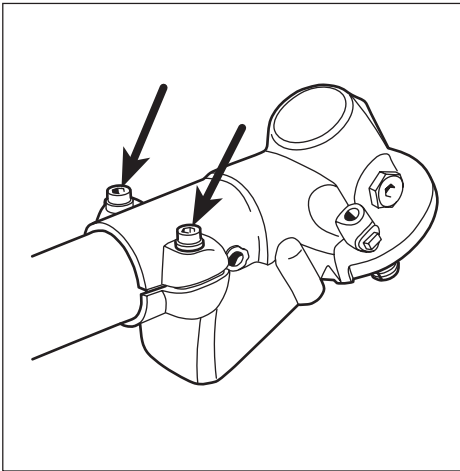

Dismantling

Remove the cutting equipment and guard.
Then loosen the bolts holding the angle gear against the shaft.
Remove the angle gear from the shaft.

Dismantling

First remove the cutting equipment (saw blade, trimmer etc.) and guard.
Then loosen the bolts holding the angle gear against the shaft.
Remove the angle gear from the shaft.
Use a screwdriver if necessary to separate the mechanical joint.

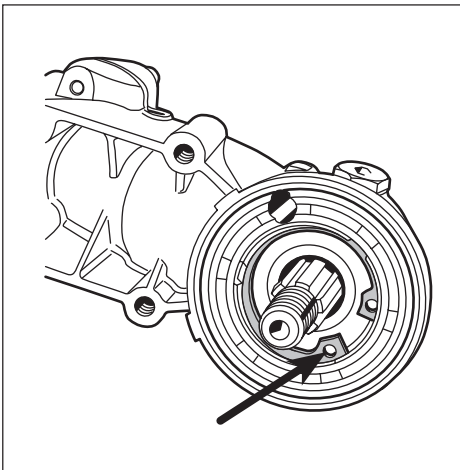

Remove the circlip and washer on the output axle.

Remove the circlip on the output axle using circlip pliers.
Lift off the washer from the sealing ring.

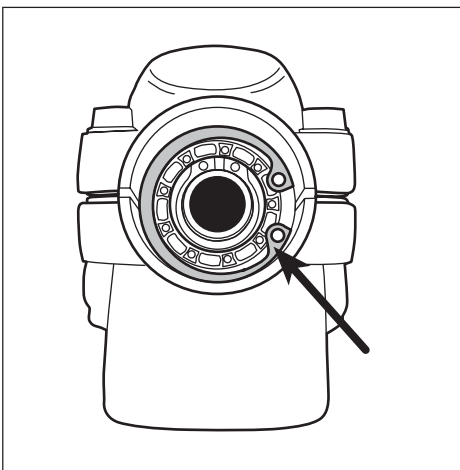

Remove the large circlip from the input axle.

Remove the large circlip from the input axle.

NOTE!

Let the small circlip around the axle remain.

Angle gear

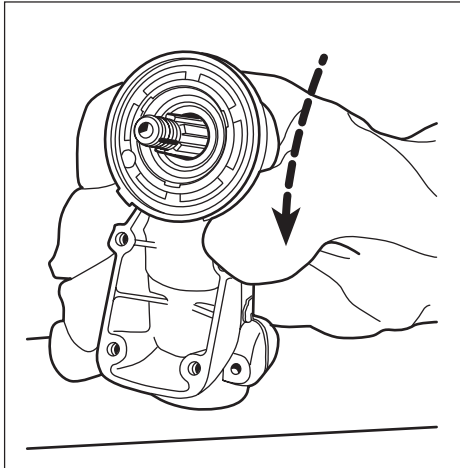

Remove the lubricant top-up plug.
Warm the gearbox and knock it against a wooden block so that the input axle falls out.

Remove the lubricant top-up plug and warm the entire gearbox using a hot air gun to about 150°C.

Knock the gearbox against a wooden block so that the input axle and bearing fall out.

NOTE!

The input axle with pinion must be dismantled first.

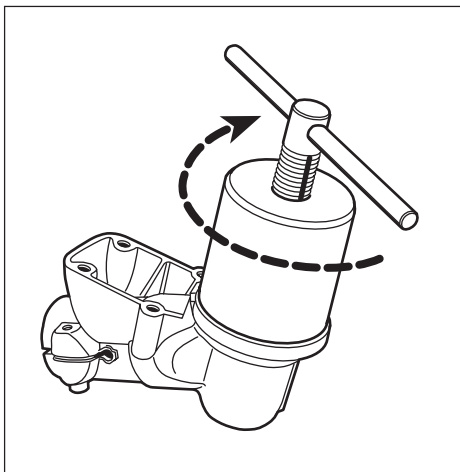

Remove the output axle.

Then remove the output axle and bearings, while the gearbox is still warm.

Use puller no. 502 50 65-01.

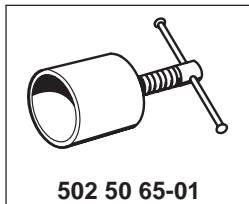

502 50 65-01

Assembly

Replace damaged parts.

Assemble the angle gear in the reverse order as set out for dismantling.

Fit the bearings on their respective axles. It is easier if the bearings are heated to approx. 100°C.

NOTE!

Do not forget the circlip holding the bearing on the input axle. Make sure the bearings bottom in their seats.

Heat the gearbox to approx. 150°C and first lift the output axle in position and then the input axle. Make sure the bearings bottom in their seats.

Mount the circlips and make sure they lie correctly in their grooves.

Rotate the axles and check that they rotate easily without a tendency for the cogwheels to seize.

Fill the gearbox with special grease no. 503 97 64-01. Wipe any excess grease from the joint between the shaft and the angle gear before the gear is fitted to prevent it from turning around the shaft.

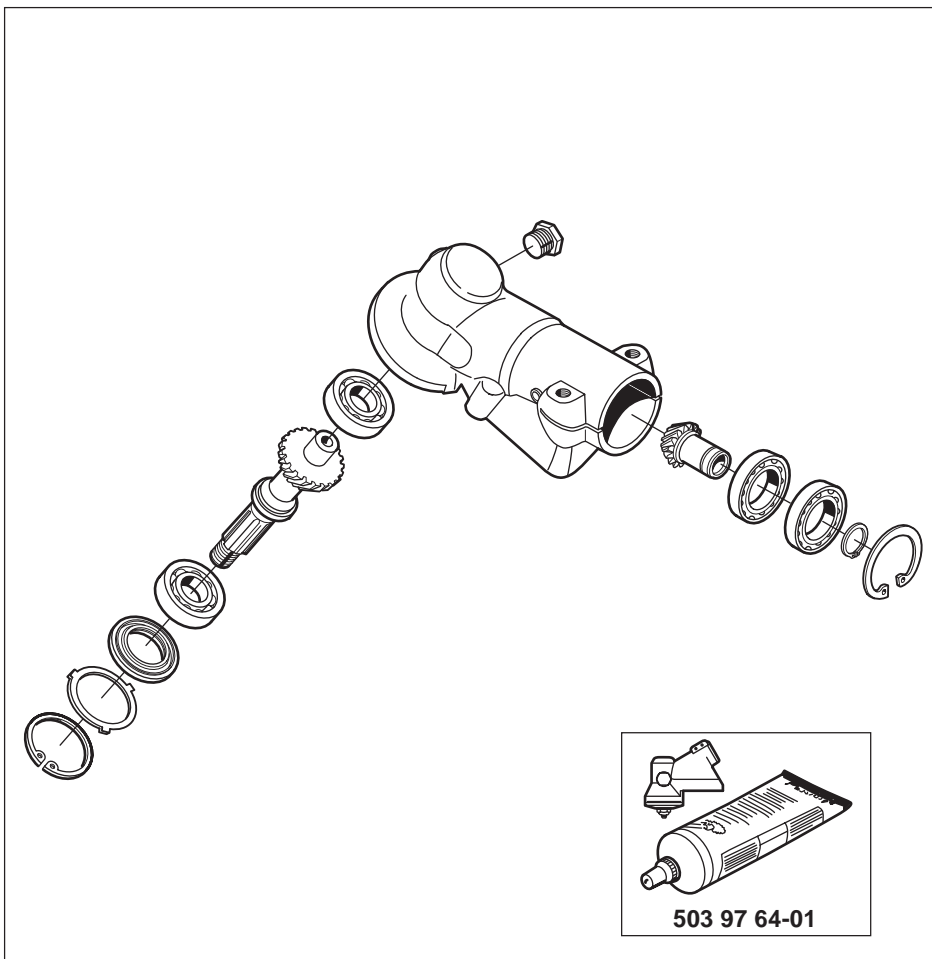

503 97 64-01

Angle gear

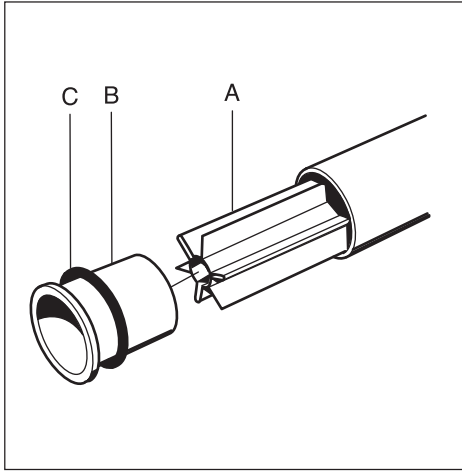

Shaft

The shaft contains a drive axle guide that is easily replaced. It can be dismantled once the plastic sleeve (B) has been removed.

Centre the axle control in the shaft when a new one is fitted.

Fit a new O-ring to ensure a good seal.

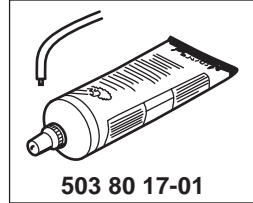

503 80 17-01

Shaft

The shaft contains a long plastic guide to prevent vibrations in the drive axle.

The guide (A) is easily removed for replacement.

Bend away the plastic sleeve (B) and the O-ring (C) using a knife and pull the drive axle guide out from the shaft.

When replacing the axle guide, the replacement must be inserted into the shaft so that the distance is the same to the two ends of the shaft.

When fitting, a new O-ring must be used. To avoid damage from the sharp edges of the slits in the gearbox, the following assembly procedure is recommended:

1. Place the plastic sleeve (B) in position in the gearbox.
2. Slide the O-ring (C) onto the plastic sleeve.
3. Slide the shaft and guide (A) into position.

Lubricate the drive axle with grease no. 503 80 17-01 when assembling.

Cylinder and piston

6.

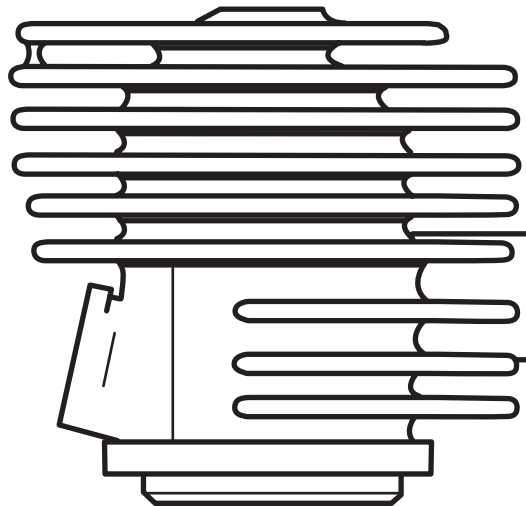

Contents

Dismantling	42
Decompression valve	43
Inlet manifold	44
Cleaning, inspection	44
Assembly	44
Analysis and actions	45
Service tips	49
Wear tolerances	50

6 Cylinder and piston

The cylinder and the piston are two of the components exposed to most strain in the engine. They must withstand, for example, high speeds, large temperature swings and high pressure. Moreover, they must be resistant to wear. Despite these tough working conditions, major piston and cylinder failure is relatively uncommon. The reasons for this include new coatings in the cylinder bore, new types of oil and grease and refined manufacturing techniques.

When servicing these components, cleanliness is of the utmost importance. It is therefore recommended that the cylinder and the area around it be thoroughly cleaned before being dismantled from the crankcase.

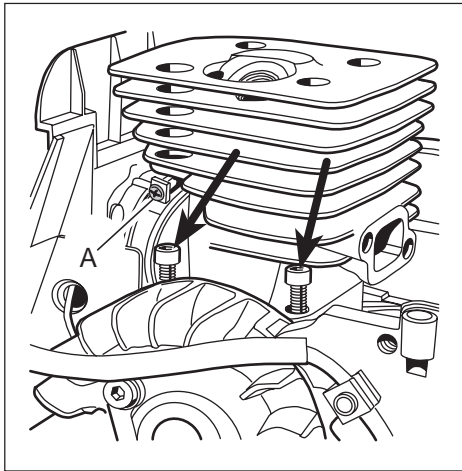

Dismantling

Dismantle the following components to make the cylinder accessible:
Starter, cylinder cover, muffler guard, muffler and spark plug.

NOTE!

The throttle need not be removed to dismantle the cylinder and piston.

Loosen the clamp (A) and unscrew the bolt a good distance (to facilitate the coming assembly) so that the clamp can be turned around the inlet manifold without affecting the cylinder.

Then loosen the 4 bolts holding the cylinder.

Carefully lift out the cylinder by twisting it backwards and forwards until it loosens from the inlet manifold. Make sure that no dirt enters the crankcase.

Use a rag to cover the crankcase opening under the piston.

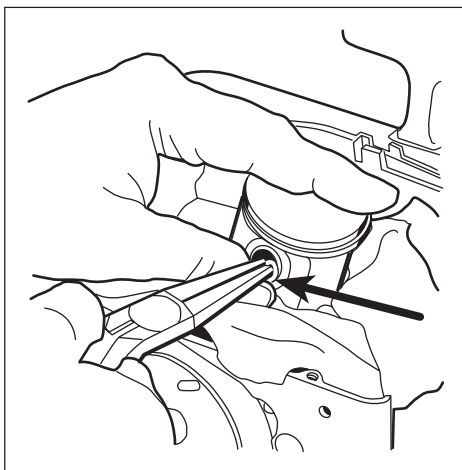
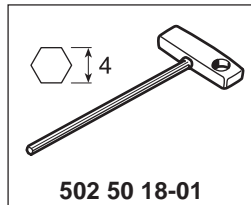

Remove the circlips from the gudgeon pin.

Using long-nose pliers remove the gudgeon pin circlips.

Keep your thumb over the circlip to prevent it from flying out.

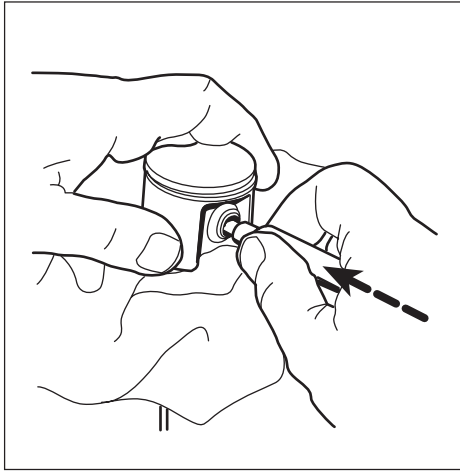

Dismantle the piston.

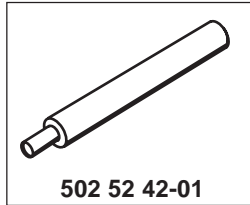

Push the gudgeon pin from the piston using punch 502 52 42-01.
If the pin is too tight, carefully warm the piston.

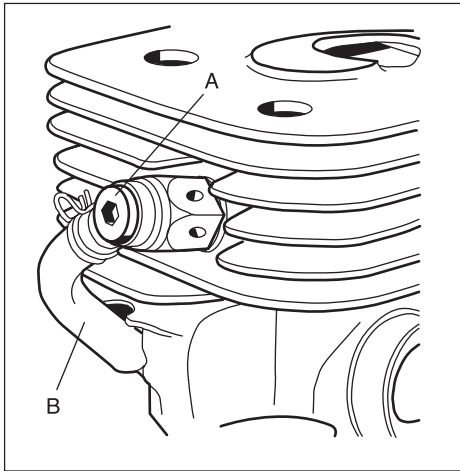

Decompression valve
Dismantle the decompression valve.

Decompression valve
Remove the bolt (A) and the hose (B) that connect the decompression valve to the nipple on the cylinder.
Unscrew the valve from the cylinder.

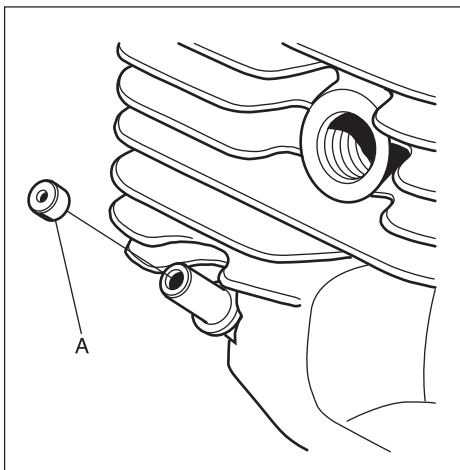

Check that the non-return valve (A) is tight under a vacuum of -50 kPa.
Otherwise replace the valve.

Inside the rubber sleeve on the nipple in the cylinder is a non-return valve (A).
Check with pressure gauge 531 03 06-23.
Pump up a vacuum of -50 kPa. The valve must be fully tight. Otherwise replace the valve.

NOTE!
Turn the valve the right way when fitting.



NOTE!
When the valve is fitted the small hole must face outwards.

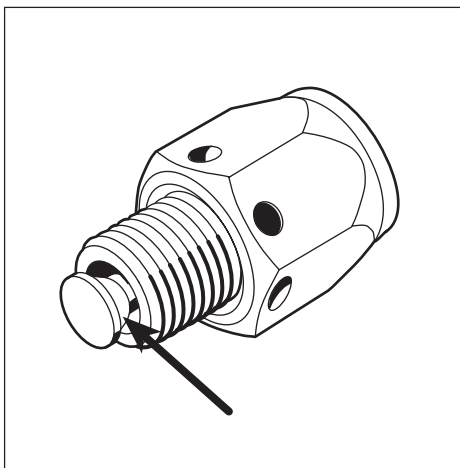

Clean the decompression valve and check that the valve head is not damaged (burnt) and that the valve operates easily.
If necessary, grind the valve with fine-grained valve grinding compound.

Clean the decompression valve with white spirit or thinner and blow dry with compressed air.
Check that the valve moves easily in the guide and that the valve head is not damaged (burnt).
If necessary, grind the valve into the seat using fine-grained valve grinding compound.

Tip!
Use washer no. 502 54 11-01 as a friction lining against the valve head when grinding.

Fit the decompression valve in the cylinder.

6 Cylinder and piston

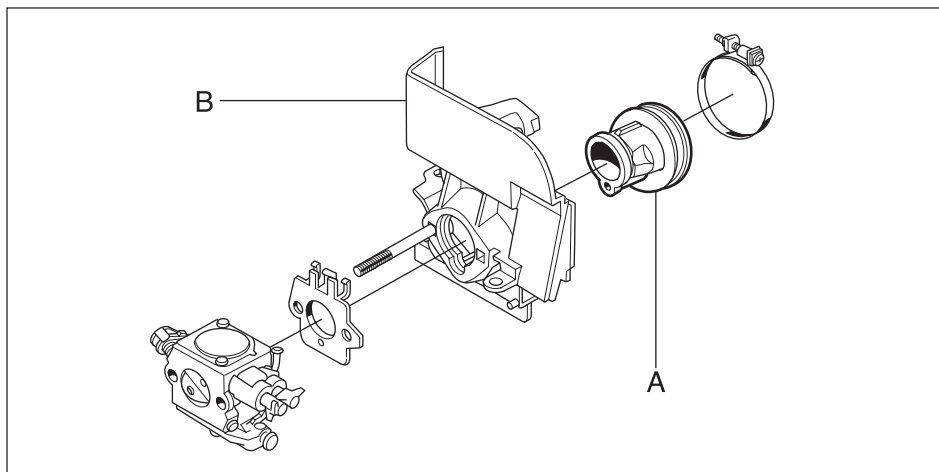

Inlet manifold

Remove the air filter and carburettor.
Remove the inlet manifold (A) from the partition (B). Check that it does not exhibit cracks or other damage that can cause leaks between the carburettor and cylinder. If necessary, fit a new inlet manifold in the reverse order as set out for dismantling.

NOTE!
Exercise caution if the inlet manifold is fitted using a screwdriver so as not to make any holes in the rubber wall.

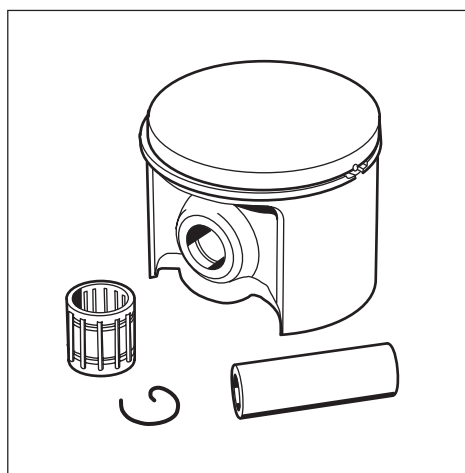

Cleaning, inspection

After dismantling, clean the individual components:

1. Scrape carbon deposits from the top of the piston.
2. Scrape carbon deposits from the cylinder's combustion chamber.
3. Scrape carbon deposits from the cylinder's exhaust port.

NOTE!
Scrape carefully with not too sharp a tool so as not to damage the soft aluminium parts.

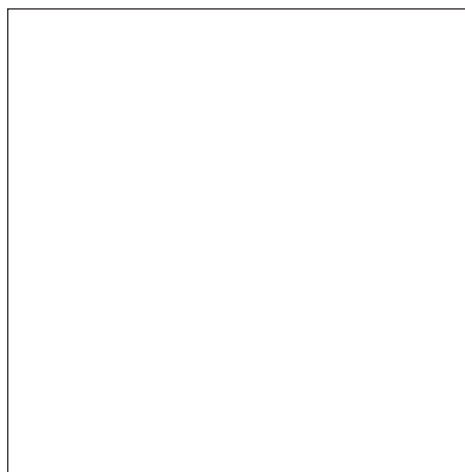

4. Wash all the components.
5. Inspect the different components for damage and wear.
Check the piston and cylinder for seizure damage and wear.
Also see the "Analysis and actions" section.
Check the piston ring for wear and damage.
Also see the "Analysis and actions" section.
Check the gudgeon pin.
 - If it has blued, it must be replaced.
 - If the piston moves too easily both the piston and the gudgeon pin must be replaced.
 Check the needle bearing. If it is discoloured or damaged, it must be replaced.
Check the circlips. If they exhibit cracks or are discoloured (caused by overheating), they must be replaced.

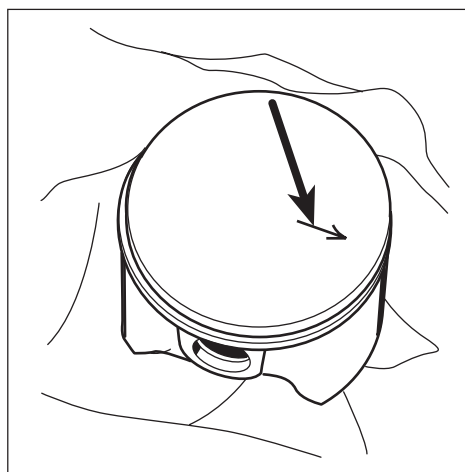

Assembly

Lubricate the gudgeon pin's needle bearing with a few drops of engine oil and fit the piston.

Assembly

Lubricate the gudgeon pin's needle bearing with a few drops of engine oil.
Direct the arrow on the top of the piston towards the exhaust port.
Press in the gudgeon pin and fit the circlips.

NOTE!
Place a rag in the crankcase opening to prevent the circlip from falling into the crankcase in case it should fly out.
Check that the circlips are correctly fitted into the grooves by turning the clips with long-nosed pliers.



Use a new gasket and fit the cylinder. Make sure that the inlet manifold is correctly connected to the sleeve coupling on the cylinder and that the impulse nipple sits right.



Place a new cylinder pedestal gasket on the cylinder.

Lubricate the piston and the inlet manifold on the cylinder with a few drops of engine oil and fit the cylinder using the smallest piston ring compressor in assembly kit 502 50 70-01.

Make sure that the inlet manifold is correctly connected to the sleeve coupling on the cylinder and that the impulse nipple sits right.

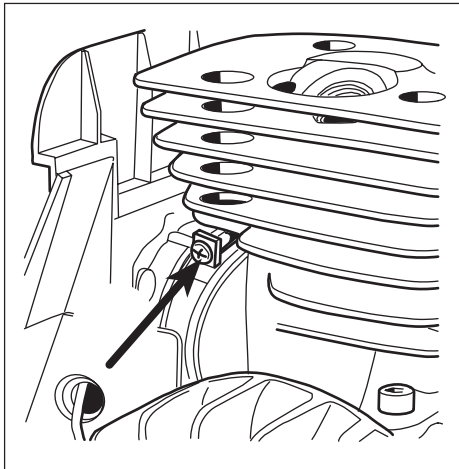

Screw the cylinder into place and tighten the clamp around the inlet manifold.

Assemble the other parts.

Screw the cylinder into place.

Tighten the clamp around the inlet manifold.

Assemble the carburettor and the other parts in the reverse order as set out for dismantling.

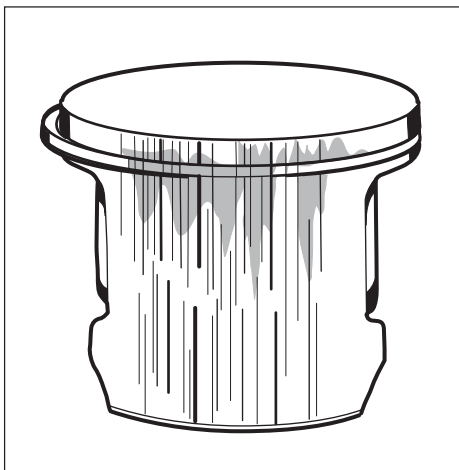

Small to medium size scores primarily in the middle of the exhaust port.

Analysis and actions

Experience tells us that piston or cylinder failure due to manufacturing errors are extremely rare.

The reason is usually due to other factors, which is evident from the following.

Note the reasons for the breakdown, repair the damage and take the actions required to prevent the same thing happening again.

Insufficient lubrication

The piston has small to medium size score marks usually in front of the exhaust port. In extreme cases heat development can be so great that material from the piston smears along the piston skirt and even in the cylinder bore.

Generally the piston ring is undamaged and moves freely in the ring groove

There can also be scores on the inlet side of the piston.

Cause:

- Incorrect carburettor setting. Recommended max. speed exceeded.
- Incorrect oil mixture in the fuel.
- Too low octane fuel.

Action:

- Check and change the carburettor setting.
- Change the fuel.
- Change to a higher octane petrol.

6 Cylinder and piston

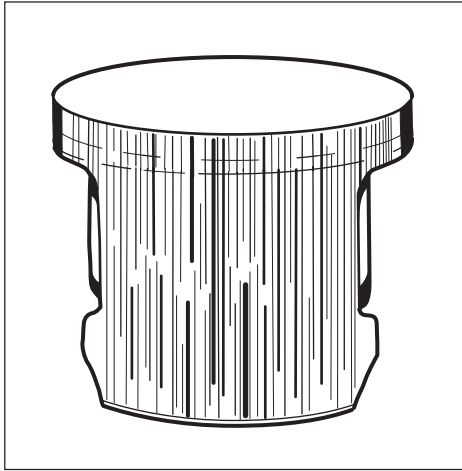

Medium to deep scores along the entire piston skirt on the exhaust side.

The piston ring starts to stick or is completely stuck in its groove and has therefore not been able to seal against the cylinder wall, which has resulted in further, intensive temperature increases in the piston

Seizure scores along the entire piston skirt on the inlet and exhaust sides.

Cause:

- Incorrect oil mixture in the fuel.
- Too low octane fuel.
- Air leaks.
 - Cracked fuel hose.
 - Leaking inlet gaskets.
 - Cracked distance piece or inlet manifold.
- Air leakage in engine body.
 - Leaking crankshaft seals.
 - Leaking cylinder and crankcase gaskets.
- Poor maintenance.
 - Dirty cooling fins on the cylinder.
 - Blocked air intake on the starter.
 - Blocked spark arrestor mesh in the muffler.

Action:

Change to a fuel with the correct oil mixture.
 Change to a higher octane petrol.
 Replace damaged parts.

Replace leaking gaskets and shaft seals.

Clean the cooling fins and air intake.

Clean or replace the spark arrestor mesh.

For the best results we recommend Husqvarna two-stroke oil or ready-mixed fuel that is specially developed for air-cooled two-stroke engines.

Mixing ratio: 1:50 (2%).

If Husqvarna two-stroke oil is not available another good quality two-stroke oil can be used.

Mixing ratio: 1:33 (3%) or 1:25 (4%).

Piston scoring caused by heavy carbon deposits

Too heavy carbon depositing can cause damage similar to that caused by insufficient lubrication. However, the piston skirt has a darker colour caused by the hot combustion gases that are blown past the piston.

This type of piston damage starts at the exhaust port where carbon deposits can become loose and get trapped between the piston and the cylinder wall.

Typical for this type of piston damage is brown or black discoloration of the piston skirt.

Cause:

- Wrong type of two-stroke oil or petrol.
- Incorrect oil mixture in the petrol.
- Incorrect carburettor setting.

Action:

Change the fuel.
 Change to a fuel with the correct oil mixture.
 Correct the carburettor setting

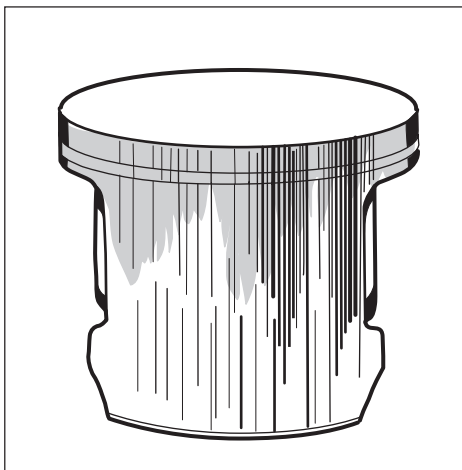

Medium to deep scores on the exhaust side. The piston ring is stuck in the groove. Black discoloration under the piston ring due to blow-by.



Exhaust side damaged by a broken piston ring. The piston ring parts damage the top section and cause score marks.

Piston damage caused by a too high engine speed. Typical damage associated with a too high engine speed includes broken piston rings, broken circlip on the gudgeon pin, faulty bearings or that the guide pin for the piston ring has become loose.

Piston ring breakage

A too "lean" carburettor setting results in a too high speed and a high piston temperature. If the piston temperature rises above the normal working temperature the piston ring can seize in its groove, consequently it will not sit deep enough in its groove. The edges of the piston ring can then hit the top edge of the exhaust port and be smashed and also cause piston damage.

A too high engine speed can also cause rapid wear to the piston ring and play in the piston ring groove primarily in front of the exhaust port. The ring is weakened by the wear and can be caught in the port causing serious piston damage.

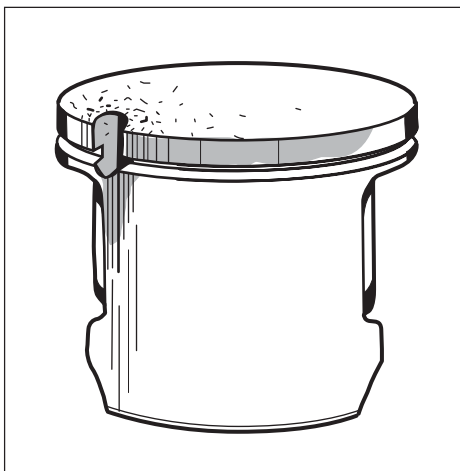

The guide pin for the piston ring has been pushed up through the top of piston.

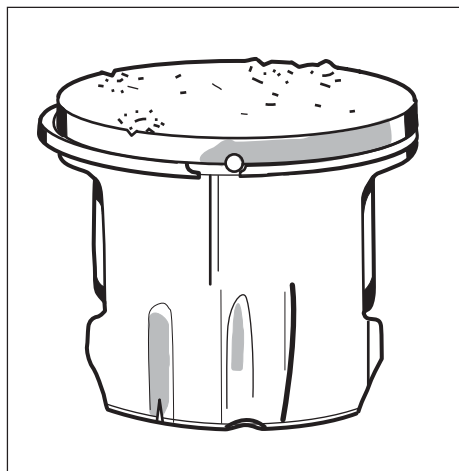

Deep, irregular grooves caused by a loose circlip. Shown here on the piston's inlet side.



Irregular grooves on the piston's inlet side caused by a broken roller retainer.

Piston ring guide pin vibrated loose

A too high engine speed can cause the ends of the piston ring to hammer against the guide pin when the piston ring moves in its groove. The intensive hammering can drive out the pin through the top of the piston causing serious damage also to the cylinder.

Damage caused by gudgeon pin circlips

A too high engine speed can cause the gudgeon pin circlips to vibrate. The circlips are drawn out of their grooves due to the vibrations, which in turn reduces the circlips' tensioning power. The rings can then become loose and damage the piston.

Bearing failure

Failure of the crankshaft bearing or on the connecting rod bearing is usually caused by a too high engine speed, resulting in the bearing being overloaded or overheating. This in turn can cause the bearing rollers or ball to glide instead of rotate, which can cause the roller or ball retainer to break.

The broken debris can be trapped between the piston and cylinder wall, damaging the piston skirt.

Debris can also pass up through the cylinder's transfer channels and cause damage to the top and sides of the piston as well as to the cylinder's combustion chamber.

6 Cylinder and piston

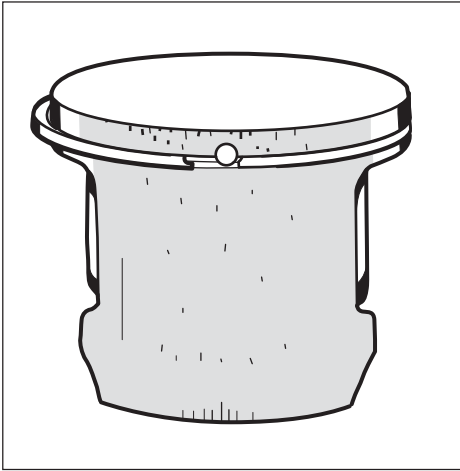

Small score marks and a matt, grey surface on the piston's inlet side caused by fine dust particles.

Foreign objects

Everything other than clean air and pure fuel that enters the engine's inlet port causes some type of abnormal wear or damage to the cylinder and piston.

This type of increased wear shows on the piston's inlet side starting at the lower edge of the piston skirt.

The damage is caused by badly filtered air that passes through the carburettor and into the engine.

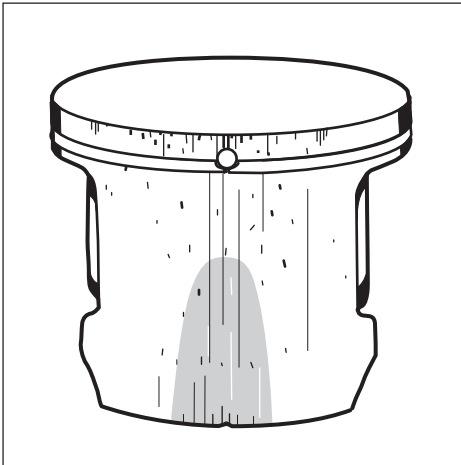

*Inlet side.
Particles of dust and dirt from carbon-like deposits on the top of the piston and in the piston ring groove. The piston ring sits firmly in the groove. Piston material has been worn away.
The lower part of the piston skirt is thinner on the inlet side than on the exhaust side.*

Cause:

- Faulty air filter. Small dust particles pass through the filter.
- The filter is worn out due to too much cleaning, whereby small holes have appeared in the material.
- Unsuitable filter maintenance, such as wrong method or wrong cleaning agent. Flock material becomes loose and holes appear.
- Air filter incorrectly fitted.
- Air filter damaged or missing.

Action:

- Fit a finer grade filter.
- Check the filter carefully for holes and damage after cleaning. Replace the filter if necessary.
- Clean more carefully and use the right cleaning agent (such as tepid soapy water).
- Change the filter.
- Fit the filter correctly.
- Fit a new air filter.

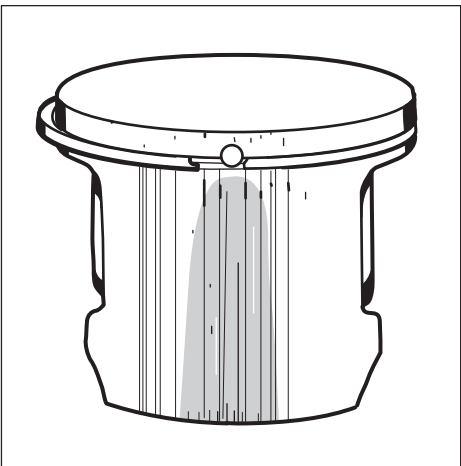

The piston scored and worn from the piston ring down on the inlet side.

Larger, softer particles that penetrate into the engine cause damage to the piston skirt under the piston ring as the illustration shows.

Cause:

- Air filter incorrectly fitted.
- Air filter damaged or missing.

Action:

- Fit the air filter correctly.
- Fit a new air filter.

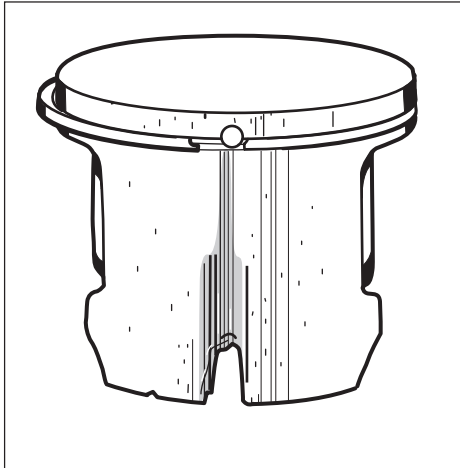

Extensive damage to the lower part of the piston's inlet side.

Larger, harder particles that enter the engine cause serious damage to the underside of the piston skirt.

Cause:

- Air filter damaged or missing.
- Parts from the carburettor or intake system have come loose and entered the engine.

Action:

- Fit a new air filter.
- Regular service and inspection.

Service tips

Defect:

Broken cooling fins, damaged threads or sheared bolts by the exhaust port.

Seizure marks in the cylinder bore (especially by the exhaust port).

Surface coating in the cylinder bore worn out (primarily at the top of the cylinder).

The piston shows signs of seizure score marks.

Piston ring burnt in its groove.

Bolts much too tight in the aluminium material.

Action:

In severe cases – replace the cylinder.
Repair the threads using Heli-Coil.

Polish the damaged area using a fine grade emery cloth so that the coating of aluminium disappears.

With deep seizure score marks the piston and cylinder should be replaced.

Replace the cylinder and piston.

Carefully polish the damaged area using a fine file of fine grade emery cloth. Before the piston is refitted the cylinder should be polished as above. With deep score marks the piston and cylinder should be replaced.

Carefully loosen the piston rings and clean the groove well before refitting. Carbon deposits in the groove impair the important heat transfer between the piston and cylinder.

NOTE!

Be careful with the lower edge of the piston ring groove. If this is damaged, or if carbon deposits remain, the compression pressure can leak through.

Check the wear on the piston ring by placing it in the lower part of the cylinder.

Position a suitable punch on the bolt head and give a few sharp knocks with a hammer. If the bolt still does not loosen, repeat the procedure.

6 Cylinder and piston

Wear tolerances

Cylinder bore

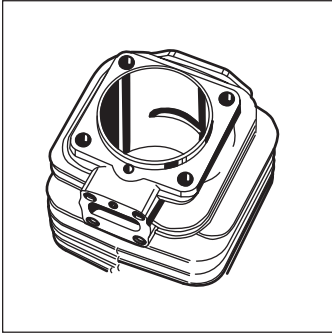

When the surface coating is worn and aluminium appears.

Piston ring gap

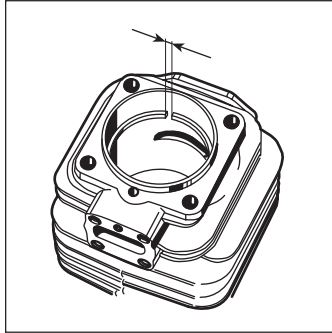

Max. 1.0 mm with the piston ring inserted in the lower part of the cylinder.

Piston ring groove

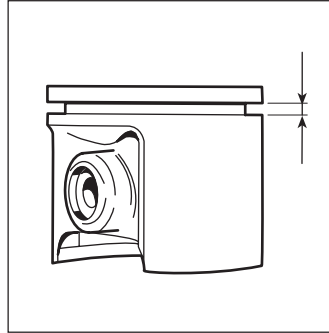

Max. 1.6 mm. Clean the groove before checking the measurement.

Piston ring play

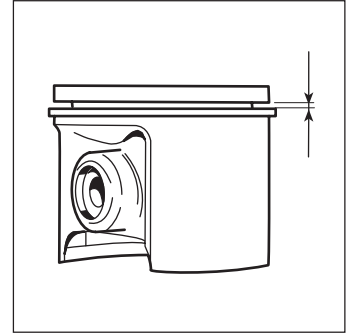

Max. 0.15 mm. Clean the groove before checking the measurement.

Crankshaft and crankcase

7.

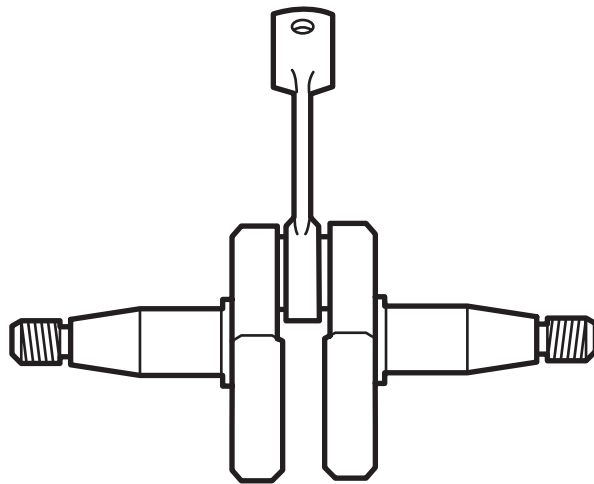

Contents

Dismantling	52
Inspecting the crankshaft	54
Assembly	55
Leakage testing the crankcase	56

The task of the crankshaft is to transform the reciprocating motion of the piston to rotation. This requires a stable design withstanding immense pressure and rotational and bending strain, as well as high rotational speed. In addition the connecting rod is exposed to large acceleration and retardation forces as it moves between the top and bottom dead centres. This puts special demands on the bearings that must withstand quick changes in load. Moreover, the bearing's roller retainer must also cope with high temperatures and friction. It is therefore extremely important when servicing to check the roller retainer for cracks, wear and discolouration caused by overheating.

The crankshaft is journalled in the crankcase on heavy-duty ball bearings. In addition to the journalling point for the crankshaft, the crankcase acts as a scavenging pump for the fuel/air mixture when this is "sucked" from the carburettor and is forced into the cylinder's combustion chamber. The crankcase must be perfectly sealed so as not to affect this pump function. There cannot be any leakage from the crankshaft, between the crankcase halves or between the crankcase and the cylinder.

Always replace the sealing rings and gaskets when servicing the crankcase.

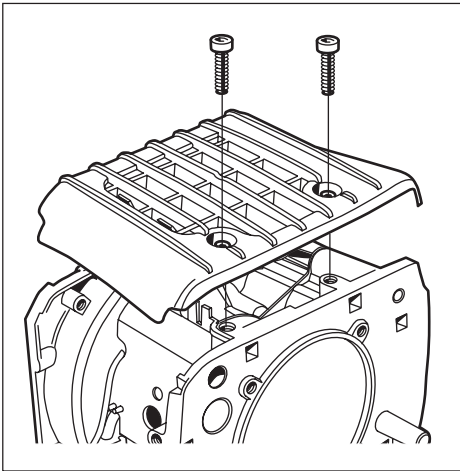

Dismantling

Dismantle all components so that only the crankcase and crankshaft remain.

Dismantle the guard under the crankcase.

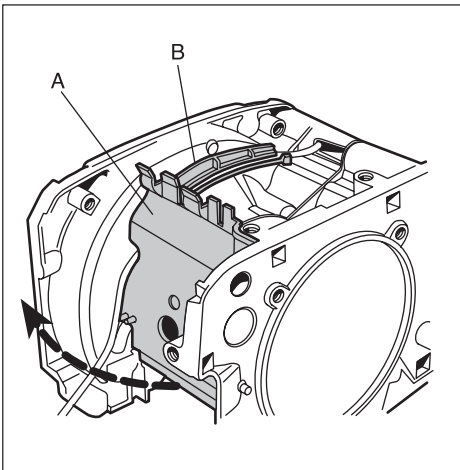

Bend away the heat guard (A) and cable guide (B).

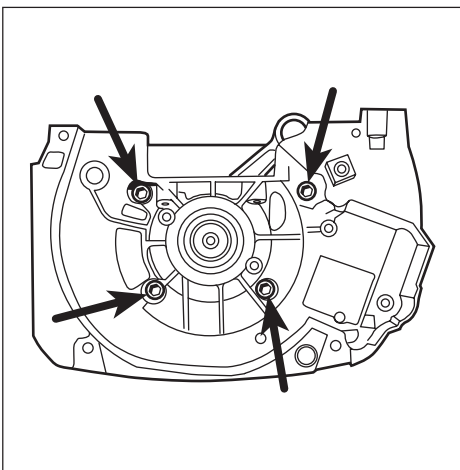

Remove the 4 bolts holding the crankcase halves together.

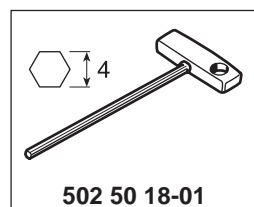

Dismantling

Dismantle all components so that only the crankcase and crankshaft remain.

See the respective sections for detailed information if necessary.

Remove the 4 bolts and lift off the guard from under the crankcase.

Bend away the heat guard (A) with your fingers and carefully push the cable guide (B) aside with a screwdriver.

Remove the 4 bolts holding the crankcase halves together.

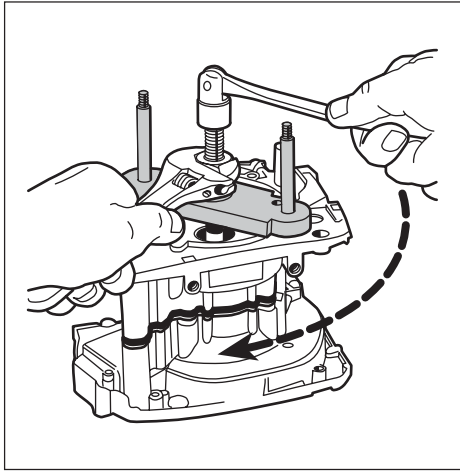

Separate the crankcase halves.

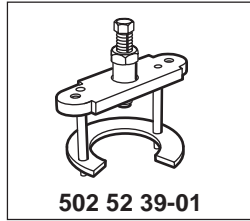

502 52 39-01

Fit tool 502 52 39-01 to the clutch side of the crankcase as illustrated. Separate the crankcase halves.

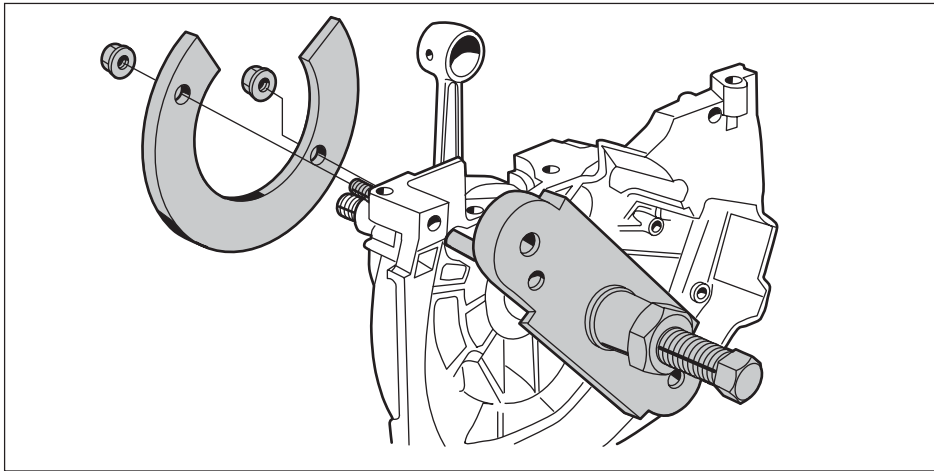

Fit tool 502 52 39-01 as illustrated.

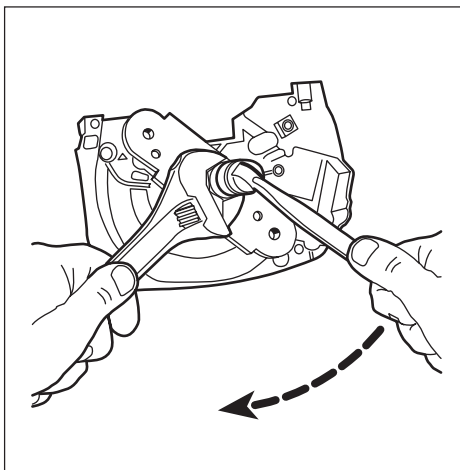

Push out the crankshaft from the crankcase half.

Push out the crankshaft from the crankcase half.

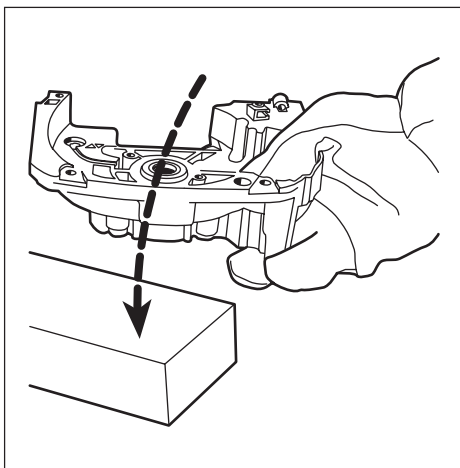

Remove the bearing and sealing rings from the crankcase halves.

Heat the crankcase halves to approx. 150°C using a hot air gun.

Knock the halves against a wooden block so that the bearings fall out of their seats.

Remove the gaskets with a suitable punch.

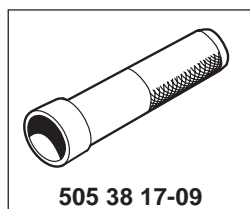

505 38 17-09

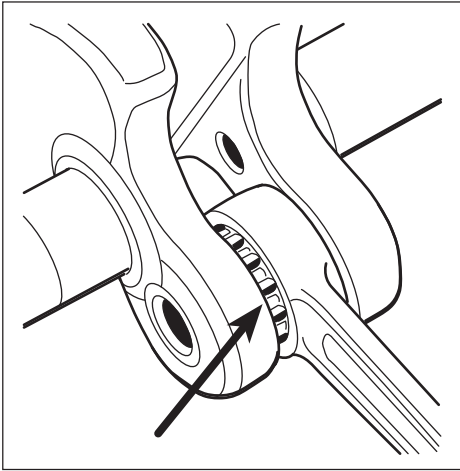

Inspecting the crankshaft

Inspect the large end of the connecting rod.

Inspecting the crankshaft

The crankshaft cannot be reconditioned but must be replaced if it is worn or damaged.

Inspect the large end of the connecting rod. If seizure marks, discolouration on the sides or damaged needle holders are found the crankshaft must be replaced.

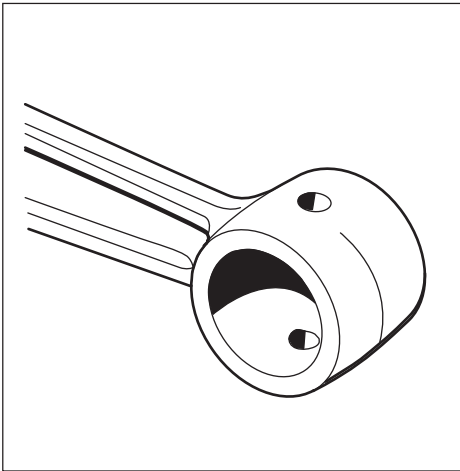

Inspect the small end of the connecting rod.

Inspect the small end of the connecting rod.

If seizure marks or discolouration are found in the bearing track the crankshaft must be replaced.

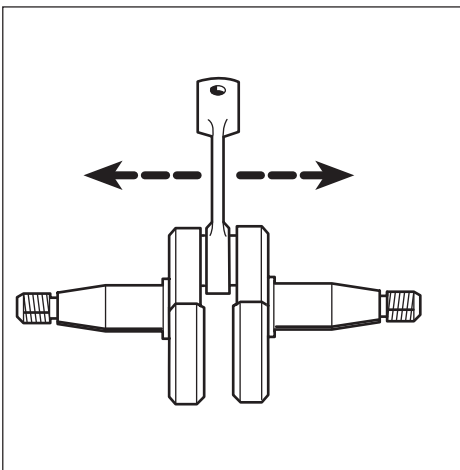

Check the crank bearing.

Check the crank bearing. The connecting rod shall not have any radial play (up and down).

It should, however, have axial play, in order to ensure good lubrication of the crank bearing among other things.

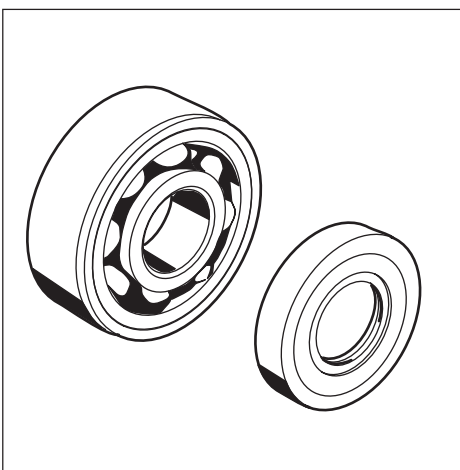

Inspect the crankshaft bearing and sealing rings.

Check for wear in the crankshaft bearing and sealing rings.

Clean the bearings and rotate the outer ring. If movement is "jerky" the bearing track is probably damaged. If so, replace the bearing.

Also check that the gap is not too great. Inspect the sealing rings. The seal edge shall be sharp or slightly ground.

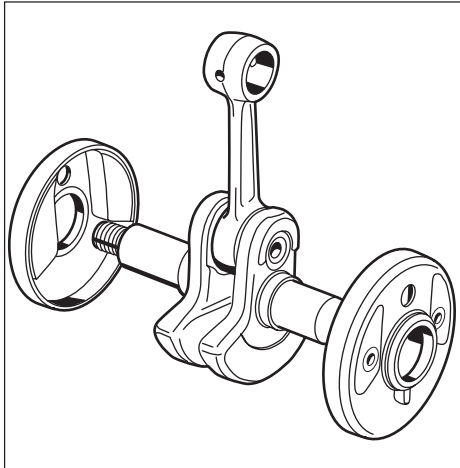

Check that there is no play in the fill-out plates around the crank disks (applies to models F_X/F_{XT}, R_X).

Check that there is no play in the fill-out plates around the crank disks (applies to models F_X/F_{XT}, R_X).

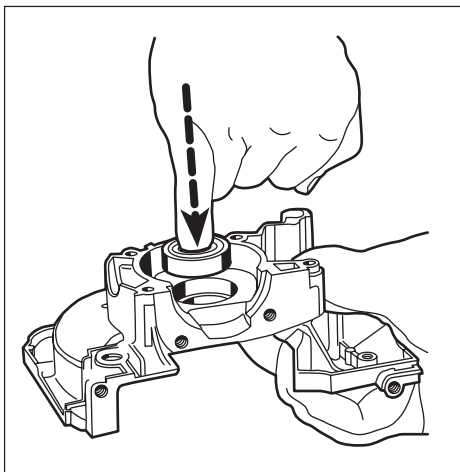

Assembly

Mount the bearings in the crankcase halves.

Assembly

Heat the crankcase halves to approx. 150°C using a hot air gun and position the bearings.

Make sure they go right down into the bearing seats.

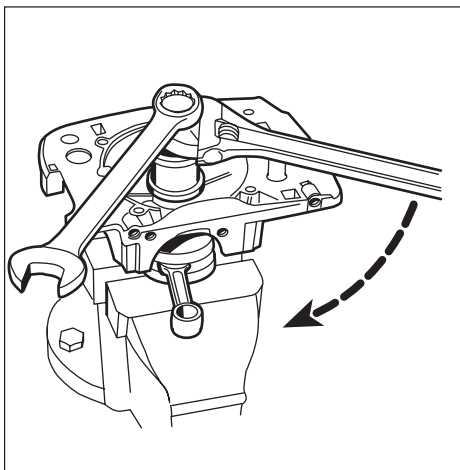

First fit the crankshaft in the clutch-side crankcase half.

Lubricate the big-end bearing with a few drops of engine oil and position the crankshaft in the clutch-side crankcase half.

Pull the crankshaft into place with tool no. 502 50 30-19.

Make sure that the connecting rod is not squeezed against the crankcase!

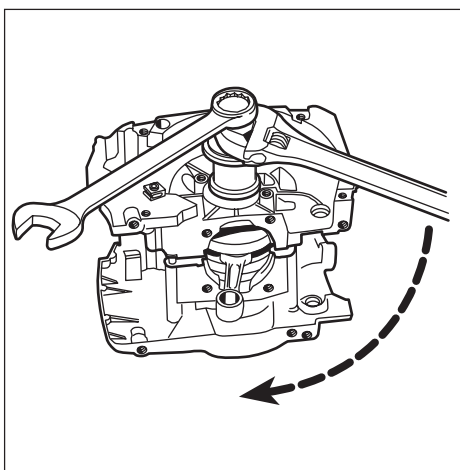
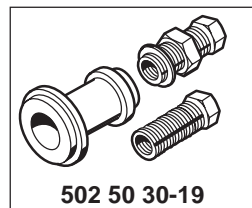

Fit a new gasket to the clutch-side crankcase half.

Pull the other crankcase half into position and tighten the 4 crankcase bolts.

Fit a new gasket to the clutch-side crankcase half.

Place the other crankcase half over the crankshaft and place the 4 crankcase bolts so that they guide the gasket.

Pull the crankcase half into place with tool no. 502 50 30-19.

Tighten the crankcase bolts.

Check that the crankshaft can rotate easily. If not, hit the axle spindles sharply a few times with a rubber hammer so that the tension in the crankshaft disappears.

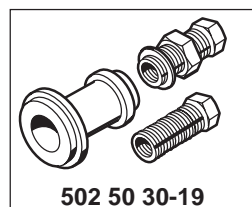

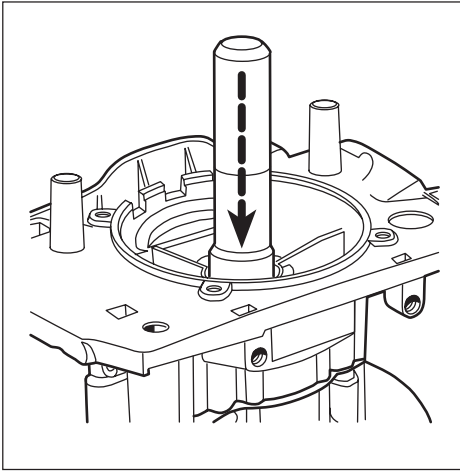

Fit the sealing rings.

Lubricate the axle spindles with engine oil and press the sealing rings until level with the crankcase using a suitable punch or tool 502 50 30-19.

The metal covers of the sealing rings should face outwards!

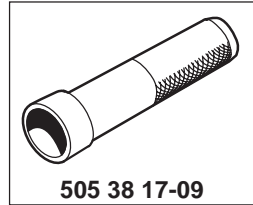

505 38 17-09

Assemble the remaining parts in the following order:

1. Cable guide and heat guard on the carburettor side of the crankcase.
2. Protective grating on the underside of the crankcase.
3. Piston and cylinder.
4. Partition on the carburettor side with attached inlet manifold.

NOTE!

If the inlet manifold has been removed, no sharp implements may be used to replace it as there is a risk that holes will be made in the inlet manifold. This would result in poor idling.

5. Generator. Make sure that the cable is pressed into the groove in the crankcase.
6. Flywheel.
7. Ignition module.
8. Muffler and heat shield.
9. Carburettor with fitted air filter holder and bushings for fuel hoses.
10. Clutch.
11. Shaft.

Leakage testing the crankcase

Fit the two sealing plates (A) and the pressure test nipple (B).

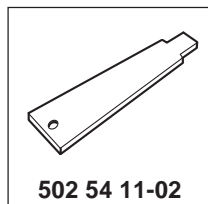

502 54 11-02

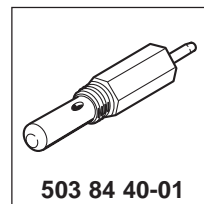

503 84 40-01

Leakage testing the crankcase

Remove the throttle cable and air filter holder from the carburettor. Fit a sealing plate (A) 502 54 11-02 between the carburettor and the distance piece and a plate between the cylinder and the heat guard plate by the muffler.

NOTE!

Press down the sealing plates as far as possible between the bolts to ensure a proper seal.

Fit the pressure test nipple (B) 503 84 40-01 in the spark plug hole.

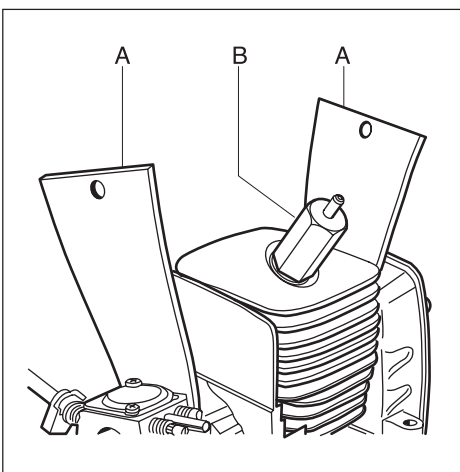

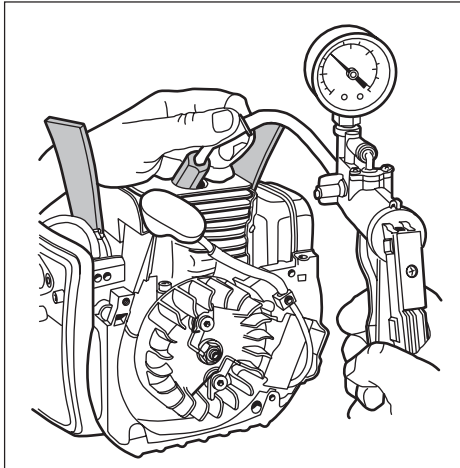

Fit plug 503 55 22-01 instead of the decompression valve.
Connect meter 531 03 06-23 and check for leakage.

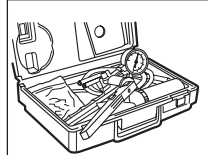

531 03 06-23

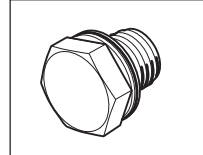

503 55 22-01

Fit plug 503 55 22-01 instead of the decompression valve.
Connect meter 531 03 06-23 to the nipple and pump up a pressure of 50 kPa (0.5 kp/cm²) in the crankcase.

Max. permitted leakage:
20 kPa (0.2 kp/cm²) per 30 seconds.

Connect meter 531 03 06-23 to the nipple and lower the pressure in the crankcase to 50 kPa (0.5 kp/cm²).

Max. permitted leakage:
20 kPa (0.2 kp/cm²) per 30 seconds.

Any leakage can be difficult to localise if the crankcase is depressurised.

When leakage has been established with a vacuum, you can apply a slight overpressure (0.1–0.3 kp/cm²) and at the same time apply a layer of thin oil to the joints and the sealing ring contact surfaces on the crankcase to make leak detection easier. Bubbles clearly mark the position of the leakage.

Husqvarna E-Tech

In 1996 Husqvarna presented a new, improved two-stroke engine as a part of the company's efforts to produce engines that emit smaller amounts of hazardous substances.

The new engine was given the designation E-Tech and was first used in a new brush cutter model.

More stringent environment regulations in the USA, which primarily involve a lowering of the hydrocarbons, nitrous oxides and carbon monoxide content, brought about the new engine design.

Environment degradation is reduced through decreasing the amount of unburned gases (flushing losses) in the exhaust fumes.

Comparisons between an E-Tech engine and an older engine design show that the CO content has been halved and the hydrocarbons and nitrous oxide contents have been reduced by close to 70%. In addition a powerful increase in output is gained.

What makes the E-Tech engine design unique is not a specific design solution but rather several solutions interacting to reduce flushing losses in the engine.

The carburettor's job is to mix the air and fuel in the right proportions to give a combustible mixture, irrespective of the speed and workload. The carburettor's adjustable needles have been fitted with movement limiters to prevent the engine from being run with a too "rich" fuel/air mixture. (Also see the "Fuel system" chapter).

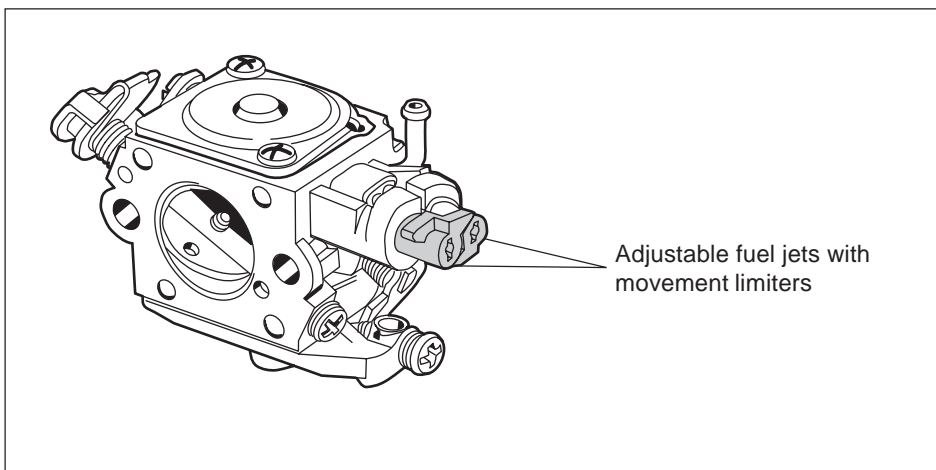
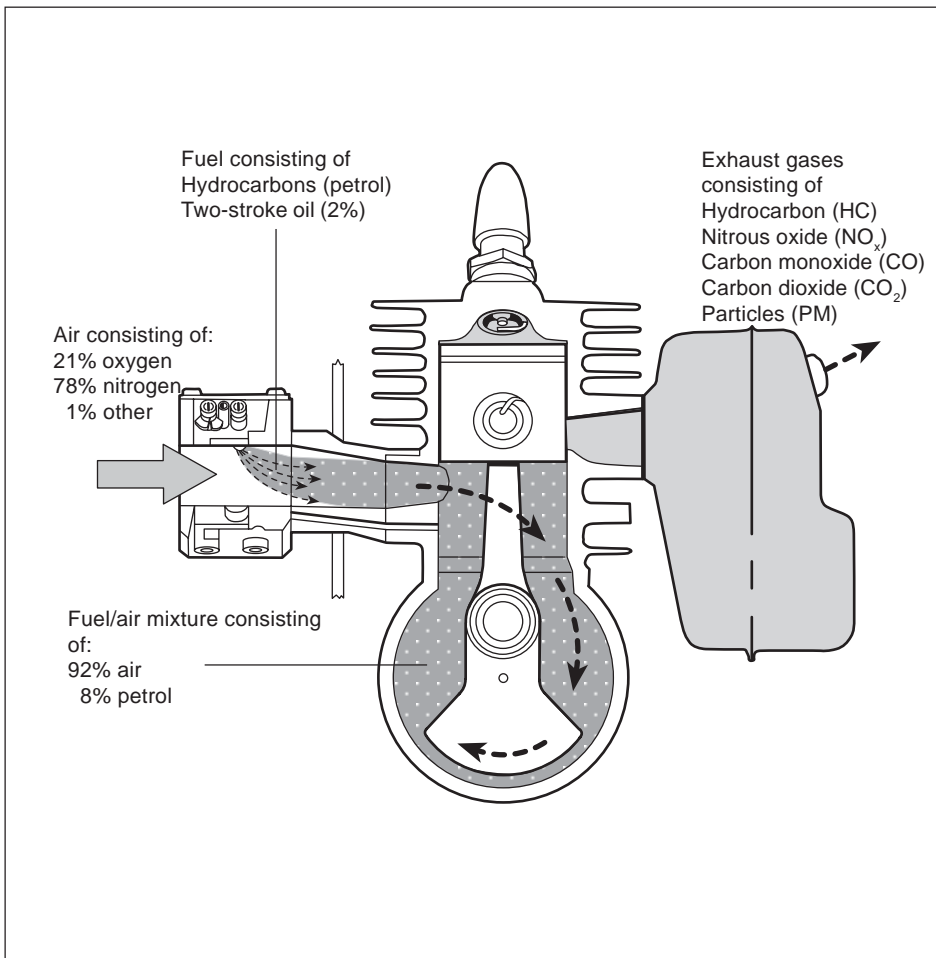

For Husqvarna Parts Call 606-678-9623 or 606-561-4983

Verktyg



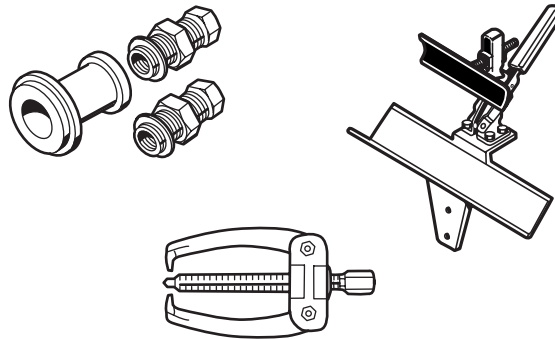

8.

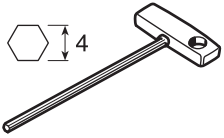
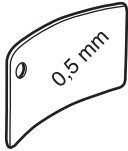

Contents

Starter _____	60
Electrical system _____	60
Fuel system _____	60
Centrifugal clutch _____	60
Angle gear _____	61
Cylinder and piston _____	61
Crankshaft and crankcase _____	61
Workshop equipment _____	61

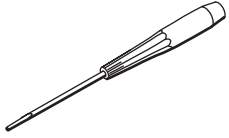
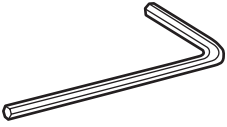
List of tools

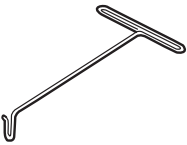
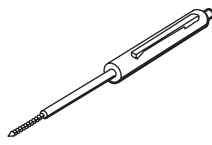
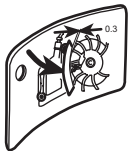
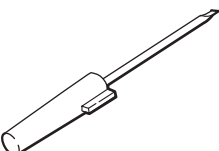
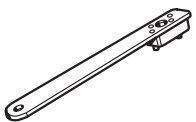
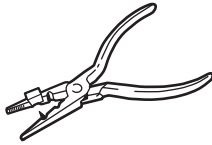
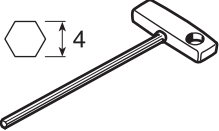
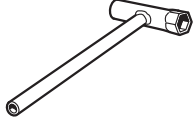
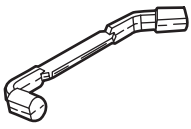
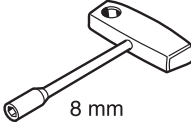
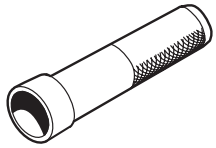
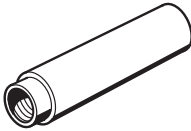
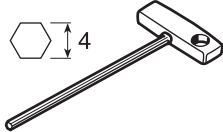
Starter	Electrical system	Fuel system	Fuel system	Centrifugal clutch
 <p>502 50 18-01</p>	 <p>502 51 91-01</p>	 <p>531 00 60-76</p>	 <p>531 00 48-63</p>	 <p>502 21 58-01</p>
	 <p>502 71 13-01</p>	 <p>502 50 83-01</p>	 <p>531 03 03-98</p>	 <p>502 54 15-01</p>
	 <p>502 51 34-02</p>	 <p>501 60 02-03</p>		 <p>502 52 16-02</p>
	 <p>502 50 06-01</p>	 <p>502 50 18-01</p>		 <p>502 11 46-03</p>
	 <p>502 54 15-01</p>	 <p>505 38 13-08</p>		 <p>505 38 17-09</p>
	 <p>502 51 94-01</p>			
	 <p>502 50 18-01</p>			

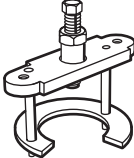
Angle gear	Cylinder and piston	Crankshaft and crankcase	Workshop equipment	
 <p>502 50 65-01</p>	 <p>502 52 42-01</p>	 <p>502 52 39-01</p>	 <p>502 51 03-01</p>	
 <p>503 97 64-01</p>	 <p>502 50 70-01</p>	 <p>505 38 17-09</p>	 <p>531 03 06-23</p>	
 <p>503 80 17-01</p>	 <p>502 50 18-01</p>	 <p>502 50 30-19</p>	 <p>502 71 14-01</p>	
		 <p>502 54 11-02</p>	 <p>505 69 85-70</p>	
		 <p>503 84 40-01</p>	 <p>101 64 23-48</p>	
		 <p>503 55 22-01</p>	 <p>101 64 23-48</p>	
		 <p>502 50 18-01</p>	 <p>503 26 70-01</p>	

For Husqvarna Parts Call 606-678-9623 or 606-561-4983



www.husqvarna.com

114 01 98-26

2003W24

www.mymowerparts.com