





SERVICE 		6
		X 91.116-26

MODELS 40/45, 51/55

STARTER

We have increased the inner diameter on the pulley centre post due to plastic moulding reasons. This requires a bigger screw. The change is already introduced on the models 51/55 and will be introduced on the models 40/45.

The old screw, 503 21 32-16 will be replaced by the new one, 503 21 06-16. This means that the old pulley hole for the starter must be modified in order to fit the new screw. See the illustration below.

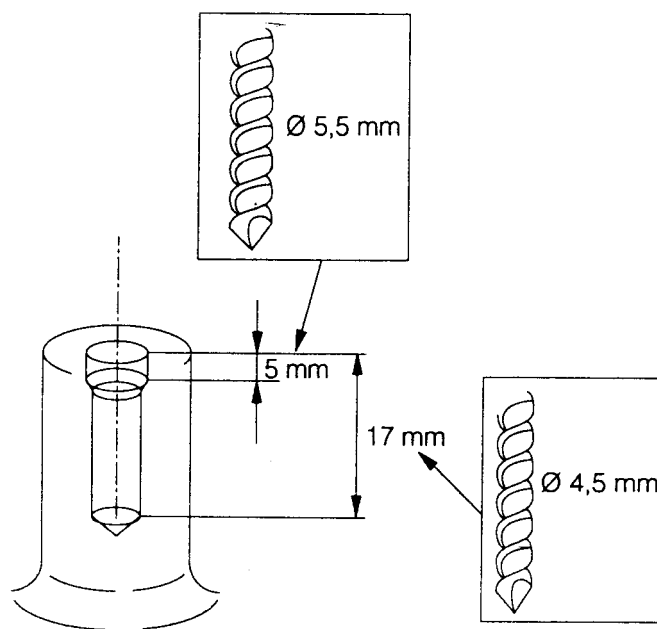

Both starters keep their earlier Ref. Nos. but get a new manufacturing code.
40/45 = T and 51 /55 = Q.

Introduced from serial Nos.:

51 = 132 1884

55 = 133 1650