





<b>SERVICE</b> 		<b>8</b>
		<b>B0100033</b>

English 1 (2)

## SB, 325 HDA 55, Angle adjustment and blades, 2001-06

Further improvements have been made to the angle adjustment mechanism on the 325 HDA 55. This means that certain parts are not interchangeable between the old and new versions.

If the gear housing, art. no. 537 17 33-01, is replaced on a cutter bar with a serial number lower than V259999, then the spacer washer, art. no. 537 18 48-01, must be replaced at the same time.

The thread on the cutter bar adjustment screws has also been changed from UNF 1/4" to M6.

Note that the serial number given is for the cutter bar, not the machine itself.

New part no.	Description	Excl. part no.	Remark
537 17 99-01	Spacer	505 51 98-01	*
537 18 48-01	Spacer washer	537 17 32-01	*
537 18 44-01	Support bar M6	537 12 24-01	*
537 18 45-01	Screw M6	501 36 48-78	*
537 18 46-01	Screw M6	537 12 37-01	*
537 18 47-01	Nut M6	501 36 11-88	*

\*Still available as spare part

Introduced from serial number: 325HDA55 W124506

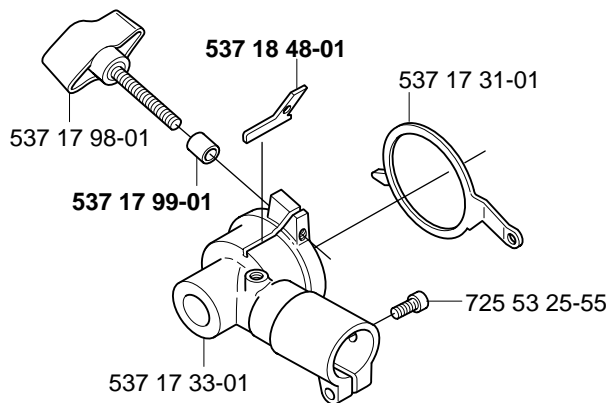

Serial number onwards W124506

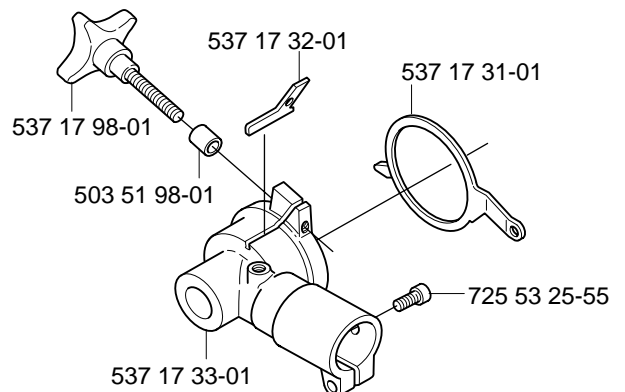

Up to and including serial number V259999

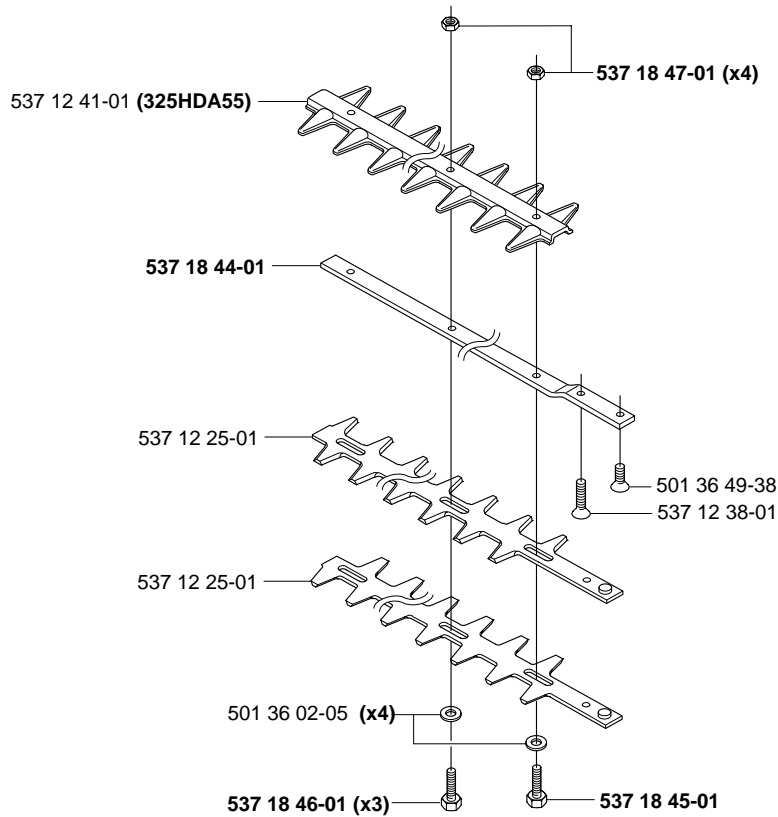

Serial number onwards W124506

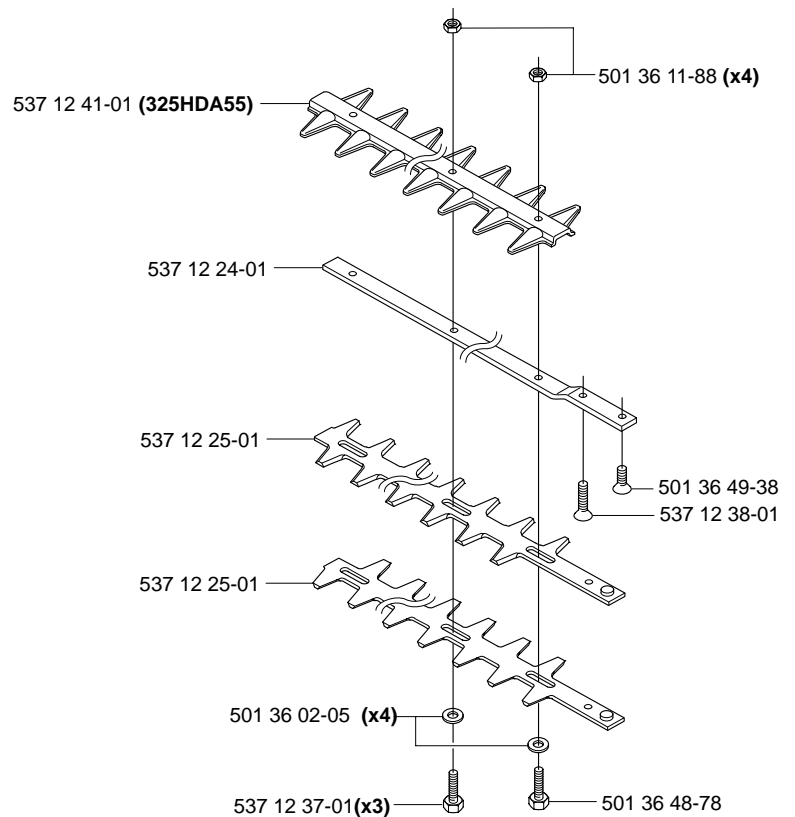

Up to and including serial number V259999