

For Husqvarna Parts Call 606-678-9623 or 606-561-4983

TUFF TORQ
TRANSAXLE
PARTS LIST

ISSUED 20. MAY 1996.

MODEL
K61I (HUSQ USA)

PARTS INDEX

All parts of this Parts List is arranged by Part No. order (depending on the spot where the part is used). If you want to know by Part No. where your object part is used, please use this Part List.

PARTS INDEX

Part No.	Description	Ref. No.	Page	Part No.	Description	Ref. No.	Page
192154-24090	TRANSAXLE CASE SET	1- 2	4	192154-25310	RING 15	4-10	10
192154-24101	UPPER CASE COMP.	1- 3	4	192154-25310	RING 15	12- 1	26
192154-24121	UPPER CASE	1- 4	4	192154-25310	RING 15	3- 8	8
192154-24171	LOWER CASE	1- 6	4	192154-27051	THRUST METAL	5- 1	12
192154-24212	HOUSING	4- 1	10	192154-27100	SWASH PLATE CMP	5- 2	12
192154-24240	BEARING(THRUST	4- 2	10	192154-27120	SWASH PLATE	5- 3	12
192154-24310	BOLT 8x75	1- 7	4	192154-27150	SWASH PLATE BUSHING	5- 4	12
192154-24360	MAGNET, CMP	1- 8	4	192154-27190	BEARING K81106	5- 5	12
192154-24370	HOLDER , MAGNET	1- 9	4	192154-27200	THRUST PLATE(A	5- 6	12
192154-24380	MAGNET 30x5	1-10	4	192154-27210	THRUST PLATE(B	5- 7	12
192154-24450	KNOCK PIN 12x22	2- 3	6	192154-27250	ARM (C	5- 8	12
192154-24531	CENTER CASE	2- 4	6	192154-27280	SPRING	5- 9	12
192154-24611	VALVE(A-1 SET	2- 5	6	192154-27290	SHAFT (BYPASS	5-10	12
192154-24620	VALVE(A-2 SET	2-16	6	192154-27301	BLOCK(SHIFT	5-12	12
192154-24641	SLEEVE(A-1	2-13	6	192154-27321	BLOCK SET	5-11	12
192154-24650	SLEEVE(A2	2-17	6	192154-29500	ROD(BYPASS	6- 1	14
192154-24660	BODY(B BYPASS	2-25	6	192154-29521	ARM (VALVE RELEASE	6- 2	14
192154-24660	BODY(B BYPASS	2-14	6	192154-29630	BUSHING	8-18	18
192154-24670	PACKING 1015	2- 6	6	192154-29702	FULCRUM(ECCENTRICITY	7- 1	16
192154-24670	PACKING 1015	2-18	6	192154-29720	SPRING(TORSION	7- 4	16
192154-24680	BACK-UP RING	2-19	6	192154-29850	RETURN SP(BRAKE	8- 1	18
192154-24680	BACK-UP RING	2- 7	6	192154-29860	BRAKE ROD CMP	8- 8	18
192154-24690	HOLDER (BYPASS	2- 8	6	192154-29870	ARM (BRAKE	8- 2	18
192154-24690	HOLDER(BYPASS	2-20	6	192154-29880	ADJUSTER CMP	8- 9	18
192154-24701	SPRING	2- 9	6	192154-29890	SPRING GUIDE	8-10	18
192154-24701	SPRING	2-21	6	192154-29900	BAND BRAKE(INTERLOCK	12- 2	26
192154-24710	PUSH PIN	2-10	6	192154-29910	SHAFT(BRAKE	8- 7	18
192154-24710	PUSH PIN	2-22	6	192154-29920	ROD(BRAKE	8- 3	18
192154-24720	SPRING	2-11	6	192154-29930	ARM A(BRAKE	8- 4	18
192154-24720	SPRING	2-23	6	192154-29950	HOLDER(SPRING	8-11	18
192154-24730	HOLDER (BALL	2-12	6	192154-29960	SPRING	8-13	18
192154-24730	HOLDER (BALL	2-24	6	192154-29970	ARM B(BRAKE	8- 5	18
192154-24910	CONNECTOR	2- 1	6	192154-29990	ROD(ADJUSTER	8-12	18
192154-24970	FILTER	2-28	6	192154-31521	DIFF. SIDE GEAR	9- 3	20
192154-25120	CYLINDER BLOCK	3- 2	8	192154-31530	THRUST WASHER (DIFF.	9- 1	20
192154-25120	CYLINDER BLOCK	4- 4	10	192154-31810	SHAFT(DIFF. PINION	9- 5	20
192154-25140	CYLINDER BLOCK CMP	3- 1	8	192154-33410	SHAFT (FINAL PINION	10- 1	22
192154-25140	CYLINDER BLOCK CMP	4- 3	10	192154-33420	WASHER 15x32x1	10- 2	22
192154-25150	PISTON	4- 5	10	192154-33430	BUSHING 15	10- 3	22
192154-25150	PISTON	3- 3	8	192154-33440	GEAR 51(FINAL SHAFT	10- 4	22
192154-25170	WASHER 11	4- 6	10	192154-33520	FINAL GEAR 55	9- 6	20
192154-25170	WASHER 11	3- 4	8	192154-34122	AXLE SHAFT L	11- 5	24
192154-25190	SPRING(PISTON	3- 5	8	192154-34222	AXLE SHAFT R	11- 6	24
192154-25190	SPRING (PISTON	4- 7	10	192154-34240	BUSHING 25. 4	1- 5	4
192154-25200	SPRING	3- 6	8	192154-34250	BUSHING 22	11- 1	24
192154-25200	SPRING	4- 8	10	192154-34270	SEAL (S25. 4x42x8	11- 2	24
192154-25210	WASHER 15x20x1	3- 7	8	192154-34290	RING 20	11- 3	24
192154-25210	WASHER 15x20x1	4- 9	10	192154-34311	THRUST WASHER	11- 4	24
192154-25260	PUMP SHAFT	3- 9	8	192154-36160	BRAKE DRUM	12- 3	26
192154-25270	SHAFT (MOTOR 13	4-11	10	192154-84520	CENTER CASE CMP B	2- 2	6

PARTS INDEX

Part No.	Description	Ref. No.	Page	Part No.	Description	Ref. No.	Page
192154-89061	INPUT SHEAVE	13- 1	28				
192154-89150	SHOCK ABSORBER	13- 1	28				
192154-89710	CONTROL SHAFT	7- 3	16				
192154-89760	RING 16	7- 9	16				
192154-89800	CONTROL SHAFT CMP	7- 2	16				
192163-31501	DIFF. GEAR KIT	9- 2	20				
192163-31610	DIFF. PINION	9- 4	20				
194855-24020	SEALANT	1- 1	4				
1C6281-52310	PIN, SNAP	8- 6	18				
22137-060000	WASHER 6	8-14	18				
22137-120000	WASHER 12	7- 5	16				
22190-080000	WASHER, SEAL 8	1-11	4				
22252-000350	RING 35	1-12	4				
22272-000060	RING 6	8-19	18				
22351-040025	PIN 4. 0A×25	6- 3	14				
22351-060040	PIN 6. 0A×40	8-15	18				
22417-200200	PIN 2. 0×20	8-16	18				
23871-010000	PLUG PT1/8	2-29	6				
24101-062020	BEARING 6202C3	3-10	8				
24101-062020	BEARING 6202C3	4-12	10				
24101-062034	BEARING 6203	10- 5	22				
24190-120001	BALL 3/8	2-15	6				
24190-120001	BALL 3/8	2-26	6				
24311-000070	PACKING P 7	5-13	12				
24311-000110	PACKING P 11	2-30	6				
24311-000120	PACKING P 12	8-17	18				
24311-000120	PACKING P 12	7- 6	16				
24311-000140	PACKING P 14	2-31	6				
24311-240100	PACKING P 10A	7- 7	16				
24421-153507	SEAL TC153507	1-13	4				
24421-173507	SEAL TC173507	1-14	4				
24550-012120	BEARING 12×2	2-27	6				
26016-080202	BOLT W/WASHER 8×20	12- 4	26				
26106-080122	BOLT 8×12	1-15	4				
26106-100602	BOLT 10×60	2-32	6				
26476-080302	TAPPING, SCREW 8×30	1-16	4				
26476-080402	TAPPING, SCREW 8×40	1-17	4				
26776-120002	NUT 12	7- 8	16				
792154-84080	TRANSAXLE ASSY	0- 1	2				

CONTENTS

		Page
Fig. 0	TRANSAXLE KIT ASSY	1
Fig. 1	TRANSAXLE CASE ASSY	3
Fig. 2	CENTER CASE ASSY	5
Fig. 3	PUMP SHAFT ASSY	7
Fig. 4	MOTOR SHAFT ASSY	9
Fig. 5	RANGE SHIFT ASSY	11
Fig. 6	BYPASS RETURN ASSY	13
Fig. 7	N-CENTERING ASSY	15
Fig. 8	BRAKE INTERLOCK ASSY	17
Fig. 9	DIFF. GEAR ASSY	19
Fig. 10	FINAL PINION ASSY	21
Fig. 11	AXLE SHAFT ASSY	23
Fig. 12	BRAKE ASSY	25
Fig. 13	OPTION ASSY	27

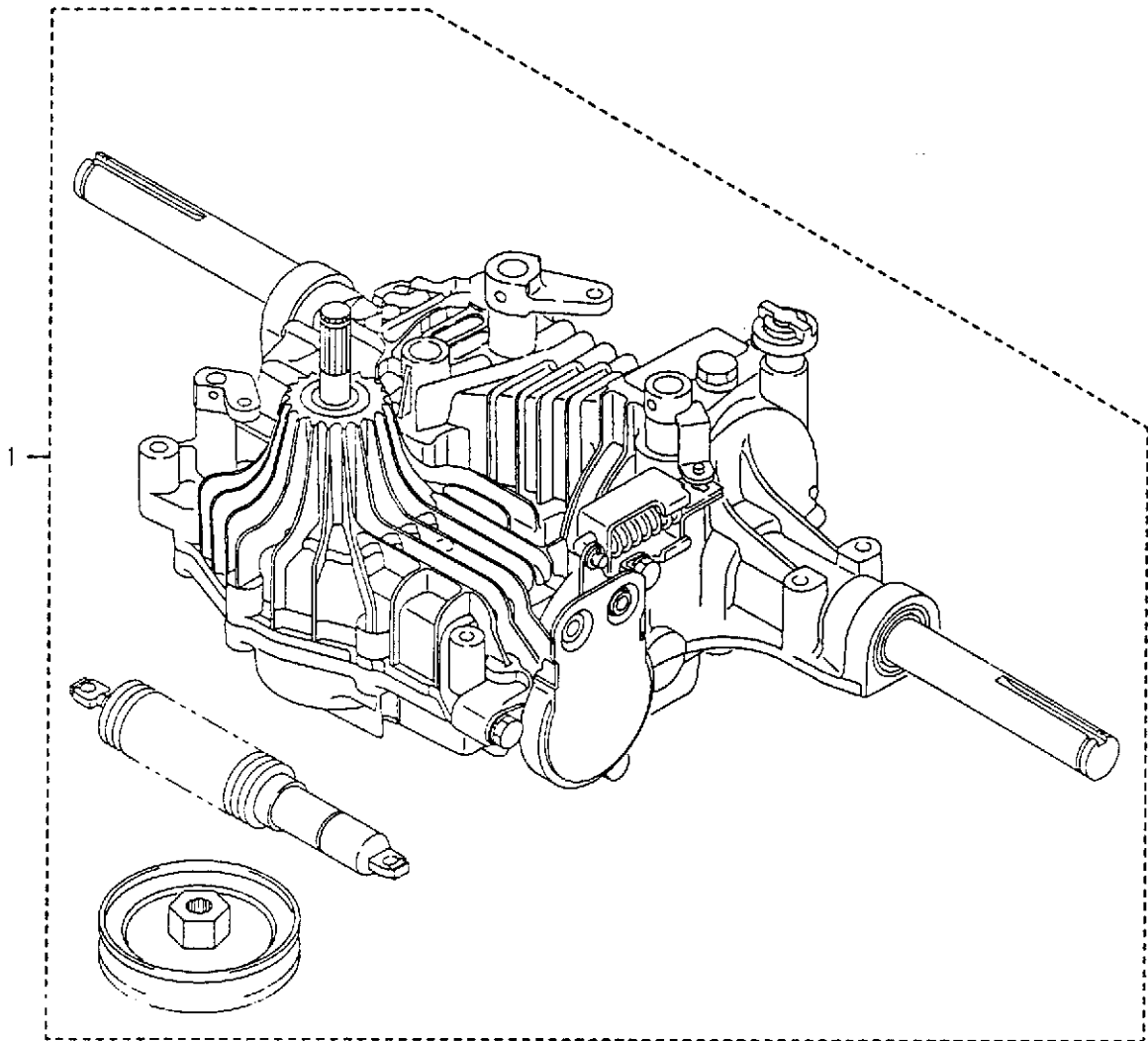

Fig.1 TRANSAXLE CASE ASSY

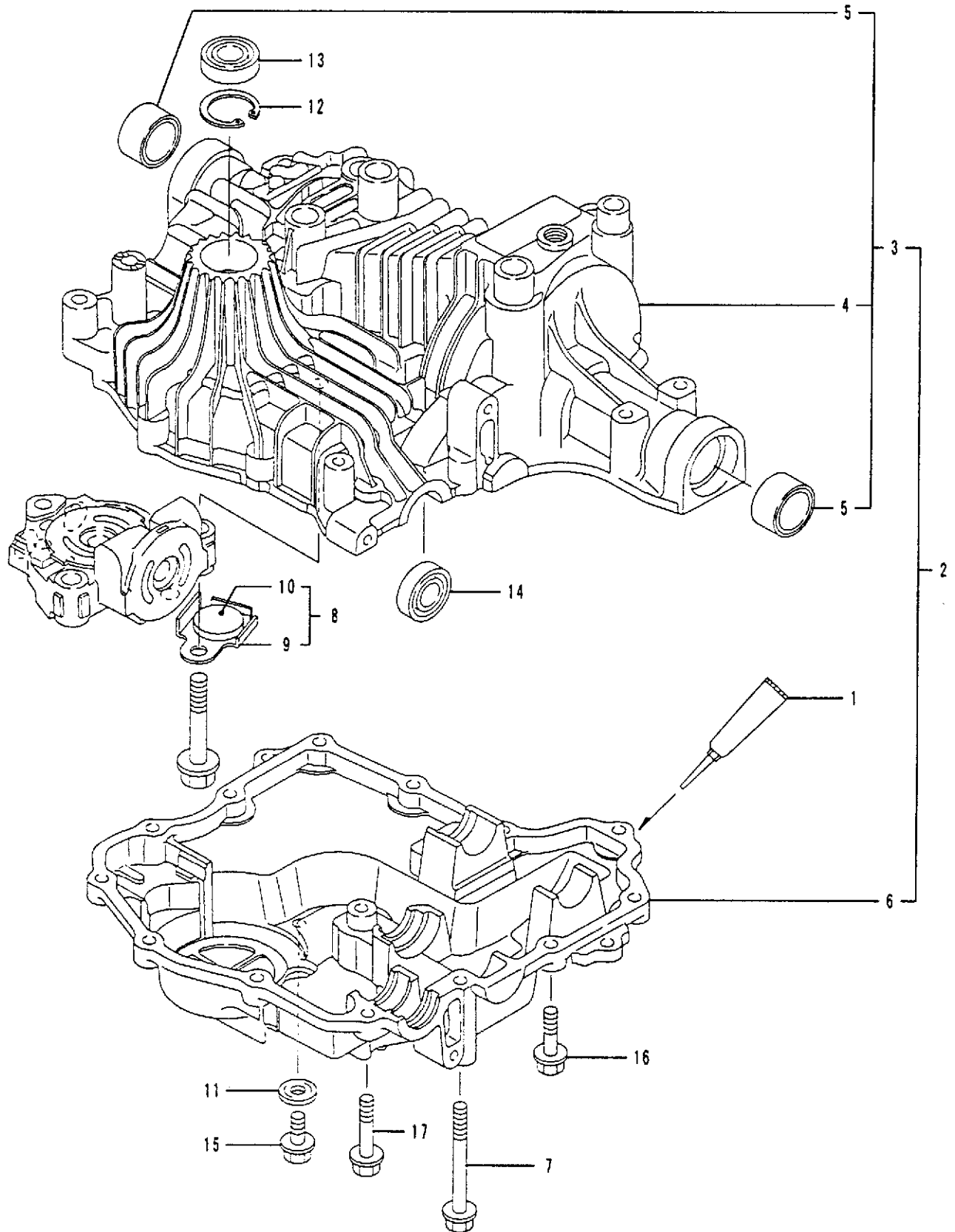
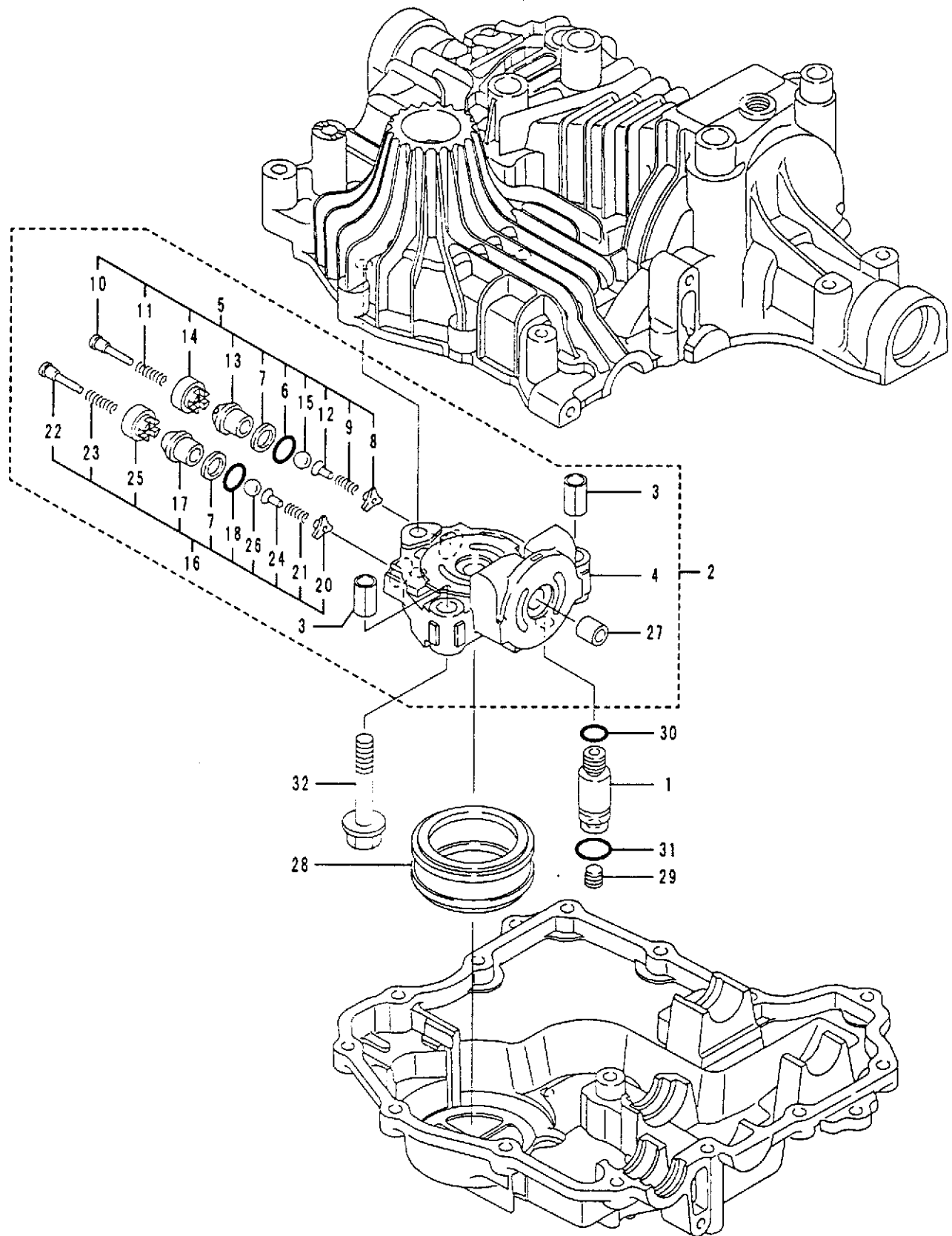

Fig.1 TRANSAXLE CASE ASSY

(D92154-24110)

Ref. No.	Level	Description	Part No.	Q' ty/Unit			Service	Remarks
				K61				
1 - 1	.	SEALANT	194855-24020	1				
1 - 2	.	TRANSAXLE CASE SET	192154-24090	1				
1 - 3	..	UPPER CASE COMP.	192154-24101	1				
1 - 4	...	UPPER CASE	192154-24121	1			NO	
1 - 5	...	BUSHING 25.4	192154-34240	2			NO	
1 - 6	..	LOWER CASE	192154-24171	1				
1 - 7	.	BOLT 8×75	192154-24310	1				
1 - 8	.	MAGNET, CMP	192154-24360	1				
1 - 9	..	HOLDER , MAGNET	192154-24370	1			NO	
1 - 10	..	MAGNET 30×5	192154-24380	1			NO	
1 - 11	.	WASHER, SEAL 8	22190-080000	1				
1 - 12	.	RING 35	22252-000350	1				
1 - 13	.	SEAL TC153507	24421-153507	1				
1 - 14	.	SEAL TC173507	24421-173507	1				
1 - 15	.	BOLT 8×12	26106-080122	1				
1 - 16	.	TAPPING, SCREW 8×30	26476-080302	11				
1 - 17	.	TAPPING, SCREW 8×40	26476-080402	2				

Fig.2 CENTER CASE ASSY



Ref. No.	Level	Description	Part No.	Q' ty/Unit			Service	Remarks
				K61				
2 - 1	.	CONNECTOR	192154-24910	1				
2 - 2	.	CENTER CASE CMP B	192154-84520	1				
2 - 3	..	KNOCK PIN 12×22	192154-24450	2				
2 - 4	..	CENTER CASE	192154-24531	1			NO	
2 - 5	..	VALVE(A-1 SET	192154-24611	1				
2 - 6	...	PACKING 1015	192154-24670	1				
2 - 7	...	BACK-UP RING	192154-24680	1				
2 - 8	...	HOLDER (BYPASS	192154-24690	1			NO	
2 - 9	...	SPRING	192154-24701	1			NO	
2 - 10	...	PUSH PIN	192154-24710	1			NO	
2 - 11	...	SPRING	192154-24720	1			NO	
2 - 12	...	HOLDER (BALL	192154-24730	1			NO	
2 - 13	...	SLEEVE(A-1	192154-24641	1			NO	
2 - 14	...	BODY(B BYPASS	192154-24660	1			NO	
2 - 15	...	BALL 3/8	24190-120001	1			NO	
2 - 16	..	VALVE(A-2 SET	192154-24620	1				
2 - 17	...	SLEEVE(A2	192154-24650	1			NO	
2 - 18	...	PACKING 1015	192154-24670	1				
2 - 19	...	BACK-UP RING	192154-24680	1				
2 - 20	...	HOLDER (BYPASS	192154-24690	1			NO	
2 - 21	...	SPRING	192154-24701	1			NO	
2 - 22	...	PUSH PIN	192154-24710	1			NO	
2 - 23	...	SPRING	192154-24720	1			NO	
2 - 24	...	HOLDER (BALL	192154-24730	1			NO	
2 - 25	...	BODY(B BYPASS	192154-24660	1			NO	
2 - 26	...	BALL 3/8	24190-120001	1			NO	
2 - 27	..	BEARING 12×2	24550-012120	2				
2 - 28	.	FILTER	192154-24970	1				
2 - 29	.	PLUG PT1/8	23871-010000	1				
2 - 30	.	PACKING P 11	24311-000110	1				
2 - 31	.	PACKING P 14	24311-000140	1				
2 - 32	.	BOLT 10×60	26106-100602	3				

Fig.3 PUMP SHAFT ASSY

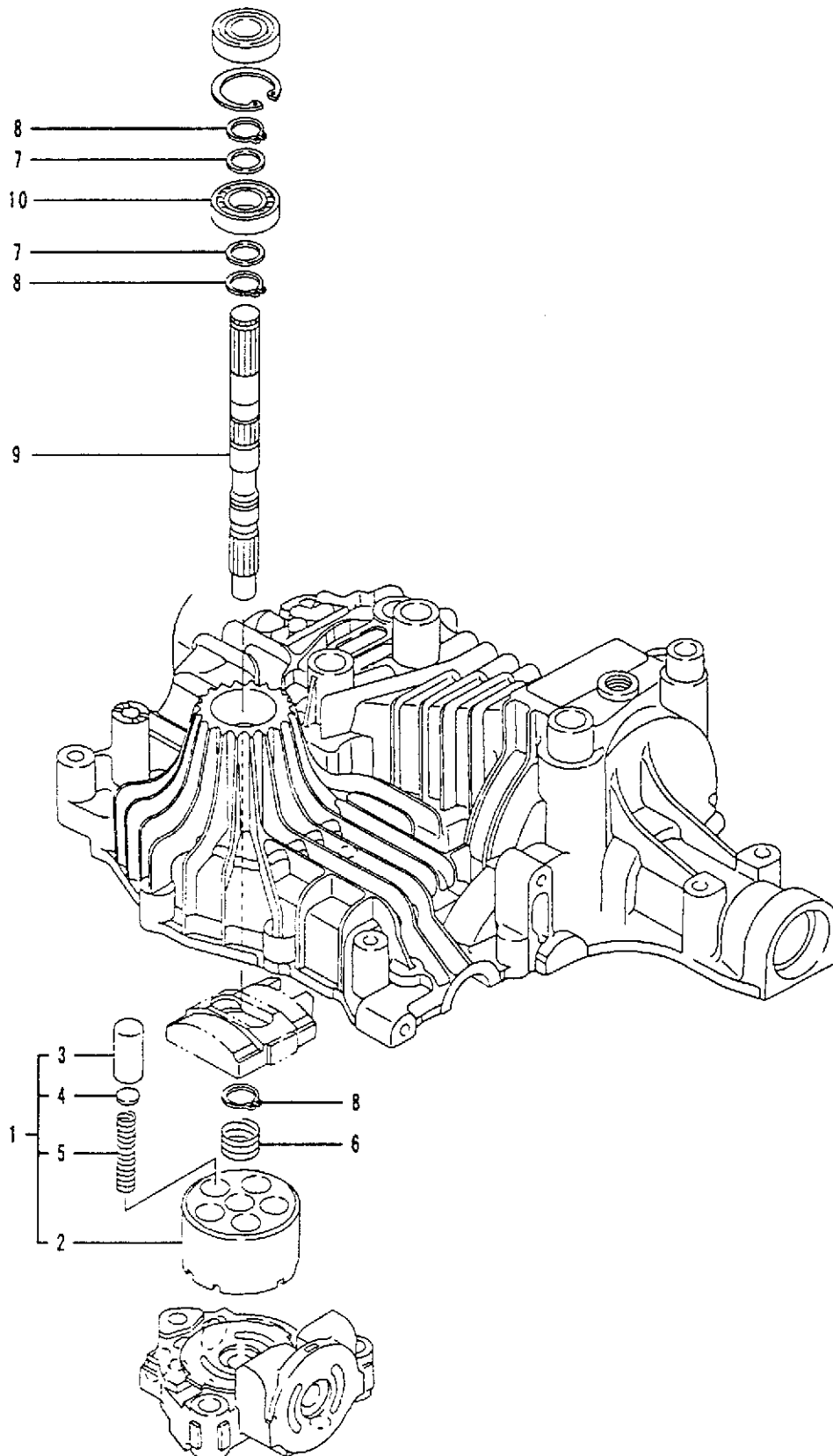

Ref. No.	Level	Description	Part No.	Q'ty/Unit		Service	Remarks
				K61			
3 - 1	.	CYLINDER BLOCK CMP	192154-25140	1			
3 - 2	..	CYLINDER BLOCK	192154-25120	1		NO	
3 - 3	..	PISTON	192154-25150	5		NO	
3 - 4	..	WASHER 11	192154-25170	5		NO	
3 - 5	..	SPRING (PISTON	192154-25190	5		NO	
3 - 6	.	SPRING	192154-25200	1			
3 - 7	.	WASHER 15×20×1	192154-25210	2			
3 - 8	.	RING 15	192154-25310	3			
3 - 9	..	PUMP SHAFT	192154-25260	1			
3 - 10	.	BEARING 6202C3	24101-062020	1			

Fig.4 MOTOR SHAFT ASSY

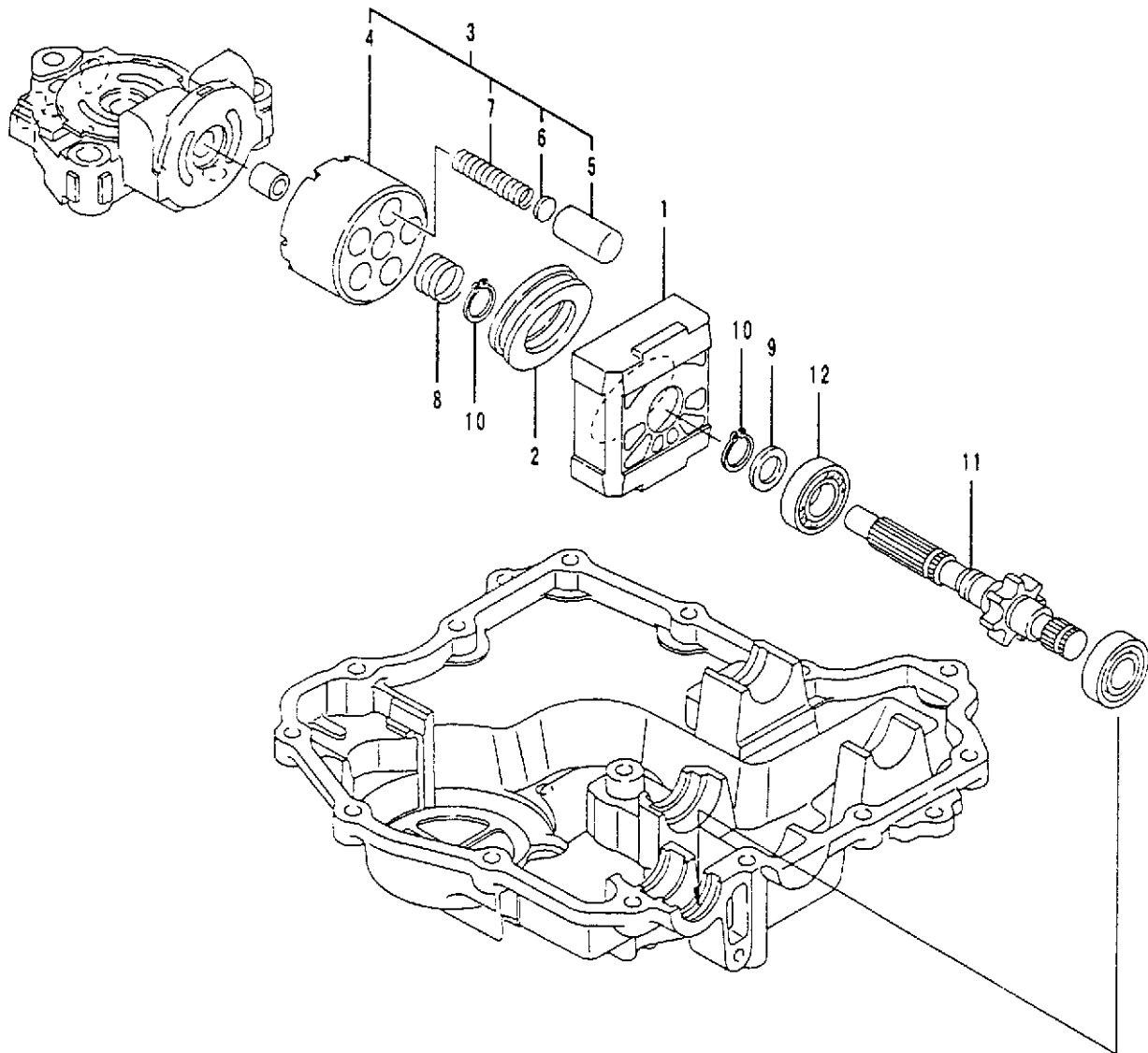
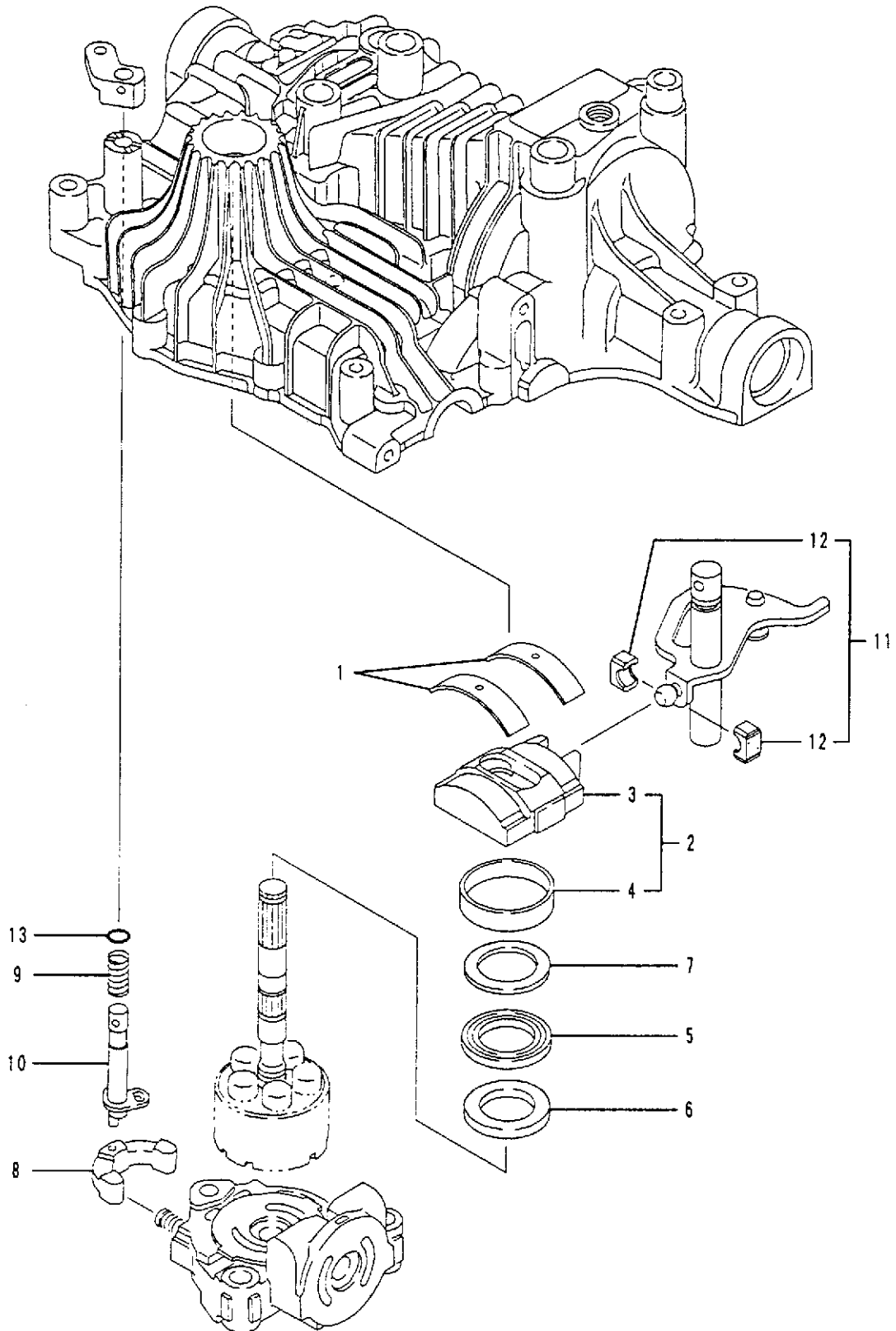

Fig.4 MOTOR SHAFT ASSY

(D92154-25210)

Ref. No.	Level	Description	Part No.	Q'ty/Unit		Service	Remarks
				K61			
4-1	.	HOUSING	192154-24212	1			
4-2	.	BEARING (THRUST	192154-24240	1			
4-3	.	CYLINDER BLOCK CMP	192154-25140	1			
4-4	..	CYLINDER BLOCK	192154-25120	1		NO	
4-5	..	PISTON	192154-25150	5		NO	
4-6	..	WASHER 11	192154-25170	5		NO	
4-7	..	SPRING (PISTON	192154-25190	5		NO	
4-8	.	SPRING	192154-25200	1			
4-9	.	WASHER 15×20×1	192154-25210	1			
4-10	.	RING 15	192154-25310	2			
4-11	.	SHAFT (MOTOR 13	192154-25270	1			
4-12	.	BEARING 6202C3	24101-062020	1			

Fig.5 RANGE SHIFT ASSY



Ref. No.	Level	Description	Part No.	Q'ty/Unit		Service	Remarks
				K61			
5 - 1	.	THRUST METAL	192154-27051	2			
5 - 2	.	SWASH PLATE CMP	192154-27100	1			
5 - 3	..	SWASH PLATE	192154-27120	1		NO	
5 - 4	..	SWASH PLATE BUSHING	192154-27150	1		NO	
5 - 5	.	BEARING K81106	192154-27190	1			
5 - 6	.	THRUST PLATE(A	192154-27200	1			
5 - 7	.	THRUST PLATE(B	192154-27210	1			
5 - 8	.	ARM (C	192154-27250	1			
5 - 9	.	SPRING	192154-27280	1			
5 - 10	.	SHAFT (BYPASS	192154-27290	1			
5 - 11	.	BLOCK SET	192154-27321	1			
5 - 12	..	BLOCK(SHIFT	192154-27301	2		NO	
5 - 13	.	PACKING P 7	24311-000070	1			

Fig.6 BYPASS RETURN ASSY

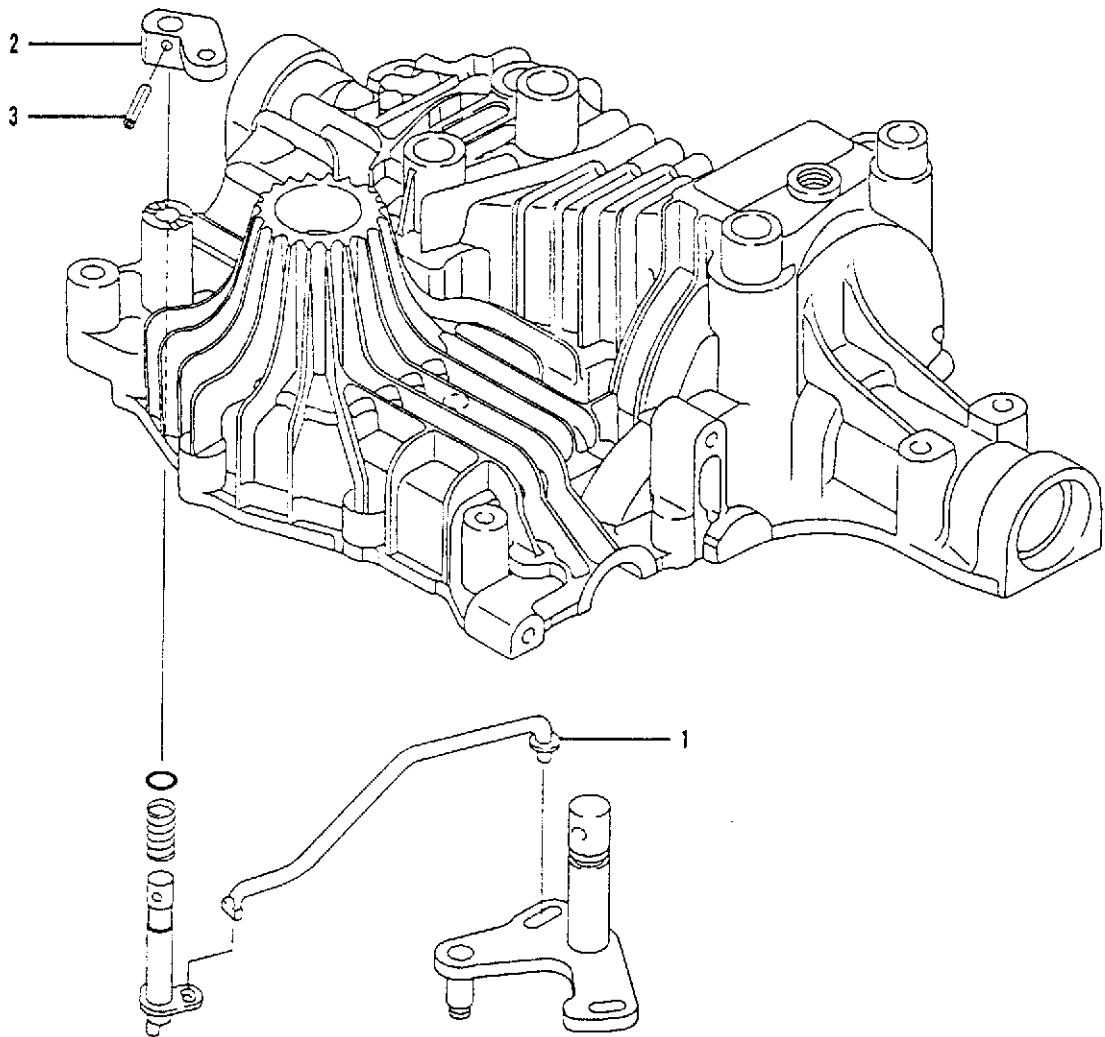
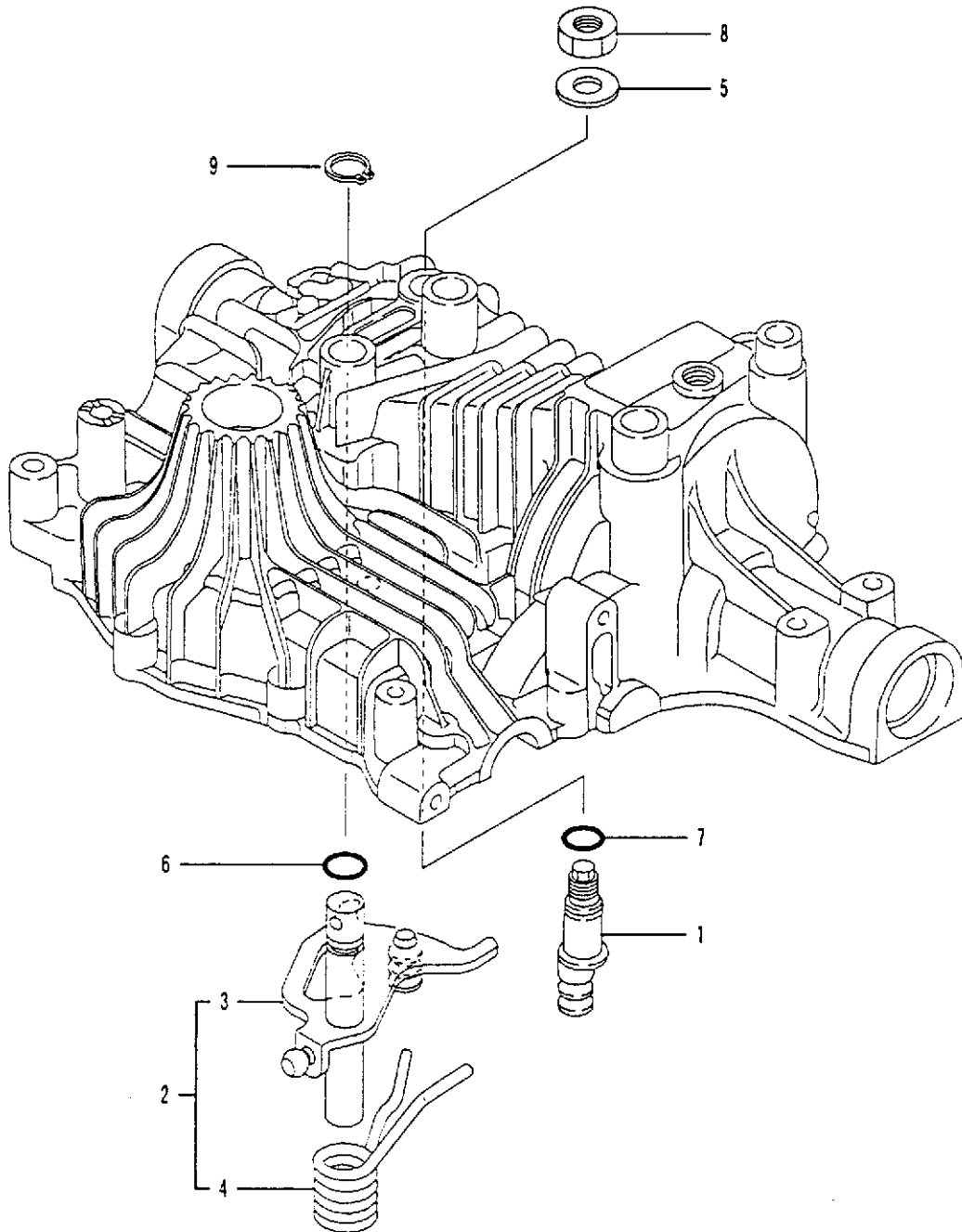

Fig.7 N-CENTERING ASSY



Ref. No.	Level	Description	Part No.	Q'ty/Unit		Service	Remarks
				K61			
7-1	.	FULCRUM(ECCENTRICITY	192154-29702	1			
7-2	.	CONTROL SHAFT CMP	192154-89800	1			
7-3	..	CONTROL SHAFT	192154-89710	1		NO	
7-4	..	SPRING(TORSION	192154-29720	1		NO	
7-5	.	WASHER 12	22137-120000	1			
7-6	.	PACKING P 12	24311-000120	1			
7-7	.	PACKING P 10A	24311-240100	1			
7-8	.	NUT 12	26776-120002	1			
7-9	.	RING 16	192154-89760	1			

Fig.8 BRAKE INTERLOCK ASSY

(D92154-29910)

Ref. No.	Level	Description	Part No.	Q' ty/Unit		Service	Remarks
				K61			
8 - 1	.	RETURN SP(BRAKE	192154-29850	1			
8 - 2	.	ARM (BRAKE	192154-29870	1			
8 - 3	.	ROD(BRAKE	192154-29920	1			
8 - 4	.	ARM A(BRAKE	192154-29930	1			
8 - 5	.	ARM B(BRAKE	192154-29970	1			
8 - 6	.	PIN, SNAP	1C6281-52310	1			
8 - 7	.	SHAFT(BRAKE	192154-29910	1			
8 - 8	.	BRAKE ROD CMP	192154-29860	1			
8 - 9	..	ADJUSTER CMP	192154-29880	1		NO	
8 - 10	..	SPRING GUIDE	192154-29890	1		NO	
8 - 11	..	HOLDER(SPRING	192154-29950	1		NO	
8 - 12	..	ROD(ADJUSTER	192154-29990	1		NO	
8 - 13	..	SPRING	192154-29960	1		NO	
8 - 14	.	WASHER 6	22137-060000	2			
8 - 15	.	PIN 6. 0A×40	22351-060040	2			
8 - 16	.	PIN 2. 0×20	22417-200200	1			
8 - 17	.	PACKING P 12	24311-000120	2			
8 - 18	.	BUSHING	192154-29630	1			
8 - 19	.	RING 6	22272-000060	1			

Fig.9 DIFF. GEAR ASSY

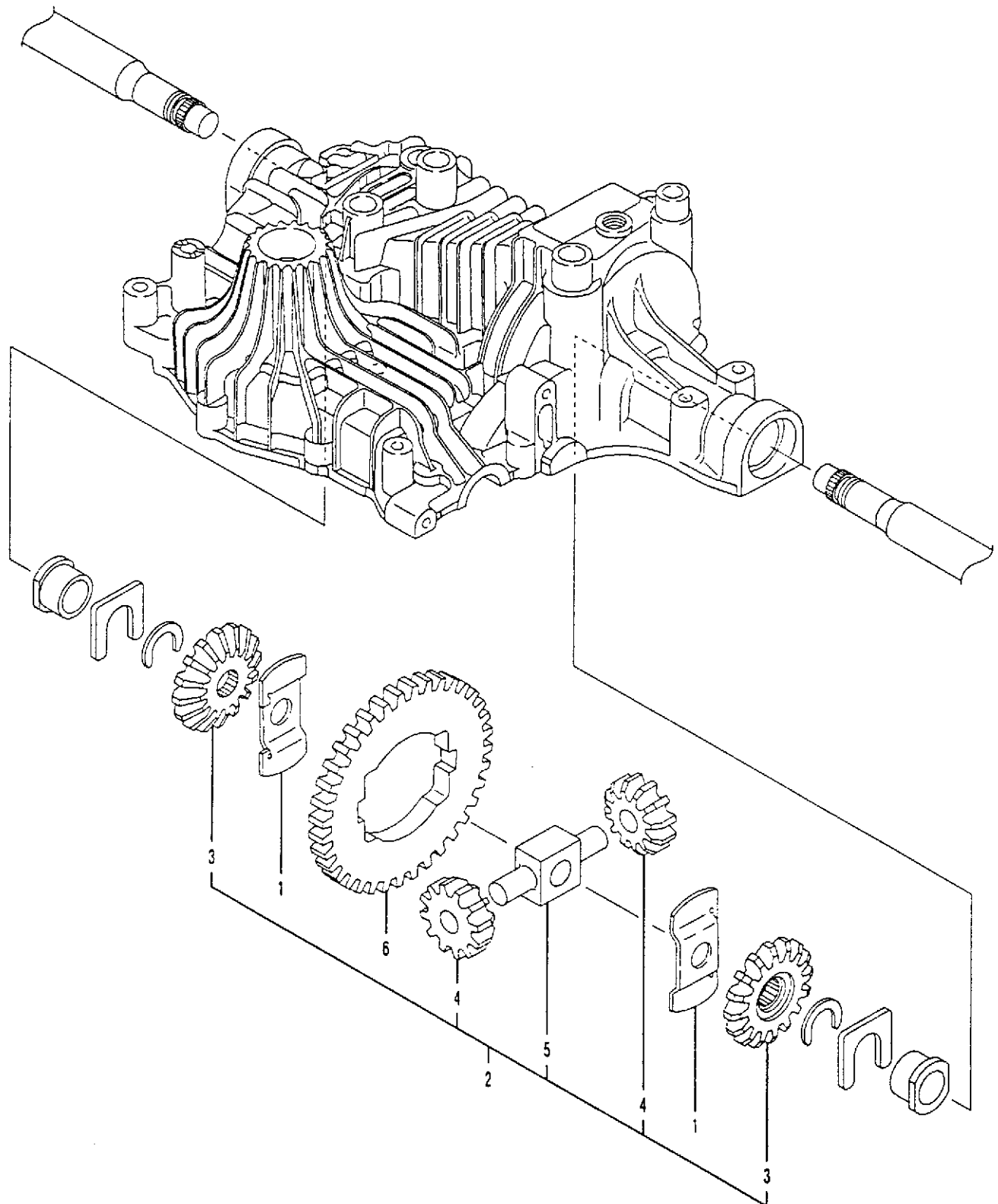

Fig.10 FINAL PINION ASSY

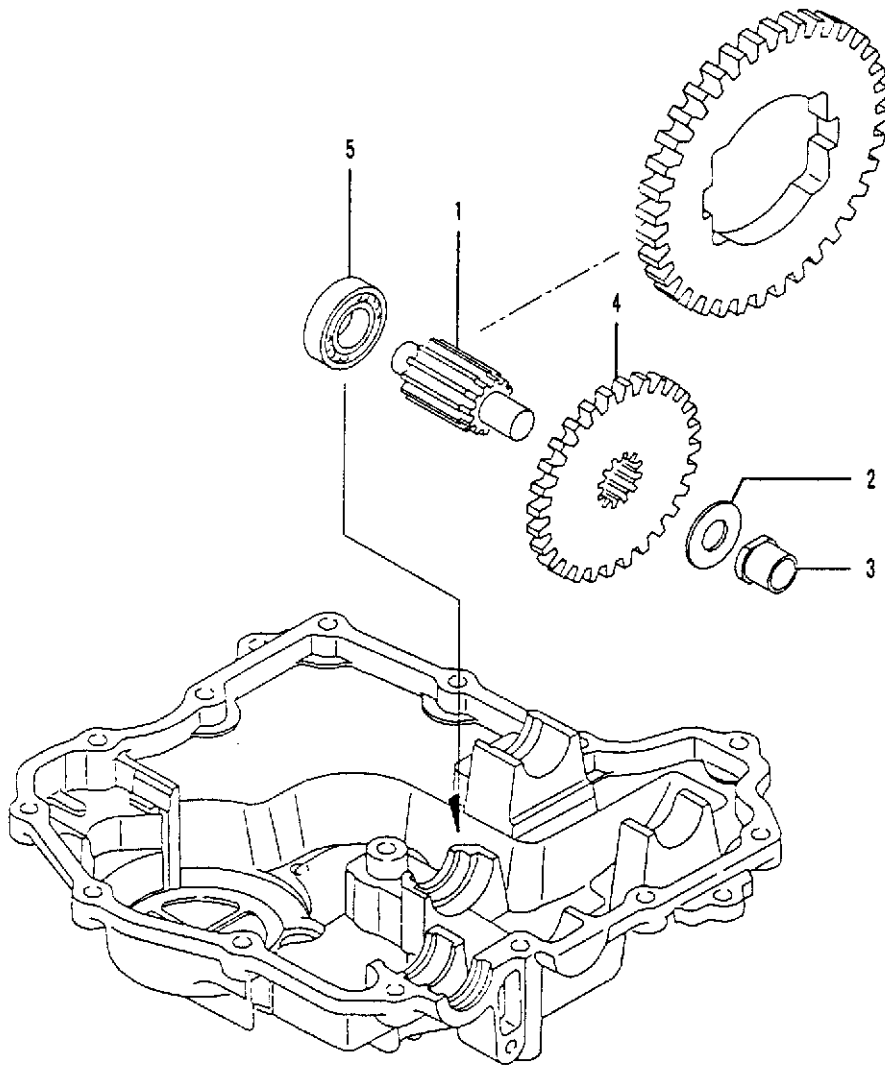

Fig.11 AXLE SHAFT ASSY

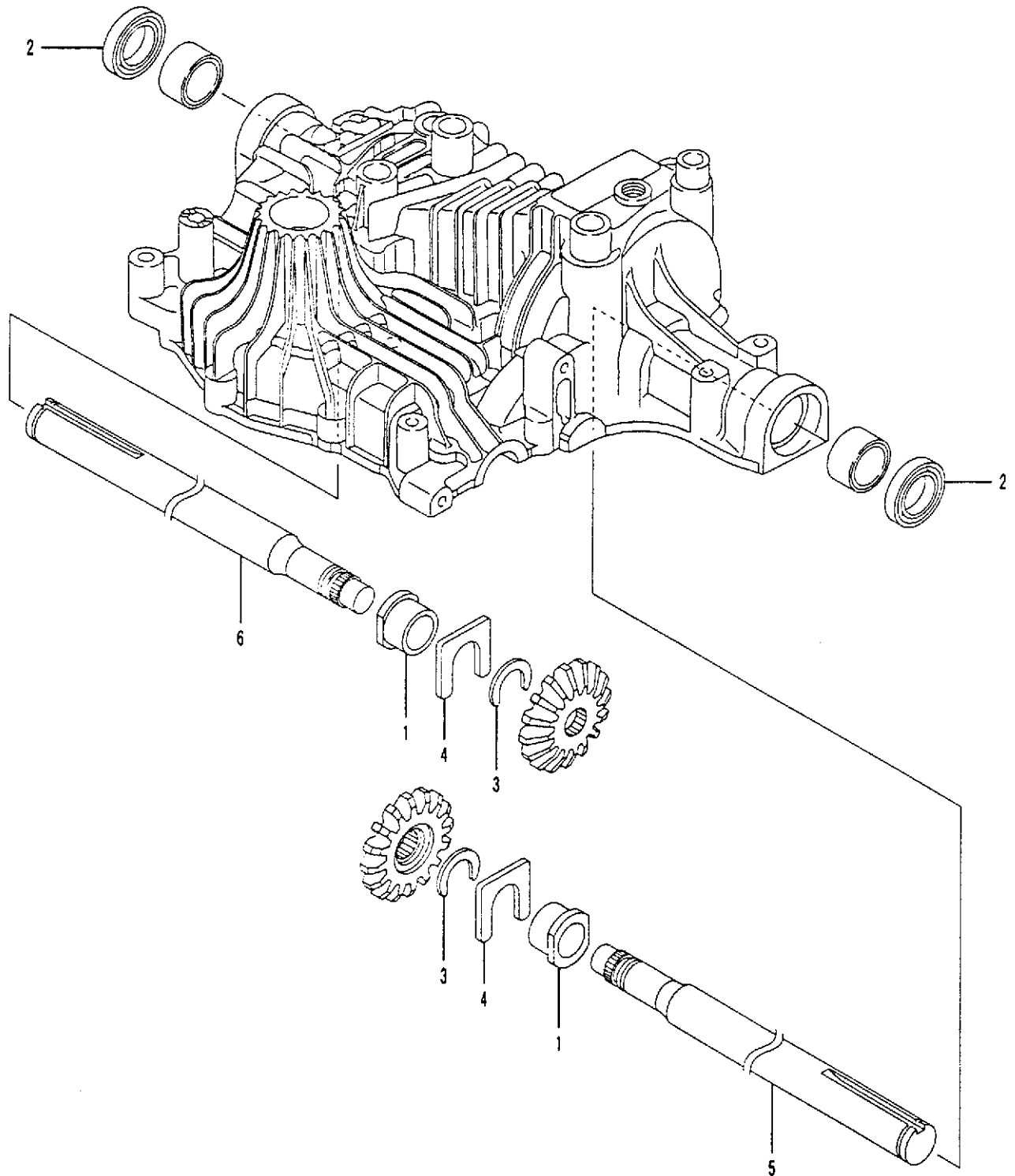

Fig.12 BRAKE ASSY

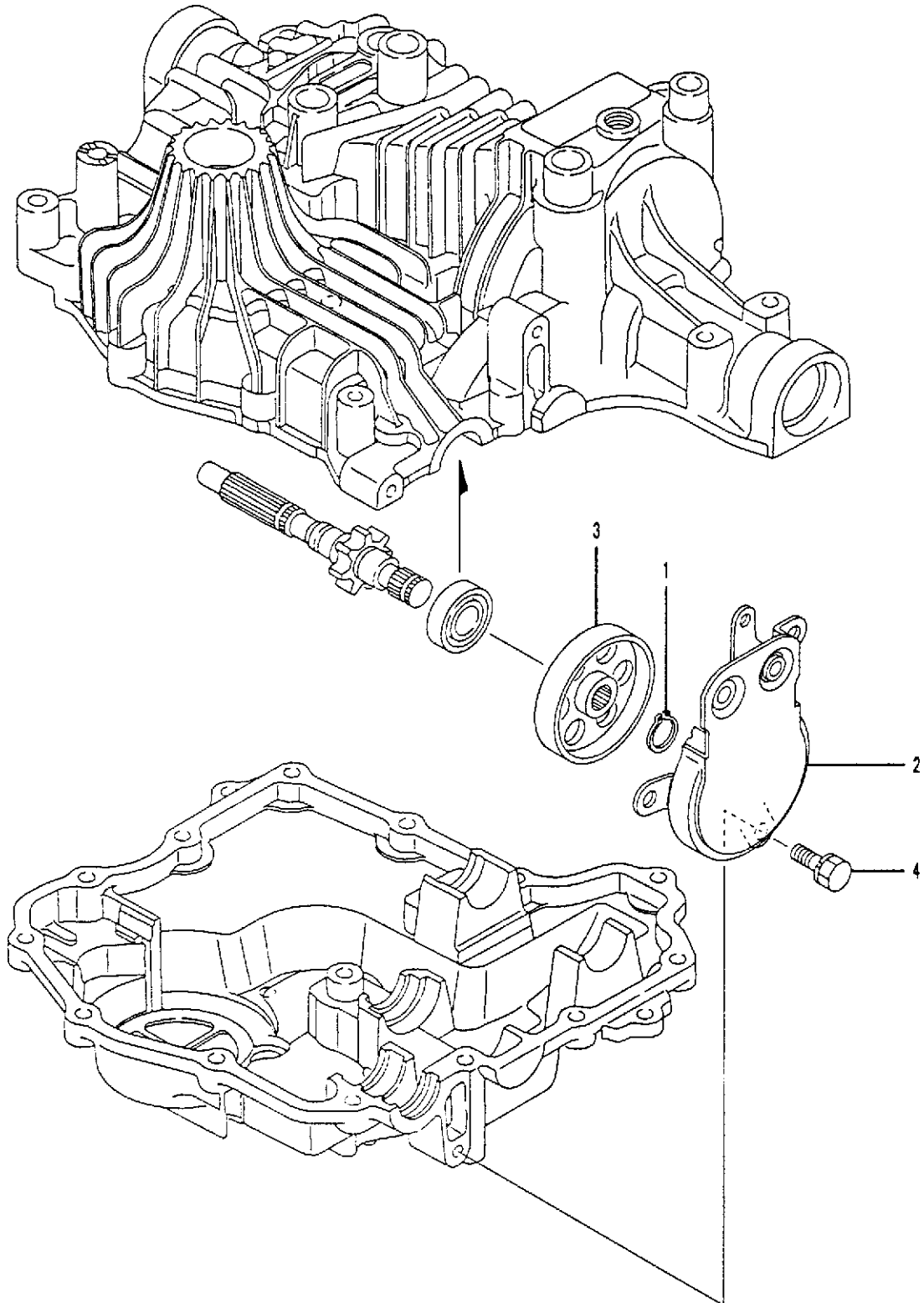
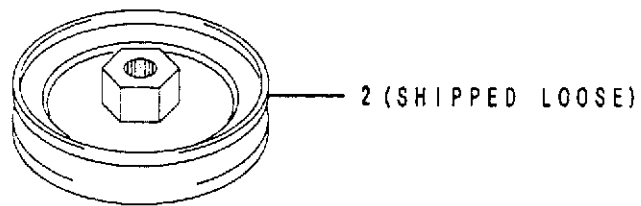
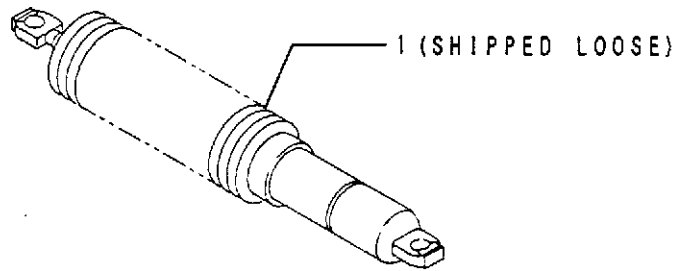

Fig.13 OPTION ASSY



For Husqvarna Parts Call 606-678-9623 or 606-561-4983



TUFF TORQ CORPORATION

5943 COMMERCE BOULEVARD, MORRISTOWN,
TENN., 37814 U.S.A.

TEL:(423)585-2000

FAX:(423)585-2003

www.mymowerparts.com