

For Husqvarna Parts Call 606-678-9623 or 606-561-4983

 **Husqvarna**

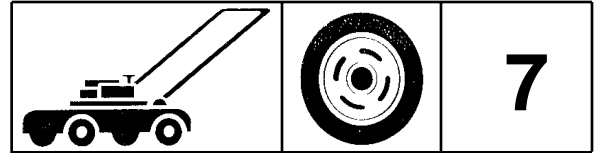

GT 200

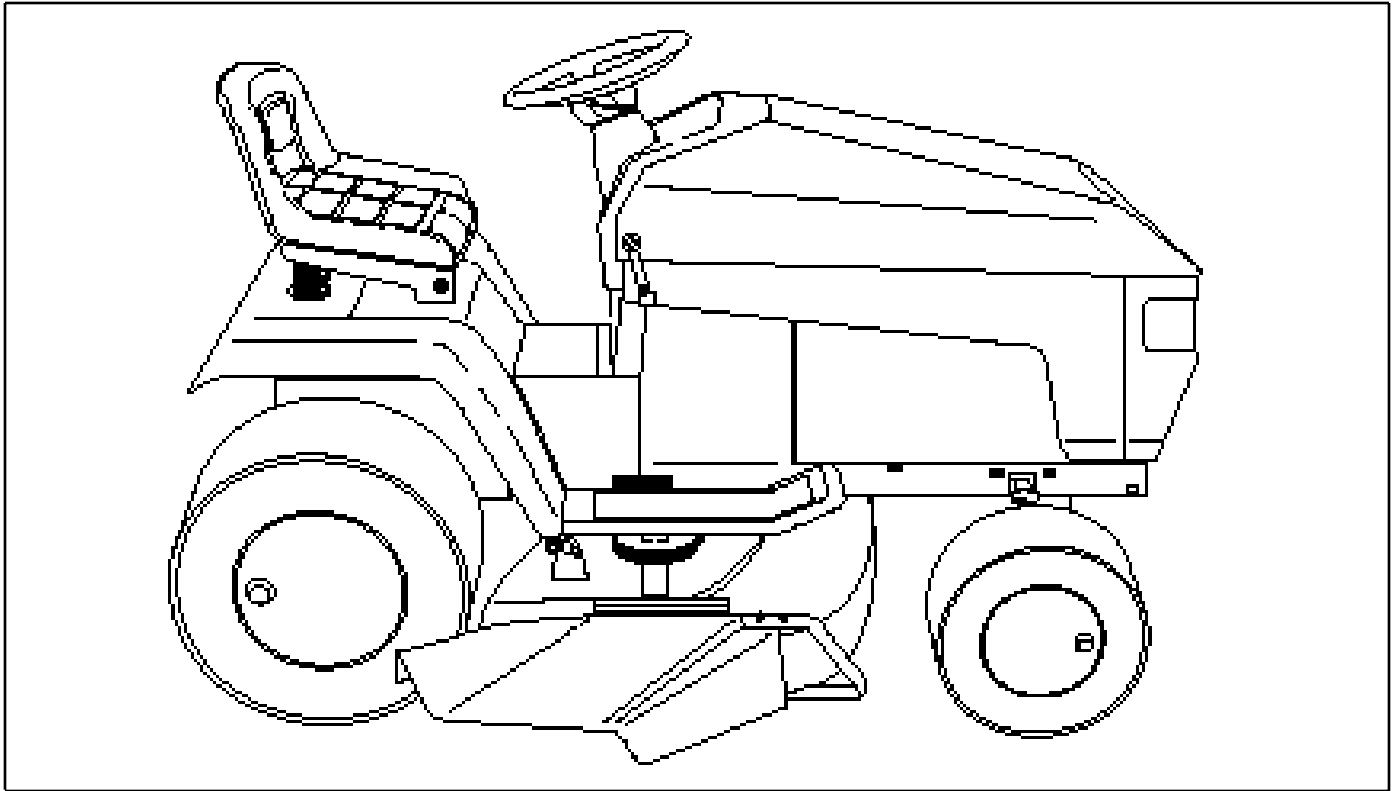

1.1997
Spare Parts

954 14 00-11A

SCHEMATIC

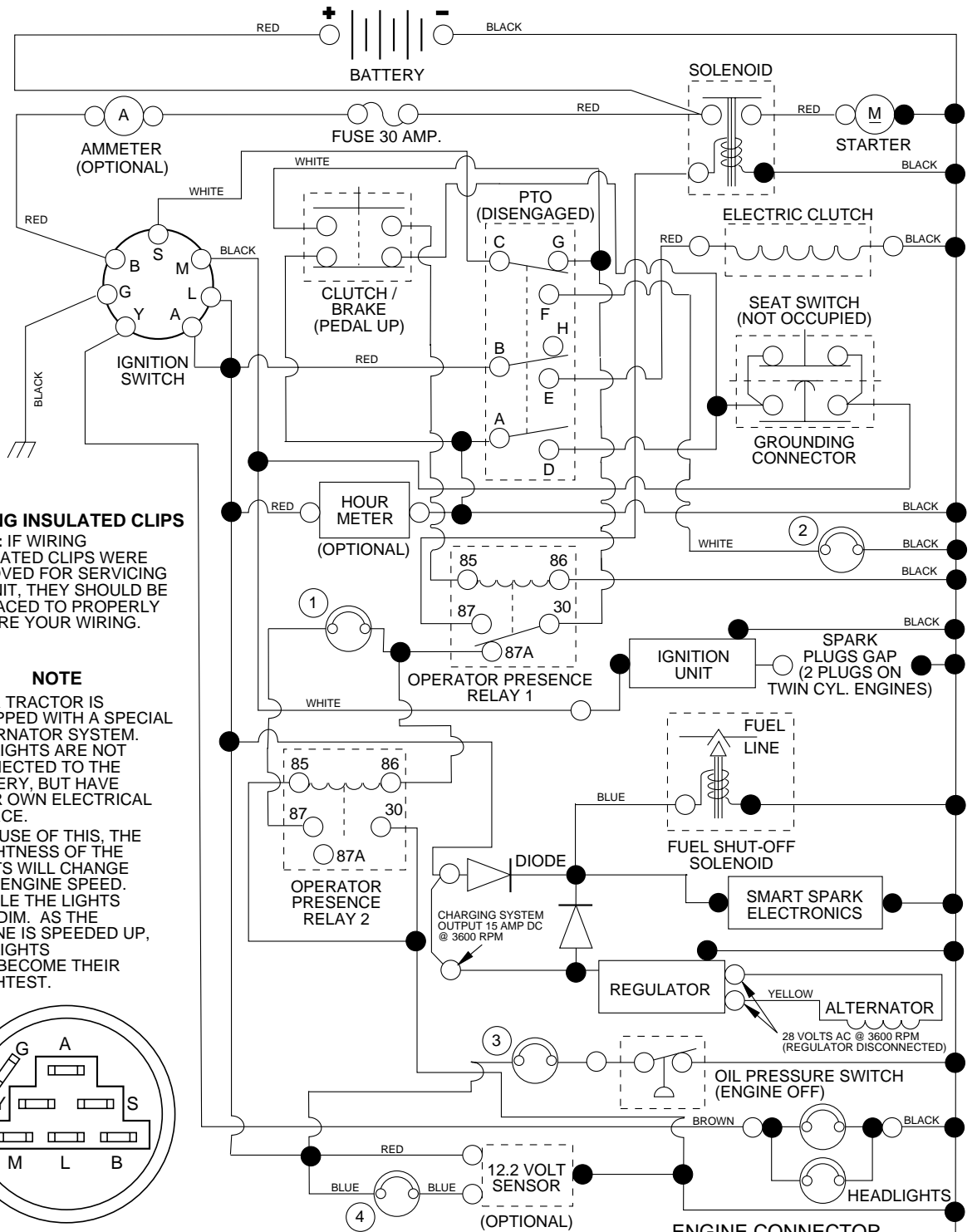

WIRING INSULATED CLIPS

NOTE: IF WIRING INSULATED CLIPS WERE REMOVED FOR SERVICING OF UNIT, THEY SHOULD BE REPLACED TO PROPERLY SECURE YOUR WIRING.

NOTE

YOUR TRACTOR IS EQUIPPED WITH A SPECIAL ALTERNATOR SYSTEM. THE LIGHTS ARE NOT CONNECTED TO THE BATTERY, BUT HAVE THEIR OWN ELECTRICAL SOURCE.

BECAUSE OF THIS, THE BRIGHTNESS OF THE LIGHTS WILL CHANGE WITH ENGINE SPEED. AT IDLE THE LIGHTS WILL DIM. AS THE ENGINE IS SPEEDED UP, THE LIGHTS WILL BECOME THEIR BRIGHTEST.

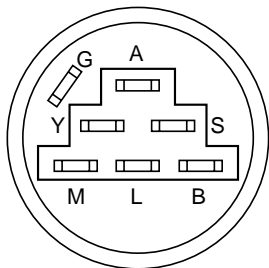

IGNITION SWITCH

POSITION	CIRCUIT	"MAKE"
OFF	G + M + L	NONE
RUN/LIGHT	B + L	A + Y
RUN	B + L	NONE
START	B + L + S	NONE

TRACTOR CONNECTOR

IGNITION SWITCH "M" FOR ENGINE SHORTING (BLACK WIRE)

BATTERY CHARGING (RED WIRE)

OIL SENTRY OPTION (YELLOW WIRE TO LIGHT PKG.)

SWITCHED +12V (BLUE WIRE)

ENGINE CONNECTOR

REGULATOR (PURPLE WIRE, RED WIRE)

ENGINE SHORTING (WHITE WIRE)

CARBURETOR SOLENOID (RED WIRE, BLUE WIRE)

OIL SENTRY (GREEN WIRE)

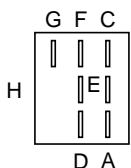

PTO SWITCH

POSITION	CIRCUIT
OFF	C + G, B + H
ON	C + F, B + E, A + D

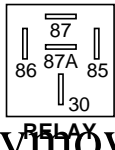

RELAY

NON-REMOVABLE CONNECTIONS

REMOVABLE CONNECTIONS

INDICATOR LIGHTS

- ① DEPRESS FOOT PEDAL
- ② DISENGAGE ATTACHMENT
- ③ CHECK OIL
- ④ LOW FUEL

TRACTOR - MODEL NO. GT200 (954140011A)

ELECTRICAL

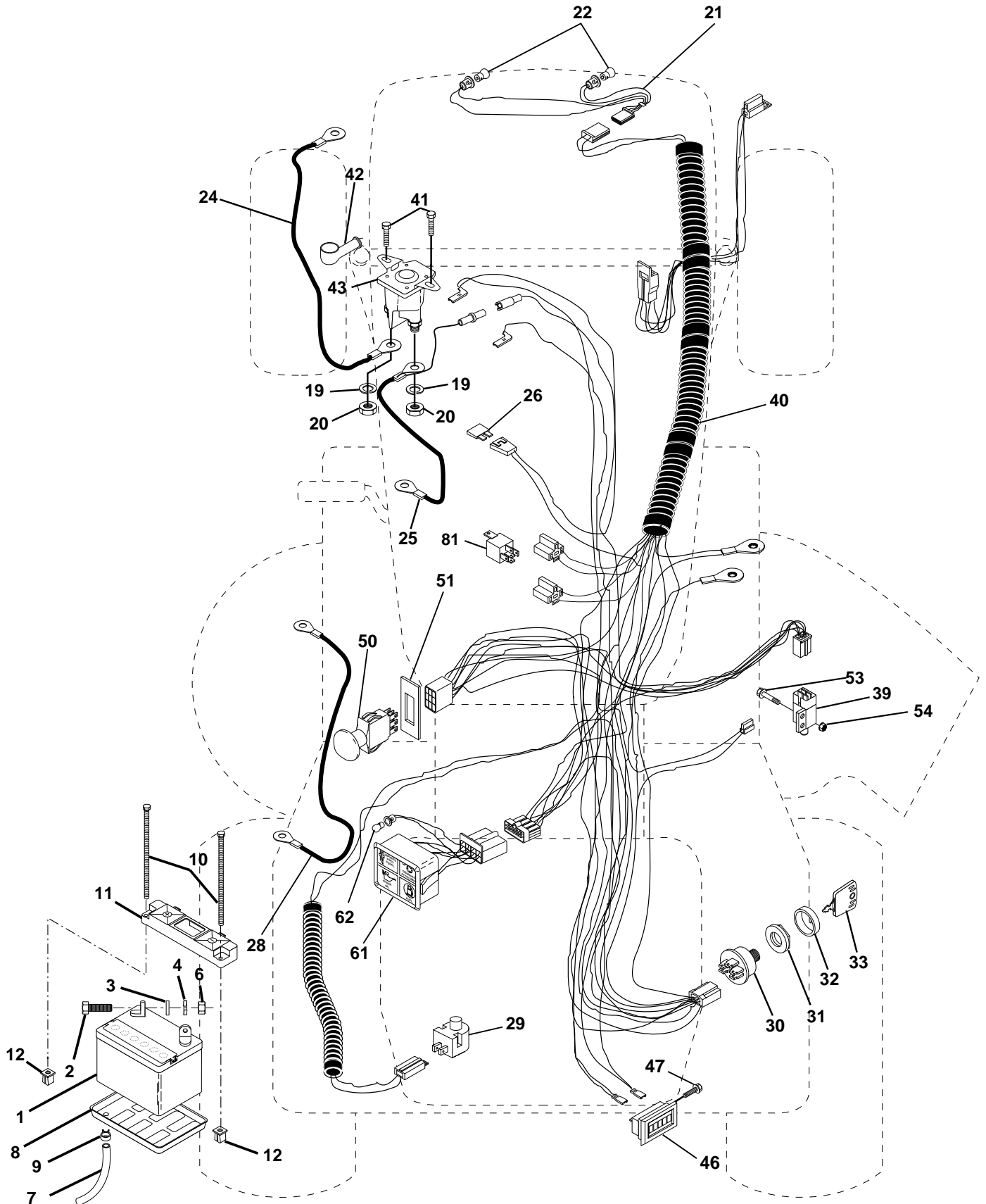

TRACTOR - MODEL NO. GT200 (954140011A)

ELECTRICAL

KEY NO.	PART NO.	DESCRIPTION
1	532 14 61-41	Battery
2	874 76 04-12	Bolt Hex Head 1/4-20 x 3/4
3	810 04 04-00	Washer, Lock 1/4
4	819 09 10-16	Washer 9/32 x 5/8 x 16 Ga
6	873 22 04-00	Nut Fin Hex 1/4-20
7	532 00 76-97	Tube Plastic
8	532 12 48-86	Tray, Battery
9	532 10 95-96	Clamp, Hose
10	532 14 52-11	Bolt, Btr Frt 1/4-20 x 7-1/2 Zinc
11	532 15 01-09	Holddown Battery Front Mount
12	532 14 57-69	Nut Push Nylon 1/4" Battery Frt.
19	810 09 04-00	Washer, Lock 1/4
20	873 35 04-00	Nut, Jam Hex 1/4-20
21	532 13 68-50	Harness Socket Light w/4152J
22	532 00 41-52	Bulb Light
24	532 00 40-14	Cable, Starter
25	532 14 66-86	Cable, Battery
26	532 10 88-24	Fuse
28	532 00 64-08	Cable, Ground
29	532 12 13-05	Switch, Plunger
30	532 14 03-01	Switch, Ign
31	532 12 42-11	Nut, Ignition Switch
32	532 14 12-26	Cover Switch Key
33	532 12 21-47	Key
39	532 10 95-53	Intlk Switch
40	532 15 61-60	Harness Ign.
41	817 72 04-08	Screw 1/4-20 x 1/2
42	532 13 15-63	Cover, Terminal Red
43	532 14 56-73	Solenoid
46	532 11 09-40	Meter Hour
47	817 01 10-08	Screw #10-24 x 1/2
50	532 15 49-59	Switch, PTO
51	532 14 04-05	Ring Retainer PTO
53	871 03 10-08	Screw Hex Washer Hd #10-32 x 1
54	873 95 10-00	Nut Keps #10-32
61	532 13 81-01	Light Pkg Asm
62	532 11 01-43	Bulb, Light Pkg.
81	532 10 97-48	Relay Asm.

NOTE: All component dimensions given in U.S. inches
1 inch = 25.4 mm

TRACTOR - MODEL NO. GT200 (954140011A)

CHASSIS AND ENCLOSURES

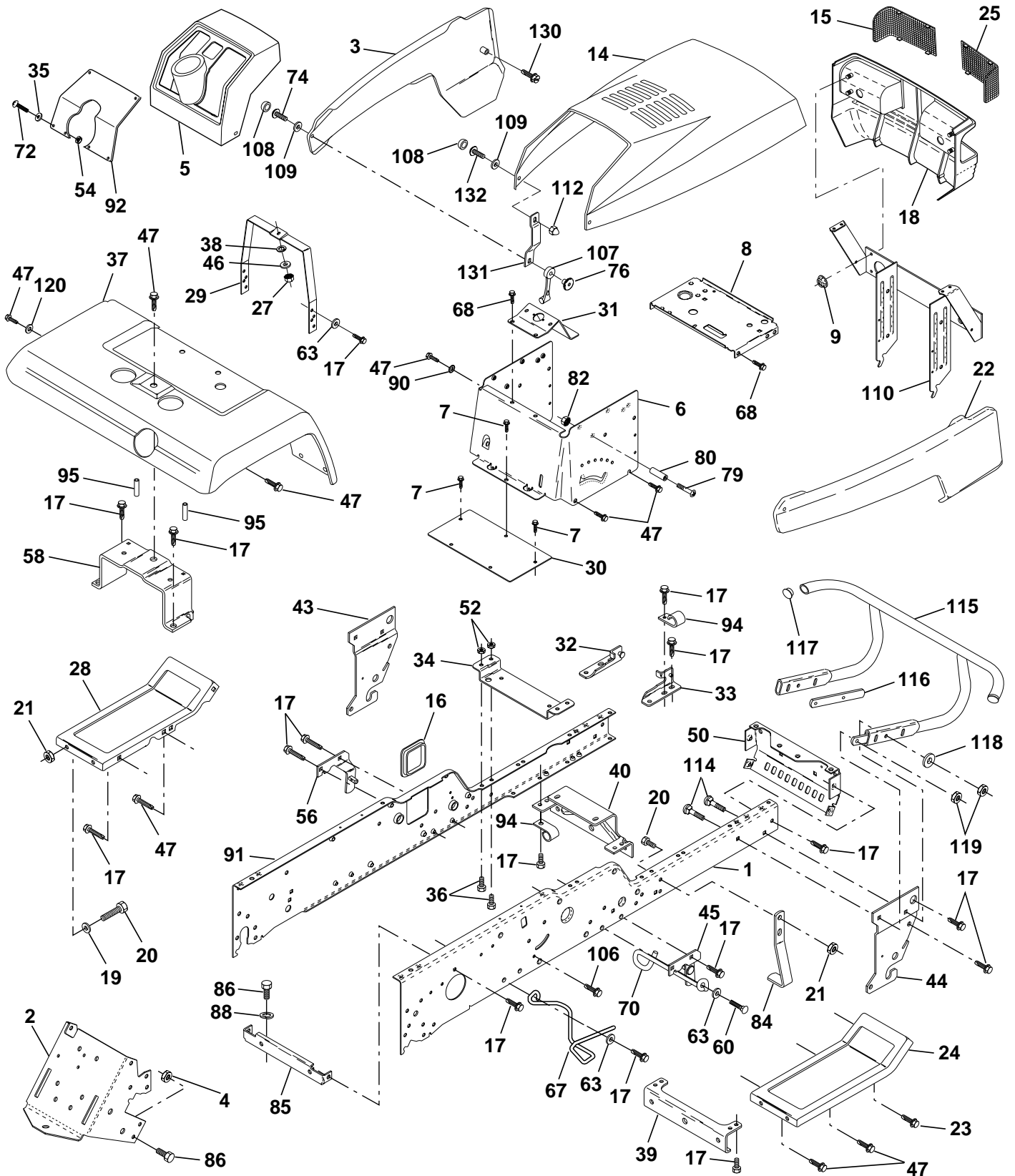

TRACTOR - MODEL NO. GT200 (954140011A)

CHASSIS AND ENCLOSURES

KEY NO.	PART NO.	DESCRIPTION	KEY NO.	PART NO.	DESCRIPTION
1	532 15 02-53	Rail, Frame RH	54	873 51 05-00	Nut 5/16-18
2	532 14 05-06	Drawbar, Gt	56	532 15 49-14	Bracket Asm., Susp Chassis Lh
3	532 15 04-78	Panel Asm., Side LH	58	532 13 71-13	Bracket Asm., Fender
4	873 80 07-00	Nut, Lock Hex 7/16 Unc	60	817 49 06-20	Screw Thdrol 3/8-16 x 1-1/4
5	532 14 04-52	Dash, Plastic Black	63	819 13 16-14	Washer 13/32 x 1 x 14 Ga.
6	532 15 02-73	Dash 1-PCS, Lower	67	532 14 07-37	Guide Belt Trans VGT
7	817 72 04-08	Screw, Thd Cut 1/4-20 x 1/2	68	817 49 05-08	Screw, Thdrol 5/16-18 x 1/2
8	532 14 51-66	Support, Battery	70	532 13 71-59	Guide, Belt Mid Span
9	532 10 80-67	Nut Pal	72	874 18 05-12	Screw, Mach Trhd 5/16-18 x 3/4
14	532 15 04-77	Hood Asm., Pnt	74	874 19 10-08	Screw, Machine #10-24
15	532 15 70-68	Lens, Headlight LH	76	532 12 50-04	Nut, Weld #10-24
16	532 12 17-94	Cover, Access	79	874 98 10-20	Screw, Machine #10-24 x 1/4
17	817 49 06-12	Screw, Thdrol 3/8-16 x 3/4	80	532 00 72-06	Spacer, Split
18	532 15 72-36	Grille	82	873 73 10-00	Nut #10-24
19	819 13 13-12	Washer 13/32 x 13/16 x 12 Ga.	84	532 14 29-92	Stop, Over Center 44" 20/23" T. 94
20	874 76 06-16	Bolt, Fin Hex 3/8-16 x 1	85	532 14 49-11	Bracket Support Pnt Trans VGT
21	873 68 06-00	Nut, Crownlock 3/8-16 Unc	86	874 76 07-16	Bolt, Fin Hex 7/16-14 Unc x 1
22	532 15 04-79	Panel Asm., Side RH	88	810 04 07-00	Washer Lock Hvy Hlcl Spr 7/16
23	817 49 06-16	Screw Thdrol. 3/8-16 x 1 Ty-TT	90	811 05 06-00	Washer, Lock External Tooth 3/8
24	532 14 72-02	Footrest, RH	91	532 15 08-51	Rail, Frame Lh
25	532 15 70-69	Lens Headlight RH	92	532 15 72-21	Plate, Silkscreen Dash
27	873 22 04-00	Nut Fin Hex 1/4-20	94	532 10 02-07	Clip, Fuel Line
28	532 14 72-03	Footrest, LH	95	532 10 55-31	Push Nut, Nylon
29	532 14 52-05	Bracket, Support Dash	106	532 13 87-76	Screw Thdrol. Hex Hd Zinc Mur
30	532 14 84-11	Saddle	107	532 10 98-08	Latch, Chute Blk
31	532 14 51-83	Brace, Support Steering	108	532 11 03-56	Cap, Snap Black
32	532 14 13-15	Bracket Asm., Frame Pivot Lh	109	532 11 03-57	Cap, Washer Snap
33	532 14 13-14	Bracket Asm., Frame Pivot Rh	110	532 15 02-00	Pivot Asm. Grille/Hood Husq. VGT
34	532 14 21-31	Bracket, Engine Support Rear	112	532 06 08-67	Nut, Acorn, Hex #10-24
35	819 11 11-16	Washer 11/32 x 11/16 x 16 Ga.	114	872 14 06-10	Bolt, Carriage 3/8-16 x 1-1/4
36	874 78 05-12	Bolt, Fin Hex 5/16-18 x 3/4	115	532 15 03-00	Bumper Asm.
37	532 12 49-27	Fender, Pnt.	116	532 14 14-61	Bracket Extension Bumper
38	810 04 04-00	Washer, Lock 1/4	117	532 14 36-79	Plug Plastic
39	532 13 69-61	Bracket, Axle Front	118	819 13 13-16	Washer 13/32 x 13/16 x 16 Ga.
40	532 14 21-32	Bracket, Support Axle/Engine	119	873 68 06-00	Nut Crownlock 3/8-16 UNC
43	532 13 69-39	Bracket, Spnsn Front Lh	120	819 13 16-16	Washer 13/32 x 1 x 16 Ga.
44	532 13 69-40	Bracket, Spnsn Front Rh	130	817 52 13-12	Screw, SLTD Hex Hd. W/PI Washer
45	532 15 49-13	Bracket Asm., Susp Chassis Rh	131	532 15 01-95	Bracket Support Hood/Panel YP
46	819 09 12-16	Washer 9/32 x 3/4 x 16 Ga.	132	874 29 10-06	Screw Truss Hd #10-24 x 3/8
47	817 49 06-08	Screw Thdrol 3/8-16 x 1/2	--	532 12 50-85	Plug, Hole
50	532 15 27-28	Bracket, Chassis Front			
52	873 80 05-00	Locknut, Hex W/Ins 5/16-18 Unc			

NOTE: All component dimensions given in U.S. inches
1 inch = 25.4 mm

TRACTOR - MODEL NO. GT200 (954140011A)

GROUND DRIVE

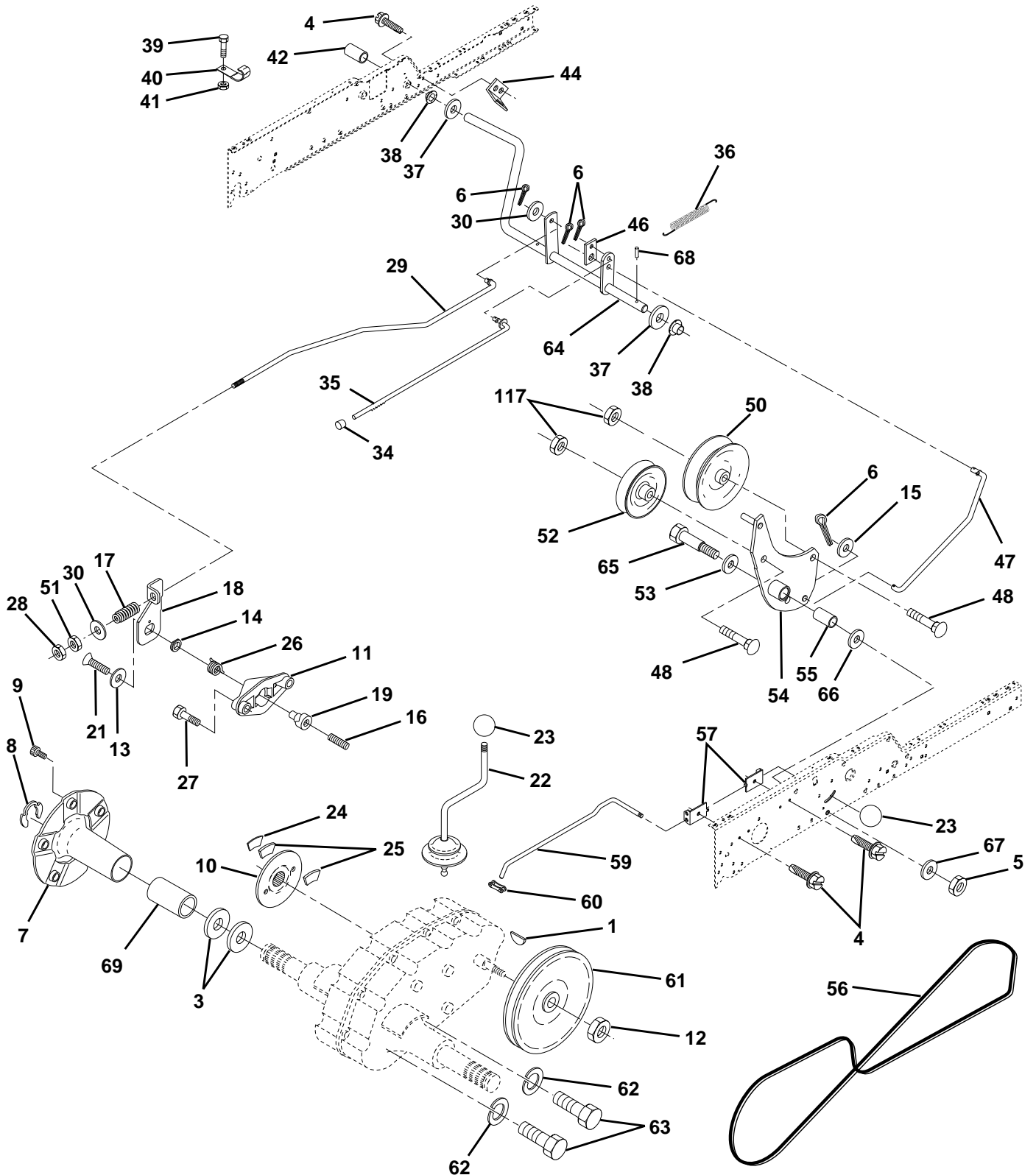

TRACTOR - MODEL NO. GT200 (954140011A)

GROUND DRIVE

KEY NO.	PART NO.	DESCRIPTION	KEY NO.	PART NO.	DESCRIPTION
1	532 12 47-08	Key Woodruff	38	532 15 00-35	Nyliner
3	532 00 75-63	Washer Thrust Axle Harden	39	874 32 10-16	Screw Fin #10-24 x 1
4	817 49 05-08	Screw Thdrol 5/16-18 x 1/2 TYT	40	532 00 53-04	Actuator Interlock Switch
5	873 68 06-00	Nut Crownlock 3/8-16	41	873 63 10-00	Nut Lock #10-24
6	876 02 04-12	Pin Cotter 1/8 x 3/4	42	532 12 35-33	Cover Pedal
7	532 14 91-76	Wheel Hub Asm.	43	874 76 04-12	Bolt Hex Head 1/4-20 x 3/4
8	812 00 00-34	Ring Klip	44	532 10 46-01	Bracket Interlock
9	532 14 00-80	Bolt Hub	45	873 80 04-00	Nut Lock W/Insert 1/4-20
10	532 14 25-09	Disc Brake	46	532 14 51-70	Retainer Spring
11	532 13 69-27	Yoke Brake Disc	47	532 13 82-28	Clutch Rod
12	532 00 92-04	Locknut 1/2-20	48	872 11 06-14	Bolt Carriage 3/8-16 x 1-3/4 Gr 5
13	532 13 94-19	Washer Special	49	819 13 14-13	Washer 13/32 x 7/8 x 13 Ga
14	532 13 89-01	Bushing	50	532 13 14-94	Pulley Idler Flat
15	819 13 13-16	Washer 13/32 x 13/16 x 16 Ga	51	873 80 06-00	Nut Lock Hex 3/8-16
16	532 14 30-12	Set Screw 1/4-28 x 3/4	52	532 13 91-23	Pulley Idler Grooved
17	532 12 69-09	Spring	53	532 00 02-07	Washer Hardtened
18	532 13 71-04	Lever Brake	54	532 13 83-90	Clutch Arm Asm
19	532 13 69-26	Cam Brake Disc	55	532 10 57-06	Bearing, Idler
21	823 26 04-12	Screw Flat Head 1/4-28 x 3/4	56	532 13 71-53	V-Belt
22	532 12 48-63	Gearshift Lever Assembly	57	532 14 17-56	Bracket Shift Rod Hi-Lo
23	532 12 14-66	Knob	59	532 12 22-53	Shift RodHi-Lo
24	532 13 69-25	Support Puck Brake	60	532 12 22-68	Spring Clip Connecting Link
25	532 13 69-23	Puck Brake Top	61	532 13 75-24	Pulley Transaxle
26	532 13 75-52	Spring Return	62	810 04 07-00	Washer Lock 7/16
27	817 49 05-28	Screw Hex Wsh Thd 5/16-18 x 1-3/4	63	874 76 07-20	Bolt Fin Hex 7/16-14 x 1-1/4
28	873 35 06-00	Nut Hex Jam 3/8-16	64	532 15 47-52	Shaft Clutch/Brake Pedal
29	532 13 72-13	Brake Rod	65	532 06 76-09	Bolt Shoulder
30	819 13 16-16	Washer 13/32 x 1 x 16 Ga	66	532 14 02-96	Washer Hardened
34	532 07 16-73	Cap Plunger	67	819 13 13-12	Washer 13/32 x 13/16 x 12 Ga.
35	532 13 76-48	Rod Parking Brake	68	532 00 51-42	Pin Roll
36	532 14 94-12	Spring Drive Ground	69	532 13 63-27	Hub Cover
37	532 12 17-49	Washer 25/32 x 1-1/4 x 16 Ga			

NOTE: All component dimensions given in U.S. inches
 1 inch = 25.4 mm

TRACTOR - MODEL NO. GT200 (954140011A)

STEERING ASSEMBLY

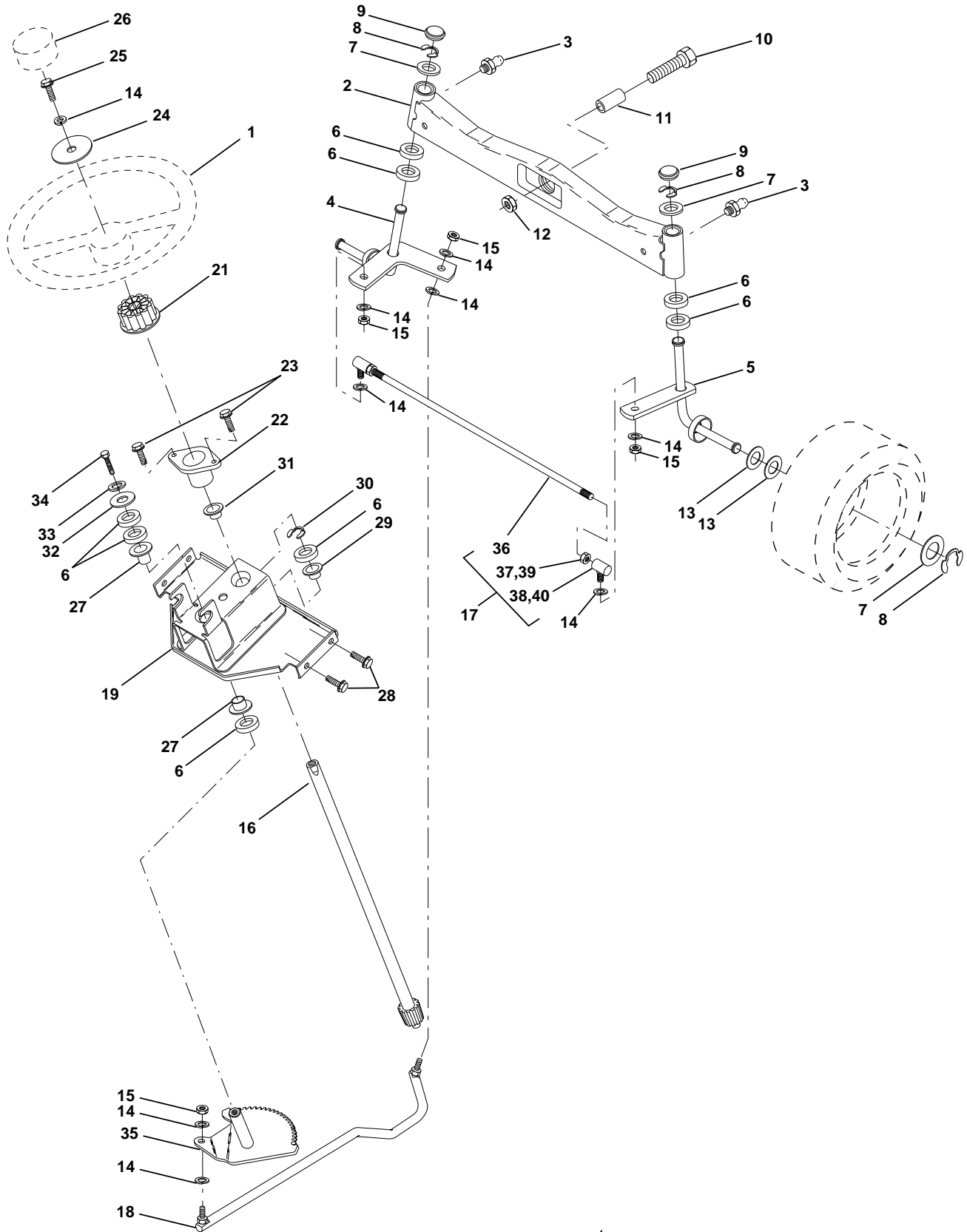

TRACTOR - MODEL NO. GT200 (954140011A)

STEERING ASSEMBLY

KEY NO.	PART NO.	DESCRIPTION
1	532 12 44-15	Wheel, Steering
2	532 13 70-94	Axle Asm., Front
3	532 12 48-36	Fitting, Grease
4	532 13 69-60	Spindle Asm, LH
5	532 13 69-59	Spindle Asm., RH
6	532 12 49-31	Bearing, Race Thrust Harden
7	532 12 17-48	Washer 25/32 x 1-5/8 x 16 Ga.
8	812 00 00-29	Ring, Klip #T5304-75
9	532 12 12-32	Cap, Spindle
10	874 78 10-44	Bolt, Fin Hex 5/8-11 x 2-3/4
11	532 13 65-18	Spacer, Brg. Axle Front
12	873 90 10-00	Nut, Lock Flange 5/8-11 Unc
13	532 12 17-49	Washer 25/32 x 1-1/4 x 16 Ga.
14	810 04 06-00	Washer, Lock Hvy Hlcl Spr 3/8
15	532 12 47-01	Nut, Lock Center 3/8-24 Unf
16	532 14 51-03	Shaft Asm., Steering
17	532 13 73-47	Rod Asm., Tie Ball J Ball Vgt (Inc. Key No. 36-40)
18	532 13 71-55	Draglink, Ball Joint Solid Vgt
19	532 14 66-11	Support Asm., Steering Vgt
21	532 10 07-11	Adapter, Wheel Steering
22	532 15 51-05	Bushing, Strg. Blk
23	532 15 29-27	Screw
24	819 13 38-08	Washer 13/32 x 2-3/8 x 8 Ga.
25	874 78 06-16	Bolt, Fin Hex 3/8-16 x 1 Gr. 5
26	532 12 44-16	Cap, Wheel Steering
27	532 12 49-37	Bearing, Col. Strg.
28	817 49 06-12	Screw Thdrol 3/8-16 x 3/4
29	532 10 42-39	Bearing, Flange
30	812 00 00-34	Ring, Klip Truarc #5304-75
31	532 13 81-36	Bushing, Nyliner Snap
32	819 11 16-10	Washer 11/32 x 1 x 10 Ga.
33	810 04 05-00	Washer, Lock Hvy Hlcl Spr 5/16
34	874 76 05-12	Bolt, Hex Hd 5/16-18 x 3/4
35	532 13 80-59	Gear, Sector Steering
36	532 13 71-56	Tie Rod
37	873 36 06-00	Jam Nut RH Thread
38	532 10 98-50	Joint Asm. Ball RH Thread
39	873 70 06-00	Jam Nut LH Thread
40	532 10 98-51	Joint Asm. Ball LH Thread

NOTE: All component dimensions given in U.S. inches
 1 inch = 25.4 mm

TRACTOR - MODEL NO. GT200 (954140011A)

ENGINE

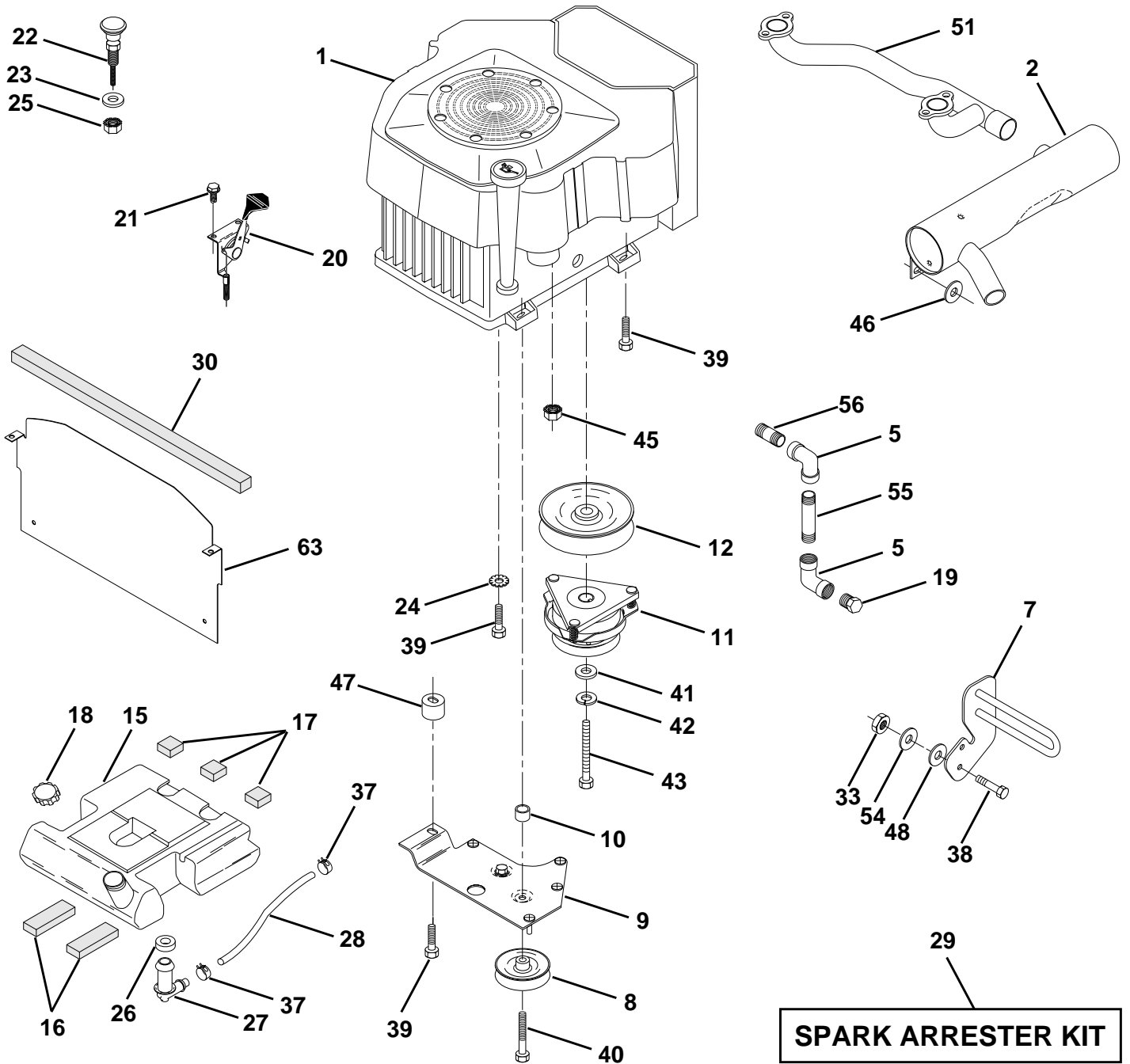

TRACTOR - MODEL NO. GT200 (954140011A)

ENGINE

KEY NO.	PART NO.	DESCRIPTION
1	-----	Engine Kohler, Model No. CV20S
2	532 14 46-36	Muffler VGT Cylinder
5	813 20 03-00	Elbow STD 90 Degree 3/8-18 NPT
7	532 15 13-96	Muffler Assembly Guard
8	532 12 13-61	Pulley V-Idler
9	532 15 08-28	Keeper Asm. Belt Engine VGT 96
10	532 10 54-32	Bushing
11	532 14 09-23	Clutch Electric
12	532 14 39-96	Pulley Engine VGT Elect Clutch
15	532 15 13-46	Tank Fuel Rear 3.50 YT/GT 96
16	532 10 92-27	Pad Spacer
17	532 10 60-82	Pad Spacer
18	532 14 05-27	Cap Asm Fuel W/Sym Vented
19	813 29 03-00	Plug Oil Drain (Order From Engine Manufacturer)
20	532 13 27-47	Control Throttle
21	817 72 04-10	Screw Hex Thd Cut 1/4-20 X 5/8
22	532 13 27-81	Control Choke
23	819 13 13-16	Washer 13/32 X 13/16 x 16 Ga
24	811 05 06-00	Washer Ext Tooth 3/8
25	873 92 06-00	Nut Keps 3/8 - 24 UNF
26	532 12 49-52	Bushing
27	532 13 92-77	Stem Tank Fuel
28	532 12 47-03	Fuel Line
29	532 13 29-20	Spark Arrester Kit
30	532 10 50-37	Strip Foam 18"
33	873 80 06-00	Nut, Hex W/Ins. 3/8-16 UNC
37	532 12 34-87	Clamp Hose
38	874 78 06-24	Bolt, Fin Hex 3/8-16 UNC x 1-1/2
39	817 49 06-36	Screw TT 3/8-16 x 2-1/4 UNC
40	817 49 06-64	Screw TT 3/8-16 x 4 UNC
41	532 12 61-97	Washer 1-1/2 OD X 15/32 ID X .250
42	810 04 07-00	Washer Lock 7/16
43	532 15 02-80	Bolt Hex 7/16-20 X 4-1/4 Ga 5
45	532 12 88-61	Nut Flange 1/4-20 Starter Nut
46	819 13 16-16	Washer 13/32 x 1 x 16 Ga.
47	532 14 20-40	Spacer Engine
48	819 13 20-07	Washer 13/32 x 1-1/4 x 7 Ga.
51	532 14 07-87	Pipe Crossover
54	819 13 14-14	Washer Flat 13/32 x 7/8 x 14 Ga.
55	813 09 03-36	Nipple, Pipe 3/8 NPT x 4-1/2
56	813 09 03-08	Nipple, Pipe 3/8 NPT x 1.00
63	532 14 55-49	Shield, Heat VGT YP/Husq.

NOTE: All component dimensions given in U.S. inches
 1 inch = 25.4 mm

TRACTOR - MODEL NO. GT200 (954140011A)

SEAT ASSEMBLY

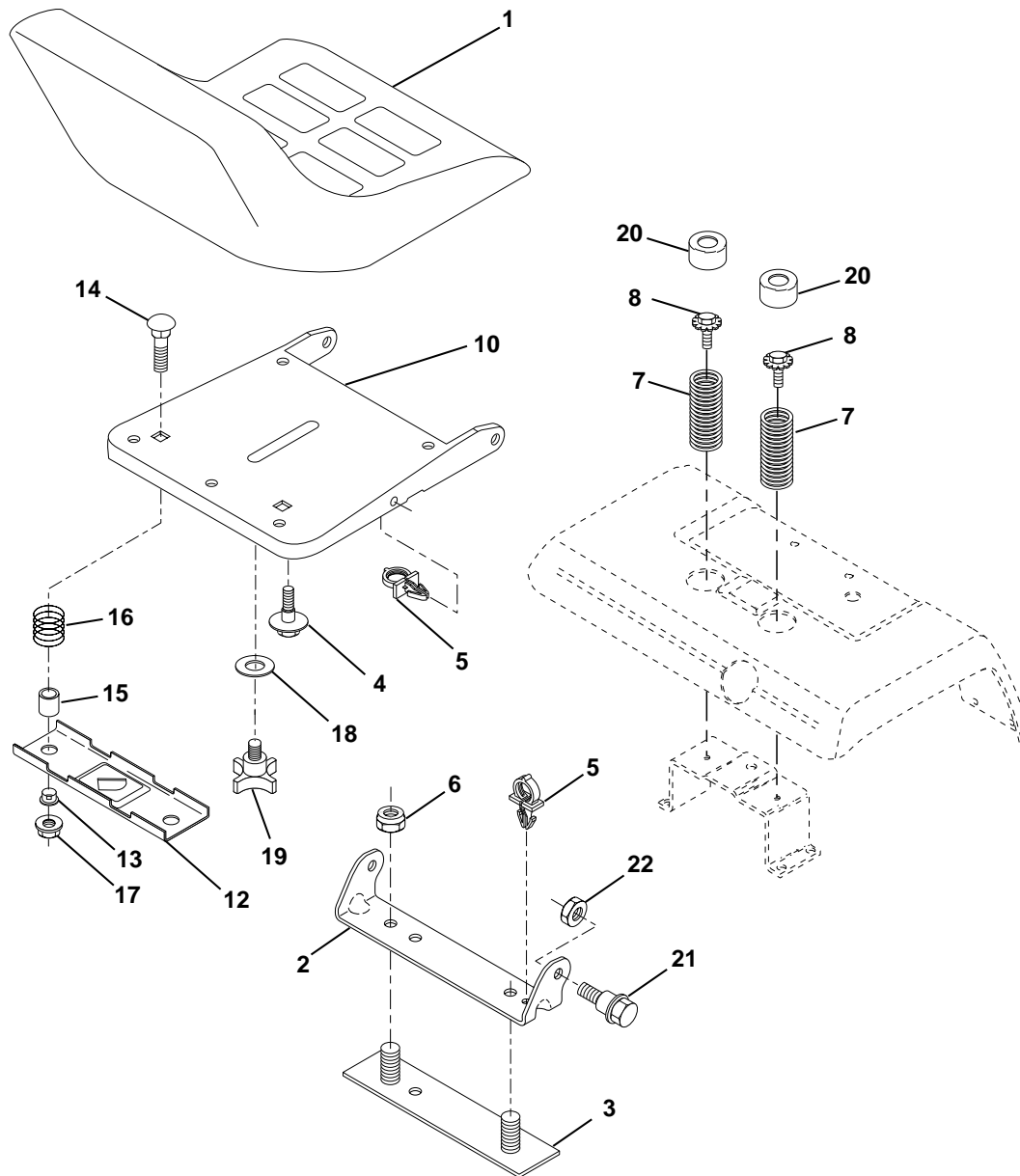

KEY NO.	PART NO.	DESCRIPTION
1	532 14 15-25	Seat
2	532 14 05-51	Bracket, Pivot Seat
3	532 14 06-75	Strap, Fender
4	532 12 70-18	Bolt, Shoulder 5/16-18 X .62
5	532 14 50-06	Clip, Push In Hinged
6	873 80 06-00	Nut, Lock Hex W/Ins. 3/8-16 Unc
7	532 12 41-81	Spring, Seat Cprsn
8	532 15 01-76	Bolt 5/16-18 UNC x 3/4 w/Sems
10	532 15 59-25	Pan, Seat
12	532 12 12-46	Bracket, Mounting Switch
13	532 12 12-48	Bushing, Snap
14	872 05 04-11	Bolt, Carriage 1/4-20 X 1-3/8

KEY NO.	PART NO.	DESCRIPTION
15	532 12 12-49	Spacer, Split
16	532 12 37-40	Spring, Cprsn
17	532 12 39-76	Nut, Lock 1/4 Lge Flg Gr. 5
18	819 17 19-12	Washer 17/32 X 1-3/16 X 12 Ga.
19	532 12 00-68	Knob, Seat 1/2-13 Unc
20	532 12 42-38	Cap, Spring Seat
21	532 15 32-36	Bolt, Shoulder 5/16-18 Unc-2A
22	873 68 05-00	Nut, Crownlock 5/16-18 Unc

NOTE: All component dimensions given in U.S. inches
1 inch = 25.4 mm

TRACTOR - MODEL NO. GT200 (954140011A)

DECALS

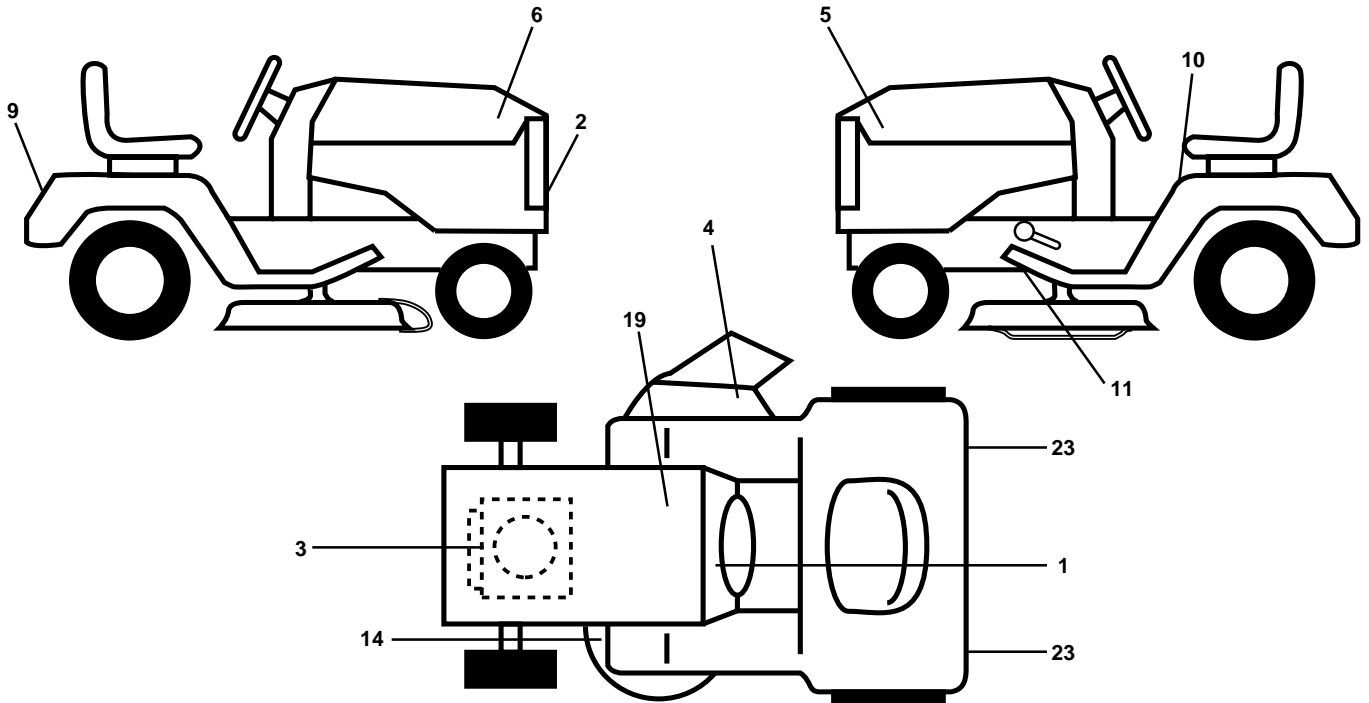

KEY NO.	PART NO.	DESCRIPTION
1	532 15 71-06	Decal, Operating Instruction
2	532 15 06-16	Decal, Grille Husqvarna
3	532 15 37-00	Decal, Kohler
4	532 13 72-59	Decal, Warning Mult-Lang.
5	532 15 06-41	Decal, Hood LH GT200
6	532 15 06-40	Decal, Hood RH GT200
9	532 15 06-17	Decal, Fender
10	532 15 71-40	Decal, Danger
11	532 10 18-92	Decal, Clutch/Brake
14	532 13 93-46	Decal, V-Belt Schematic

KEY NO.	PART NO.	DESCRIPTION
19	532 14 64-51	Decal, Battery
23	532 10 62-02	Reflector, Taillight
--	532 13 83-11	Decal, Handle Lft Height Adjust (Lift Handle)
--	532 14 52-46	Pad Ftrest Rbr Sq Generic 95
--	532 14 52-47	Fastener Pop-In Footrest (8 per)
--	532 15 71-26	Manual, Owner's (English)
--	532 15 71-28	Manual, Owner's (French)

Accessories not included with tractor:

- SH10 Sleeve Hitch
- TA128 Tire Chains
- TS20 8HP Tiller
- TA321 #55 Wheel Weights
- TR72 Dozer Blade
- TR30 10" Plow

WHEELS & TIRES

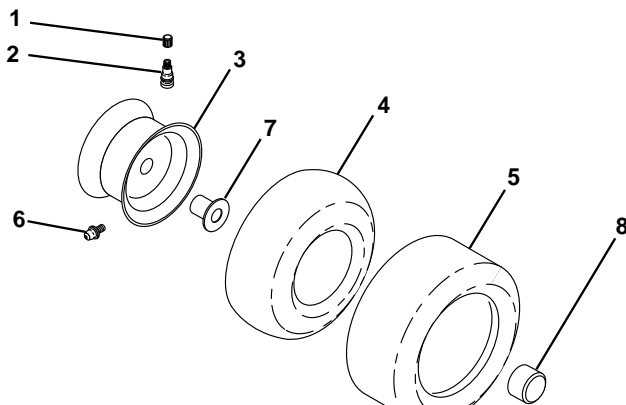

KEY NO.	PART NO.	DESCRIPTION
1	532 05 91-92	Cap, Valve, Tire
2	532 06 51-39	Stem, Valve
3	532 14 45-09	Rim Assembly, Front
	532 14 45-10	Rim Assembly, Rear
4	532 00 81-34	Tube, Front (Service Item Only)
	532 00 71-54	Tube, Rear (Service Item Only)
5	532 10 62-30	Tire, Front
	532 10 55-88	Tire, Rear
6	532 12 48-60	Fitting, Grease
7	532 12 49-59	Bearing, Flange (Front Wheel Only)
8	532 10 47-57	Cap, Hub, Axle Blk.
--	532 14 43-34	Sealant, Tire (10 oz. Tube)

NOTE: All component dimensions given in U.S. inches
 1 inch = 25.4 mm

TRACTOR - MODEL NO. GT200 (954140011A)

LIFT ASSEMBLY

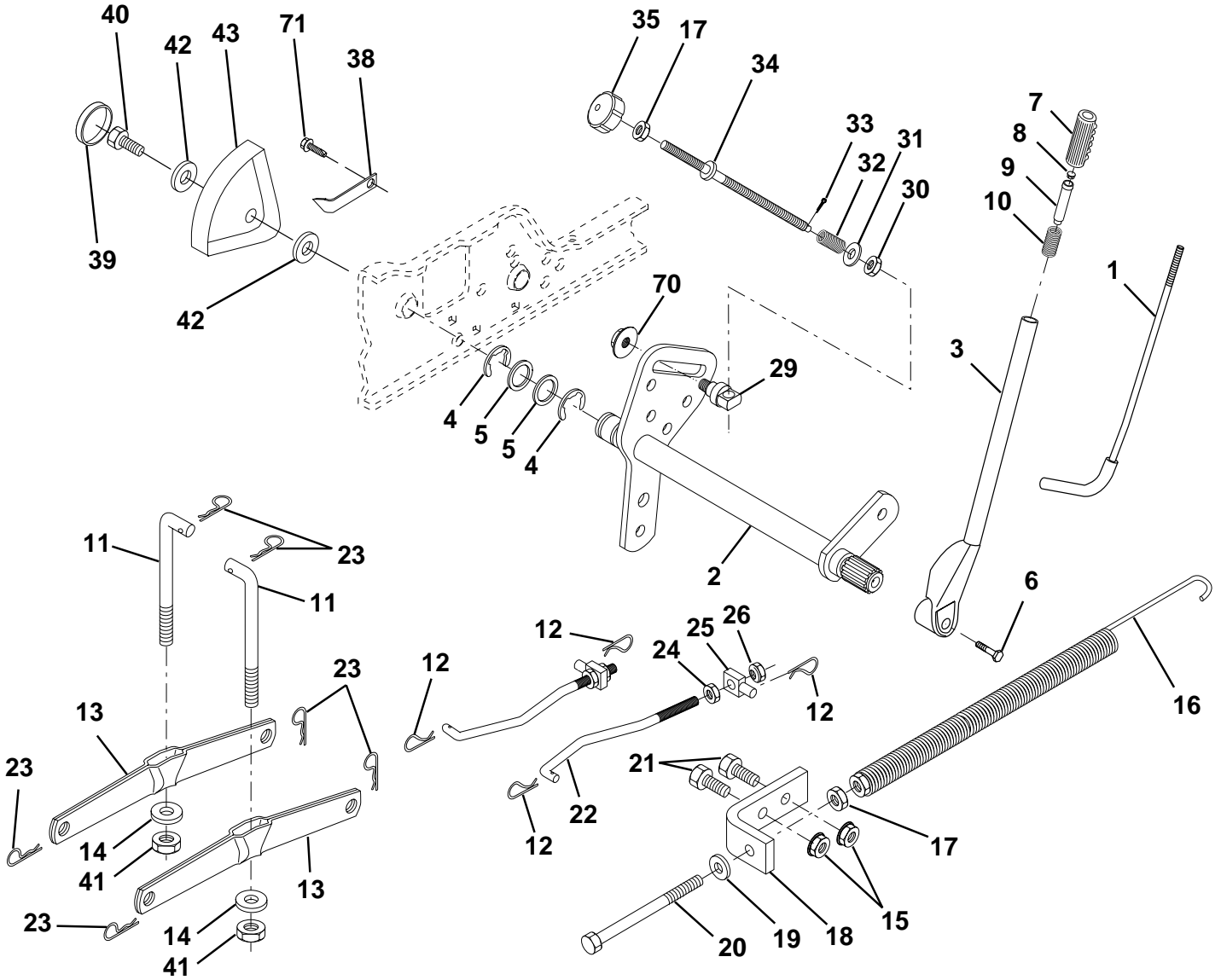

TRACTOR - MODEL NO. GT200 (954140011A)

LIFT ASSEMBLY

KEY NO.	PART NO.	DESCRIPTION
1	532 12 10-06	Rod Asm., Lever
2	532 15 43-89	Shaft Asm., Lift Vgt
3	532 12 10-02	Lever Asm., Lift Rh
4	812 00 00-22	E-Ring Truarc #5133-87
5	819 29 20-16	Washer 29/32 x 1-1/4 x 16 Ga.
6	874 78 06-24	Bolt, Fin Hex 3/8-16 x 1-1/2
7	532 12 56-31	Grip, Handle Fluted
8	532 12 45-26	Button, Plunger
9	532 12 23-64	Plunger, Lever Lift
10	532 12 48-74	Spring 2-1/8"
11	532 14 67-04	Link Lift
12	532 12 46-60	Retainer, Spring
13	532 13 98-68	Arm, Suspension Vgt
14	532 14 03-02	Bearing
15	873 68 06-00	Nut, Crownlock 3/8-16 Unc
16	532 12 46-87	Spring Asm., Assist Lift
17	873 35 06-00	Nut, Hex Jam 3/8-16 Unc
18	532 14 33-63	Bracket, Spring Assist
19	819 13 13-16	Washer 13/32 x 13/16 x 16 Ga.
20	532 00 53-28	Bolt, Adjust Spring Assist
21	874 76 06-16	Bolt, Fin Hex 3/8-16 x 1
22	532 12 72-18	Link, Front
23	532 12 46-70	Retainer, Spring
24	873 35 08-00	Nut, Jam Hex 1/2-13 Unc
25	532 13 01-71	Trunnion
26	873 80 08-00	Nut, Lock W/Wsh 1/2-13 Unc
29	532 15 02-33	Trunnion, Infin Height
30	532 11 08-07	Nut, Special
31	819 13 10-16	Washer 13/32 x 5/8 x 16 Ga.
32	532 13 71-50	Spring, Compression Inf Hgt
33	876 02 03-08	Pin, Cotter 3/32 x 1/2
34	532 13 71-67	Rod, Adj Lift
35	532 13 80-57	Knob, Inf 3/8-16 Unc
36	817 49 06-12	Screw, Thdrol 3/8-16 x 3/4
37	532 12 05-29	Washer, Nylon
38	532 13 83-46	Pointer, Pnt Height Indicator
39	532 12 39-35	Plug, Hole
40	817 49 05-12	Screw Thdrol 5/16-18 x 3/4
41	873 54 06-00	Nut, Crownlock 3/8-24
42	819 11 24-10	Washer 11/32 x 1-1/2 x 10 Ga.
43	532 12 39-34	Scale, Indicator Height
70	532 14 52-12	Nut Hexflange Lock

NOTE: All component dimensions given in U.S. inches
1 inch = 25.4 mm

TRACTOR - MODEL NO. GT200 (954140011A)

MOWER DECK

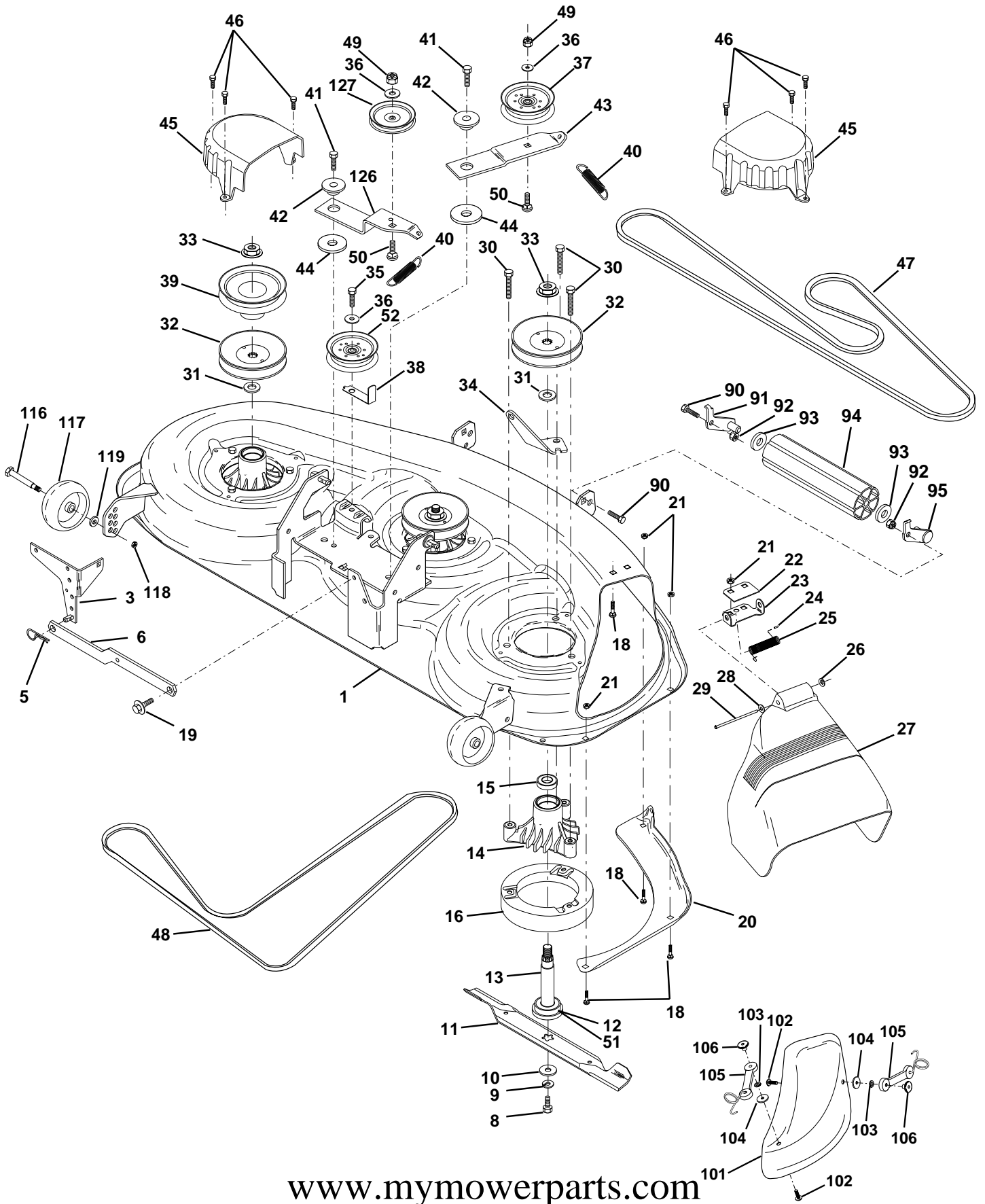

TRACTOR - MODEL NO. GT200 (954140011A)

MOWER DECK

KEY NO.	PART NO.	DESCRIPTION	KEY NO.	PART NO.	DESCRIPTION
1	532 15 31-25	Deck Asm., Mower 46"	42	532 12 20-52	Spacer, Retainer
3	532 13 84-57	Bracket Asm., Sway Bar	43	532 14 49-49	Arm, Idler Secondary
5	532 12 46-70	Retainer Spring	44	532 13 39-43	Washer, Hardened
6	532 13 08-32	Arm, Suspension, Rear (Sway Bar)	45	532 14 50-59	Cover, Mandrel Deck
8	532 85 08-57	Bolt, Patched 3/8-24 x 1-1/4 Gr. 8	46	532 13 77-29	Screw, Thdroll. 1/4-20 x 5/8
9	810 03 06-00	Washer, Lock Hvy., Unplated 3/8	47	532 14 49-59	V-Belt, Mower, Secondary
10	532 14 02-96	Washer, Hard Blade, Mower Vented	48	532 14 87-63	V-Belt, Mower, Primary
11	532 15 24-43	Blade, 46" Mulching	49	873 68 06-00	Nut, Crownlock 3/8-16 UNC
12	532 12 98-95	Bearing, Ball, Mandrel #6204	50	872 11 06-12	Bolt, Carriage 3/8-16 x 1-1/2 Gr. 5
13	532 13 75-53	Shaft Asm. w/Lower Bearing (Includes Key No. 12)	51	532 15 33-90	Washer Felt
14	532 13 71-52	Housing, Mandrel	52	532 15 51-91	Pulley Idler Flat 46 PRI drive
15	532 11 04-85	Bearing, Ball, Mandrel	90	874 76 06-16	Bolt Fin Hex 3/8-16 x 1
16	532 14 03-29	Stripper, Mower Round	91	532 13 22-74	Bracket Asm Noseroller LH
18	872 14 05-05	Bolt, Carriage 5/16-18 x 5/8	92	873 80 06-00	Nut Lock Hex W/Ins 3/8-16 UNC
19	532 13 28-27	Bolt, Hex Head, Shoulder 5/16-18	93	819 17 14-16	Washer 17/32 x 7/8 x 16 Ga.
20	532 14 50-55	Baffle, Vortex Mower 46"	94	532 13 22-64	Roller Nose
21	873 68 05-00	Nut, Crownlock 5/16-18 UNC	95	532 13 22-73	Bracket Asm Noseroller RH
22	532 13 47-53	Stiffener, Bracket	101	532 14 55-79	Cover, Mulching
23	532 13 12-67	Bracket, Deflector	102	871 16 10-10	Screw
24	532 10 53-04	Cap, Sleeve	103	810 07 10-00	Washer, Lock #10
25	532 12 37-13	Spring, Torsion, Deflector	104	819 06 12-16	Washer
26	532 11 04-52	Nut, Push	105	532 13 07-58	Latch Asm. Bagger
27	532 14 53-25	Shield, Deflector Mower	106	532 12 50-04	Nut, Weld
28	819 11 10-16	Washer 11/32 x 5/8 x 16 Ga.	116	532 13 76-44	Bolt, Shoulder
29	532 13 14-91	Rod, Hinge	117	532 13 39-57	Gauge Wheel, Wide
30	532 13 87-76	Screw, Hex Head, Thdroll	118	873 93 06-00	Nut, Centerlock 3/8-16 UNC
31	532 12 99-63	Washer, Spacer Mower Vented	119	819 12 14-14	Washer 3/8 x 7/8 x 14 Ga.
32	532 15 35-31	Pulley, Mandrel	126	532 14 49-48	Arm, Idler, Primary Deck 46"
33	532 13 72-66	Nut, Flg. Top Lock Cntr. 9/16	127	532 14 67-63	Pulley, Idler, V-Groove Dim. 4.25
34	532 14 49-45	Anchor, Spring Deck 46"	--	532 14 36-51	Mandrel Asm 44"/50" Service (Includes Key No.s 8-10, 12-15, 31 and 33)
35	817 49 06-28	Screw, Thdroll 3/8-16 x 1-3/4 Tytt	--	532 14 74-01	Deck Complete (Std. Deck-Order separately mulcher plate and gauge wheel components Key Nos. 101-106 and 116-118)
36	819 13 13-16	Washer 13/32 x 13/16 x 16 Ga.			
37	532 13 14-94	Pulley, Idler, Flat			
38	532 13 75-54	Keeper, Belt, Idler			
39	532 14 49-17	Pulley, Idler, Driven			
40	532 13 72-73	Spring, Secondary 44/46/50 Vent			
41	817 49 06-20	Screw, Thdroll 3/8-16 x 1-1/4 Tytt			

NOTE: All component dimensions given in U.S. inches
1 inch = 25.4 mm

TRACTOR - MODEL NO. GT200 (954140011A)

TRANSAXLE

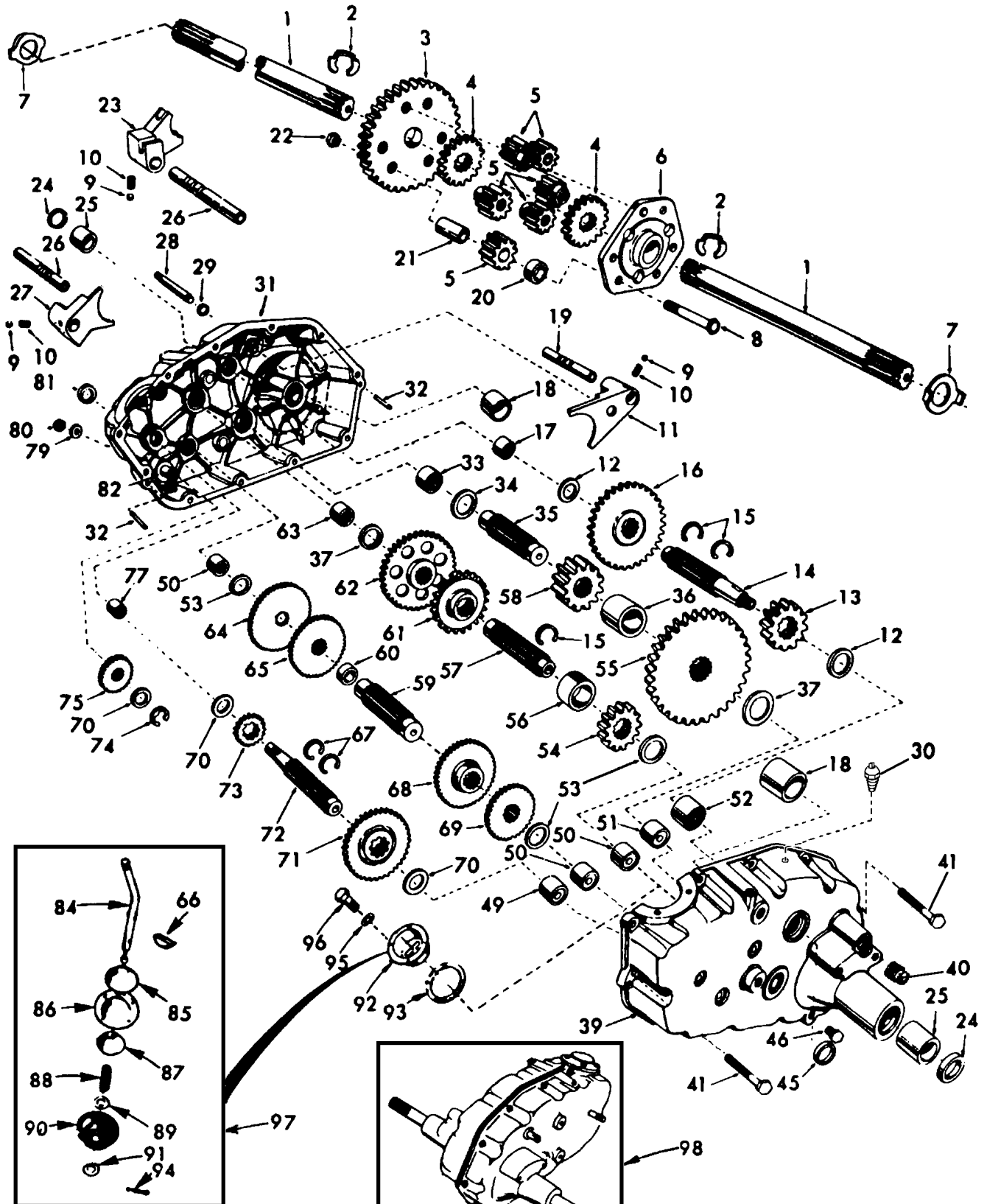

TRACTOR - MODEL NO. GT200 (954140011A)

TRANSAXLE

KEY PART NO.	NO.	DESCRIPTION	KEY PART NO.	NO.	DESCRIPTION
1	532 12 46-62	Axle Shaft	52	532 00 81-19	Needle Bearing
2	812 00 00-34	Retaining Ring	53	532 00 42-20	Thrust Bearing Race
3	532 00 41-99	Final Drive Gear	54	532 00 42-09	3rd Reduction Pinion, Low
4	532 00 42-16	Differential Gear	55	532 12 46-68	4th Reduction Gear
5	532 00 42-15	Differential Pinion	56	532 00 44-42	3rd Reduction Pinion Spacer
6	532 00 42-17	Differential Carrier	57	532 00 41-95	2nd Reduction Gear Shaft
7	532 12 46-74	Axle Thrust Washer	58	532 00 42-14	Final Drive Pinion
8	874 02 06-52	Bolt, Hex Head 3/8-24 x 3-1/4 (1" Thread Length)	59	532 00 41-94	1st Reduction Gear Shaft
9	532 12 46-97	Steel Ball	60	532 00 75-28	1st Reduction Shaft Spacer
10	532 13 72-61	Spring Shift Fork Detent	61	532 12 46-66	3rd Reduction Pinion High
11	532 00 49-85	Shift Fork, High-Low Range	62	532 12 46-65	2nd Reduction Gear
12	532 12 49-31	Thrust Bearing Race	63	532 00 73-98	Needle Bearing
13	532 12 46-67	4th Reduction Pinion	64	532 12 46-64	Low Speed Gear and 2nd Reduction Pinion Cluster
14	532 13 71-25	3rd Reduction Gear Shaft	65	532 00 42-04	Reverse Gear
15	532 12 46-77	Snap Ring, Crescent Type	66	532 00 28-98	Key, Hi-Pro 1/8 x 17/32
16	532 12 46-79	High-Low Range Gears	67	812 00 00-33	Snap Ring, Crescent Type
17	532 00 81-18	Needle Bearing	68	532 00 42-05	Intermediate Speed Gear
18	532 12 47-05	Sintered Iron Bearing	69	532 12 50-99	High Speed Gear
19	532 12 22-38	Shift Fork Shaft, High-Low Range	70	532 00 13-70	Thrust Bearing Race
20	532 00 42-18	Differential Pinion Spacer	71	532 12 46-81	Intermediate and High Speed Cluster Pinions
21	532 12 46-73	Differential Pinion Bushing	72	532 13 91-20	Input Shaft
22	532 12 47-01	Gripco Centerlock Nut 3/8-24	73	532 00 42-01	Low Speed Pinion
23	532 00 62-62	Shift Fork, R.H.	74	812 00 00-08	E-Ring
24	532 12 46-98	Oil Seal	75	532 00 11-53	Reverse Idler Gear
25	532 12 47-09	Sintered Iron Bearing	77	532 00 68-03	Needle Bearing
26	532 13 91-11	Shift Fork Shaft	79	532 00 11-67	Sealing Washer
27	532 00 49-86	Shift Fork, L.H.	80	873 36 07-00	Nut, Hex, Jam 7/16-20
28	532 12 22-54	Shift Shaft, High-Low Range	81	532 12 46-75	Oil Seal
29	532 00 62-69	Oil Seal	82	532 13 69-84	Reverse Idler Shaft
30	532 00 58-55	Pressure Relief Valve	84	532 00 53-84	Gearshift Lever, Bent
31	532 13 95-38	Gearcase, Reverse Idler Shaft and Bearings, R.H. (Includes Key No.'s 17,18, 25, 33, 50, 63, 77 and 82)	85	532 00 29-78	Gearshift Cap
32	532 00 62-77	Dowel Pin	86	532 12 46-82	Gearshift Ball Cover and Pin
33	532 00 42-25	Needle Bearing	87	532 12 47-04	Shift Lever Guide Ball, Keyed
34	532 00 73-96	Thrust Bearing Race	88	532 00 49-24	Spring
35	532 00 41-98	4th Reduction Gear Shaft	89	819 15 15-16	Washer 15/32 x 15/16 x 16 Gauge
36	532 12 46-63	4th Reduction Gear Spacer	90	532 11 05-42	Shift Mechanism Seal
37	532 00 73-95	Thrust Bearing Race	91	819 18 15-11	Washer 9/16 x 15/16 x 12 Gauge
39	532 13 95-36	Gearcase and Bearings, L.H. (Includes Key Numbers 18, 25, 49, 50 (2), 51 and 52)	92	532 00 00-75	Gearshift Gate and Reinforcement
40	813 32 04-00	Pipe Plug 1/2-14 N.P.T.	93	532 00 62-74	Shift Ball Cover Gasket
41	817 58 05-20	Bolt, Hex 5/16-18 UNC x 1-1/4	94	876 02 04-12	Cotter Pin 1/8 x 3/4
45	532 00 62-71	Oil Seal	95	810 04 05-00	Washer, Lock 5/16
46	813 06 02-00	Pipe Plug 1/4-18 N.P.T.	96	874 76 05-14	Bolt, Hex Head 5/16-18 UNC x 7/8
49	532 12 47-92	Needle Bearing	97	532 12 48-63	Gear Shift Lever Assembly
50	532 00 42-22	Needle Bearing	98	532 14 03-32	Transaxle, 6 Speed, Complete Assembly
51	532 00 15-29	Needle Bearing			

NOTE: All component dimensions given in U.S. inches
 1 inch = 25.4 mm