

INSTALLATION INSTRUCTIONS FOR BAGGER KIT 539106667 FOR DT22 UNITS



WARNING!

DO NOT use or start the engine until the catcher bag is in place.



WARNING!

Machines equipped with a catcher **MUST** not be used with defective catcher bags or without the catcher bag in place. They pose a risk of thrown stones, eye injury and inhalation of dust.



WARNING!

DO NOT attempt to unblock bagger chute while engine is running. Stop engine before removing grass and debris.

1. Remove rear cover, it is not used with the bagger attachment.
2. Disconnect cable on handle, remove clutch bail from handle.
3. Remove handle from unit saving hardware.
4. Place a stable support under the rear frame to support the unit when the rear wheels are removed.
5. Remove the two (2) retaining rings on the rear wheel (they are not reusable, new rings are provided in the kit). Remove wheel from rear axle. (Some models use a cotter pin instead of retaining rings.)
6. Loosen one (1) set screw on the locking collar. Using a punch loosen the locking collar on the rear axle. Repeat on the other side of unit.
7. Remove rear axle from unit. The wheel that is pinned to the axle can remain on the axle.

MANUAL 539107314 REV. 05 (03-09-04)

NOTE: If axle is rusty, remove rust with fine sandpaper.

NOTE: Rubber flap guard does not have to be removed.

8. Remove bearings from the frame, retain hardware.
9. Install tray matching screw holes in main frame. See Figure 1.

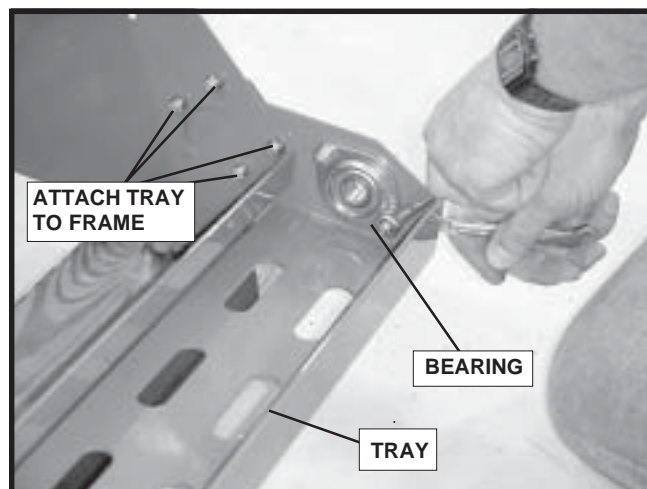

FIGURE 1

10. Apply bearings on the inside of the tray, **DO NOT** tighten hardware, just snug it. See Figure 1.

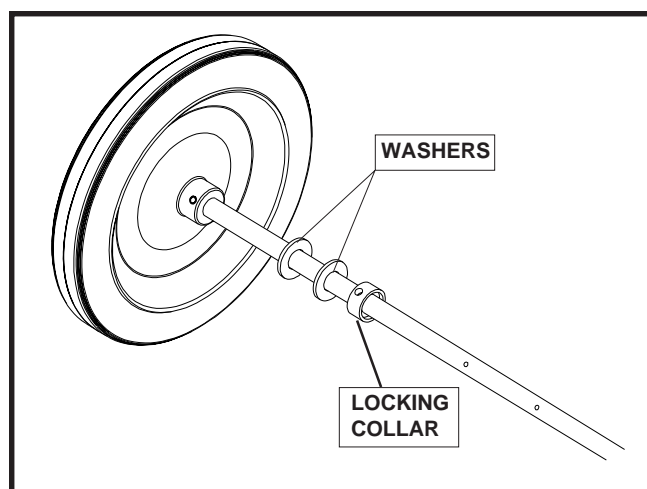

FIGURE 2

11. Add two (2) 5/8" washers locking collar to shaft, install shaft through bearings and tray. Place the other locking collar on the shaft. See Figure 2. Using a punch tighten the locking collars, then tighten the set screw. Repeat for the other side.

- Slide two (2) 5/8" washers onto the axle. Slide wheel on and apply two (2) retaining rings. (Some units have a cotter pin and another 5/8" washer instead of retaining rings.)

NOTE: The teeth on the retaining rings should point away from the wheel.

- Tighten wheel bearing hardware on both sides.
- Install the additional 24 blades onto the shaft assembly. When finished, there will be only one (1) spacer between each blade, you will have eight (8) spacers left over. See Figure 3.

NOTE: If you have not installed the flail reel shaft, do so now.

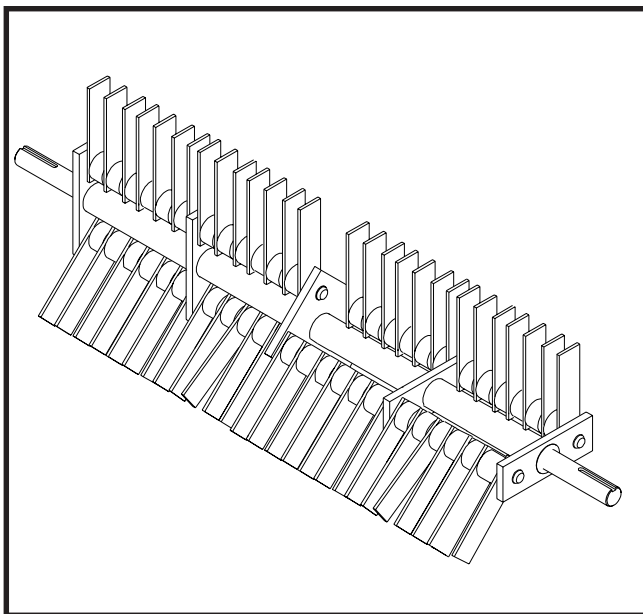

FIGURE 3

- Remove belt guard. Remove cable by removing the small idler pulley. See Figure 4. Attach new cable and replace pulley. Save the old cable for use when the bagger is not used.

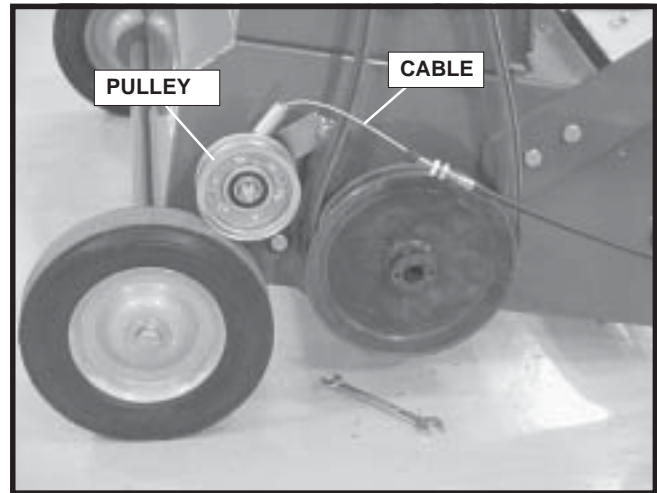

FIGURE 4

- Attach the chute to the mainframe.

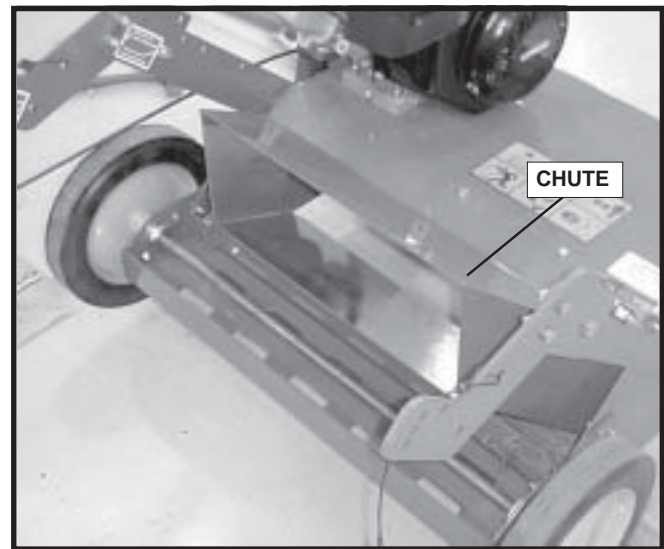

FIGURE 5

- Install two extenders on the outside of the lower handle assembly. Attach the lanyards with pins to the extenders as shown in Figure 6.

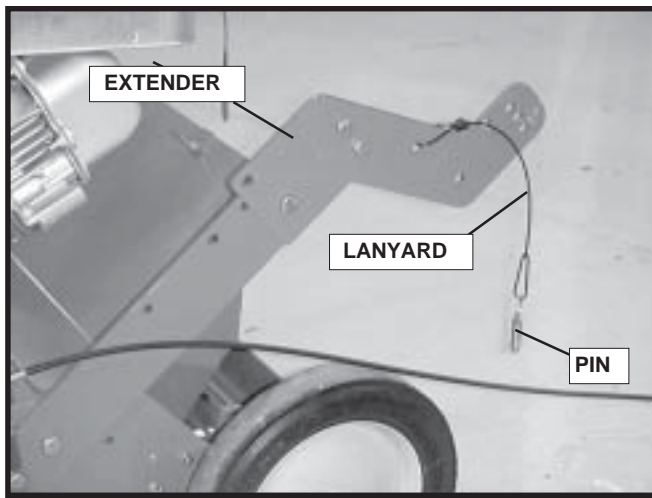

FIGURE 6

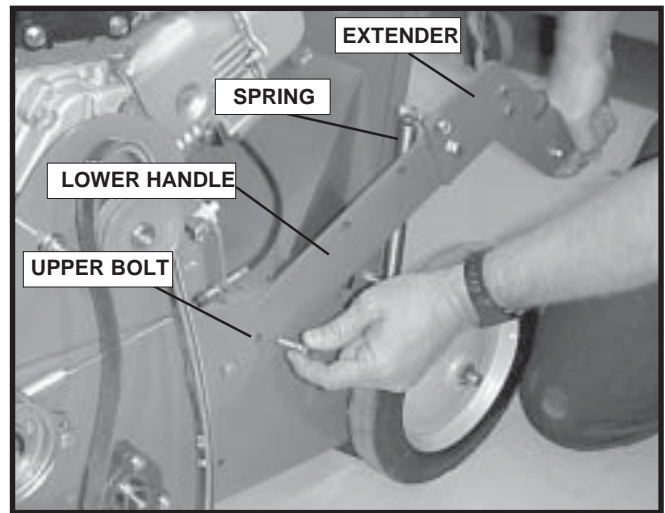

FIGURE 8

18. Place door in position and set the hinge bolts. DO NOT tighten the bolts, leave 1/16" space. Thread nut on to the bolt. See Figure 7

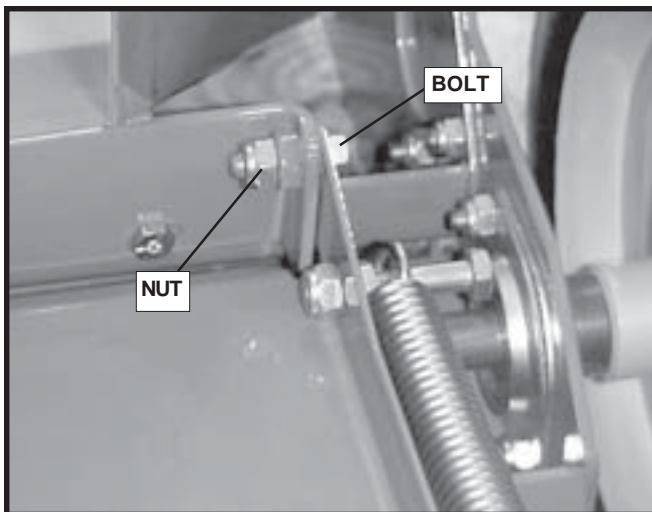

FIGURE 7

20. Attach upper handle to the extenders.

21. Attach upper end of cable to the handle and install cable through clutch bail. Fit clutch bail into the handle. See Figure 9.

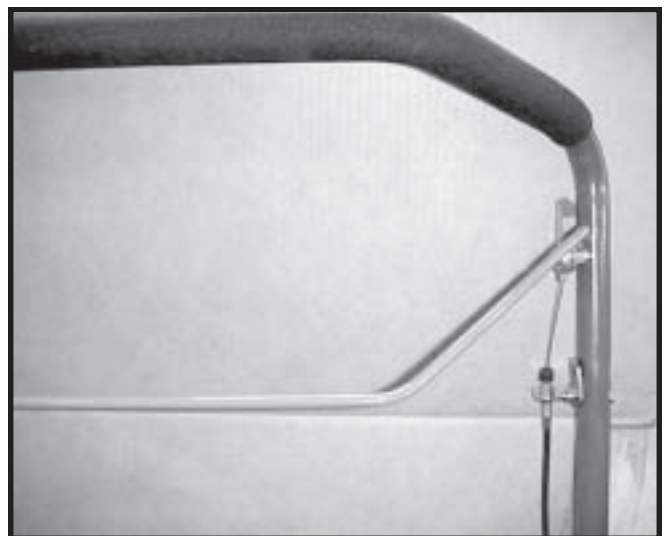

FIGURE 9

19. Remove upper bolt from lower handle and rotate handle toward the ground. Using the hardware provided install the spring to the extender. Rotate handle back to original position stretching spring, re-install the 3/8" bolt into the lower handle. Repeat on other side. See Figure 8.

22. Wire tie the cable to the handle. See Figure 10.

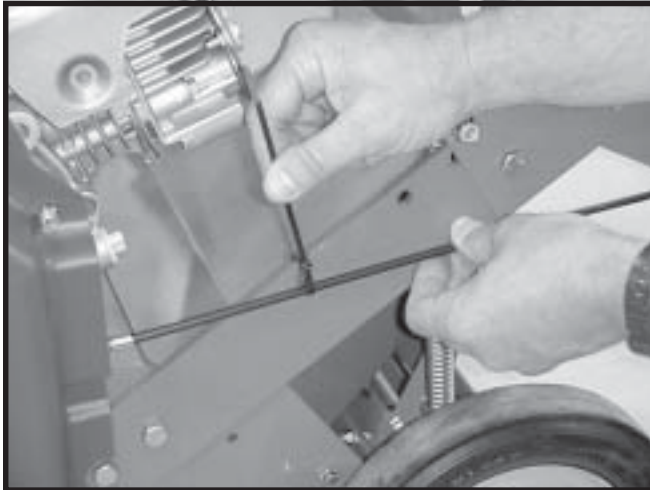

FIGURE 10

23. Check adjustment of clutch cable. If cable needs adjusting, the adjusting should be done at the lower end with the spring.

Adjust as follows:

Pull the clutch bail tightly against the handle.

The spring stretch must be 3/8" - 1/2".

If this range is not met, the adjustment should be done closest to the spring.

24. Replace belt cover.



WARNING!

DO NOT use or start the engine until the catcher bag is in place.



WARNING!

Machines equipped with a catcher **MUST** not be used with defective catcher bags or without the catcher bag in place.

They pose a risk of thrown stones, eye injury and inhalation of dust.

25. Fit catcher bag to the bag frame as follows:

- Affix the bag's plastic rails to the frame.
- Install the upper portion of the bag between the two struts on the upper portion of the frame and affix the bag to the front edge of the frame.
- Press on the snaps, one on each side. See Figure 11.

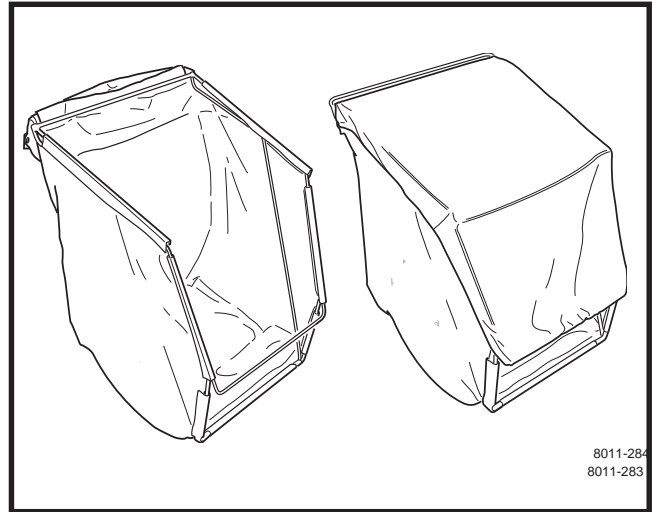

FIGURE 11

26. Attach bag to unit.



FIGURE 12

PARTS ILLUSTRATION

KIT CONTENTS

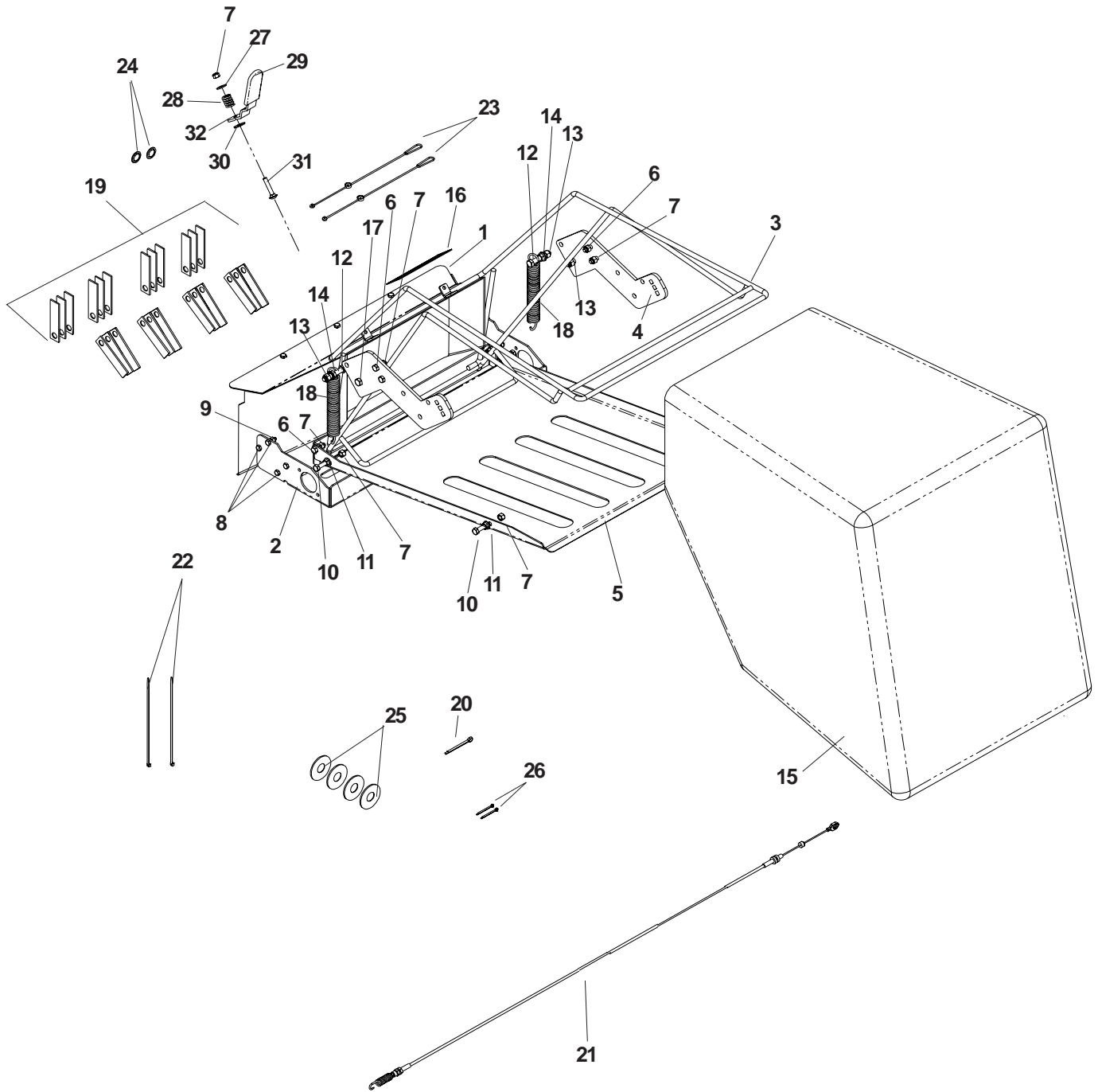

ITEM	PART NO.	QTY	DESCRIPTION
1	539106799	1	CHUTE
2	539106803	1	TRAY
3	539107242	1	BAG FRAME, BLACK
4	539106846	2	EXTENDER
5	539106835	1	SAFETY DOOR
6	539990209	6	SCREW, 5/16 X 1
7	539990717	10	NUT, 5/16, NYLOC
8	539990580	13	SCREW, 1/4 X 3/4
9	539976978	13	NUT, 1/4, NYLOC
10	539990669	3	SCREW, 5/16 X 1 3/4
11	539990585	3	NUT, 5/16, SERRATED WASHER
12	539990588	2	SCREW, 3/8 X 2
13	539976979	4	NUT, 3/8, NYLOC
14	539990613	2	NUT, 3/8, SERRATED WASHER
15	540005464	1	BAG
16	539976583	1	DECAL, WARNING
17	539990563	2	SCREW, 3/8 X 1
18	539107315	2	SPRING, BAGGER
19	539109771	1	BLADE SET (56)
20	539990297	1	COTTER PIN 1/8 X 1 1/2 (FOR REAR AXLE)
21	539106827	1	CABLE, BAGGER
22	539976856	2	WIRE TIE
23	539102563	2	LANYARD
24	540053411	2	RETAINING RING
25	539000436	4	WASHER, 5/8, SAE (FOR REAR AXLE)
26	539099037	2	COTTER PIN, 3/32 X 3/4
27	539990692	1	WASHER, 5/16
28	539976438	1	SPRING
29	539110865	1	GRIP
30	539990517	1	WASHER, 3/8
31	539990861	1	RHSNB, 5/16-18 X 1 3/4
32	539110982	1	BAG CLAMP

NOTE: Ref. No. 22 is used for attaching cable to extender.
 Ref. No. 23 is used for reattaching pin to extender.
 Ref. No. 24 is used for reinstalling tire to axle.

Some models use a metal removable lanyard. For those models the plastic lanyard is not necessary (item 23).

Some models use a cotter pin in the rear axle. For those models (item 24) retaining ring is not necessary.