

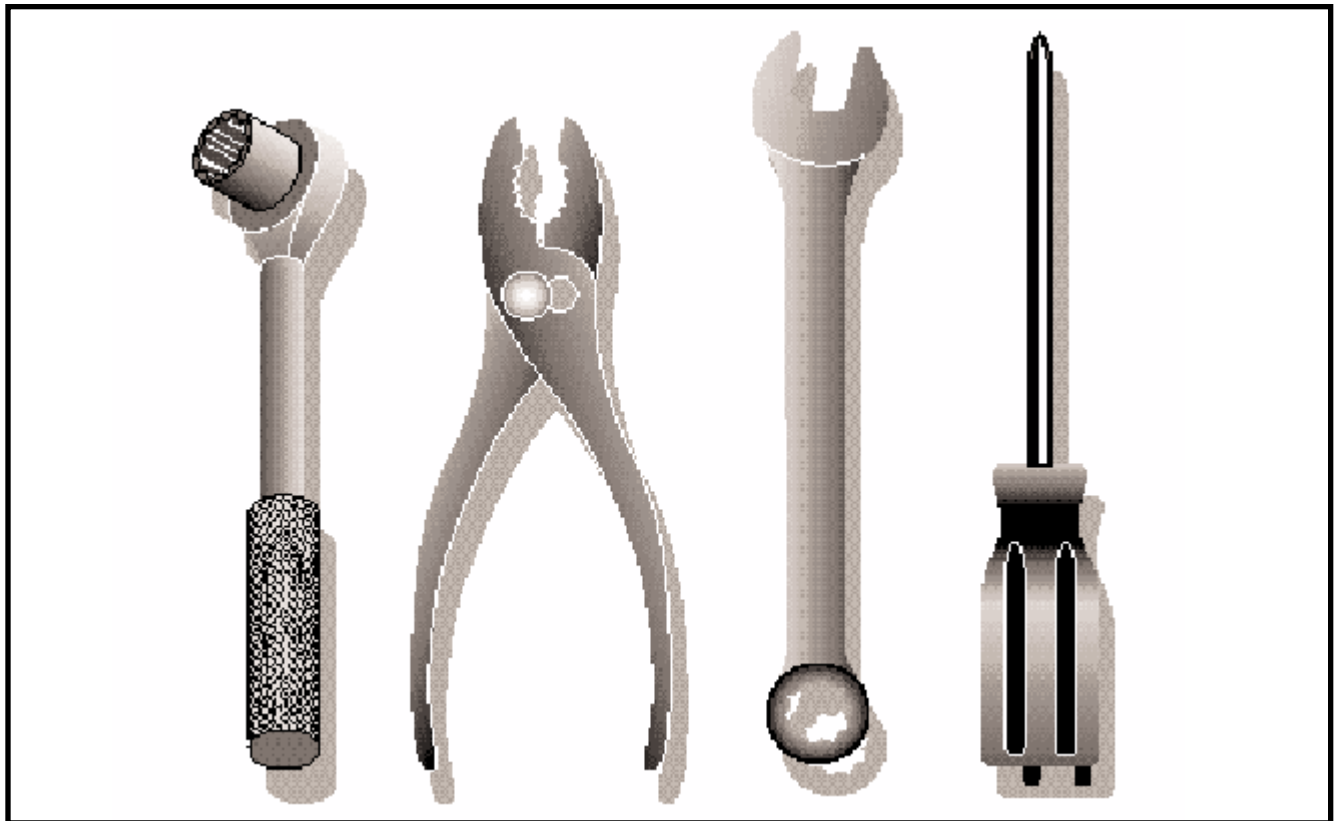

Illustrated Parts List	2001-05
	I0102017

GTH 2550 B

954567109



Repair Parts Manual

Ride Mower

SCHEMATIC

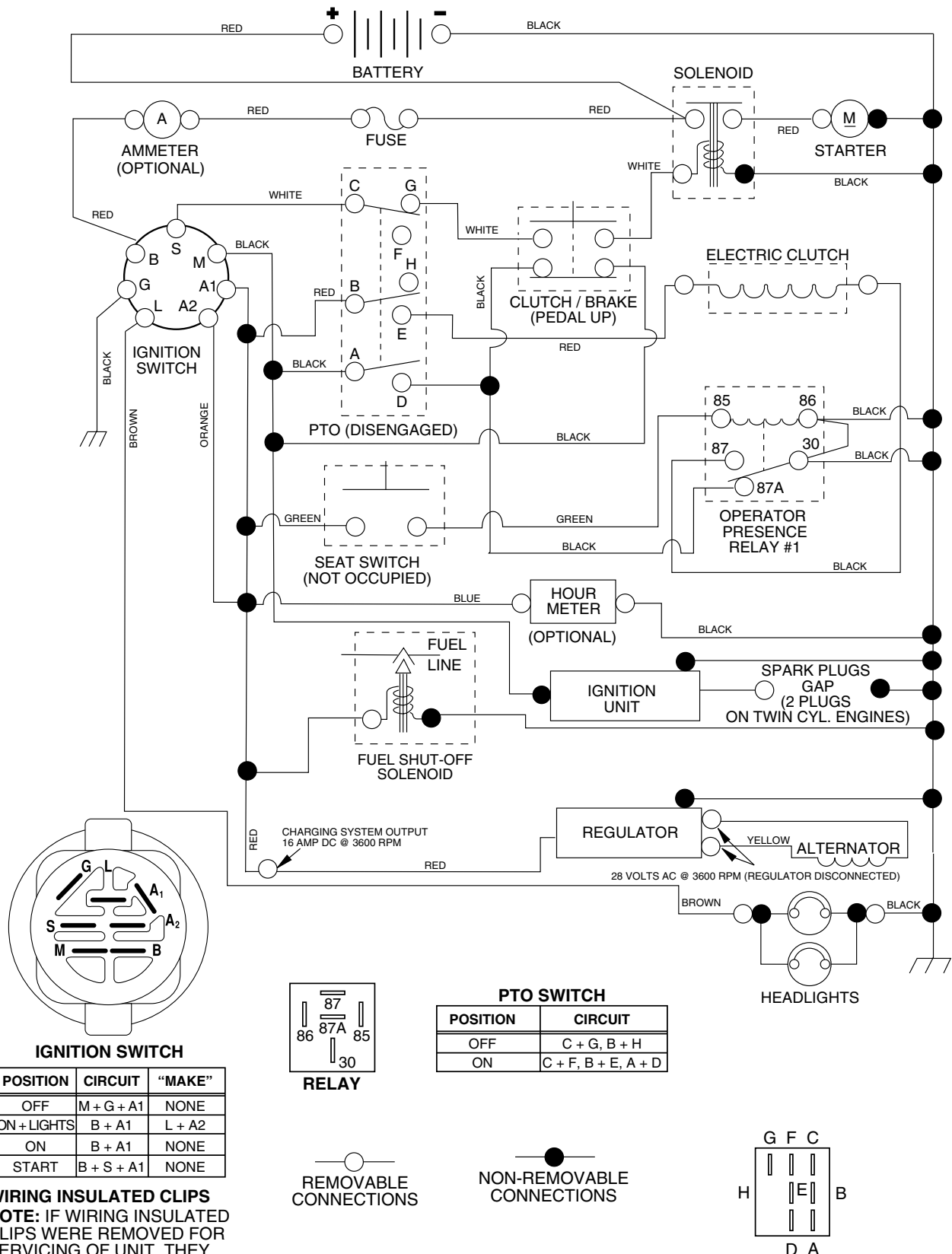

REPAIR PARTS

TRACTOR - - MODEL NO. GTH2550B

ELECTRICAL

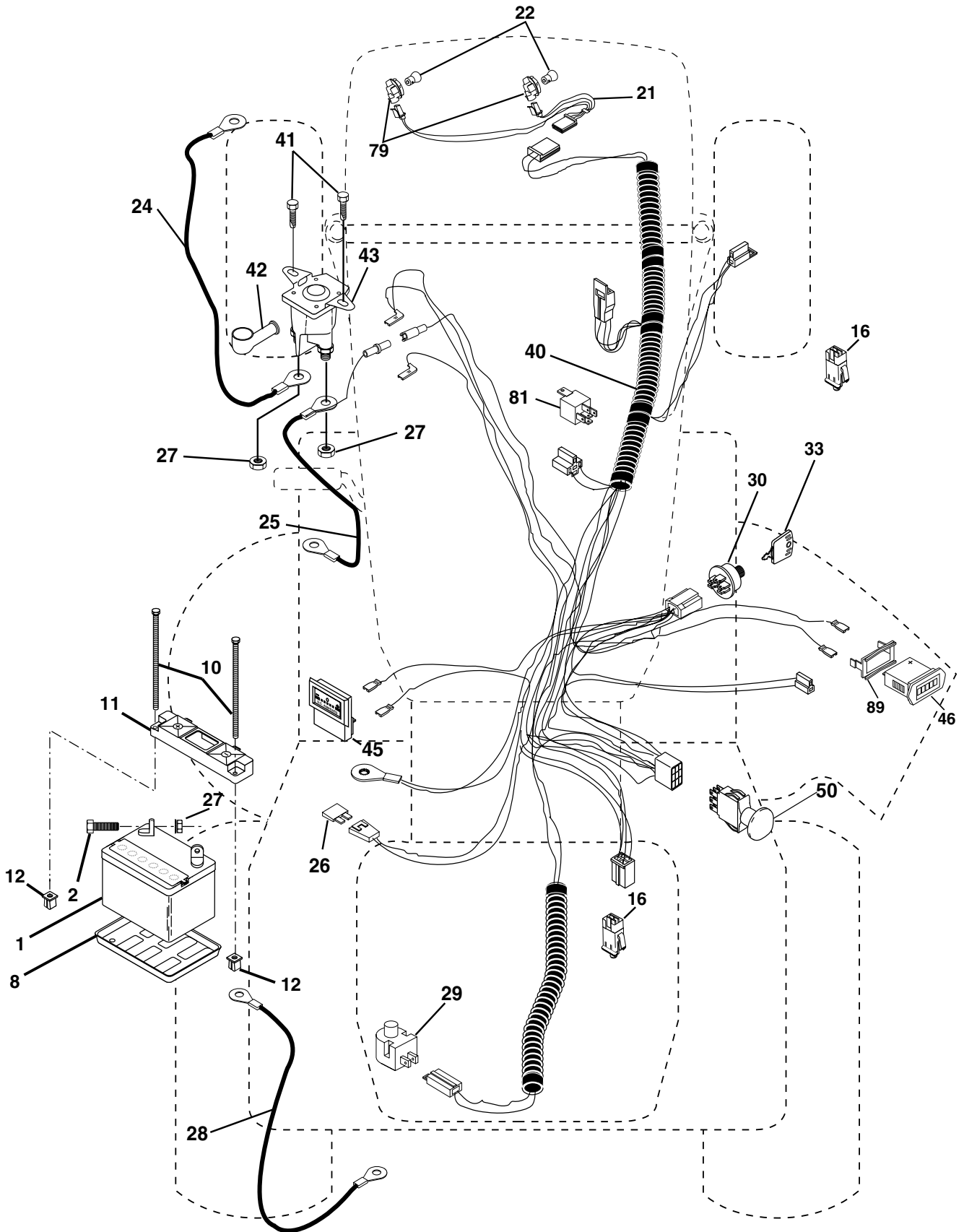

REPAIR PARTS

TRACTOR - - MODEL NO. GTH2550B

ELECTRICAL

KEY NO.	PART NO.	DESCRIPTION
1	532144926	Battery
2	874760412	Bolt Hex Head 1/4-20 x 3/4
8	532124886	Tray, Battery
10	532145211	Bolt, Battery Front 1/4-20 x 7.5 Zinc
11	532150109	Holddown Battery Front Mount
12	532145769	Nut, Push Nylon 1.4" Battery Front
16	532153664	Switch Interlock Push-In
21	532166184	Harness Socket Light w/4152J
22	532004152	Bulb Light
24	532124770	Cable, Battery
25	532146149	Cable, Battery
26	532108824	Fuse
27	873510400	Nut Keps Hex 1/4-20
28	532170697	Cable, Ground
29	532160784	Switch, Plunger Normal Op Olive
30	532175566	Switch, Ign
33	532140401	Key
40	532170238	Harness Ign.
41	817720408	Screw 1/4-20 x 1/2
42	532131563	Cover, Terminal Red
43	532178861	Solenoid
45	532122822	Ammeter
46	532169635	Hourmeter Snap-In
50	532174651	Switch, PTO
79	532163996	Bulbholder Asm
81	532109748	Relay Asm.
89	532169639	Bracket Snap-In Hourmeter

NOTE: All component dimensions given in U.S. inches
1 inch = 25.4 mm

REPAIR PARTS

TRACTOR - - MODEL NO. GTH2550B

CHASSIS AND ENCLOSURES

KEY NO.	PART NO.	DESCRIPTION	KEY NO.	PART NO.	DESCRIPTION
1	532175465	Rail, Frame RH	58	532175315	Bracket Asm., Fender
2	532175282	Drawbar, Gt	60	817060620	Screw 3/8-16 x 1-1/4
4	873800700	Nut, Lock Hex 7/16 Unc	63	819131614	Washer 13/32 x 1 x 14 Ga.
5	532177582	Dash, Plastic	68	817490508	Screw, 5/16-18 x 1/2
6	532157882	Dash, 1PCS, Lower	70	532177679	Belt Keeper VGT Ground
7	817720408	Screw, Thd Cut 1/4-20 x 1/2	84	532142992	Stop, Over Center Mower
8	532145166	Support, Battery	86	874760716	Bolt, Fin Hex 7/16-14 Unc x 1
14	532177583	Hood Asm., Pnt	90	811050600	Washer, Lock External Tooth 3/8
15	532161841	Lens LH	91	532175464	Rail, Frame Lh
16	532121794	Cover, Access	98	532175847	Bracket Chassis Skid
17	817060612	Screw, 3/8-16 x 3/4	99	532140871	Rod Asm. Bypass
18	532177584	Grille	100	532071673	Cap By Pass Rod
19	819131312	Washer 13/32 x 13/16 x 12 Ga.	101	817490628	Screw Thdrol. 3/8-16 x 1-3/4
20	874760616	Bolt, Fin Hex 3/8-16 x 1	102	532124788	Retainer Spring 1"
21	873680600	Nut, Crownlock 3/8-16	103	532142273	Bracket Lock Bypass
24	532147202	Footrest, RH	106	532138776	Screw Thdrol Hex Head Zinc
25	532161842	Lens RH	122	532161464	Screw Hex WSHD 8-18 x 7/8
28	532147203	Footrest, LH	130	532164863	Screw Hw Hd Hi-Lo #13-16 x 3/4
30	532145052	Saddle	138	532166625	Cupholder
31	532161419	Bracket Supt 1-pc Vgt Steering	139	532171873	Bolt Shoulder 5/16-18
32	532161327	Bracket, Frame Pivot Lh	140	532163806	Magnet Stealth
33	532161326	Bracket, Frame Pivot Rh	141	532163805	Striker Plate
34	532177018	Plate Asm Engine Chassis	142	532161897	Bracket Dash Stealth RH
35	819111116	Washer 11/32 x 11/16 x 16 Ga.	143	532177586	Skirt Grille RH
36	817060512	Screw 5/16-18 x 3/4	144	532161900	Bracket Dash Stealth LH
37	532169426	Fender, Pnt.	146	532177587	Skirt Grille LH
39	532175278	Bracket, Axle Front	148	532164655	Extrusion Bumper
42	872140608	Bolt Rdhd Sqnk 3/8-16 Unc x 1	150	532161237	Duct Heat Hood
43	532136939	Bracket, Spnsn Front Lh	152	532177956	Browning Shield
44	532136940	Bracket, Spnsn Front Rh	153	532177585	Lens Asm Headlht Dual
45	532154913	Bracket Asm., Susp Chassis Rh	158	817670608	Screw Thdrol 3/8-16 x 1/2
47	817490608	Screw Thdrol 3/8-16 x 1/2			
50	532175476	Bracket, Chassis Front			
56	532154914	Bracket Asm., Susp Chassis Lh			

NOTE: All component dimensions given in U.S. inches
1 inch = 25.4 mm

REPAIR PARTS

TRACTOR - - MODEL NO. GTH2550B

GROUND DRIVE

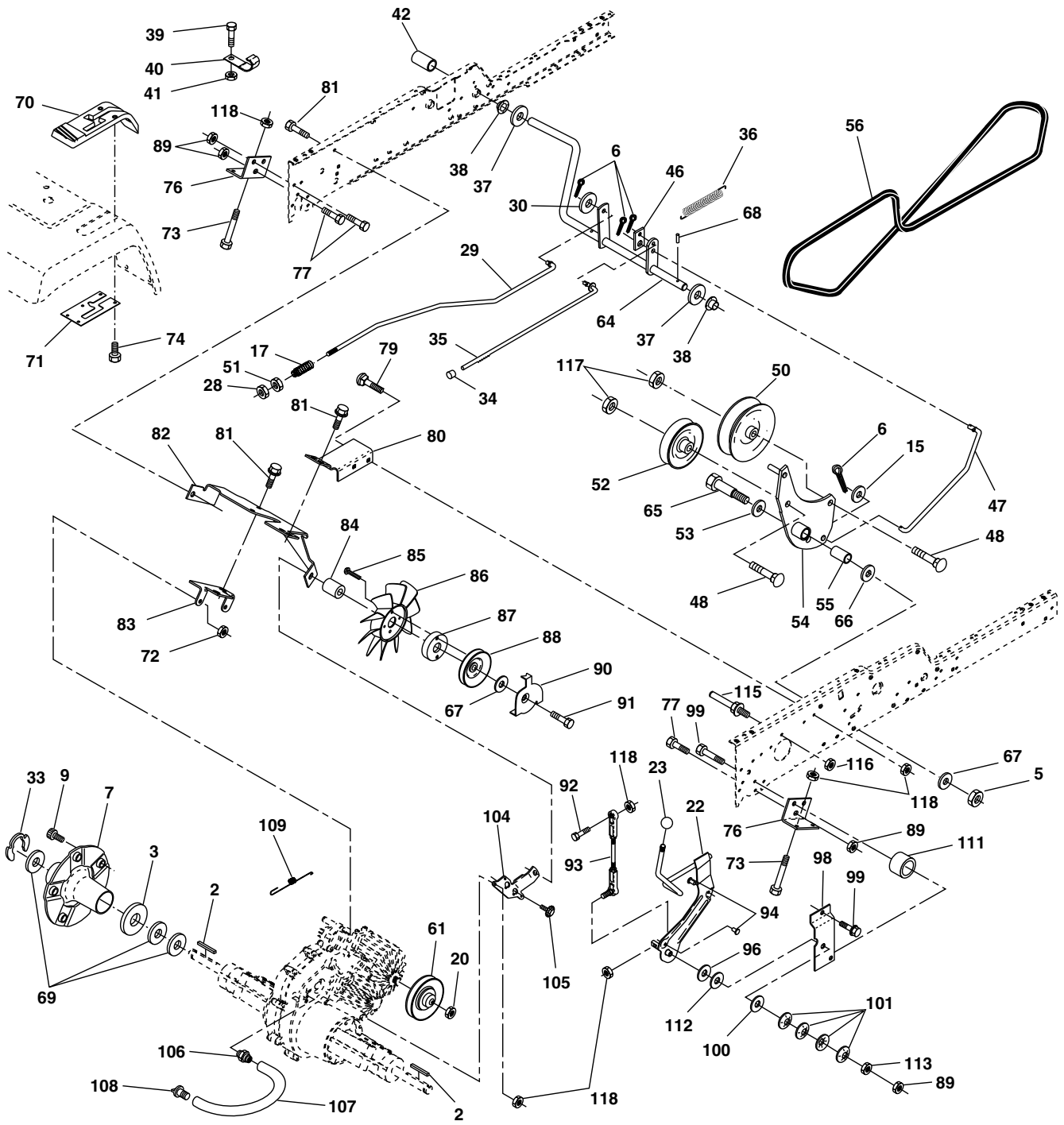

REPAIR PARTS

TRACTOR - - MODEL NO. GTH2550B

GROUND DRIVE

KEY NO.	PART NO.	DESCRIPTION	KEY NO.	PART NO.	DESCRIPTION
	-----	Transaxle, Hydro 222-3010 (Order Parts From Transaxle Manufacturer)	69	532123800	Washer
2	532007070	Key 1/4 x 2.5	70	532166624	Console Hydro Fender
3	532007563	Washer Thrust Axle Harden	71	532151179	Plate Console Shift
5	873680600	Nut Crownlock 3/8-16	72	873800500	Locknut Hex W/Washer Insert
6	876020412	Pin Cotter 1/8 x 3/4	73	874490548	Bolt Hex Flghd 5/16-18 x 3 Gr. 5
7	532140507	Wheel Hub Asm.	74	532142432	Screw, Hex Wsh Hi-Lo 1/4-1/2
9	532140080	Bolt Hub	76	532140481	Bracket Transaxle
15	819131316	Washer 13/32 x 13/16 x 16 Ga.	77	874760716	Bolt Fin Hex 7/16-14 x 1
17	532140921	Spring Rod Brake	79	872110505	Bolt Carriage 5/16-18 x 5/8
20	873940800	Nut Hex Jam Toplock 1/2-20	80	532140484	Bracket Torque RH
22	532156103	Shaft Arm Asm	81	817060612	Screw 3/8-16 x 3/4
23	532140845	Knob	82	532150586	Bracket Mount Torque/Fan
28	873350600	Nut, Hex Jam 3/8-16	83	532140479	Strap Torque Mid
29	532140494	Brake Rod	84	532140490	Spacer
30	819131616	Washer 13/32 x 1 x 14Ga	85	817541020	Screw #10-24 x 1-1/4
33	812000053	Ring E	86	532140462	Fan 7" Hydro
34	532071673	Cap Plunger	87	532140491	Adapter Fan
35	532137648	Rod Parking Brake	88	532161592	Pully Idler V-Groove Flange
36	532149412	Spring Extension	89	873680700	Nut, Crownlock 7/16-14
37	532121749	Washer 25/32 x 1-1/4 x 16 Ga.	90	532140489	Keeper Belt
38	532150035	Nyliner	91	817490644	Screw Thdrol 3/8-16 x 2-3/4
39	874321016	Screw Fin #10-24 x 1	92	874760520	Bolt Fin Hex 5/16-18 x 1.75
40	532178575	Actuator Interlock Switch	93	532140502	Link Shift Asm
41	873931000	Nut Toplock #10-24 Unc	94	532133835	Fastner Christmas Tree
42	532124872	Cover Pedal	96	532141103	Washer Nickel Plated
46	532145170	Retainer Spring	98	532141004	Bracket Shift
47	532138228	Clutch Rod	99	817060624	Screw 3/8-16 x 1-1/2
48	872110612	Bolt Carriage 3/8-16 x 1-1/2 Gr. 5	100	532126881	Washer Compression
50	532131494	Pulley Idler Flat	101	532156106	Washer Bellville
51	873680600	Nut, Crownlock 3/8-16	104	532140480	Bracket Idler
52	532139123	Pulley Idler Grooved	105	817580408	Screw Tap 1/4-20 x 1/2
53	532000207	Washer Hardened	106	532142918	O-Ring Asm Hydro Gear
54	532161590	Arm Asm Idler Clutch 98	107	532154739	Line Fuel Hydro 15" VGT Serv
55	532105706	Bearing, Idler	108	532142917	Cap Asm Vent Hydro Gear
56	532140218	V-Belt	109	532140929	Spring Return Brake
61	532140488	Pulley Transaxle	111	532156240	Spacer Shift Lever VGTH
64	532154752	Shaft Asm Brake Parking Clutch	112	532156104	Washer Nylon High Temp
65	532067609	Bolt Shoulder	113	873220700	Nut Hex ASF 7/16-14 Unc
67	819131312	Washer 13/32 x 13/16 x 12 Ga	115	532123405	Keeper Belt T/A GND DR LR
68	532005142	Pin Roll	116	873900500	Nut Lock Hex Flange 5/16-18
			117	873900600	Nut Lock Flg. 3/8-16 Unc

NOTE: All component dimensions given in U.S. inches
1 inch = 25.4 mm

REPAIR PARTS

TRACTOR - - MODEL NO. GTH2550B

STEERING ASSEMBLY

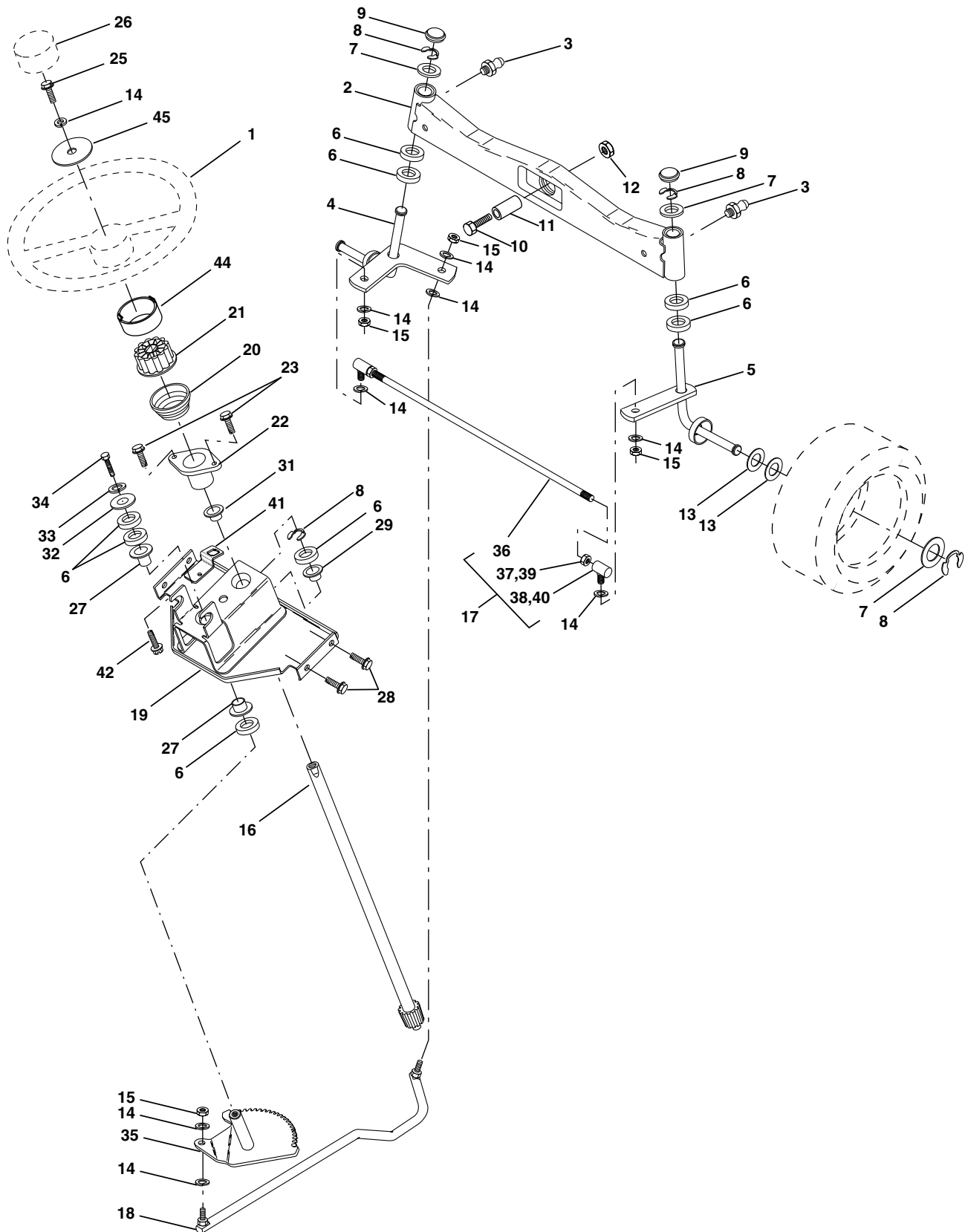

REPAIR PARTS

TRACTOR - - MODEL NO. GTH2550B

STEERING ASSEMBLY

KEY NO.	PART NO.	DESCRIPTION
1	532166627	Wheel, Steering
2	532178557	Axle Asm., Front
3	532124836	Fitting, Grease
4	532161849	Spindle Asm, LH
5	532161848	Spindle Asm., RH
6	532124931	Bearing, Race Thrust Harden
7	532121748	Washer 25/32 x 1-5/8 x 16 Ga.
8	812000029	Ring, Klip #T5304-75
9	532121232	Cap, Spindle
10	874781044	Bolt, Fin Hex 5/8-11 x 2-3/4
11	532136518	Spacer Brg Axle Front 1.570
12	873901000	Nut, Lock Flange 5/8-11 Unc
13	532121749	Washer 25/32 x 1-1/4 x 16 Ga.
14	810040600	Washer, Lock Hvy Hlcl Spr 3/8
15	532124701	Nut Lock Center 3/8-24 Unf
16	532145103	Shaft Asm., Steering
17	532137347	Rod Asm., Tie Ball J Ball Vgt (Inc. Key No. 36-40)
18	532175572	Draglink, Ball Joint Solid Vgt
19	532156011	Support Asm., Steering Vgt
20	532177592	Boot Steering
21	532159945	Adapter, Wheel Steering
22	532155105	Bushing, Strg.
23	532152927	Screw
25	874780616	Bolt, Fin Hex 3/8-16 x 1 Gr. 5
26	532166626	Cap , Wheel Steering
27	532124937	Bearing, Col. Strg.
28	817000612	Screw 3/8-16 x 3/4
29	532104239	Bearing, Flange
31	532138136	Bushing, Nyliner Snap
32	819111610	Washer 11/32 x 1 x 10 Ga.
33	810040500	Washer, Lock Hvy Hlcl Spr 5/16
34	874780512	Bolt, Hex Hd 5/16-18 x 3/4
35	532138059	Gear, Sector Steering
36	532137156	Tie Rod
37	873360600	Jam Nut RH Thread
38	532109850	Joint Asm. Ball RH Thread
39	873700600	Nut Hex Jam 3/8-24 Unf LF
40	532109851	Joint Asm Ball LH Service
41	532155246	Bracket Switch Inerlock VGT97
42	817490508	Screw 5/16-18 x 1/2
44	532177593	Extension Steering Premium
45	819132411	Washer 13/32 x 1-1/2 x 11 Ga.

NOTE: All component dimensions given in U.S. inches
1 inch = 25.4 mm

REPAIR PARTS

TRACTOR - - MODEL NO. GTH2550B

ENGINE

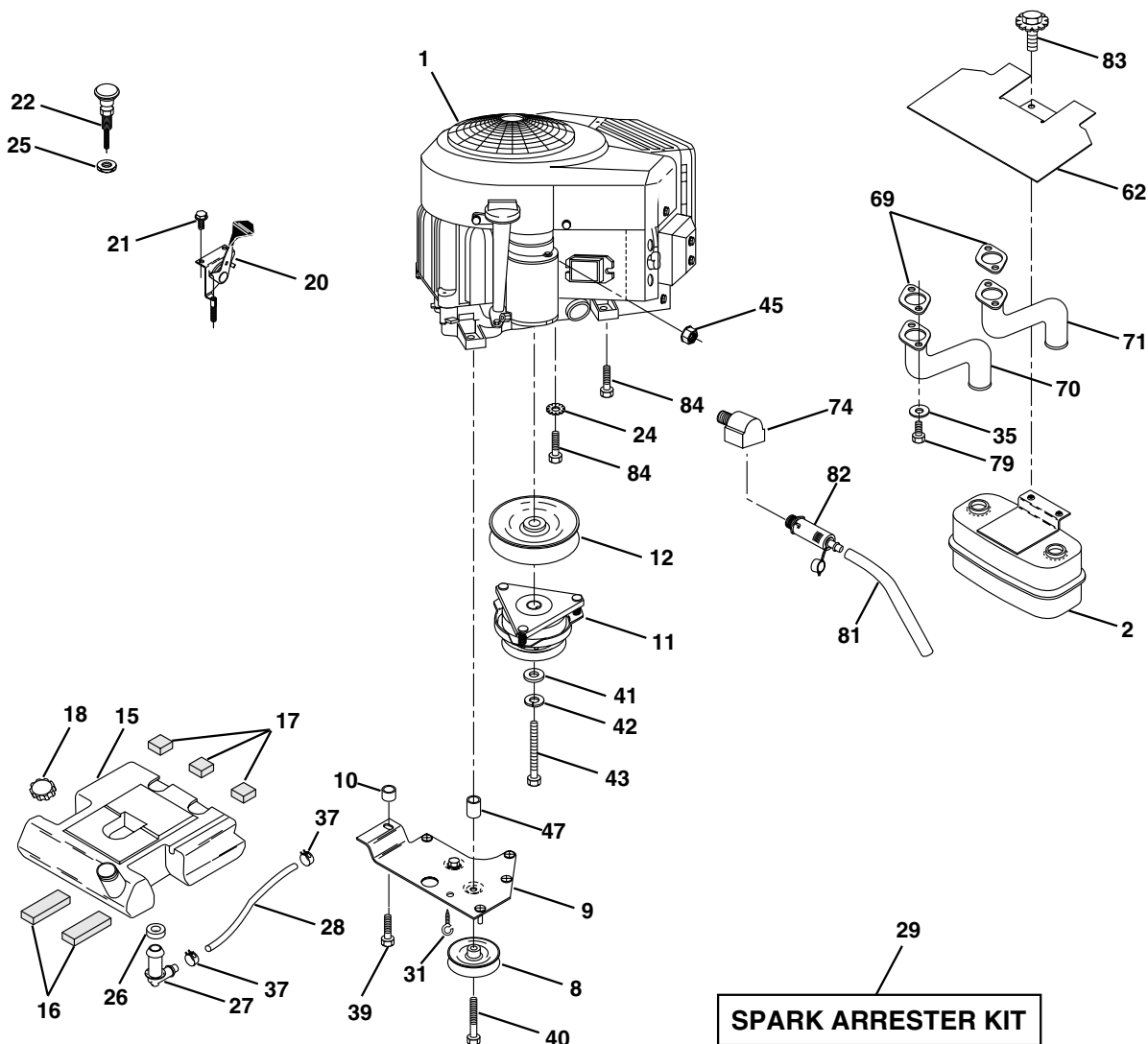

KEY NO.	PART NO.	DESCRIPTION
1	-----	Engine Briggs, Model No. 445777 (Order parts from engine manuf.)
2	532149723	Muffler Side
8	532121361	Pulley V-Idler
9	532177748	Keeper Asm. Belt Engine VGT
10	532175287	Bushing
11	532170056	Clutch Electric
12	532143996	Pulley Engine VGT Elect Clutch
15	532151346	Tank Fuel Rear 3.50
16	532109227	Pad Spacer
17	532106082	Pad Spacer
18	532161493	Cap Fuel
20	532178385	Control Throttle
21	532164863	Screw Hex Thd Cut 1/4 - 20 X 5/8
22	532178639	Control Choke
24	811050600	Washer Ext Tooth 3/8
25	873920600	Nut Keps 3/8-24 Unf
26	532003645	Bushing
27	532139277	Stem Tank Fuel
28	532007834	Fuel Line
29	532137180	Spark Arrester Kit

KEY NO.	PART NO.	DESCRIPTION
31	532145006	Clip
35	810040500	Washer
37	532123487	Clamp Hose
39	817490636	Screw TT 3/8-16 x 2-1/4 UNC
40	817490664	Screw TT 3/8-16 x 4 UNC
41	532126197	Washer 1-1/2 OD X 15/32 ID X .250
42	810040700	Washer Lock 7/16
43	532173937	Bolt Hex 7/16-20 X 4-1/4 Ga 5
45	873510400	Nut Keps Hex 1/4-20
47	532175288	Bushing
62	532146629	Shield Heat Muffler CV-Intek
69	532165391	Gasket
70	532176069	Tube Exhaust LH
71	532176070	Tube Exhaust RH
74	532162295	Elbow Street Brass
79	871070512	Screw Hex Hd Cap 5/16-18 x 3/4
81	532148456	Tube Drain Oil Easy
82	532148315	Plug Oil Drain Easy
83	532171877	Bolt 5/16-18unc X 1-3/4 W/Sems
84	817060624	Screw Thdrol 3/8-16 x 1-1/2

NOTE: All component dimensions given in U.S. inches
1 inch = 25.4 mm

REPAIR PARTS

TRACTOR - - MODEL NO. GTH2550B

SEAT ASSEMBLY

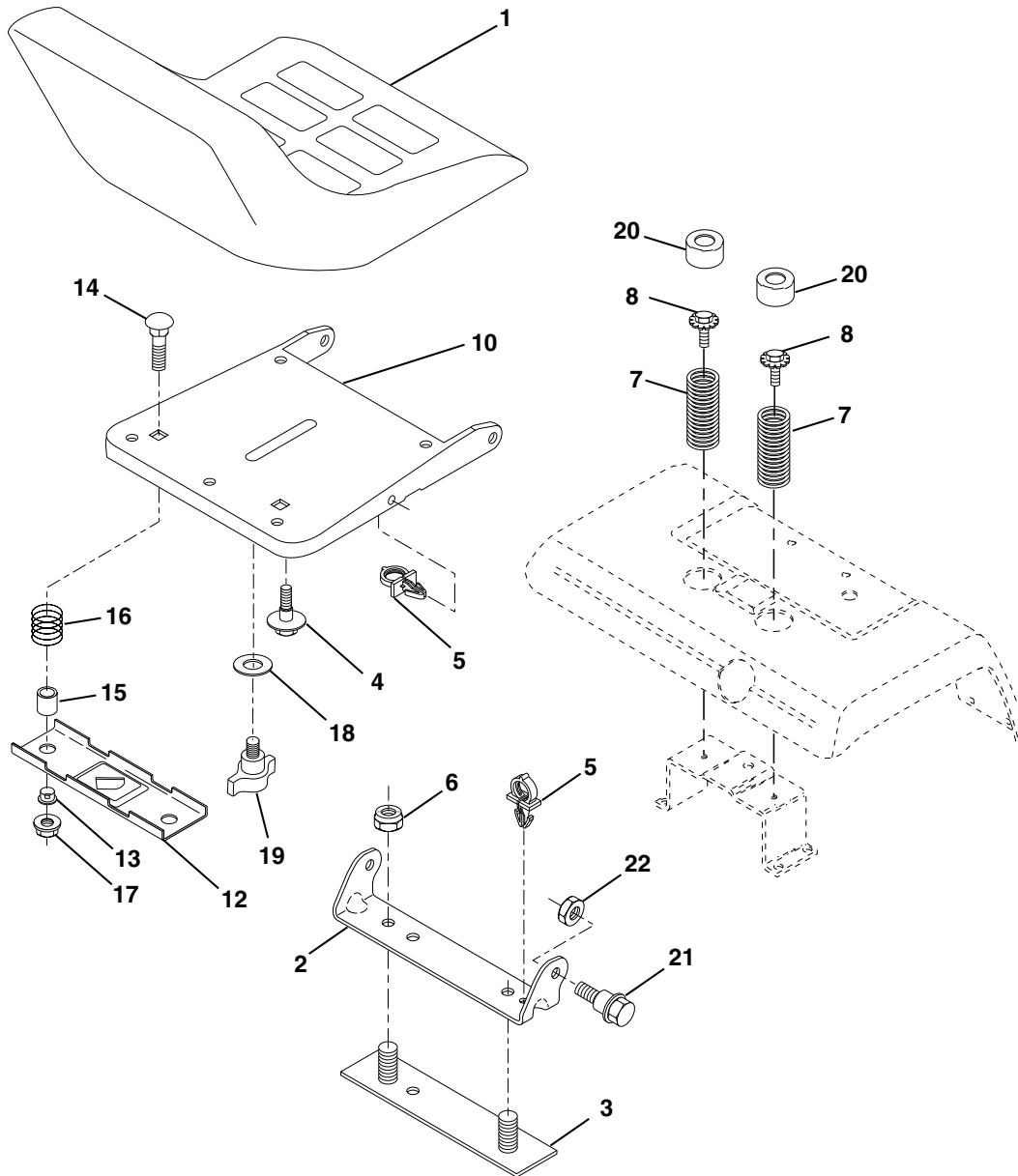

KEY NO.	PART NO.	DESCRIPTION
1	532141525	Seat
2	532140551	Bracket, Pivot Seat
3	532140675	Strap, Fender
4	532127018	Bolt, Shoulder 5/16-18 X .62
5	532145006	Clip, Push In Hinged
6	873800600	Nut, Crownlock 3/8-16
7	532124181	Spring, Seat Cprsn
8	532171877	Bolt 5/16-18 UNC X 3/4
10	532174894	Pan, Seat
12	532121246	Bracket, Mounting Switch
13	532121248	Bushing, Snap

KEY NO.	PART NO.	DESCRIPTION
14	872050412	Bolt, Carriage 1/4-20 X 1-1/2
15	532121249	Spacer, Split
16	532123740	Spring, Cprsn
17	532123976	Nut, Lock 1/4 Lge Flg Gr. 5
18	819171912	Washer 17/32 X 1-3/16 X 12 Ga.
19	532166369	Knob, Seat
20	532124238	Cap, Spring Seat
21	532171852	Bolt, Shoulder 5/16-18
22	873800500	Nut, Crownlock 5/16-18

NOTE: All component dimensions given in U.S. inches
1 inch = 25.4 mm

REPAIR PARTS

TRACTOR - - MODEL NO. GTH2550B

DECALS

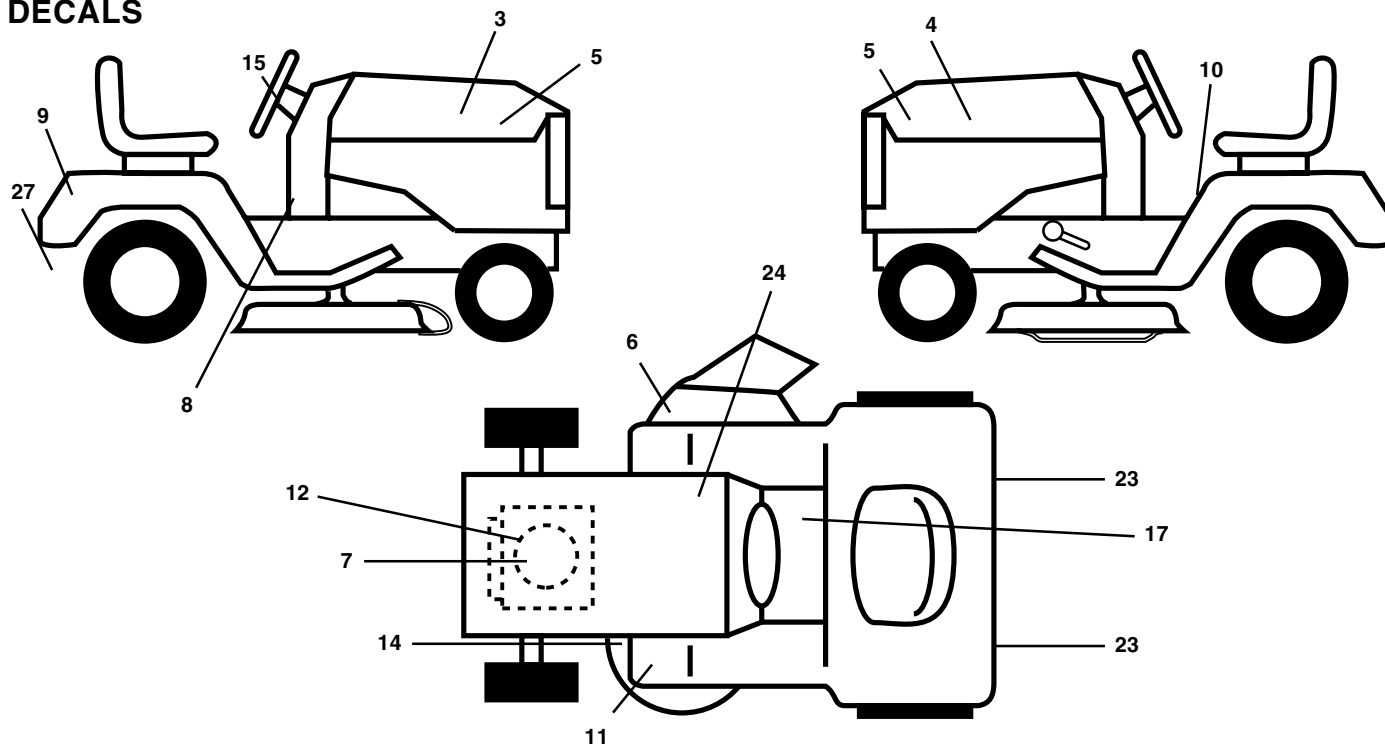

KEY PART NO.

KEY NO.	PART NO.	DESCRIPTION
3	532176866	Decal, Hood, RH
4	532176867	Decal, Hood, LH
5	532176776	Decal, Side Panel
6	532170563	Decal, Warning
7	532176865	Decal, Engine HP
8	532176864	Decal, Dash
9	532176822	Decal, Fender
10	532157140	Decal, Danger
11	532101892	Decal, Clutch/Brake
12	532176775	Decal, Engine RCL

KEY PART NO.

KEY NO.	PART NO.	DESCRIPTION
14	532160397	Decal, V-Belt Schematic
15	532170564	Decal, Ins. Strg Whl
17	532140837	Decal, Saddle Brake Parking
23	532106202	Reflector, Taillight
24	532145005	Decal, Btry Dngr/Psn
27	532142342	Decal, Drawbar
--	532138311	Decal, Handle Lift (Lift Handle)
--	532133671	Pad Footrest
--	532178466	Manual, Owner's (English)
--	532178467	Manual, Owner's (French)

WHEELS & TIRES

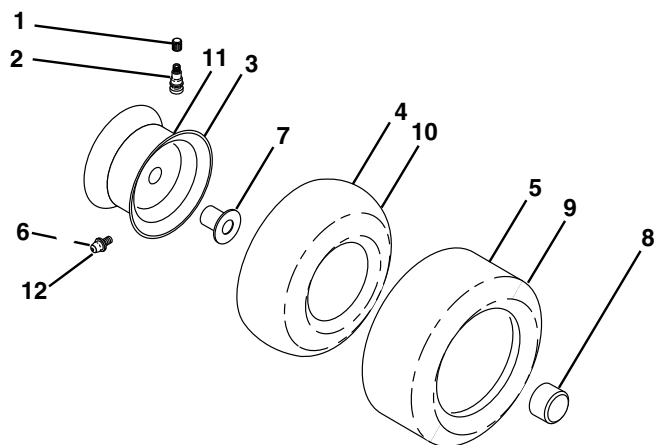

KEY PART NO.

KEY NO.	PART NO.	DESCRIPTION
1	532059192	Cap, Valve, Tire
2	532065139	Stem, Valve
3	532144509	Rim Assembly, Front
4	532008134	Tube, Front (Service Item Only)
5	532106230	Tire, Front
6	532124957	Fitting, Grease
7	532124959	Bearing, Flange (Front Wheel Only)
8	532175039	Cap, Hub
9	532105588	Tire, Rear
10	532007154	Tube, Rear (Service Item Only)
11	532144510	Rim Assembly, Rear
12	532124860	Fitting, Grease
--	532144334	Sealant, Tire (10 oz. Tube)

NOTE: All component dimensions given in U.S. inches
1 inch = 25.4 mm

REPAIR PARTS

TRACTOR - - MODEL NO. GTH2550B

LIFT ASSEMBLY

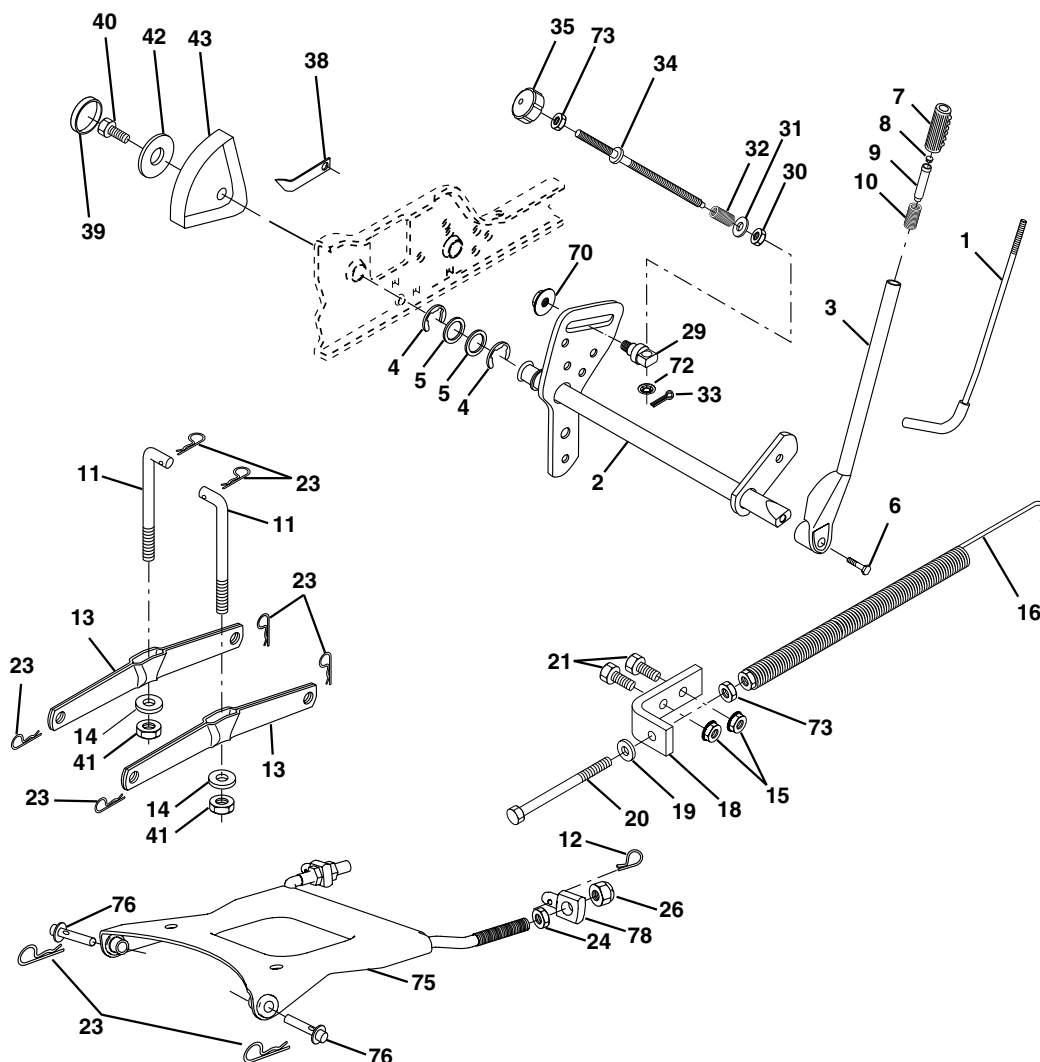

KEY NO.	PART NO.	DESCRIPTION
1	532121006	Rod Asm., Lever
2	532159045	Shaft Asm., Lift Vgt
3	532159189	Lever Asm., Lift Rh
4	812000022	E-Ring Truarc #5133-87
5	819292016	Washer 29/32 x 1-1/4 x 16 Ga.
6	871110624	Bolt, Fin Hex 3/8-16 x 1-1/2
7	532125631	Grip, Handle
8	532124526	Button, Plunger
9	532122364	Plunger, Lever Lift
10	532124874	Spring 2-1/8"
11	532146704	Link Lift
12	532163552	Retainer, Spring
13	532139868	Arm, Suspension Vgt
14	532169865	Bearing
15	873680600	Nut, Crownlock 3/8-16
16	532124687	Spring Asm., Assist Lift
18	532143363	Bracket, Spring Assist
19	819131316	Washer 13/32 x 13/16 x 16 Ga.
20	532005328	Bolt, Adjust Spring Assist
21	874760616	Bolt, Fin Hex 3/8-16 x 1
23	532124670	Retainer, Spring
24	873350800	Nut, Jam Hex 1/2-13 Unc

KEY NO.	PART NO.	DESCRIPTION
26	873800800	Nut, Lock W/Wsh 1/2-13 Unc
29	532150233	Trunnion Infin Height
30	532110807	Nut, Special
31	819131016	Washer 13/32 x 5/8 x 16 Ga.
32	532137150	Spring, Compression Inf Hgt
33	876020308	Pin, Cotter 3/32 x 1/2
34	532137167	Rod, Adj Lift
35	532138057	Knob, Inf 3/8-16 Unc
38	532155097	Pointer Height Indicator
39	532123935	Plug, Hole Blk. 1.485/1.515 Dia.
40	817060516	Screw 5/16-18 x 1
41	873540600	Nut, Crownlock 3/8-24
42	819112410	Washer 11/32 x 1-1/2 x 10 Ga.
43	532123934	Scale, Indicator Height
70	532145212	Nut Hex Flange Lock
72	532110452	Nut Push Phos & Oil
73	873350600	Nut Hex Jam 3/8-16
75	532175805	Plate Asm. Susp front
76	532175560	Pin Flange
78	532130171	Trunnion

NOTE: All component dimensions given in U.S. inches
1 inch = 25.4 mm

TRACTOR - - MODEL NO. GTH2550B

MOWER DECK

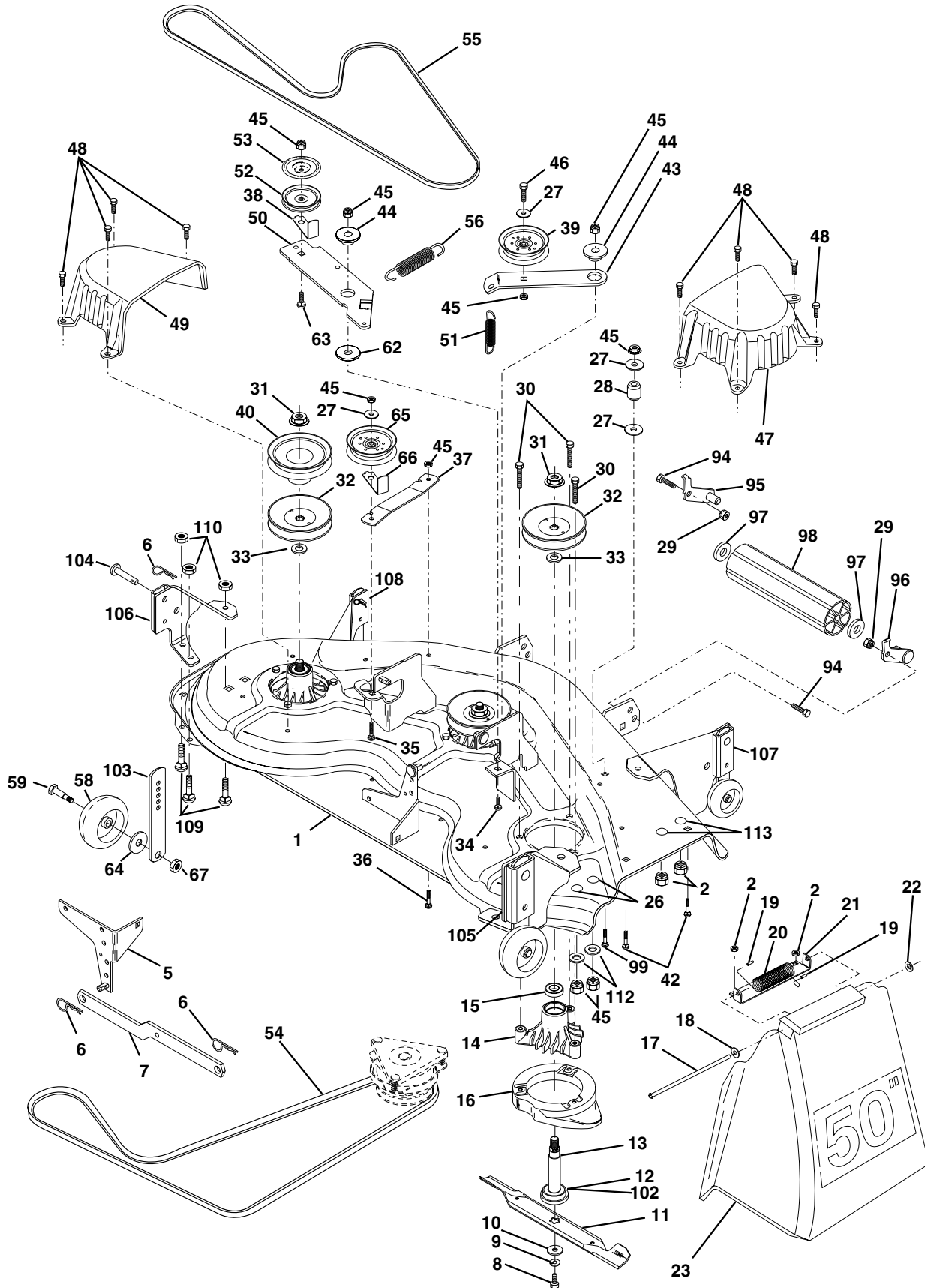

REPAIR PARTS

TRACTOR - - MODEL NO. GTH2550B

MOWER DECK

KEY NO.	PART NO.	DESCRIPTION	KEY NO.	PART NO.	DESCRIPTION
1	532178897	Deck Asm., Mower 50"	46	874760628	Bolt, Fin Hex 3/8-16 Unc x 1-3/4
2	873680500	Nut, Crownlock 5/16-18	47	532137200	Cover, Mandrel RH
5	532138457	Bracket Asm., Sway Bar	48	532137729	Screw, Thd Roll 1/4-20 x 5/8
6	532124670	Retainer, Spring	49	532136574	Cover, Mandrel LH
7	532130832	Arm Suspension, Rear	50	532137272	Arm, Idler Primary
8	532850857	Bolt 3/8-24 x 1.25 Gr. 8 Patched	51	532137273	Spring, Secondary
9	810030600	Washer, Lock Hvy 3/8 Unplated	52	532139245	Pulley, Idler V Groove
10	532140296	Washer, Hard Blade Mower Vented	53	532137789	Shield, Idler
11	532137380	Blade (3 Required)	54	532139573	V-Belt, Mower Primary
13	532137553	Shaft Asm., W/Lower Brg	55	532144959	V-Belt, Mower Secondary
14	532137152	Housing, Mandrel 50" Vent	56	532138687	Spring, Primary
15	532110485	Bearing, Ball Mandrel	58	532133957	Wheel, Gauge
16	532174493	Stripper, Mower	59	532137644	Bolt, Shoulder
17	532106735	Rod, Hinge	62	532133943	Washer Hardened
18	819111016	Washer 11/32 x 5/8 x 16 Ga.	63	872110612	Bolt Carriage 3/8-16 x 1-1/2
19	532105304	Cap Sleeve	64	819121414	Washer 3/8 x 7/8 x 14 Ga.
20	532123713	Spring, Torison Delector	65	532173981	Pulley Idler Flat Mower
21	532137607	Bracket, Deflector	66	532173979	Keeper, Belt Idler 50" Vent
22	532110452	Nut, Push	67	873930600	Nut, Center Lock 3/8-16
23	532171593	Shield, Deflector Mower	94	874780516	Bolt H 5/16-18
26	872110606	Bolt RdHd Sht Sqnk	95	532175746	Bracket, Asm. Noseroller LH
27	819131316	Washer 13/32 x 13/16 x 16 Ga.	96	532175747	Bracket, Asm. Noseroller RH
28	532132823	Spacer, Spring Stop Idler	97	819171416	Washer 17/32 x 7/8 x 16 Ga.
29	873800500	Nut, Lock Hex 5/16-18	98	532132264	Roller, Nose
30	532157722	Screw Thd Rolling Washer Head	99	872110614	Bolt, Carriage 3/8-16 x 1-3/4 Gr. 5
31	532137266	Nut, Flg Top Lock Cntr 9/16	103	532155986	Bar Adj. Gauge Wh.
32	532173436	Pulley, Mandrel	104	532156941	Pin Head Rivot
33	532129963	Washer, Spacer Mower Vented	105	532156852	Bracket Ga Wh Asm RH 50
34	872140610	Bolt, Carriage 3/8-16 x 1-1/4	106	532156853	Bracket Ga Wh Asm LH 50
35	872110616	Bolt, Carriage 3/8-16 x 2	107	532156854	Bracket Ga Wh Assy F RH 50
36	872110608	Bolt, Carriage 3/8-16 x 1 Gr. 5	108	532156856	Bracket Ga Wh Assy F LH 50
37	532137166	Stiffener, Arm Idler	109	872010505	Bolt Carriage 5/16- 18 x 5/8
38	532173968	Keeper, Belt Idler	110	873980500	Nut Crownlock 5/16-18
39	532173438	Pulley, Idler Flat	112	819171216	Washer 17/32 x 3/4 x 16 Ga.
40	532173980	Pulley, Driven	113	872110504	Bolt Carriage 5/16-Unc 1/2
42	872140506	Bolt, Carriage 5/16-18 Unc x 3/4	--	532143651	Mandrel Asm (Includes Key Nos. 8-10, 13-15, 31 and 33)
43	532136460	Arm, Idler Secondary	--	532178346	Replacement Mower, Complete
44	532122052	Spacer, Retainer			
45	873680600	Nut, Crownlock 3/8-16 Unc			

NOTE: All component dimensions given in U.S. inches
1 inch = 25.4 mm