

ST385i String Trimmer UT-15173
Carburetor - Fuel Tank

Page 2 of 10

Ref #	Part Number	Qty	S/P/F	Description
1	UP00020	1	S	FUEL TANK KIT (Includes 2-9)
2	UP00106	1	/P	FUEL CAP (1 5/8" Opening)
3	98792	3	/P	BUMPER-Rubber
4	0143918	1	/P	TUBING-Rubber
5	0143910	1	/P	TUBING-Rubber
6	9477213	1	/P	TUBING-Rubber
7	49422	1	S	FUEL FILTER
8	02067	1	/P	FITTING
9	98268	1	S/P	CLAMP
10	04474	2	/P	SCREW-Machine (10-24 x 2 1/4") (Torque Specs 30-40 In/Lbs, 3.4-4.5 Nm)
11	98768A	1	/P	HEAT DAM
12	093221	2	S/P/F	SCREW, SEMS (10-24 x 1") (Torque Specs 40-50 In/Lbs, 4.5-5.6 Nm, Red 262 Required Loctite)
13	A04445A	1	/P	CARBURETOR KIT (Includes 14-16)
14	98766A	1	S/P/F	GASKET-Carburetor
15	07376	1	/P	LEVER-Choke (Walbro)
	PS00236	1	S	LEVER-Choke (Zama)
16	06900A	1	/P/F	GASKET-Heat Dam

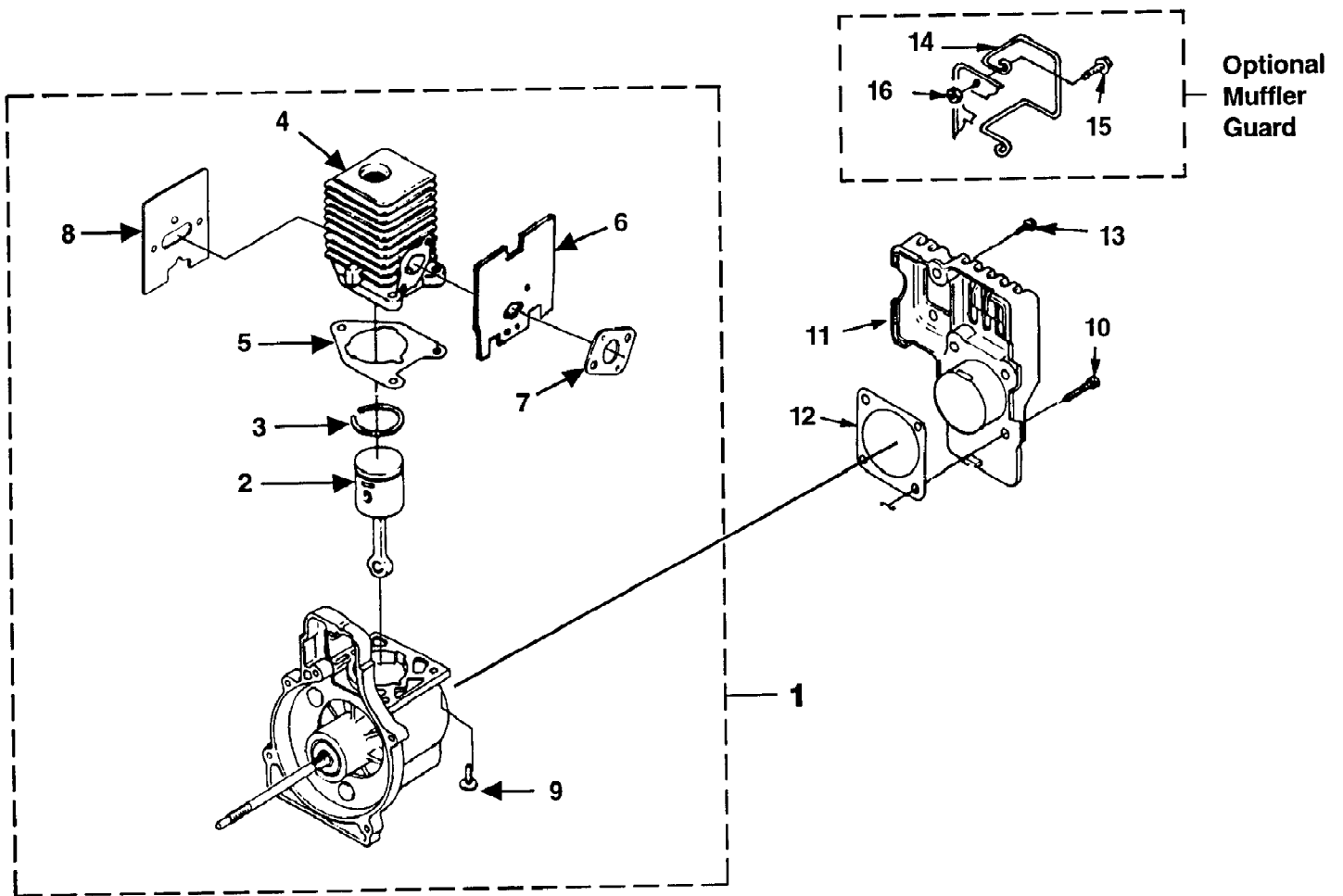

Ref #	Part Number	Qty	S/P/F	Description
1	UP03120	1		SHORT BLOCK (30CC) (Includes 1st 2-10)
2	UP03366	1	S	30CC PISTON & ROD (Includes 3)
3	03179	2	/P	RING-Piston
4	UP07146	1	S/P	30CC CYLINDER KIT (Includes 5-9)
5	04388B	1	S/P	GASKET-Cylinder
6	06900A	1	/P	GASKET-Heat Dam
7	98766A	1	S/P	GASKET-Carburetor
8	98786C	1	/P	GASKET-Muffler
9	880841	3	S	SCREW, SEMS (12-24 x .750) (Torque Specs 55-65 In/Lbs, 6.2-7.3 Nm, Loctite Required Red 262)
10	880811	4	/P	SCREW, SEMS (10-24 x .910) (Torque Specs 25-30 In/Lbs, 2.8-3.4 Nm, Loctite Required Red 262)
1	UP03122	1		SHORT BLOCK (25CC) (Includes 2nd 2-10)
2	UP00768	1	S/P	25CC PISTON & ROD (Includes 3)
3	PS01359	1	S/P	RING-Piston
4	UP07145	1	S/P	25CC CYLINDER KIT (Included 5-9)
5	04388B	1	S/P	GASKET-Cylinder
6	06900A	1	/P	GASKET-Heat Dam
7	98766A	1	S/P	GASKET-Carburetor
8	98786C	1	/P	GASKET-Muffler
9	880841	3	S	SCREW, SEMS (12-24 x .750)
10	880811	4	/P	SCREW, SEMS (10-24 x .910)
11	A00858	1	/P	CRANKCASE COVER (Includes 12)
12	08661	1	/P/F	GASKET-Crankcase Cover
13	82541	2	/P	SCREW-Plastite (#10 X 1/2") (Torque Specs 30-40 In/Lbs, 3.4-4.5 Nm)
14	A00254A	1	/P	WIRE GUARD KIT (Includes 15 & 16)
15	88049	2	/P	SCREW-Hex Sems (10-24 X 1/2") (Torque Specs 40-50 In/Lbs, 4.5-5.6 Nm)
16	81208	2	/P	NUT (10-24)

ST385i String Trimmer UT-15173
Ignition - Rotor - Starter - Clutch

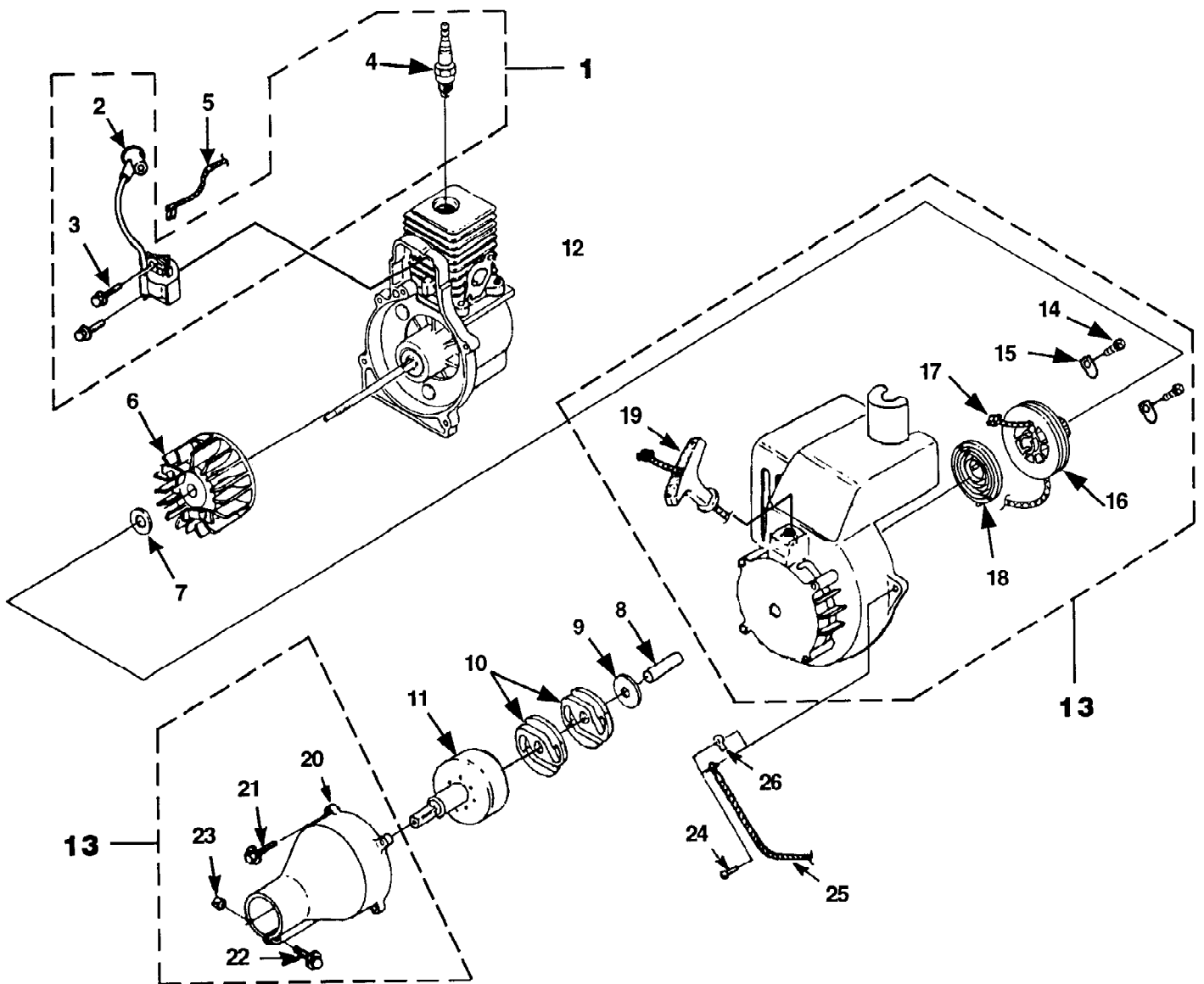

ST385i String Trimmer UT-15173
Ignition - Rotor - Starter - Clutch

Page 6 of 10

Ref #	Part Number	Qty	S/P/F	Description
1	A04446	1	S	IGNITION KIT (Includes 2-4)
2	A33055	1	/P	TERMINAL & COVER
3	82540	2	/P	SCREW-Taptite (8-32 X 1") (Torque Specs 30-40 In/Lbs, 3.4-4.5 Nm, Loctite Required Blue 242)
4	79252	1	S	SPARK PLUG (Torque Specs 120-180 In/Lbs, 13.6-20.3 Nm)
5	A00681	1		LEAD-Electrical
6	UP03009	1		ROTOR KIT (Includes 7 & 8)
7	95479A	1	/P	WASHER-Flat
8	PS035661	1	/P	SPACER
9	98929A	1	S/P	WASHER-Flat
10	00242	2	/P	CLUTCH (ST385i)
		3		CLUTCH (HBC-30i, HBC-30Bi)
11	A03485B	1	S	CONNECTOR & DRUM (HBC-30i, HBC-30Bi)
11	A02727	1	S	CONNECTOR & DRUM (ST385i)
12		1		SHORT BLOCK (See Engine Internal ill. and parts list)
13	A04638C	1	/P	COMPLETE STARTER ASSEMBLY (Includes 14-23)
14	82541	2	/P	SCREW-Plastite (#10-1/2") (Torque Specs 30-40 In/Lbs, 3.4-4.5 Nm)
15	98791	2	/P	BRACKET-Retaining
16	98770A	1	/P	PULLEY-Starter
17	9789902	1	S/P	ROPE-Starter (42")
18	A98773A	1	S/P	SPRING & CONTAINER
19	PS00179	1	/P	GRIP-Starter
20	A02396A	1	/P	TUBE ADAPTER (Includes 21-23)
21	88052	4	/P	SCREW-hex Hd. (10-24 X 7/8") (Torque Specs 30-40 In/Lbs, 3.4-4.5 Nm)
22	96624	1	/P	SCREW-Sems Hex Hd. (10-24 X 1 1/8")
23	81208	1	/P	NUT (10-24) (Torque Specs 40-50 In/Lbs, 4.5-5.6 Nm)
24	82538	4	/P	SCREW-Taptite (10-24 X 3/4") (Torque Specs 55-60 In/Lbs, 6.2-6.8 Nm)
25	A98919A	1	S	LEAD-Ground
26	02851	1	/P	TERMINAL-Male

ST385i String Trimmer UT-15173
Muffler - Air Cleaner

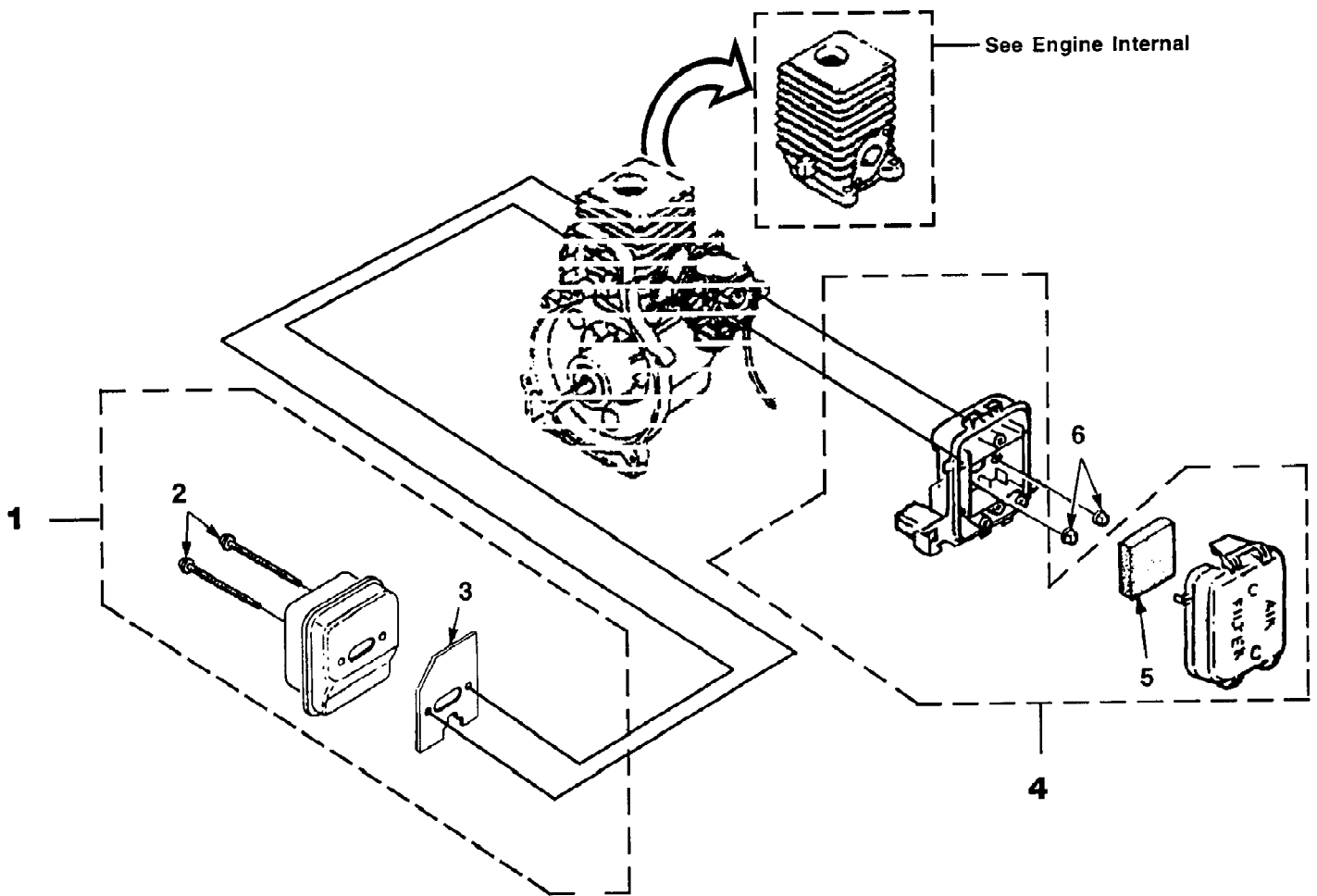

ST385i String Trimmer UT-15173
Muffler - Air Cleaner

Page 8 of 10

Ref #	Part Number	Qty	S/P/F	Description
1	A07315	1	S	MUFFLER COMPLETE (Includes 2 & 3)
2	88060	2	S/P	SCREW-Sems Hex (10-24 X 2 1/2") (Torque Specs 40-50 In/Lbs, 4.5-5.6 Nm)
3	98786C	1	/P/F	GASKET-Muffler
4	A04707A	1	/P	AIR FILTER KIT (Includes 5)
5	98760	1	/P	FILTER-AIR
6	81208	2	/P	NUT-Hex (10-24) (Torque Specs 40-50 In/Lbs, 4.5-5.6 Nm)

ST385i String Trimmer UT-15173

Straight Shaft Boom - Handle - Throttle - Stringhead - Grass Deflector

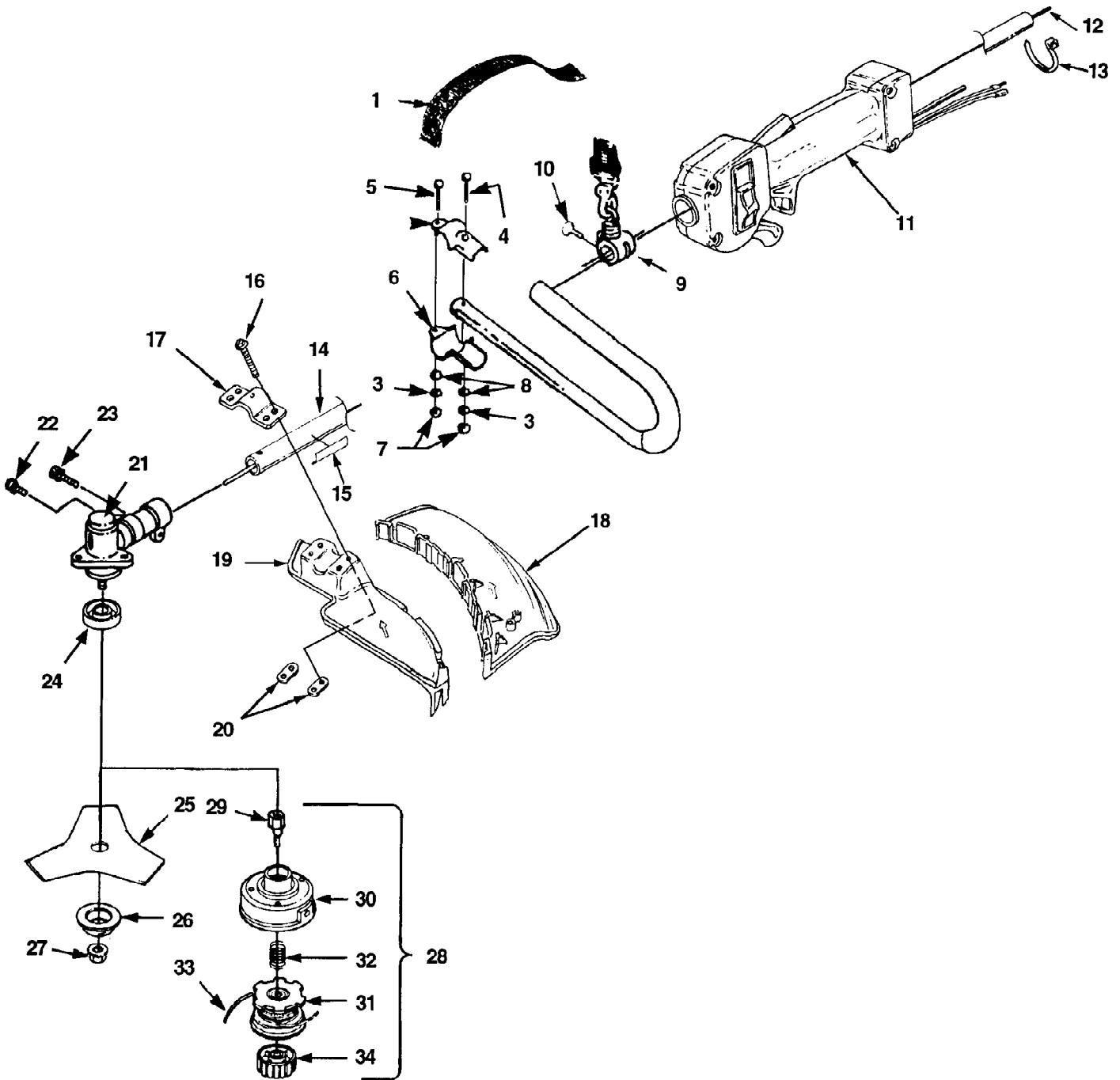

ST385i String Trimmer UT-15173

Page 10 of 10

Straight Shaft Boom - Handle - Throttle - Stringhead - Grass Deflector

Ref #	Part Number	Qty	S/P/F	Description
1	UP00108	1	S	HARNESS w/Connector
?2	A07159	1	S	J-HANDLE BAR KIT (Includes 3-8)
3	83009	2	/P	Washer-Lock
4	82278	1	/P	SCREW-Hex Hd. (1/4-20 X 1/2") (Torque Specs 75-85 In/Lbs, 8.5-9.6 Nm)
5	82496	1	/P	SCREW-Hex Hd. (1/4-20 X 1") (Torque Specs 75-85 In/Lbs, 8.5-9.6 Nm)
6	00422	1	S/P	CLAMP-Handle Bar
7	81242	2	/P	NUT-Hex (1/4-20)
8	84004	2	/P	WASHER- Flat
9	A94442	1	/P	BRACKET-Hanger (Includes 10)
10	82260	1	/P	SCREW-Thumb (10-24 X 1/2")
11	A08899	1		THROTTLE & SWITCH w/Lead
12	98832	1	/P	SHAFT-Drive
13	PS46840	1		CABLE-Tie
14	A03800A	1	S	HOUSING-Drive Shaft (Includes 15)
15	02985	1	S	DECAL-Warning
16	825551	4	S	SCREW-Mach. Truss Hd. (10-24 X .750) (Torque Specs 40-50 In/Lbs, 4.5-5.6 Nm)
17	08619	1	S	CLAMP
18	A08152	1	S	STRING SHIELD
19	08573	1	/P	BLADE GUARD
20	A08139	1	/P	MOUNTING PLATE
21	A03888	1	S	GEAR HEAD
22	88049	1	/P	SCREW-Sems Hex Hd. (10-24 X 1/2") (Torque Specs 40-50 In/Lbs, 4.5-5.6 Nm)
23	82586	1	/P	SCREW-Cap Socket Hd. (1/4-20 x 7/8") (Torque Specs 55-65 In/Lbs, 7.2-7.3 Nm)
24	041681A	1	S	WASHER-Flange
25	D98717C	1	S/P	BLADE-Tri-Arc
26	04409	1	/P	WASHER-Flange
27	04277	1	/P	NUT-Hex (L.H.)
28	DA03174A	1	S/P	STRINGHEAD COMPLETE (Includes 29-34)
29	9855141	1	/P	CONNECTOR-Drive
30	A98231A	1	S/P	HOUSING & EYELET (Dual Line)
31	UP00147	1	S/P	SPOOL & STRING (Dual Line) (Includes 32)
32	B06713	1	S/P	SPRING-Compression
33	D06514	1	S/P	LINE-Replacement (.095" Dia.) (285')
34	A97910A	1	S/P	RETAINER-Spool (L.H.) (Red)