

i4550b Chain Saw UT-10862
 Carburetor - Muffler - Air Filter

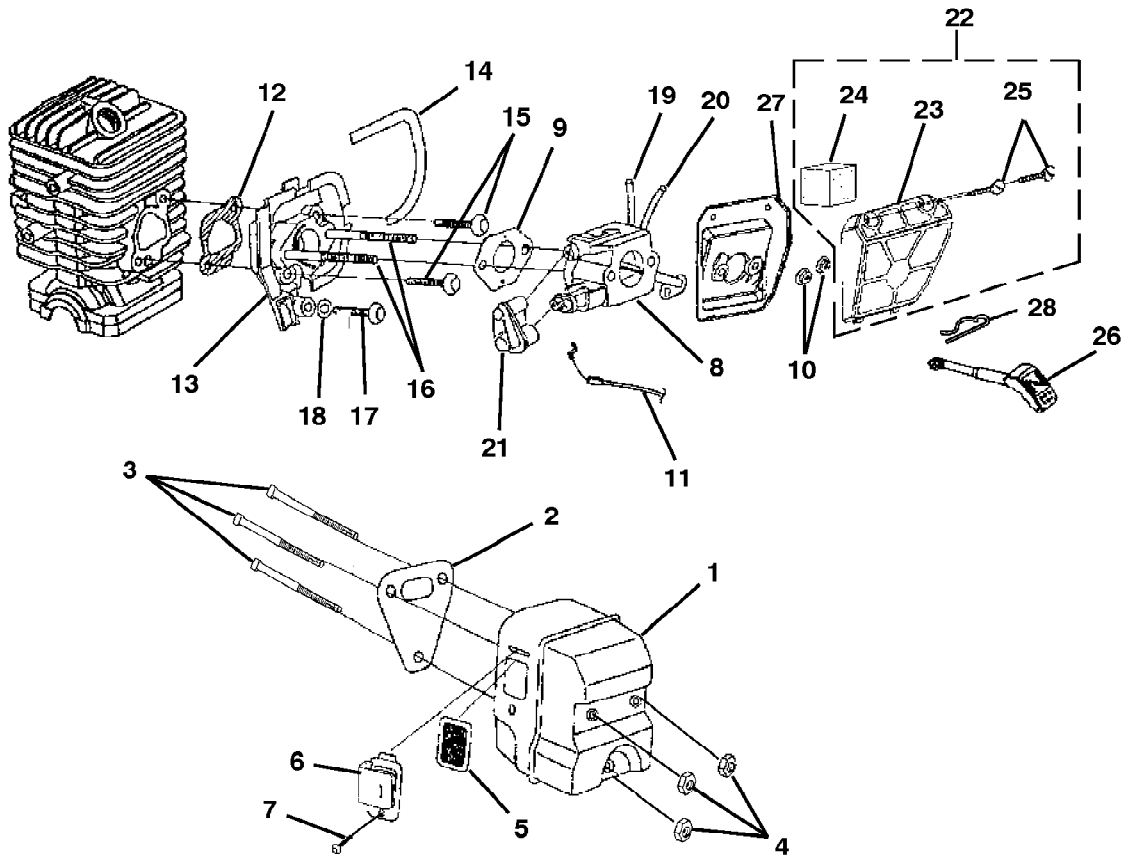

Item No.	Torque Specs		Required Loctite
	In/Lbs	Nm	
4	50-60	5.6-6.7	
10	30-40	3.4-4.5	
15	45-55	5.0-6.2	
17	30-40	3.4-4.5	
25	15-20	1.7-2.3	

i4550b Chain Saw UT-10862
Carburetor - Muffler - Air Filter

Page 2 of 12

Ref #	Part Number	Qty	S/P/F	Description
1	UP00126A	1	/P	Muffler Kit (45cc) Includes items 2-7
2	06839	1	S/P	Muffler Gasket
3	PS04525	3	S/P	Screw-Square Hd.
4	81206	3	S/P	Nut-Locking Hex (10-32)
5	07394	1	/P	Screen, Spark
6	PS00087	1	/P	Deflector, Muffler (45cc)
7	95922	1	/P	Screw
8	UP00499	1		Carburetor Assy (Int'l 45cc) Includes items 9-10
9	98339	1	S/P	Carburetor Gasket
10	07589	2	/P	Flange Nut (10-24)
11	A07596B	1	S/P	Throttle Cable
12	06840A	1	/P	Gasket, Heat Dam
13	04916	1	/P	Heat Dam
14	06873	1	/P	Seal, Heat Dam
15	82539	2	S/P	Screw, Truss Hd. Taptite (10-24 x 7/8")
16	06852	2	/P	Screw, Carburetor
17	82541	1	/P	Screw, Thread Form (10-14 x 1/2")
18	12789	1	/P	Washer, Retaining
19	0745434	1	/P	Fuel Line (Tank to Carburetor 8 1/2")
20	0745416	1	/P	Fuel Line (Carburetor to Purge Bulb 4")
21	04907	1	/P	Carburetor Grommet
22	UP06753A	1	/P	Air Filter Kit Includes items 23-25
23	04938	1	/P	Air Filter Cover
24	PS05070	1	/P	Pre Filter (In engine housing)
25	82617	2	/P	Screw-Slotted Pan Hd. (8-16 x 5/8")
26	PS03969	1	S/P	Rod, Choke
27	04937	1	/P	Air Filter Plate
28	08939	1	/P	Spring Clip (Choke Rod)

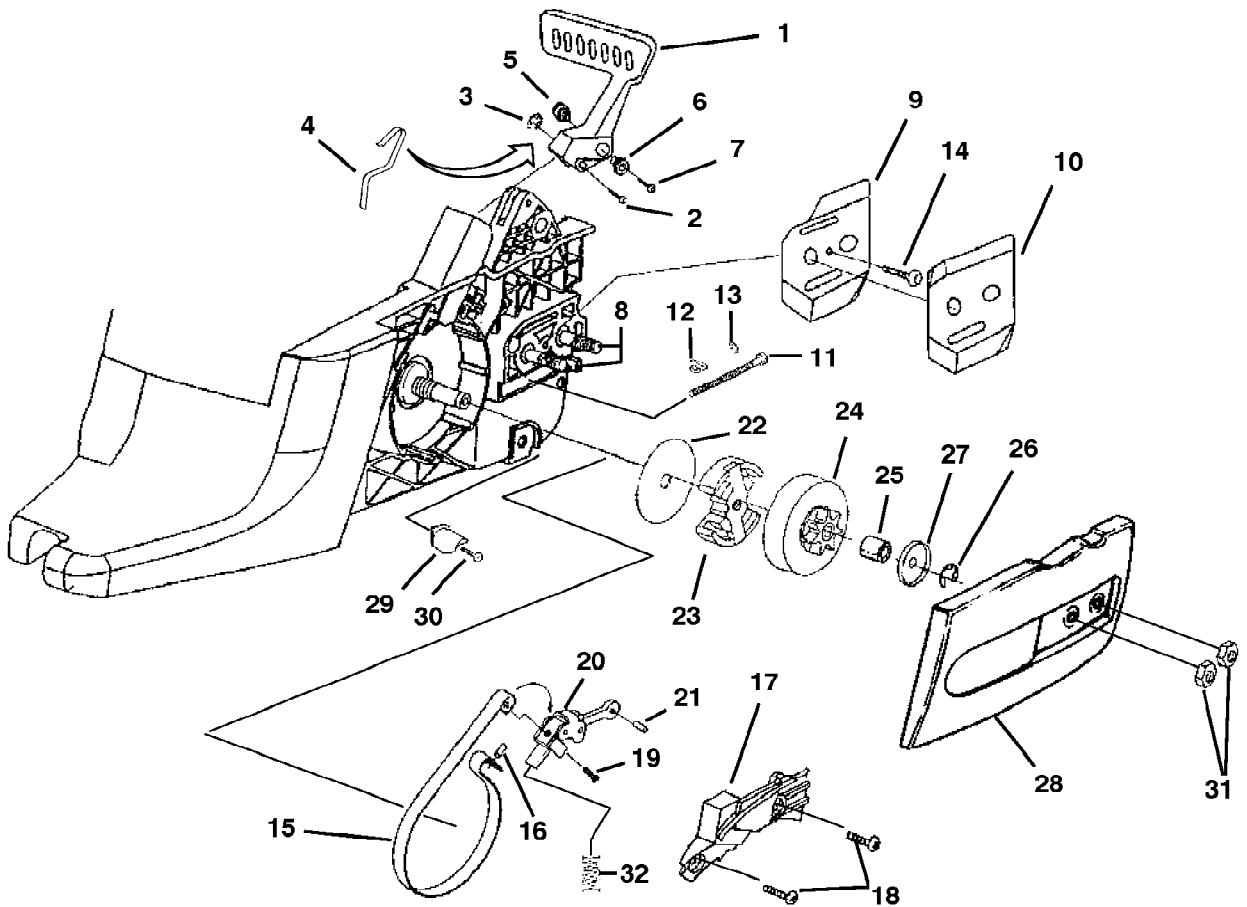

Item No.	Torque Specs		Required Loctite
	In/Lbs	Nm	
7	25-35	2.8-3.9	
14	8-18	9-2.0	
18	10-20	1.1-2.3	
19	20-30	2.3-3.4	
23	130-180	14.7-20.3	
30	30-50	3.4-5.6	
31	Hand Tight		

i4550b Chain Saw UT-10862
Clutch - Chain Brake - Drive Case Cover

Page 4 of 12

Ref #	Part Number	Qty	S/P/F	Description
1	UP06568A	1	S/P	Hand Guard Kit Includes items 2-3
2	07580	1	S/P	Hand Guard Actuating Pin
3	69599	1	/P	Retaining Ring
4	07613	1	/P	Spring, Handguard
5	07393	1	S/P	Pivot, L.H.
6	07392	1	S/P	Pivot, R.H.
7	82624	1	/P	Screw, Hex Socket Hd. (8-32 x 5/8")
8	PS04881	2	/P	Guide Bar Bolt
	UP06966A	1	/P	Guide Bar Adjusting Kit Includes items 9-13
9	07404A	1	/P	Plate, Guide Bar
10	07405A	1	/P	Plate, Guide Bar
11	06844	1	/P	Screw, Guide Bar Adjusting
12	06842	1	/P	Pin, Guide Bar Adjusting
13	69599	1	/P	Ring, Retaining
14	82513	1	/P	Screw, Thread Form (6-19 x 1/2")
15	UP06373A	1	/P	Chain Brake Kit Includes items 16-19
16	06672	1	S/P	Pin, Roll
17	06843A	1	/P	Cover, Chain Brake
18	82513	2	/P	Screw, Pan Hd. (6-19 x 1/2")
19	82623	1	S/P	Screw, Pan Hd. (8-16 x .320)
20	984897001	1	/P	Chain Brake Link
21	95395A	1	/P	Pin, Roll
22	04940	1	/P	Thrust Washer
23	UP06727A	1	S/P	Clutch & Hardware
24	A06867	1	S	Sprocket, Drum (.325 Pitch) Includes items 25-26
25	PS04669	1	/P	Bearing, Needle
26	08981	1	/P	Ring, Retaining
27	04939A	1	/P	Washer, Cupped
28	UP06975A	1	/P	Drive Case Cover Includes items 29-30
29	UP05634A	1	/P	Stop, Chain
30	82541	1	/P	Screw, Thread Form (10-14 x 1/2")
31	81196	2	S/P	Nut, Hex
32	984679001	1	/P	Spring, Compression

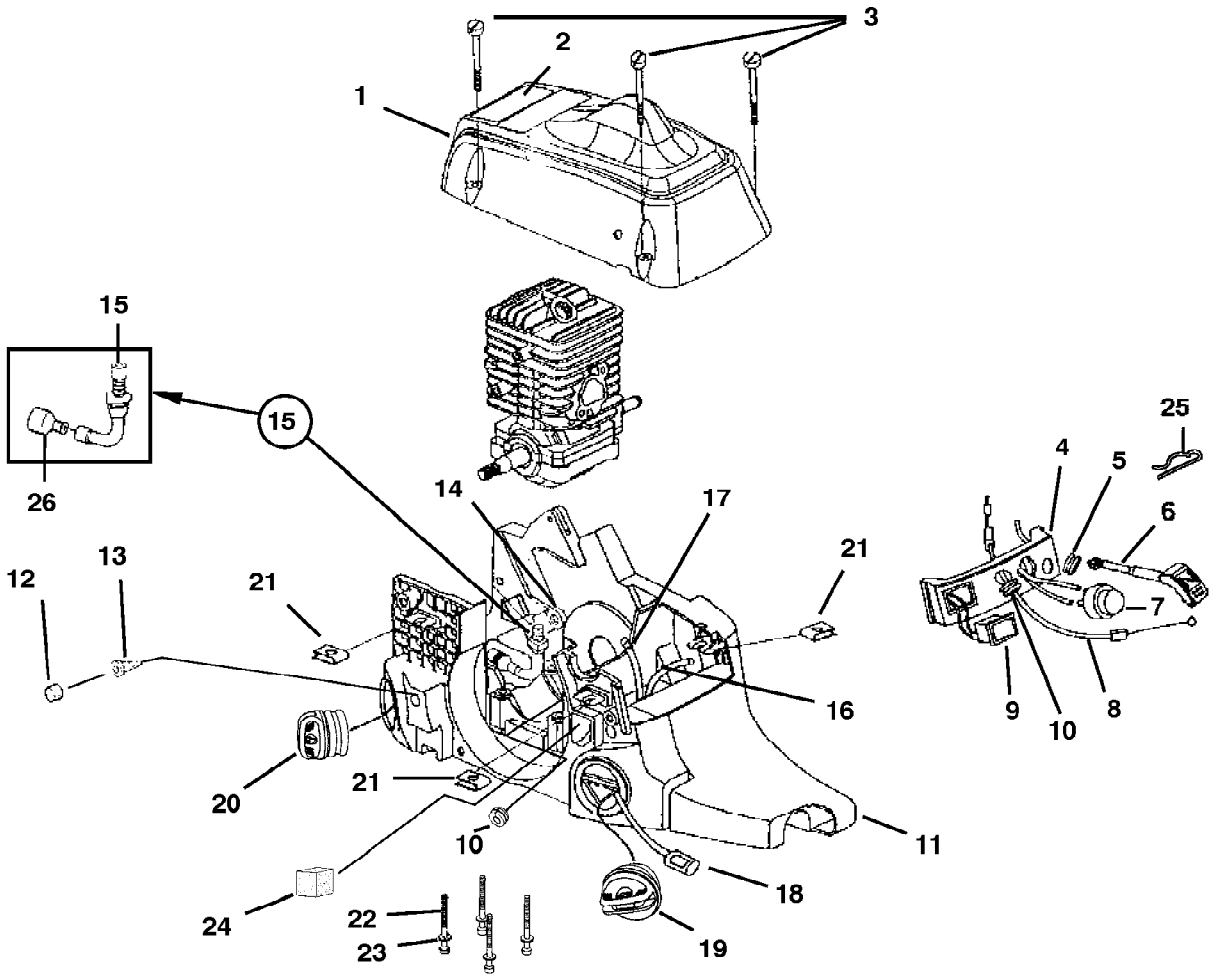

Item No.	Torque Specs		Required Loctite
	In/Lbs	Nm	
3	15-25	1.7-2.8	
22	65-76	7.3-8.5	

i4550b Chain Saw UT-10862
Engine Housing - Fuel Tank - Oil Tank

Page 6 of 12

Ref #	Part Number	Qty	S/P/F	Description
1	A08692A	1	S/P	Cylinder Cover Kit Includes items 2-3
2	PS06324	1	S/P	Safety Decal
3	07597	3	S/P	Screw-Slotted Pan Hd.
4	PS03503	1	/P	Control Panel
5	64862	1	/P	Grommet
6	PS03969	1	S/P	Rod, Choke
7	01183	1	/P	Bulb, Air Purge
8	A07596B	1	S/P	Throttle Cable
9	PS02369	1	/P	Switch, Rocker
10	07587	2	/P	Grommet - Split
11	UP06754A	1	/P	Engine Housing Includes items 12-20
12	07403	2	S/P	Element, Filter (Bronze)
13	03134	2	S/P	Duck Bill Valve
14	06841	1	/P	Oil Outlet Grommet
15	PA01037	1	/P	Oil Intake Tube
16	0745422	1	/P	Rubber Tubing (5 1/2")
17	0745434	1	/P	Rubber Tubing (8 1/2")
18	PS03380	1	/P	Fuel Filter
19	DA07590	1	S	Fuel Cap w/ Retainer
20	DA07591	1		Oil Cap w/ Retainer
	A68593	1		Oil Filter (Not Shown)
	PS04881	1	/P	Guide Bar Bolt (Not Shown)
21	07598	3	/P	Speed Nut ("U-Type")
22	82527	4	S/P	Screw, Cap-Socket Hd. (10-24 x 2")
23	84008	4	S/P	Washer
24	PS05070	1	/P	Pre Filter
25	08939	1	/P	Spring Clip (Choke Rod)
26	A68593	1		Oil Filter

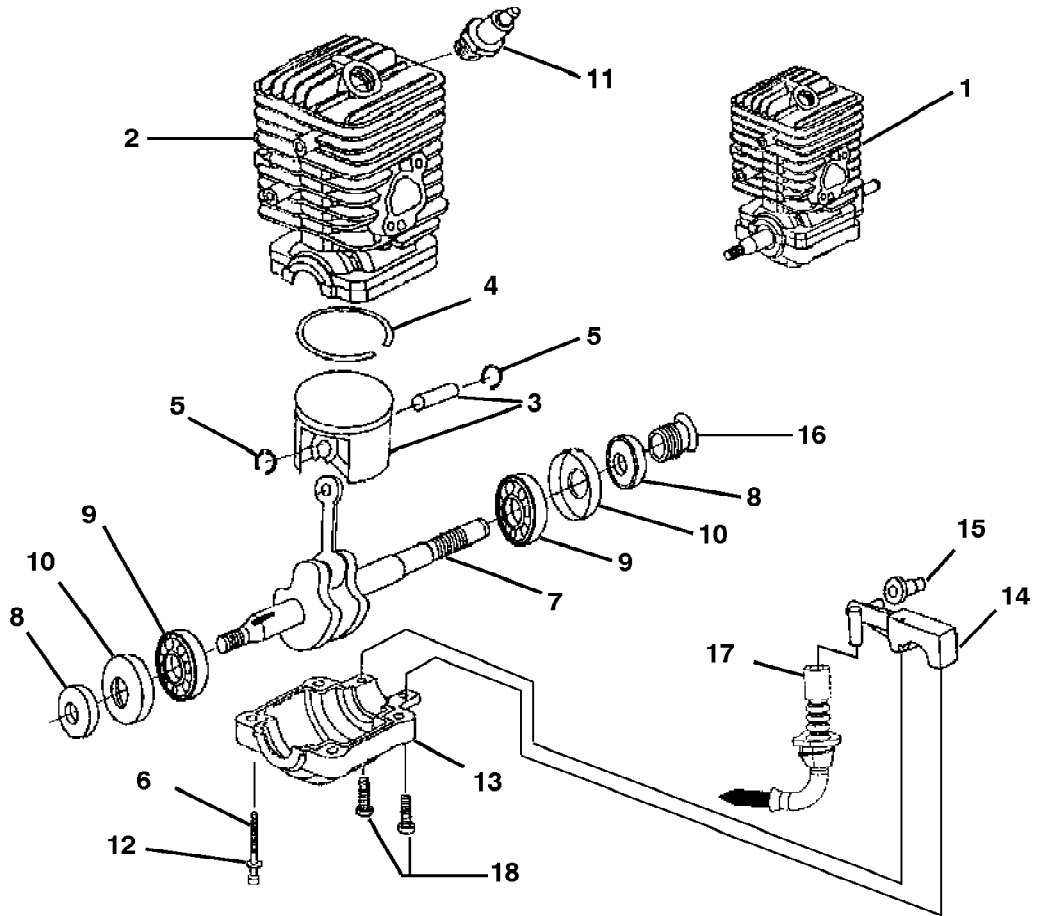

Item No.	Torque Specs		Required Loctite
	In/Lbs	Nm	
6	65-75	7.3-8.5	262 Red
11	120-180	13.6-20.3	
18	15-20	1.7-2.3	

i4550b Chain Saw UT-10862
Engine Internal - Oil Pump

Page 8 of 12

Ref #	Part Number	Qty	S/P/F	Description
1	UP04166A	1	/P	Short Block, Complete (45cc) Includes Items 2-10
2	UP00129A	1	/P	Cylinder Kit (45cc) Includes Items 2
	06839	1	S/P	Gasket, Muffler (Not Shown)
	06840A	1	/P	Gasket, Heat Dam (Not Shown)
	98339	1	S/P	Gasket, Carburetor (Not Shown)
3	UP00130A	1	/P	Piston & Pin (45cc) Includes Items 4-5
4	09082	1	/P	Piston Ring (45cc)
5	64813	2	/P	Ring, Retaining
6	82527	4	S/P	Screw, Cap-Socket Hd. (10-24 x 2")
7	UP04165A	1	/P	Crankshaft & Rod Assy (45cc) Includes Items 8-10
8	04920	2	S/P	Shaft Seal
9	08838	2	/P	Ball Bearing
10	04919	2	S/P	Rubber Case
11	PS02227	1	S/P	Spark Plug
12	84008	4	S/P	Washer
13	09097	1	/P	Lower Crankcase (45cc)
14	UP06602	1	/P	Oil Pump Kit Includes Items 15-17
15	06841	1	/P	Grommet, Oil Outlet
16	06847	1	S/P	Left Hand Worm
17	PA01037	1	/P	Oil Intake Tube w/Filter
18	82546	2	S/P	Screw, T.F. (8-16 x 5/8")

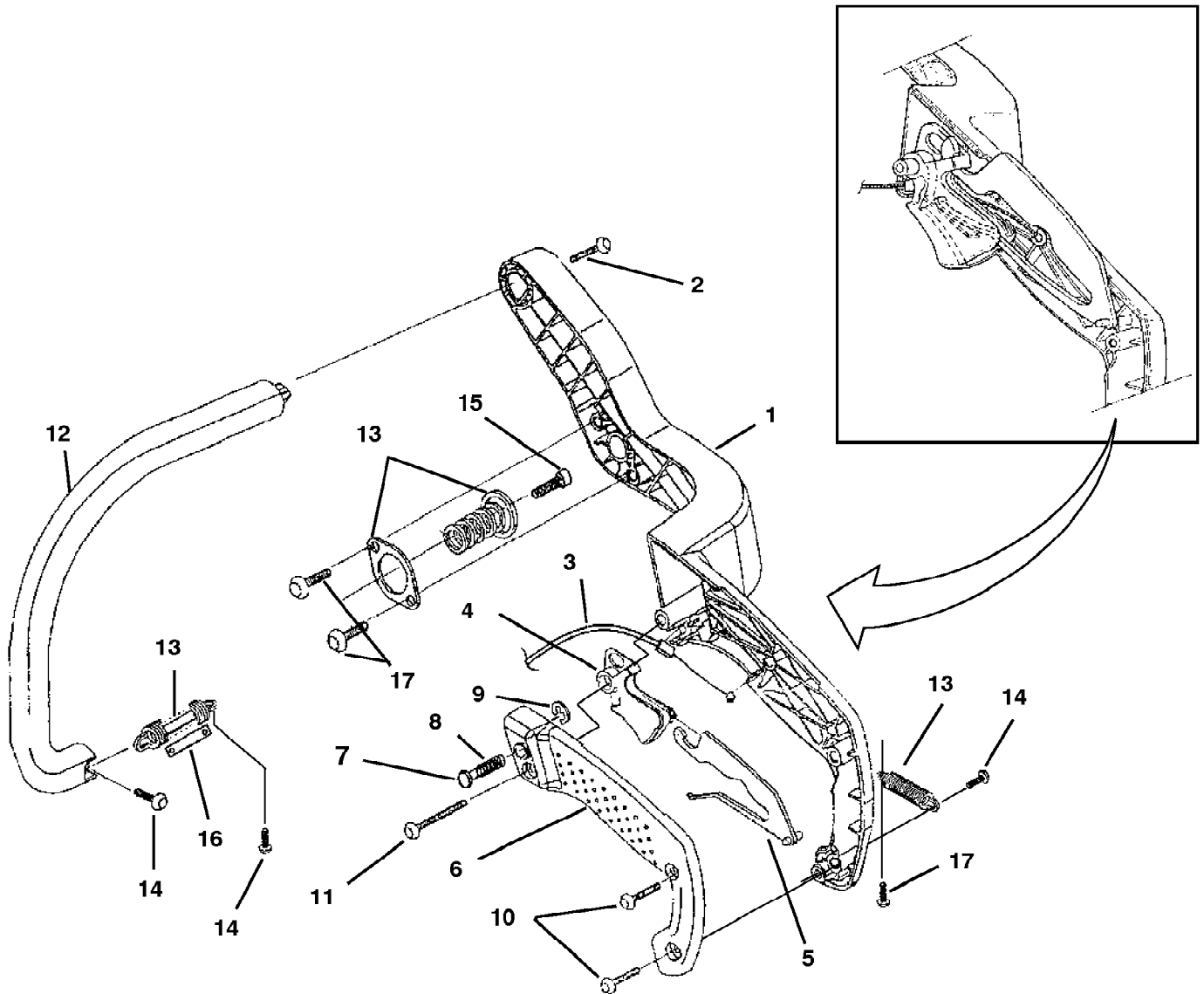

Item No.	Torque Specs		Required Loctite
	In/Lbs	Nm	
2	40-50	4.5-5.6	
10	30-40	3.4-4.5	
11	30-40	3.4-4.5	
14	30-40	3.4-4.5	
15	40-50	4.5-5.6	
17	30-40	3.4-4.5	

i4550b Chain Saw UT-10862
Handles

Page 10 of 12

Ref #	Part Number	Qty	S/P/F	Description
1	UP06977A	1	/P	Rear Handle Kit Includes items 2-11
2	82615	1	/P	Screw-Pan Hd. (12-14 x 1 1/2")
3	A07596B	1	S/P	Throttle Cable
4	984354001	1	S/P	Trigger, Throttle
5	PS03966	1	/P	Throttle Lock Out
6	A08683A	1	/P	Handle Cover Kit Includes items 7-10
7	PS03971	1	/P	Throttle Lock Pin
8	08898	1	/P	Spring, Compression
9	58409	1	/P	Ring, Retainer
10	82563	2	/P	Screw, Thread Form (10-14 x 3/4")
11	82622	1	/P	Screw, Thread Form (10-14 x 1 3/8")
12	UP06973A	1	/P	Front Handle Kit
	82615	1	/P	Screw-Pan Hd. (12-14 x 1 1/2") (See No. 2 above)
13	UP08007A	1	/P	Isolator Kit Includes items 14-16
14	82621	3	/P	Screw, Truss Hd. (10-14 x 5/8")
15	82597	1	S/P	Screw, Truss Hd. (10-24 x 5/8")
16	01812A	1	/P	Limitter, Isolator
17	82541	3	/P	Screw, Thread Form (10-14 x 1/2")

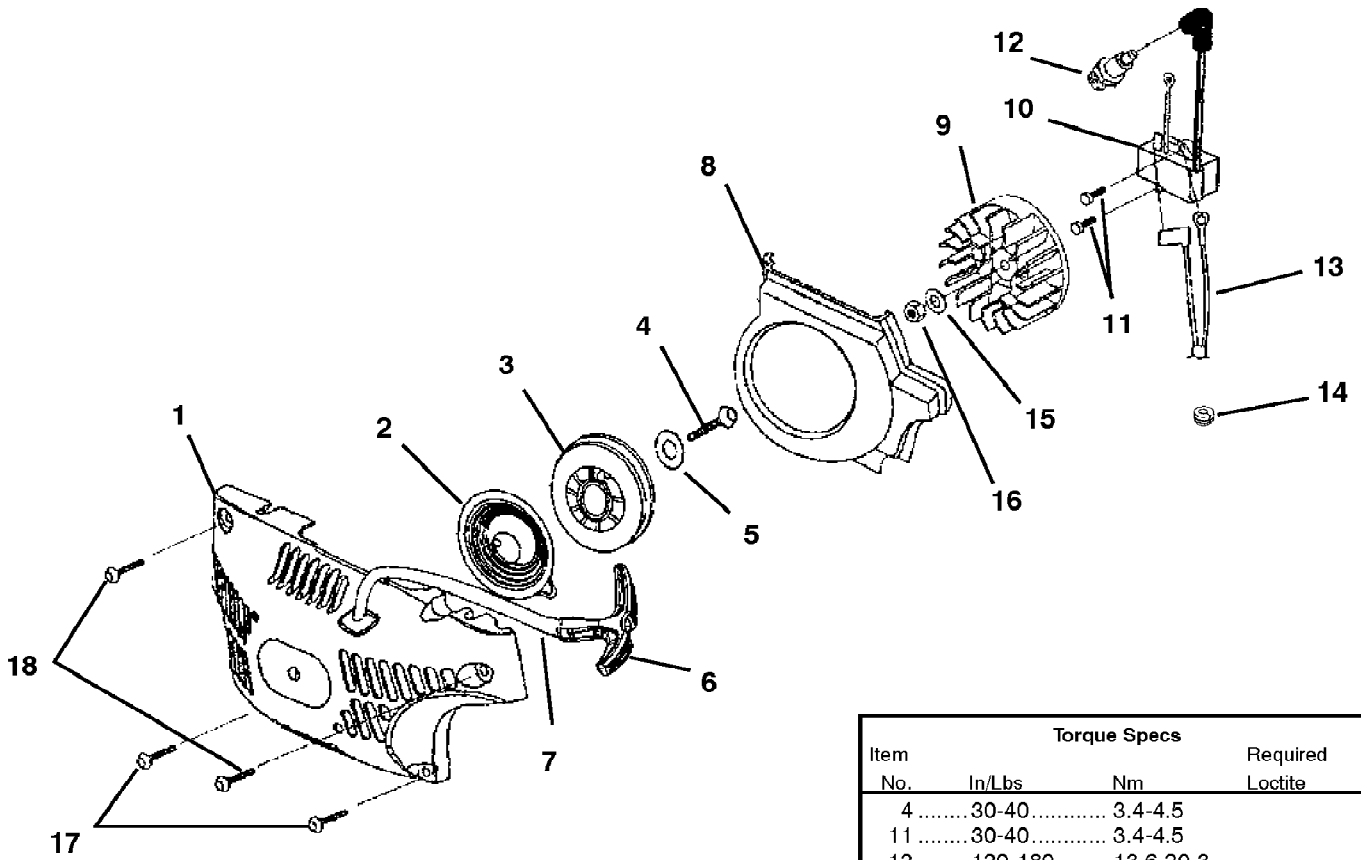

Item No.	Torque Specs		Required Loctite
	In/Lbs	Nm	
4	30-40	3.4-4.5	
11	30-40	3.4-4.5	
12	120-180	13.6-20.3	
16	100-150	11.3-16.9	
17	30-40	3.4-4.5	
18	30-40	3.4-4.5	

i4550b Chain Saw UT-10862
Starter - Ignition

Page 12 of 12

Ref #	Part Number	Qty	S/P/F	Description
1	UP06749A	1	S/P	Starter Kit Includes Items 2-7
2	A97908	1	/P	Spring & Container
3	PS03117	1	/P	Pulley, Starter
4	82621	1	/P	Screw, Thread Form (10-14 x 5/8")
5	94062	1	/P	Washer, Retaining
6	PS03480	1	S	Grip, Starter
7	9789901	1	/P	Rope, Starter 46"
8	06876	1	/P	Baffle, Fan Housing
9	UP05850A	1	S	Rotor & Starter Pawl
10	UP05851A	1	/P	Ignition Kit Includes Item 11
11	82575	2	S/P	Screw, Thread Form (8-32 x 5/8")
12	PS02227	1	S/P	Spark Plug
13	A07602A	1	/P	Ignition Switch Harness
14	07587	1	/P	Grommet, Wire Harness (Split)
15	PS84065	1	S/P	Washer, Flat
16	81229A	1	/P	Nut, Jam
17	82620	2	/P	Screw, Truss Hd. (10-14 x 7/8")
18	82621	2	/P	Screw, Truss Hd. (10-14 x 5/8")