

HOMELITE 18 in. 46cc CHAIN SAW - MODEL NUMBERS UT10552

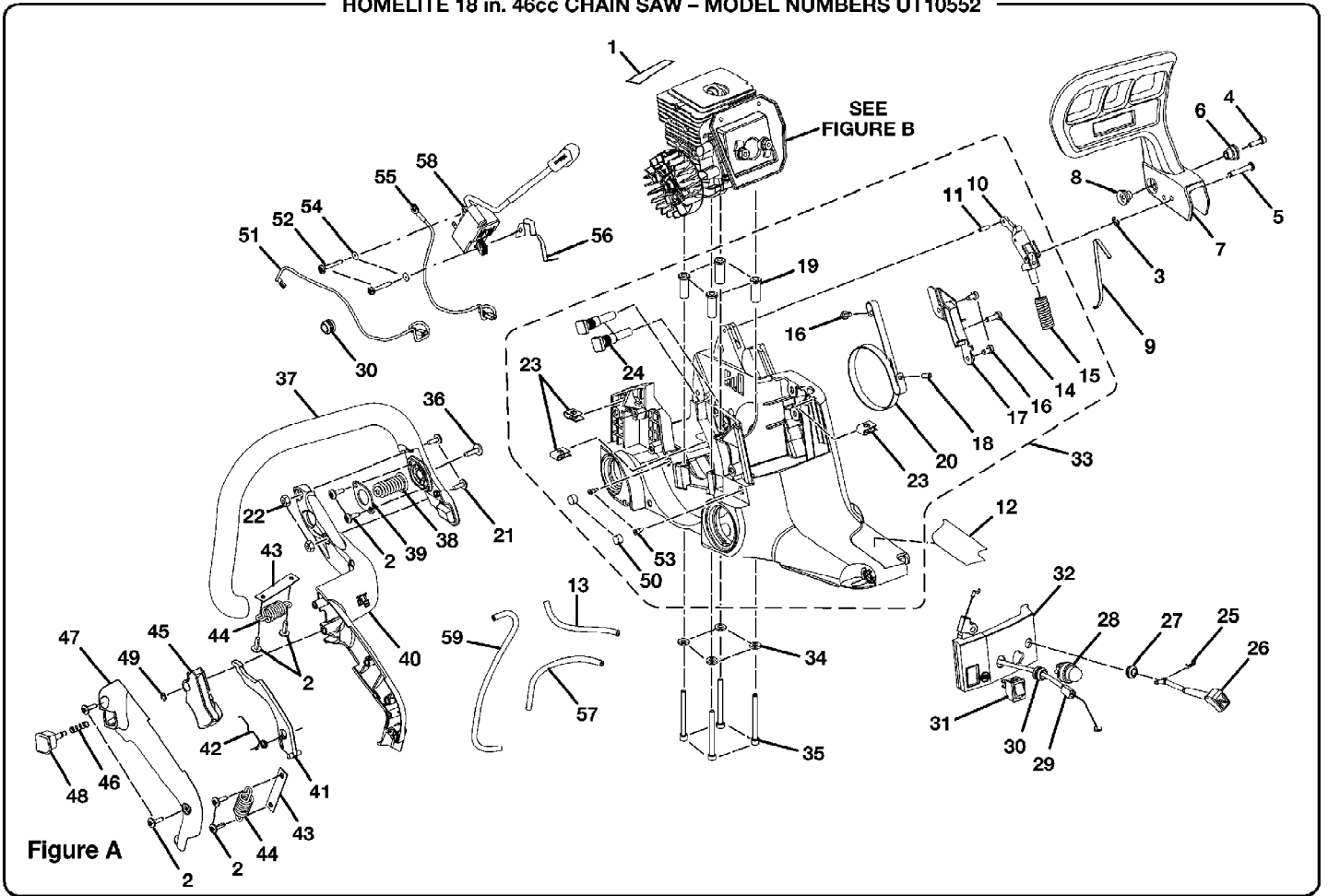

SUPER 2 Chain Saw UT-10552
Figure A

Page 2 of 8

Ref #	Part Number	Qty	S/P/F	Description
1	901358001	1		Heat Reflector Tape
2	660632001	8	S	Screw (10-14 X 5/8 in. Torx Pan Hd.) Purchase locally
3	671075001	1	S	Retaining Ring
4	660635001	1	S	Screw (8-32 X 5/8 in. Hex Soc. Hd.) Purchase locally
5	620442001	1		Handguard Lever Pin
6	671096001	1	/P	Pivot (Right Hand)
7	518278001	1		Handguard
8	671097001	1	/P	Pivot (Left Hand)
9	638024001	1	/P	Spring
10	300954002	1		Chain Brake Link Assembly
11	671099001	1	S	Roll Pin (Small)
12	940636001	1		On-board Label
13	570247006	1		Rubber Tubing (95 mm)
14	660634002	1		Screw (8-16 X 17 mm) Purchase locally
15	678113001	1	S	Spring
16	660634001	3	/P	Screw (8-16 X 0.32 Pan Hd.) Purchase locally
17	518305001	1		Brake Band Cover
18	671095001	1	/P	Roll Pin (Big)
19	671087001	4		Spacer Insert
20	631063001	1	S	Chain Brake Band Kit
21	660964001	2		Screw (10-24 X 19.5 mm) Purchase locally
22	678744002	2		Lock Nut (10-24) Purchase locally
23	671077001	3	S	Speed Nut ("U"-type)
24	660628001	2	S	Guide Bar Bolt
25	631034001	1	S	Spring Clip
26	518298001	1		Choke Rod
27	570219001	1		Grommet
28	300780002	1	S	Primer Assembly
29	900885002	1		Throttle Cable
30	570227001	2	S	Split Grommet
31	760338001	1	S	Switch
32	518276001	1		Control Panel
33	308823001	1	S	Chassis Assembly Inc. Key Nos. 10, 11, 14-20, 23, 24, 50 and 53
34	671080001	4	/P	Washer
35	660622001	4	/P	Screw (10-24 X 2 in. Soc. Cap Hd.) Purchase locally
36	660630001	1	/P	Screw (10-24 X 5/8 in. Torx Hd.) Purchase locally
37	518244001	1		Front Handle
38	671100003	1		Upper Isolator Spring
39	631051001	1		Isolator Plate
40	518240001	1		Handle Support
41	518301001	1		Lockout Throttle
42	678037001	1	S	Torsion Spring
43	308776001	2		Isolator Limiter
44	671100002	2		Isolator Spring

SUPER 2 Chain Saw UT-10552
Figure A

Page 3 of 8

Ref #	Part Number	Qty	S/P/F	Description
45	518300001	1		Trigger
46	671073001	1	S	Spring
47	518241001	1		Handle Cover
48	518299001	1		Throttle Lock Pin
49	638177001	1		Retaining Ring
50	671088001	2	/P	Element
51	290709001	1		Lead, Ignition Wire
52	660792001	2		Screw (9-15 x 1 in.) Purchase locally
53	560955001	2	/P	Duck Bill Valve
54	678399001	2		Washer
55	290709002	1		Lead,ground Wire
56	290709003	1		Lead,ground Wire
57	570247007	1		Rubber Tubing (120 mm)
58	300953002	1		Ignition Module
59	570247008	1		Rubber Tubing (222 mm)

SUPER 2 Chain Saw UT-10552
Figure B

Page 5 of 8

Ref #	Part Number	Qty	S/P/F	Description
1	640982004	1		Cylinder
2	678182001	1		Piston Ring
3	671168001	1		Wire Clamp
4	570662001	1		Intake Boot Rubber
5	518490001	1		Carburetor Plate
6	660879001	2		Screw (10-24 x 2-1/4 in.) Purchase locally
7	300945001	1	S	Oil Pump Assembly
8	678183001	2		Retaining Ring
9	570597001	1		Oil Outlet Grommet
10	640975002	1		Piston (46cc)
11	660632001	4	S	Screw (10-14 x 5/8 in. Torx Pan Hd.) Purchase locally
12	518245001	1		Carburetor Spacer
13	T610389001	1	/P	Left Hand Worm
14	570577001	1		Spacer Seal
15	631061001	1	S	Thrust Washer
16	300960003	1	/P	Clutch Assembly
17	308290001	1		Crankshaft Assembly
18	900843001	1	S/P	Carburetor Gasket
19	518312001	1		Carburetor Grommet
20	308370001	1		Carburetor Assembly
21	518360001	1		Air Filter Plate
22	678033001	2	S	Flange Nut (10-24) Purchase locally
23	308291001	1		Oil Intake Tube with Spring
24	308007001	2		Bearing Case with Bearing
25	640957001	1		Crankcase
26	660627001	2	S	Screw (8-32 X 5/8 in. Pan Hd.) Purchase locally
27	678123001	1	/P	Nut (5/16-24) Purchase locally
28	631049001	1	S/P	Flat Washer
29	308631001	1		Rotor Assembly
30	570220001	2	/P	Shaft Seal
31	620392001	1		Piston Pin
32	300984004	1		Short Block Assembly Inc. Key Nos. 1, 2, 8, 10, 17, 24, 25, 30 and 31

SUPER 2 Chain Saw UT-10552
General Assembly

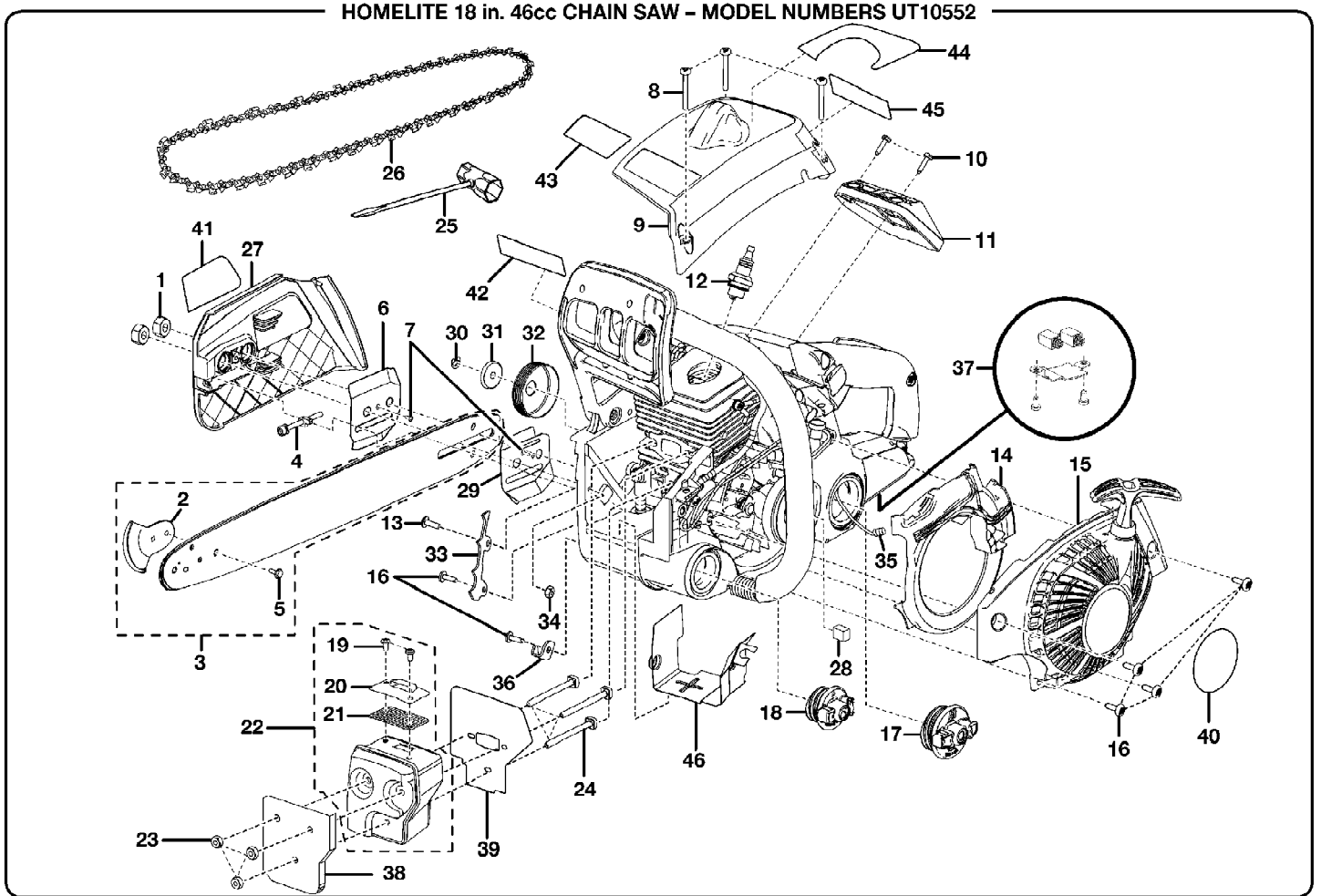

Ref #	Part Number	Qty	S/P/F	Description
1	671076001	2	/P	Guide Bar Nut (5/16-18)
2	308006003	1		SAFE TIP
3	308626001	1		Guide Bar (16 in.) Incl. Key Nos. 2 and 5
4	308116002	1		Guide Bar Adjustment Assembly
5	660640001	1		SAFE-T-TIP (Screw and Washer)
6	638173001	1		Outer Guide Plate
7	660619002	2		Screw (6-19 x 1/2 in. T.F.) Purchase locally
8	660636001	3	/P	Screw (10-16 x 1-1/2 in. Special) Purchase locally
9	518238001	1		Top Cover
10	660617001	2	S	Screw (8-16 x 16 mm Torx T.F.) Purchase locally
11	518306001	1		Air Filter Cover
12	870174001	1	/P	Spark Plug Champion RCJ6Y
13	660868001	1		Screw (10-24 x 5/8 in. Torx Pan Hd.) Purchase locally
14	518283001	1		Baffle
15	308383001	1		Starter Cover Assembly
16	660632001	6	S	Screw (10-14 x 5/8 in. Torx Pan Hd.) Purchase locally
17	308362001	1		Fuel Cap Assembly
18	308363001	1		Oil Cap Assembly
19	660624001	2	S	Screw (8-32 x 5/16 in.) Purchase locally
20	638148001	1		Plate
21	638147001	1		Spark Screen
22	300940005	1		Muffler Assembly Incl. Key Nos. 19-21
23	671079001	3	/P	Lock Nut (10-32) Purchase locally
24	660765001	3		Bolt (10-32 x 63.6 mm Square Hd.) Purchase locally
25	308369001	1		Combination Wrench
26	900920007	1		Chain
27	308364001	1		Chain Cover Assembly
28	900844002	1		Pre-Filter
29	638169001	1		Inner Guide Plate
30	671103001	1	S	E-Ring
31	631060001	1	S	Cupped Washer
32	300958002	1		Sprocket Drum & Bearing Assembly
33	638176001	1		Bumper Spike
34	678744002	1		Lock Nut (10-24) Purchase locally
35	300759003	1	S	Fuel Filter
36	631035001	1	S	Chain Guard
37	120640001	1		Tool Holder Assembly
38	638041002	1		Heat Shield
39	900977003	1		Muffler Gasket
40	940718001	1		Starter Housing Decal
41	940635002	1		Clutch Cover Label
42	940634001	1		Chain Brake Label
43	940661002	1		Warning Label
44	940632001	1		Starting Instruction Decal
45	940964002	1		Icon Warning Label
46	638381001	1		Heat Shield

SUPER 2 Chain Saw UT-10552
General Assembly

Page 8 of 8

Ref #	Part Number	Qty	S/P/F	Description
	580656001	1		Scabbard Not Shown
	983000736	1		Operator's Manual (961027002)
	983000736R	1		Repair Sheet