

No
Diagram
Available

Parts List
Only

LX30 Bandit Chain Saw UT-10716-D
Accessories

Page 2 of 10

Ref #	Part Number	Qty	S/P/F	Description
	A70776B	1	/P	SAFE T TIP (Standard)
	18453	1	/P	GREASE-Multi Purpose
	A70239E	1		KIT-Repair (sprocket nose bar)
	D24814B	1		WRENCH (combination) TOOLS
	PS24823	1	/P	SILASTIC (crankcase sealing) TOOLS
	A24747A	1		PULLER-Magneto Rotor TOOLS
	HT10001O4	1		GUIDE BAR
	H1N7242AH	1		(35-MD50-42) CHAIN
	HT12001O4	1		GUIDE BAR
	H1N7248BH	1		(35-MD50-48) CHAIN
	PT12371O4	1		GUIDE BAR
	H1N7248BH	1		(35-MD50-48) CHAIN
	PT14371O4	1		GUIDE BAR
	H1N7253AH	1	S	(35-MD50-53) CHAIN
	PT16371O4	1		GUIDE BAR
	H1N7259AH	1	S	(35-MD50-53) CHAIN
	GP203225	1		IGNITION TEST SPARK PLUG
	22486	1		SHIM (0.015" AIR GAP)
	2498201	1		T25 TORX DRIVE BIT
	1856601	1	/P	T27 TORX DRIVE BIT

LX30 Bandit Chain Saw UT-10716-D
Engine Housing External

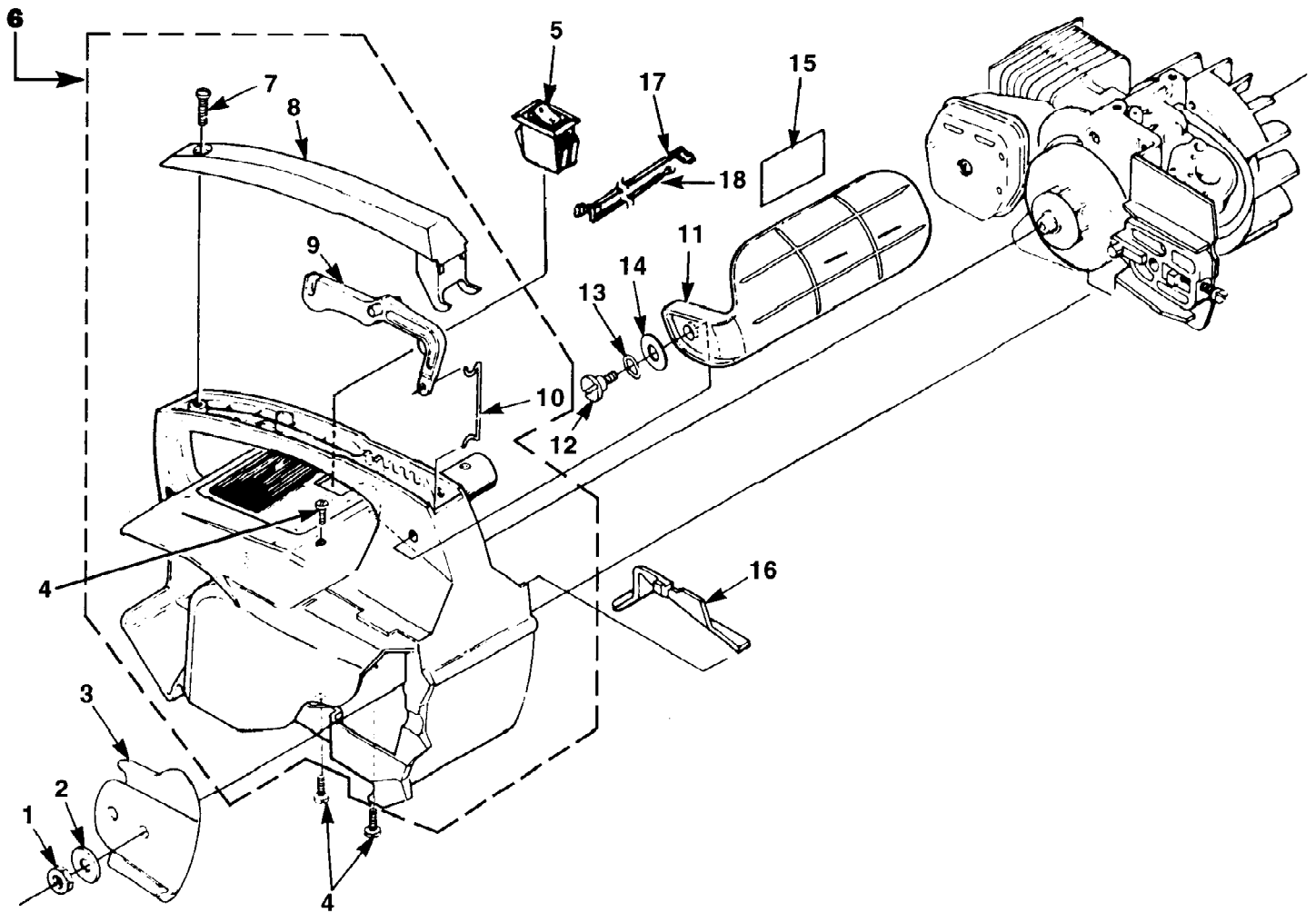

LX30 Bandit Chain Saw UT-10716-D
Engine Housing External

Page 4 of 10

Ref #	Part Number	Qty	S/P/F	Description
1	810652	1	S	NUT - Guide Bar (Torque Specs: Hand Tight)
2	69309A	1	/P	WASHER - Flat
3	04440	1		PLATE - Guide Bar
4	82538	4	/P	SCREW - Pan Hd. (10-24 X 3/4") (Torque Specs: 55-65 In/Lbs, 6.3-7.5 Nm)
5	02497	1	S/P	SWITCH - Rocker
6	A07551	1	/P	ENGINE HOUSING KIT
7	82312	1	/P	SCREW - Pan Hd. (#10 X 5/8") (Torque Specs: 15-20 In/Lbs, 1.7-2.3 Nm)
8	69872A	1		COVER - Handle
9	69874D	1	/P	TRIGGER
10	00138	1		ROD - Throttle
11	A70796C	1	S	HANDGUARD
12	95714	1	S	SCREW - Shoulder (#10 X .560) (Torque Specs: 40-50 In/Lbs, 4.6-5.7 Nm)
13	95694	1		WASHER - Curved Spring
14	96102	1		WASHER - Flat
15	02661	1		DECAL - Handguard
16	69263	1		COVER - Air Filter
17	A02484	1		LEAD - Ring Term.
18	A02482	1	S	LEAD - Double Flag

LX30 Bandit Chain Saw UT-10716-D
 Engine Housing Internal

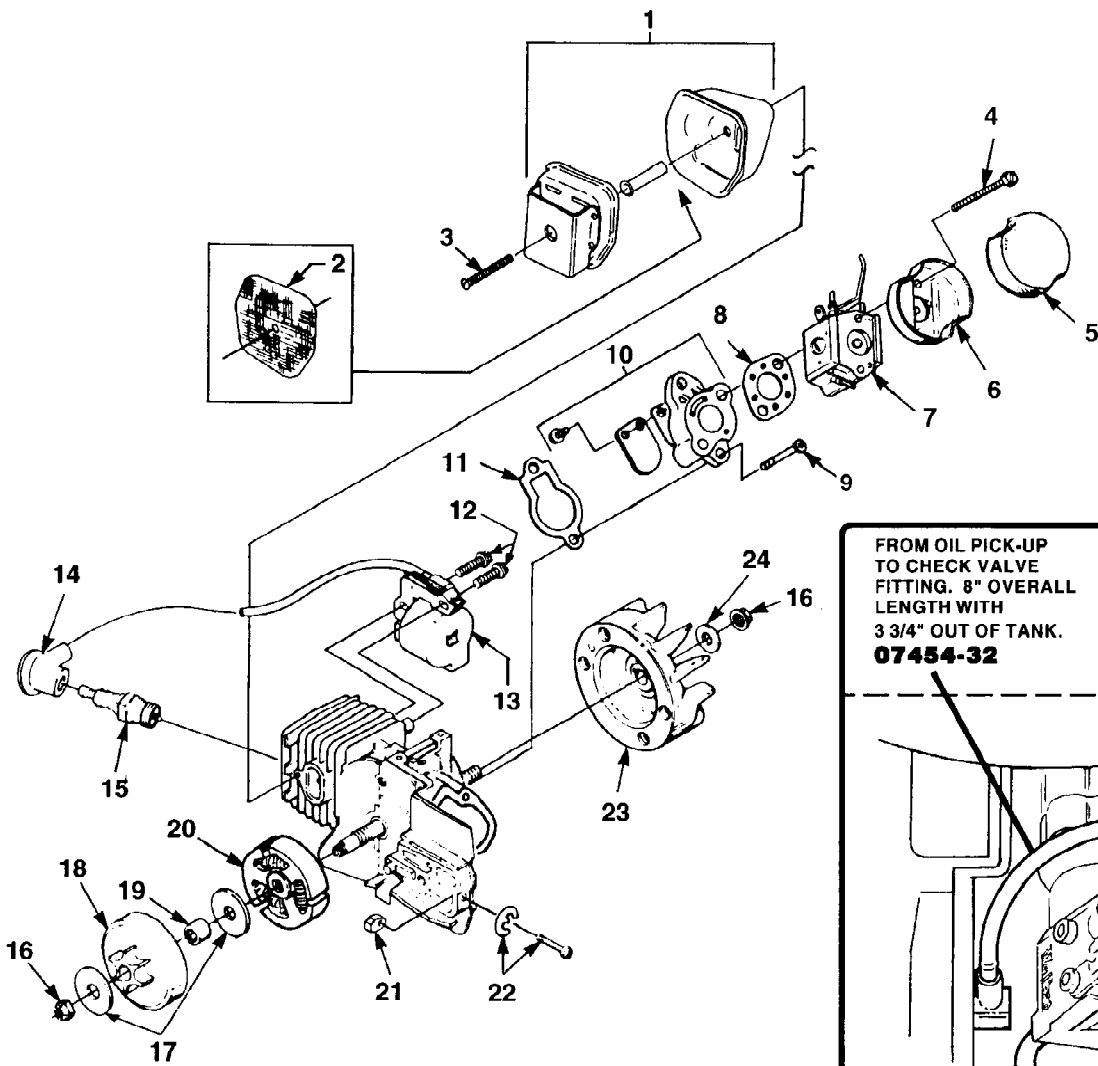

<p>FROM OIL PICK-UP TO CHECK VALVE FITTING. 8" OVERALL LENGTH WITH 3 3/4" OUT OF TANK. 07454-32</p>	<p>PRESSURE PULSE LINE FROM CARBURETOR BRASS ELBOW TO DUCK BILL IN OIL TANK. 2 3/4" LONG. 07454-20</p>
<p>FUEL INLET LINE FROM PICK-UP TO FITTING ON BOTTOM OF CARBURETOR. 5 1/2" LONG OVERALL WITH 1 3/4" OUT OF TANK. 07454-28</p>	

Ref #	Part Number	Qty	S/P/F	Description
1	A06374	1	/P	MUFFLER - Complete
2	93991A	1	S	SCREEN - Spark Arrestor
3	93460	1	/P	SCREW - Sems (10-24 X 1 7/8") (Torque Specs: 50-60 In/Lbs, 5.7-6.9 Nm)
4	00167	2	/P	SCREW - Thd. Form. (#8 X 1.65) (Torque Specs: 35-45 In/Lbs, 4.0-5.2 Nm)
5	69141	1	S	FILTER - Air
6	69148	1		CUP - Filter
7	UP00750	1	/P	CARBURETOR KIT
8	02488	1	S	GASKET - Carburetor
9	82537	2	/P	SCREW - Thread Form. (#10-24 X 7/8") (Torque Specs: 65-75 IN/Lbs, 7.5-8.6 Nm)
10	A02153	1	/P	HEAT DAM & REED
11	02453	1	/P	GASKET - Heat Dam
12	82540	2	/P	SCREW - Thread Form. (8-32 X 1") (Torque Specs: 30-40 In/Lbs, 3.4-4.6 Nm)
13	94711CS	1	/P	MODULE - Ignition
14	A33055	1	/P	TERMINAL
15	96169S	1	S	SPARK PLUG (Torque Specs: 120-180 In/Lbs, 13.8-20.7 Nm)
	79252	1	S	SPARK PLUG (Int'l) (UT-10716-B)
16	81229A	2	/P	NUT - Cone Lock (5/16-24)
17	95299	2	/P	WASHER - Thrust
18	A95653E	1	/P	SPROCKET & DRUM
19	70277	1	S	BEARING
20	A97921	3	S	CLUTCH KIT
21	692542	1	/P	PIN - Guide Bar Adjusting
22	A00440	1	/P	SCREW & E RING KIT
23	A04158S	1	S	ROTOR & STARTER PAWLS
24	84065	1	S	WASHER - (5/16")
0745432	0745432	1		Line
0745420	0745420	1		Pressure Pulse Line
0745428	0745428	1	S	Fuel Inlet Line

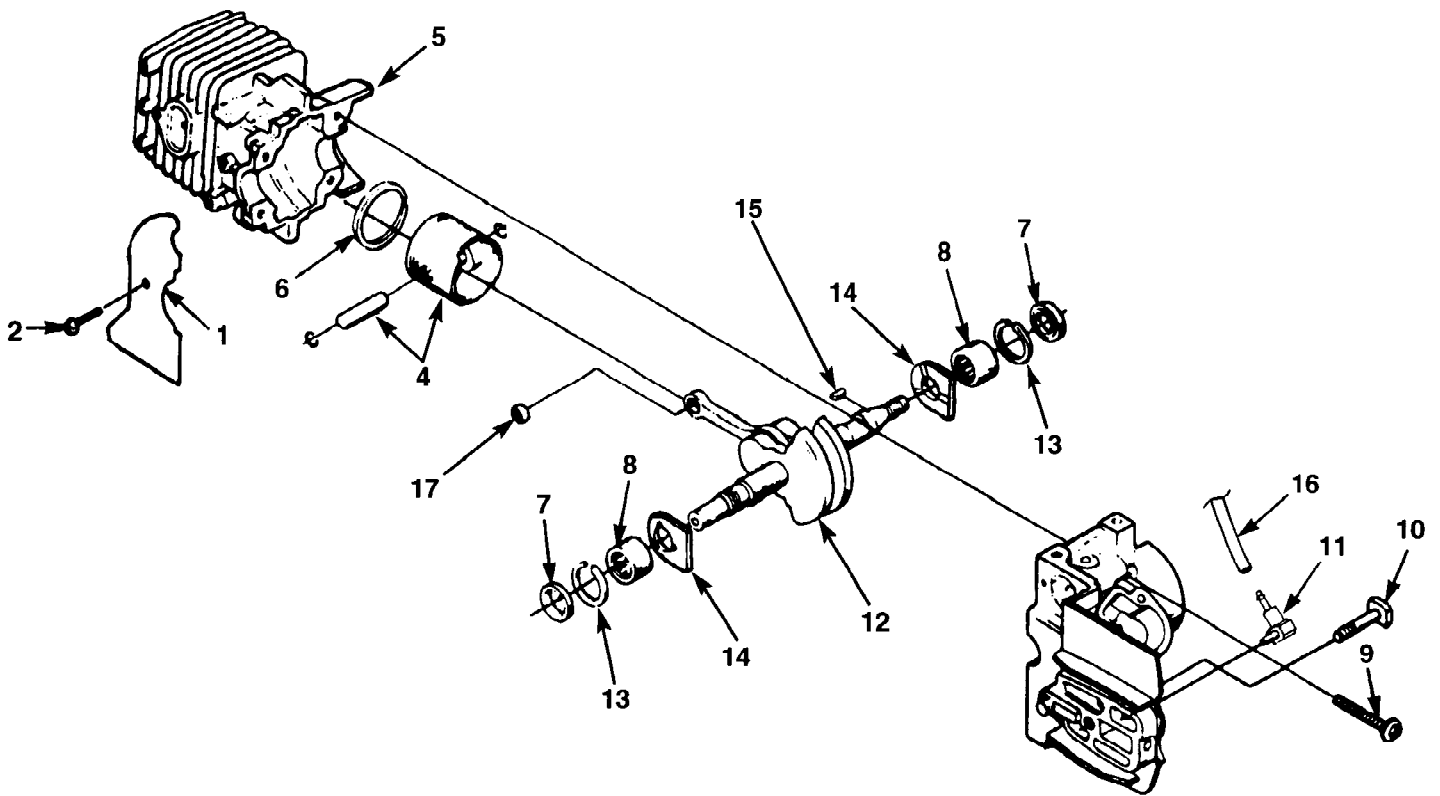

LX30 Bandit Chain Saw UT-10716-D
Engine Internal

Page 8 of 10

Ref #	Part Number	Qty	S/P/F	Description
1	02639	1	/P	SAW DUST SHIELD
2	93932	1		SCREW- Tapping (06-32 x 5/16") (Torque Specs: 18-24 In/Lbs, 2.0-2.8 Nm)
?3	A001321A	1	/P	SHORT BLOCK
	UP00068	1	S	SHORT BLOCK (After S/N HR0010001)
4	A04330	1	/P	PISTON & PIN ASSY.
5	024855	1	/P	CYLINDER
	UP00069	1	S	CYLINDER (After S/N HR0010001)
6	93165	1		RING - Piston
7	07025	2	S	SEAL - Shaft
8	12530	2		BEARING - Needle
9	82567	4		SCREW - Torx Pan Hd. (10-24 x 1 1/8") (Torque Specs: 65-75 In/Lbs, 7.5-8.6 Nm)
10	69195	1	/P	BOLT - Guide Bar
11	07510	1		VALVE - Check
12	A97611A	1	S	CRANKSHAFT - Rod and Bearing
13	69407	2	S	SPACER
14	03962	2		WASHER- Thrust
15	69250	1	/P	KEY-Woodruff
16	0745432	1		TUBING - Rubber (Oil Line) (8")
17	02035	1	/P	BEARING - Wrist Pin

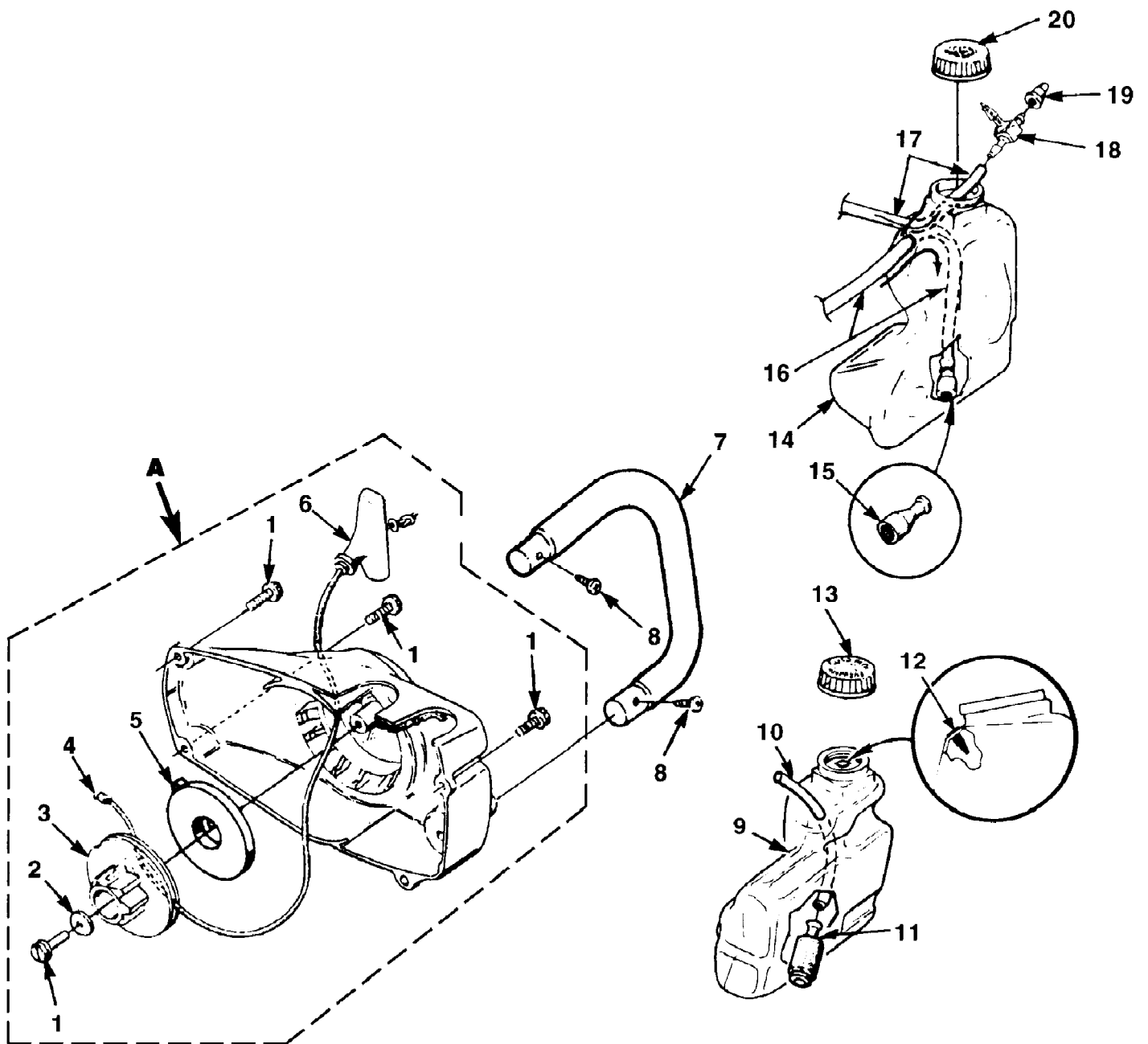

LX30 Bandit Chain Saw UT-10716-D
Starter Housing - Fuel Tank

Page 10 of 10

Ref #	Part Number	Qty	S/P/F	Description
A	A06268A	1	/P	STARTER ASSY., Complete
1	82563	5	/P	SCREW - Torx (#10 X 3/4") (Torque Specs: 30-50 In/Lbs, 3.4-5.8 Nm)
2	94062	1	/P	WASHER - Retaining (#10)
3	97768B	1	S	PULLEY - Starter
4	9789901	1	/P	ROPE - Starter (46")
	98052A	1	/P	ROPE - Starter (250 Ft. Reel)
5	A97908	1	/P	SPRING & CONTAINER
6	02264	1	S	GRIP - Starter
7	A07633	1		HANDLE BAR
8	94065	2		SCREW - Pan Plastite (#10-16 X 3/4") (Torque Specs: 15-20 In/Lbs, 1.7-2.3 Nm)
9	A00174	1		FUEL TANK
10	0745428	1	S	TUBING - Rubber (7")
11	49422	1	S	FILTER - Fuel
12	98819	1	/P	VALVE - Duck Bill
13	A97359A	1	S	FUELCAP
14	A07552	1	/P	OIL TANK
15	A68593	1		FINDER - Oil
16	0745432	1		TUBING - Rubber (8")
17	0745420	1		TUBING - Rubber (5")
18	A07507	1		FITTING - Vent
19	96841	1	S	VALVE - Check
20	A97359A	1	S	OIL CAP