

330 Chain Saw UT-10540
Chain Brake and Chain Stop

Page 2 of 11

Ref #	Part Number	Qty	S/P/F	Description
1	80983	3	S	SCREW- (8-32 x 1/2)
2	70705	1		STOP- Chain
3	88048	1	S	SCREW- (10-24 x 3/8)
4	70632	1	/P	WASHER- Flat
5	A95409A	1		GUARD- hand
6	80672	1	S	SCREW- Pan hd
7	95411	1		BRACKET
8	80821	1	/P	SCREW (12 24 x 1/2)
9	95283	1		BAND- Brake
10	81192	1	S	NUT- Hex (3/8-24)
11	95376	1		INSERT- Chain brake
12	95410	1		WASHER- Spring
13	95284A	1		SPRING- Torsion
14	95287	1		DETENT- Brake lever
15	95295	1		SPACER- Flanged
16	82254	2	S	SCREW- Mach pan hd. (8-32 x 1/2)
17	95286	1		LINK- Chain brake
18	95494	1		BUSHING
19	953941	1	/P	SHIELD- Chain brake
	95838	1		BUMPER- Spike (not shown)
	960621	1		CARBURETOR SHIELD (not shown)

330 Chain Saw UT-10540
Engine Internals

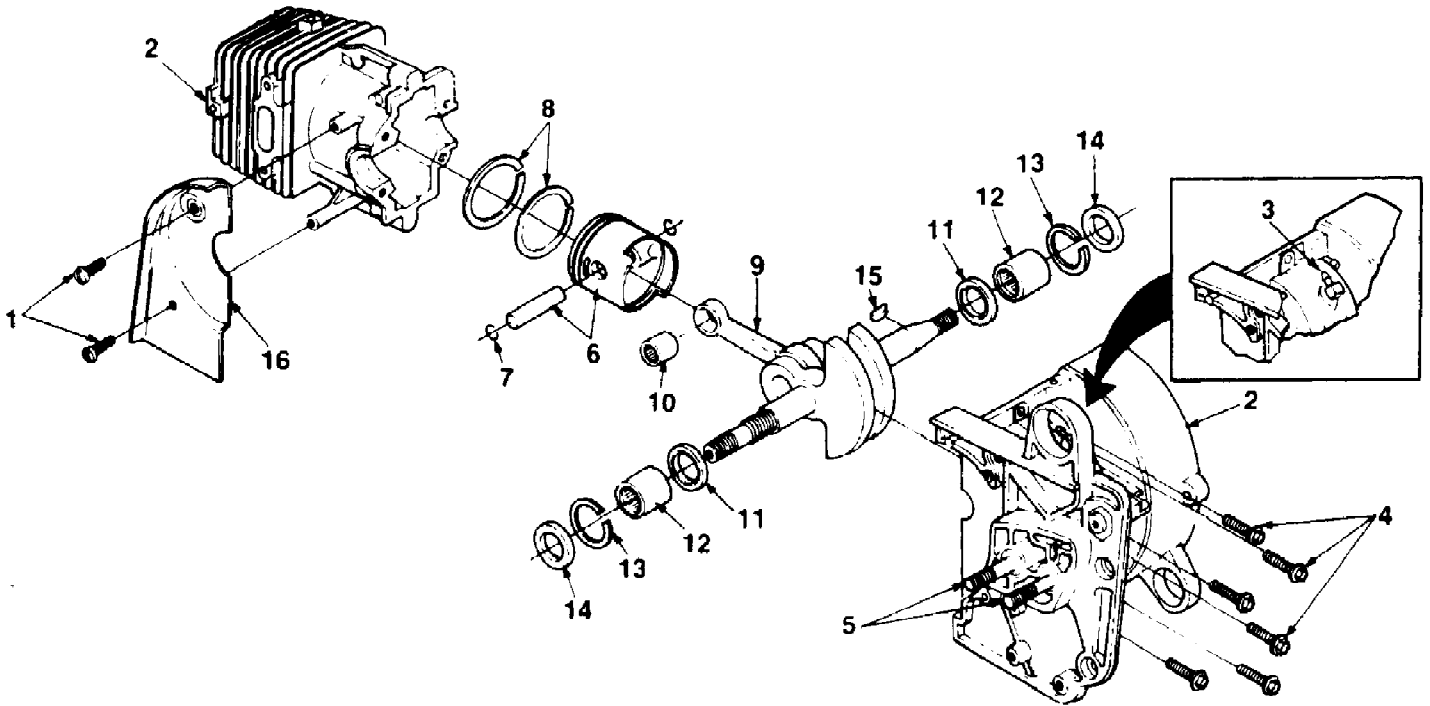

330 Chain Saw UT-10540
Engine Internals

Page 4 of 11

Ref #	Part Number	Qty	S/P/F	Description
1	88049	2	/P	SCREW- Sems hex (10-24 x 1/2)
2	A95884A	1		CRANKCASE & CYLINDER
3	70204	1	/P	FITTING- Tube
4	88053	6	S	SCREW- (10-24 x 1)
5	93859	2		BOLT- Guide bar
	94392	1		FITTING- Tube (L) not shown
	94619	1		FITTING- Tube (Not shown)
6	A95882A	1		PISTON
7	64813	2	/P	RING- Retaining
8	96510	2	S	PISTON RING
9	A96418B	1		CRANKSHAFT
10	93369	1		BEARING- Rod
11	94860	2	F	WASHER- Thrust
12	93846	2		BEARING- Needle
13	93819	2		RING- Retaining
14	93858	2	S	SEAL- Crankshaft
15	75078	1		KEY- Woodruff
16	93832	1		SHIELD- Sawdust

330 Chain Saw UT-10540
Handles, Carburetor Chamber & Starter

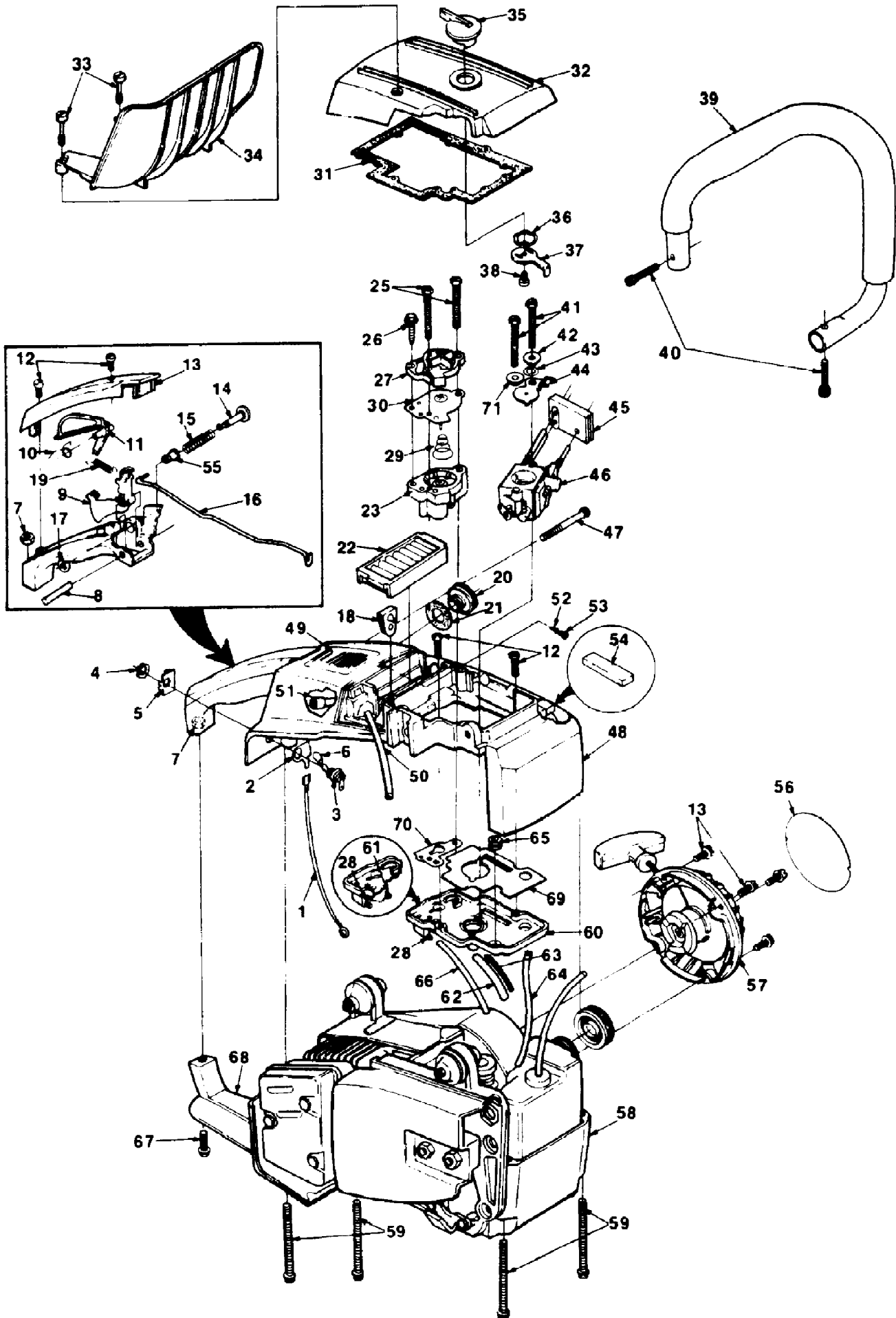

330 Chain Saw UT-10540
Handles, Carburetor Chamber & Starter

Page 6 of 11

Ref #	Part Number	Qty	S/P/F	Description
1	A95933A	1		LEAD- Electrical
2	95874	1		CONTACT- Ground
3	A576503A	1	S	SWITCH- Grounding
4	72084A1	1	S	NUT- Switch
5	12793A	1	S	PLATE- Ignition (Run-Stop)
6	69092	1		SLEEVE- Grounding switch
7	81208	1	/P	NUT- Locking hex (10-24)
8	93517	1		PIN- Groove
9	93842	1	/P	TRIGGER- Throttle
10	94379	1		SPRING- Torsional
11	93843	1		THROTTLE- Interlock
12	80983	8	S	SCREW- Hex hd. (8-32 x 1/2)
13	93822	1		HANDLE- Cover
14		1		PIN- Throttle lock
15	95020	1	S	SPRING- Compression
16	94377A	1	/P	ROD- Throttle
17	58409	1	/P	RING- Retaining
18	94376	1		GROMMET
19	95976A	1		SPRING- Extension
20	A95207	1		CAP- Oil
21	94390	1	S	GASKET
22	94387B	1	/P	FILTER ELEMENT- Air
23	A95049	1		PUMP Oil
25	82224	2		SCREW- Hex hd. (8-32 x 2)
26	82380	1		SCREW- Thd. forming (8-16 x 5/8)
27	94395	1		COVER- Oil pump
28	94619	1		FITTING- Tube
29	94634	1		SPRING- Helicoil
30	A94675	1		DIAPHRAGM & PLUNGER
31	95921	1		GASKET- Air filter cover
32	93828	1		COVER- Air filter
33	93578	2	S	SCREW- Self retaining (330 only)
	95792	2	/P	SCREW- Rd. hd. (10-24) (330SL only)
34	95027	1		GUARD- Hand (330 only)
35	94389	1		BUTTON- Choke
36	94388	1		WASHER- Wave
37	94502	1		LEVER- Choke
38	95922	1	/P	SCREW- Pan taptite (8-32 x 5/16)
39	A93853	1		HANDLE BAR- Flush cut (prior to Lot #C309)
	A938531	1		HANDLE BAR- Flush cut (After Lot #C309)
40	82246	2	/P	SCREW Cap socket hd. (10-24 x 1)
41	82179	2		SCREW- Mach. hex. hd. (10-32 x 1 7/8)
42	94504	1		SPACER- Choke
43	94382	1		WASHER- Wave
44	94503A	1	S	PLATE- Choke
45	94381	1		GROMMET
46	A94380A	1		CARBURETOR (Walbro WT-4) (Alternate source)
	A96421	1		CARBURETOR (Zama C-1S-H3) (Primary source)
47	82377	1		SCREW- Cap socket hd. (10-24 x 1 3/4)
48	A96419A	1		HOUSING- Engine

330 Chain Saw UT-10540
Handles, Carburetor Chamber & Starter

Page 7 of 11

Ref #	Part Number	Qty	S/P/F	Description
49	95633	1		DECAL
50	98688	1	S/P	TUBING (after Lot #C309)
51	A68593	1		FINDER- Oil
52	96841	1	S	VALVE- Duck bill
53	69454	1	/P	FILTER
54	69443	1		FILTER- Fuel tank valve
	95671	1	S	PIN- Throttle lock (after Lot #C309)
	95020	1	S	SPRING- Compression
55	95989	1	S	BUSHING- Flanged
	58409	1	/P	RING- Retaining
56	94386	1		DECAL- Starter housing
57	A94736	1		HOUSING- Starter
58	938302	1		HOUSING- Engine (bottom)
59	88060	4	S/P	SCREW- Hex hd. (10-24 x 2.5000)
60	A94673	1	/P	PLATE- Carburetor chamber
61	94392	1		FITTING- Tube (L)
62	9520108	1	S	TUBING- 2" (pulse line)
63	95216	1		SPRING- Pulse line (inside)
64	9315721	1		TUBING- 5 1/4" (pulse line)
65	64862	1	/P	GROMMET
66	9311212	1	/P	TUBING-3" (Oil Deliver)
	94619	1		FITTING- Tube (see index #28)
67	88051	1		SCREW- Sems hex hd. (10-24 x 3/4)
68	94763	1		BRACE- handle
69	95342	1	/P	GASKET Carburetor
70	94391	1	S	GASKET- Oil pump
	9311226	1		TUBING- 6 1/2" (Oil) (prior to Lot #C309)
71	96894	1		SPACER- Flanged

330 Chain Saw UT-10540
Muffler, Clutch & Ignition

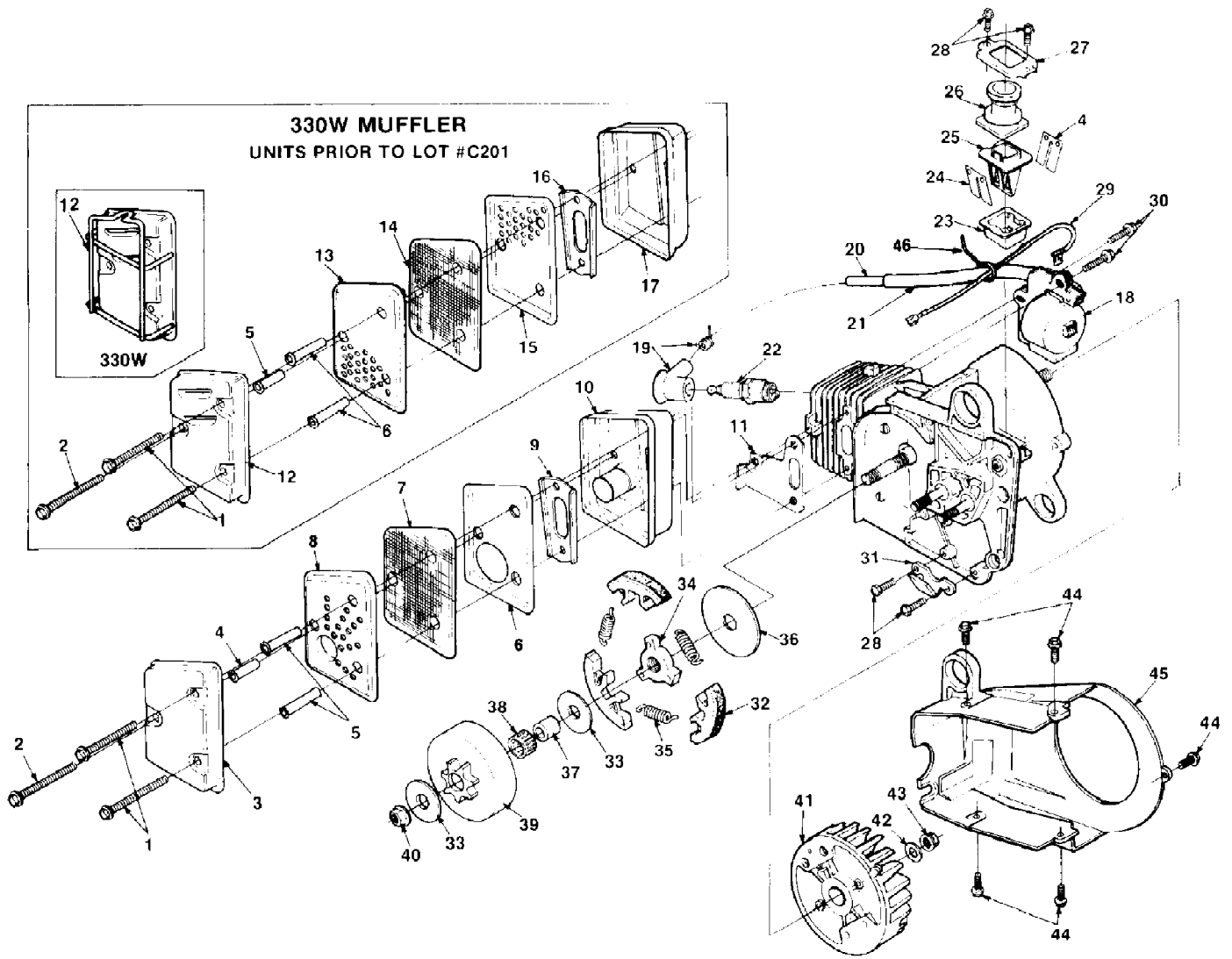

330 Chain Saw UT-10540
Muffler, Clutch & Ignition

Page 9 of 11

Ref #	Part Number	Qty	S/P/F	Description
	A96456	1	/P	MUFFLER
1	88058	2	/P	SCREW- Hex hd. (10-24 x 2 1/4)
2	88057	1	S	SCREW- Hex sems (10-24 x 2)
3	960901	1		CAP- Muffler
4	9398302	1		SPACER- Muffler
5	9398304	1		SPACER- Muffler
6	96091	1		BAFFLE- Muffler
7	96094	1		SCREEN- Spark arrestor
8	96092	1		BAFFLE- Muffler
9	94501	1		PLATE- Reinforcing
10	A968151	1		BODY- Muffler
11	96093A	1		DEFLECTOR- Exhaust
12	938561A	1		CAP- Muffler (units prior to Lot #C201)
	A960691	1	S	CAP- Muffler (units prior to Lot #C201) (330W)
13	93855	1		BAFFLE- Muffler (outer) (prior to Lot #C201) (330W)
14	93504	1		SCREEN- Spark arrestor (330W) (prior to Lot #C201)
15	93515	1		BAFFLE- Muffler (330W) (prior to Lot #C201)
16	94501	1		PLATE- Reinforcing (prior to Lot #C201)
17	938571	1		BODY- Muffler (330W) (prior to Lot #C201)
18	A94361	1		MODULE- Ignition
19	A94754	1		TERMINAL- High tension
20	94362	1		LEAD- High tension
21	95098	1		SLEEVE- Insulation
22	96169S	1	S	SPARK PLUG
23	93836B	1		RETAINER- Reed valve
24	938341	2		VALVE- Reed
25	93835A	1		SEAT- Reed stop
26	93838B	1	S	BOOT- Connector
27	93847	1		RETAINER- Boot
28	80983	4	S	SCREW- (8-32 x 1/2)
29	A94668A	1		LEAD- Electrical
30	88052	2	/P	SCREW- (10-24 x 875)
31	70705	1		STOP- Chain
32	A93632A	3	S	SHOE- Clutch
33	65064	2		WASHER- Thrust
34	94374	1		SPIDER- Clutch
35	93814A	3	S	SPRING- Clutch
36	93643	1		WASHER- Thrust
37	65746B	1	S	RACE- Inner
38	64124	1	S	BEARING- Roller
39	A95621	1		SPROCKET & DRUM- 3/8" pitch 7T
40	81236	1		NUT- Hex (3/8-24)
41	93844A	1		ROTOR
42	95479A	1	/P	WASHER- Flat
43	81255	1		NUT- Lock (rotor nut)
44	88050	5	S	SCREW- Hex sems (10-24 x .625)
45	943412	1		SHROUD- Air
46	46840	1	/P	CABLE TIE

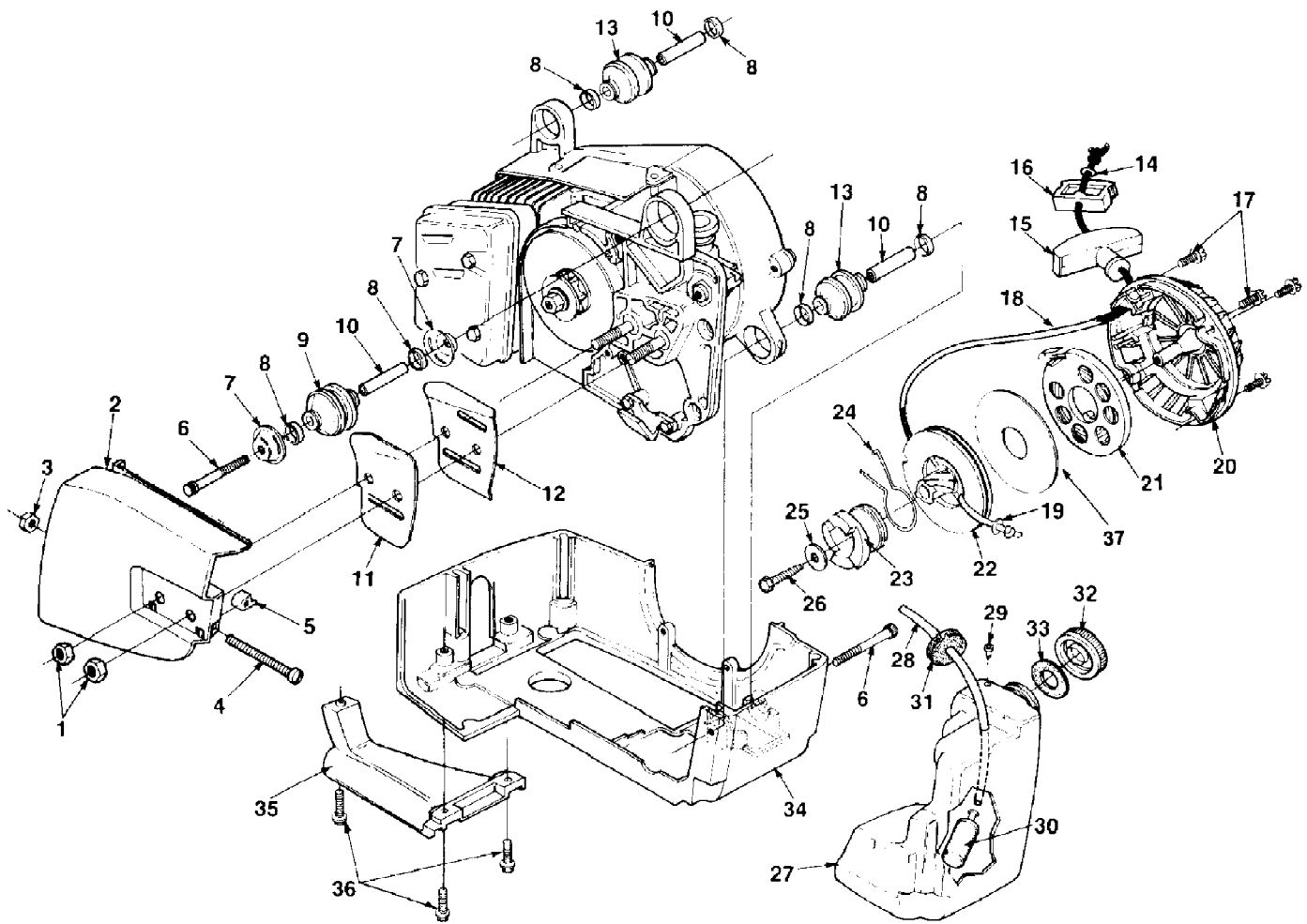

330 Chain Saw UT-10540
Starter & Tank

Page 11 of 11

Ref #	Part Number	Qty	S/P/F	Description
1	81196	2	S/P	NUT- Hex (5/16-18)
2	A946851	1		COVER- Drivecase
3	81206	1	S/P	NUT- Hex (10-32)
4	65175A	1	/P	SCREW- Guide bar adjusting
5	651121	1	S	PIN- Guide bar adjusting
6	82377	2		SCREW- Cap socket hd. (10-24 x 1 3/4)
7	70440A	2		WASHER- Vibration isolator
8	70432A	6	S	RING- Vibration isolator
9	95868	1	/P	ISOLATOR- Vibration
10	70433	3		SPACER
11	95453	1		PLATE- Guide bar (outer)
12	95452	1		PLATE- Guide bar (inner)
13	95915	2	/P	ISOLATOR- Vibration
14	84025	1	/P	WASHER- Flat (#8)
15	A69962B	1	/P	GRIP- Starter
16	70018A	1	/P	INSERT- Rope
17	80983	4	S	SCREW- (8-32 x 1/2)
18	A93876	1	S	ROPE- Starter
19	93862	1	/P	WASHER- Nylon
20	A94736	1		HOUSING- Starter
21	A94918A	1	S	SPRING- Rewind w/retainer
22	94383A	1	S	PULLEY- Starter
23	94384	1		RATCHET- Starter
24	94505A	1	S	LEVER- Ratchet
25	95208	1	S	WASHER
26	82392	1		SCREW- Thd. forming (#10 x 1 1/4)
27	A94678A	1		TANK- Fuel
28	9311230	1	/P	TUBING- 7 1/2 (fuel)
29	96841	1	S	VALVE- Check
30	96639	1	S	FILTER- Fuel
31	95206	1		SEAL- Foam
32	A94671	1		CAP- Fuel
33	94390	1	S	GASKET- Filler cap
34	938302	1		HOUSING- Engine (bottom)
35	94763	1		BRACE- Handle
36	88051	3		SCREW- Sems hex hd. (10-24 x 3/4)
37	12320A	1		SHIELD
	A04291	1		ASSEMBKY- Complete Starter