

No
Diagram
Available

Parts List
Only

Ref #	Part Number	Qty	S/P/F	Description
	PT12371MD	1		Guide Bar (Power Tip) 12" (3/8" pitch)
	H1N7245AH	1		Chain (3/8" pitch)
	PT14371MD	1	/P	Guide Bar (Power Tip) 14" (3/8" pitch)
	H1N7252AH	1	S	Chain (3/8" pitch)
	PT16371MD	1	/P	Guide Bar (Power Tip) 16" (3/8" pitch)
	H1N7256AH	1	S	Chain (3/8" pitch)
	PT18371MD	1	/P	Guide Bar (Power Tip) 18" (3/8" pitch)
	H1N7262AH	1	S	Chain (3/8" pitch)
	PL13321MA	1		Guide Bar (Power Tip) 13" (.325 pitch)
	D1L7256AH	1		Chain or D1L7356AH (.325 pitch)
	PL15321MA	1		Guide Bar (Power Tip) 15" (.325 pitch)
	D1L7264AH	1		Chain (.325 pitch) Or
	D1L7364AH	1		Chain (.325 pitch)
	PT16321MA	1		Guide Bar (Power Tip) 16" (.325 pitch)
	D1L7266AH	1	S	Chain (.325 pitch) Or
	D1L7366AH	1		Chain (.325 pitch)
	PT18321MA	1	S	Guide Bar (Power Tip) 18" (.325 pitch)
	D1L7272AH	1		Chain (.325 pitch) Or
	D1L7372AH	1		Chain (.325 pitch)
	PT20321MA	1	/P	Guide Bar (Power Tip) 20" (.325 pitch)
	D1L7278AH	1		Chain (.325 pitch) Or
	D1L7378AH	1		Chain (.325 pitch)
	PS24823	1	/P	Sealant Silicon
	UP06561	1	S/P	Rubber tubing (10')
	09207	1	/P	Wrench - Combination
	18416	1		Digital Tachometer
	18453	1	/P	Grease, Multi-purpose
	94194	1	/P	Compression Tester
	UP07160	1	S/P	Bit, Torx T27
	UP04562	1	S/P	Carry Case
	UP06732	1	S/P	Bumper Spike Kit

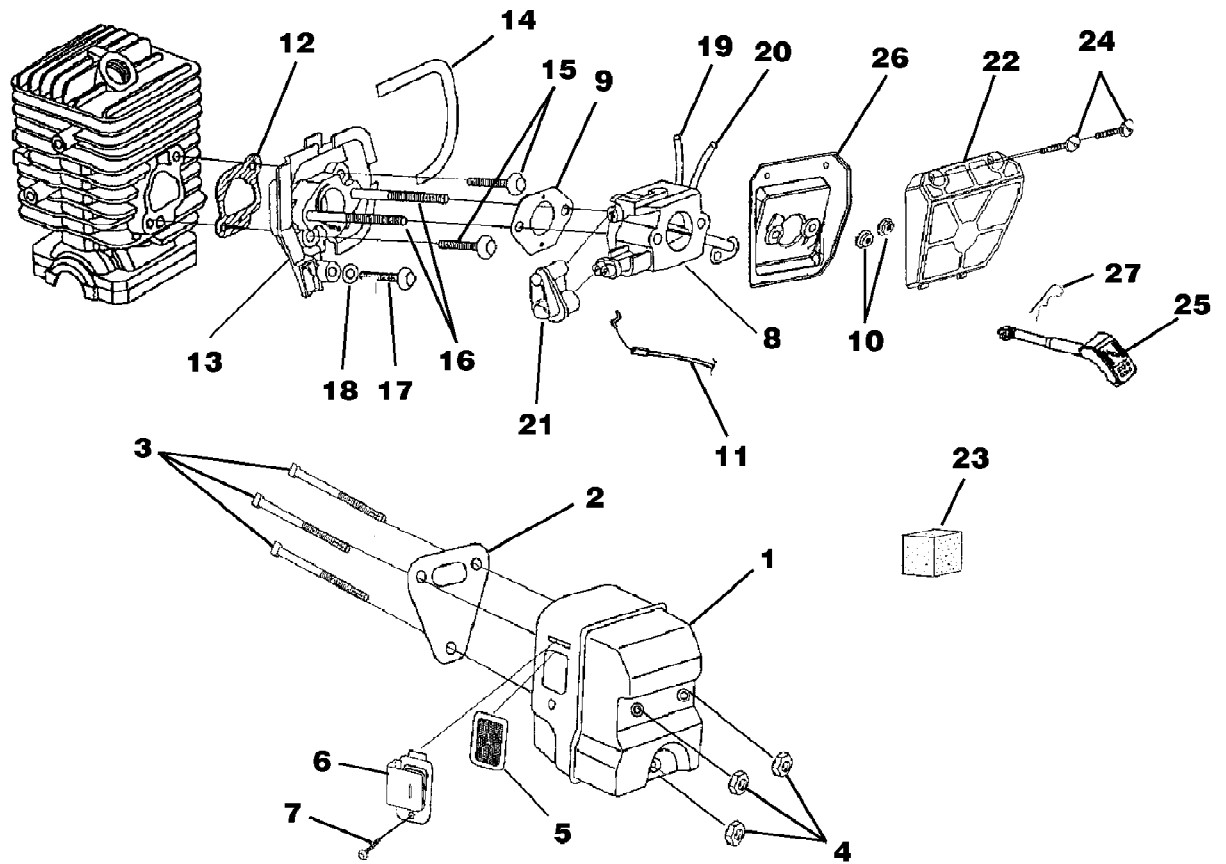

Ref #	Part Number	Qty	S/P/F	Description
1	UP06752	1	S/P	Muffler Kit (33/38cc); Includes items 2-7
	UP00126	1	S	Muffler Kit (45cc)
2	UP04183	1	S	Muffler Gasket
3	UP04049	3	S/P	Screw-Square Hd.
4	UP04059	3	S/P	Nut-Locking Hex (10-32) Torque Specs 50-60 In/Lbs; 5.6-6.7 Nm
5	UP04203	1	S	Screen, Spark
6	UP04204	1	S/P	Deflector, Muffler (33/38cc)
	UP04069	1		Deflector, Muffler (45cc)
7	UP04244	1	S/P	Screw
8	UP06737	1	S/P	Carburetor Assy (33 & 38cc); Includes items 9-10
	UP00125	1	S/P	Carburetor Assy (45cc)
	A09160	1		Carburetor Assy (Int'l 33cc, Int'l 38cc)
	UP00499	1		Carburetor Assy (Int'l 41cc, Int'l 45cc)
9	UP04094	1	S	Carburetor Gasket
10	UP04217	2	S	Flange Nut (10-24) Torque Specs 30-40 In/Lbs; 3.4-4.5 Nm
11	UP04218	1	S/P	Throttle Cable
12	UP04184	1	S/P	Gasket, Heat Dam
13	UP04173	1	S	Heat Dam
14	UP04191	1	S	Seal, Heat Dam
15	UP04084	2	S/P	Screw, Truss Hd. Taptite (10-24 x 7/8") Torque Specs 45-55 In/Lbs; 5.0-6.2 Nm
16	UP04189	2	S	Screw, Carburetor
17	UP03897	1	S	Screw, Thread Form (10-14 x 1/2") Torque Specs 30-40 In/Lbs; 3.4-4.5 Nm
18	UP03867	1	S/P	Washer, Retaining
19	UP04211	1	S	Fuel Line (Tank to Carburetor 8 1/2")
20	UP04209	1	S/P	Fuel Line (Carburetor to Purge Bulb 4")
21	UP04171	1	S	Carburetor Grommet
	UP06753	1	S/P	Air Filter Kit Includes items 22-24
22	UP04533	1	S	Air Filter Cover
23	UP04208	1	S	Pre Filter (In engine housing)
24	UP04235	2	S	Screw-Slotted Pan Hd. (8-16 x 5/8") Torque Specs 15-20 In/Lbs; 1.7-2.3 Nm
25	UP04213	1	S	Rod, Choke
26	UP04178	1	S	Air Filter Plate
27	UP04227	1	S	Spring Clip (Choke Rod)

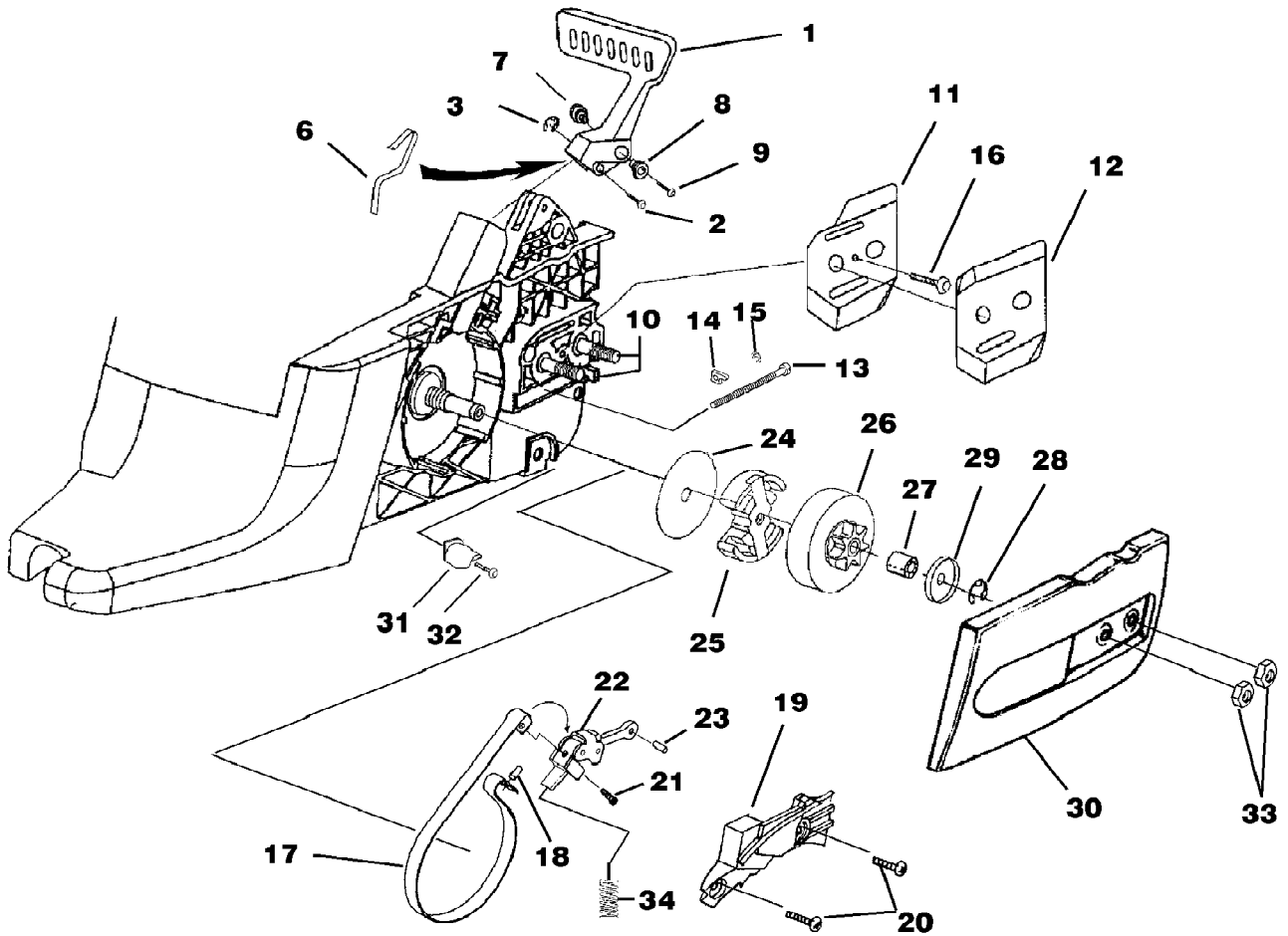

Ref #	Part Number	Qty	S/P/F	Description
1	UP06568	1	S/P	Hand Guard Kit Includes items 2-5
2	UP04214	1	S	Hand Guard Actuating Pin
3	UP04056	1	S	Retaining Ring
?4	UP04207	1	/P	Hand Guard Link (Non-chain brake units-not shown)
?5	UP04090	1	S	Roll Pin (Non-chain brake units-not shown)
6	UP04224	1	S	Spring, Handguard
7	UP04202	1	S	Pivot, L.H.
8	UP04201	1	S	Pivot, R.H.
9	UP04240	1	S	Screw, Hex Socket Hd. (8-32 x 5/8") Torque Specs 25-35 In/Lbs; 2.8-3.9 Nm
10	UP04180	2	S	Guide Bar Bolt
	UP06966	1	S/P	Guide Bar Adjusting Kit Includes items 11-15
11	UP04206	1	S/P	Plate, Guide Bar
12	UP04085	1	S/P	Plate, Guide Bar
13	UP04187	1	S	Screw, Guide Bar Adjusting
14	UP04186	1	S	Pin, Guide Bar Adjusting
15	UP04056	1	S	Ring, Retaining
16	UP04082	1	S	Screw, Thread Form (6-19 x 1/2") Torque Specs 8-18 In/Lbs; .9-2.0 Nm
17	A08680A	1	S/P	Chain Brake Kit Includes items 18-21
18	UP04181	1	S	Pin, Roll
19	UP04309	1	S/P	Cover, Chain Brake
20	UP04082	2	S	Screw, Pan Hd. (6-19 x 1/2") Torque Specs 10-20 In/Lbs; 1.1-2.3 Nm
21	UP04239	1	S	Screw, Pan Hd. (8-16 x .320) Torque Specs 20-30 In/Lbs; 2.3-3.4 Nm
22	UP04223	1	S	Chain Brake Link
23	UP04090	1	S	Pin, Roll
24	UP04182	1	S	Thrust Washer
25	UP06727	1	S/P	Clutch & Hardware Torque Specs 130-180 In/Lbs; 14.7-20.3 Nm
26	UP06967	1	S	Sprocket, Drum (3/8 Pitch) Includes items 27-28
	UP04560	1	S/P	Sprocket, Drum (.325 Pitch) (i3850b & 45cc only)
27	UP04175	1	S	Bearing, Needle
28	UP04228	1	S/P	Ring, Retaining
29	UP04179	1	S/P	Washer, Cupped
30	UP06975	1	S/P	Drive Case Cover Includes items 31-32
31	UP04088	1	S	Stop, Chain
32	UP03900	1	S/P	Screw, Thread Form (10-14 x 3/4") Torque Specs 30-50 In/Lbs; 3.4-5.6 Nm
33	UP04058	2	S	Nut, Hex Torque Specs Hand Tight
34	UP04032	1	S	Spring, Compression

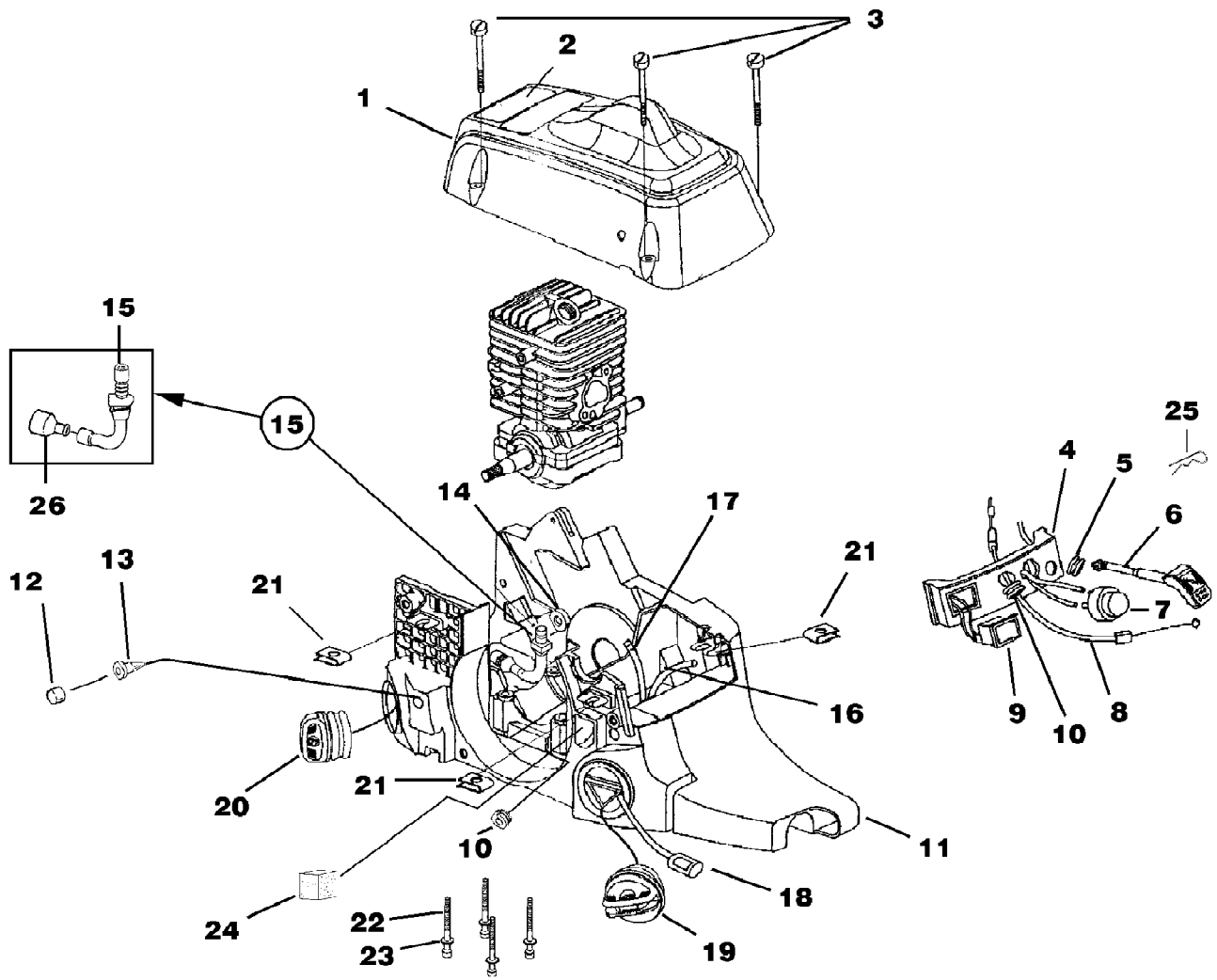

Ref #	Part Number	Qty	S/P/F	Description
1	A08692	1	S	Cylinder Cover Kit Includes items 2-3
2	UP04212	1	S	Safety Decal
3	UP04219	3	S	Screw-Slotted Pan Hd. Torque Specs 15-25 In/Lbs; 1.7-2.8 Nm
4	UP04193	1	S/P	Control Panel
5	UP04052	1	S	Grommet
6	UP04213	1	S	Rod, Choke
7	UP04033	1	S/P	Bulb, Air Purge
8	UP04218	1	S/P	Throttle Cable
9	UP04197	1	S/P	Switch, Rocker
10	UP04215	2	S	Grommet - Split
11	UP06754	1	S/P	Engine Housing Includes items 12-20
12	UP04205	2	S	Element, Filter (Bronze)
13	UP04045	2	S	Duck Bill Valve
14	UP04185	1	S	Oil Outlet Grommet
15	UP04048	1	S/P	Oil Intake Tube
16	UP04210	1	S/P	Rubber Tubing (5 1/2")
17	UP04211	1	S	Rubber Tubing (8 1/2")
18	UP03871	1	S/P	Fuel Filter
19	DA07590	1	S	Fuel Cap w/ Retainer
20	DA07591	1		Oil Cap w/ Retainer
	UP04054	1		Oil Filter (Not Shown)
	UP04180	2	S	Guide Bar Bolt (Not Shown)
21	UP04221	3	S	Speed Nut ("U-Type")
22	UP04083	4	S	Screw, Cap-Socket Hd. (10-24 x 2") Torque Specs 65-76 In/Lbs; 7.3-8.5 Nm
23	UP04087	4	S	Washer
24	UP04208	1	S	Pre Filter
25	UP04227	1	S	Spring Clip (Choke Rod)
26	UP04054	1		Oil Filter

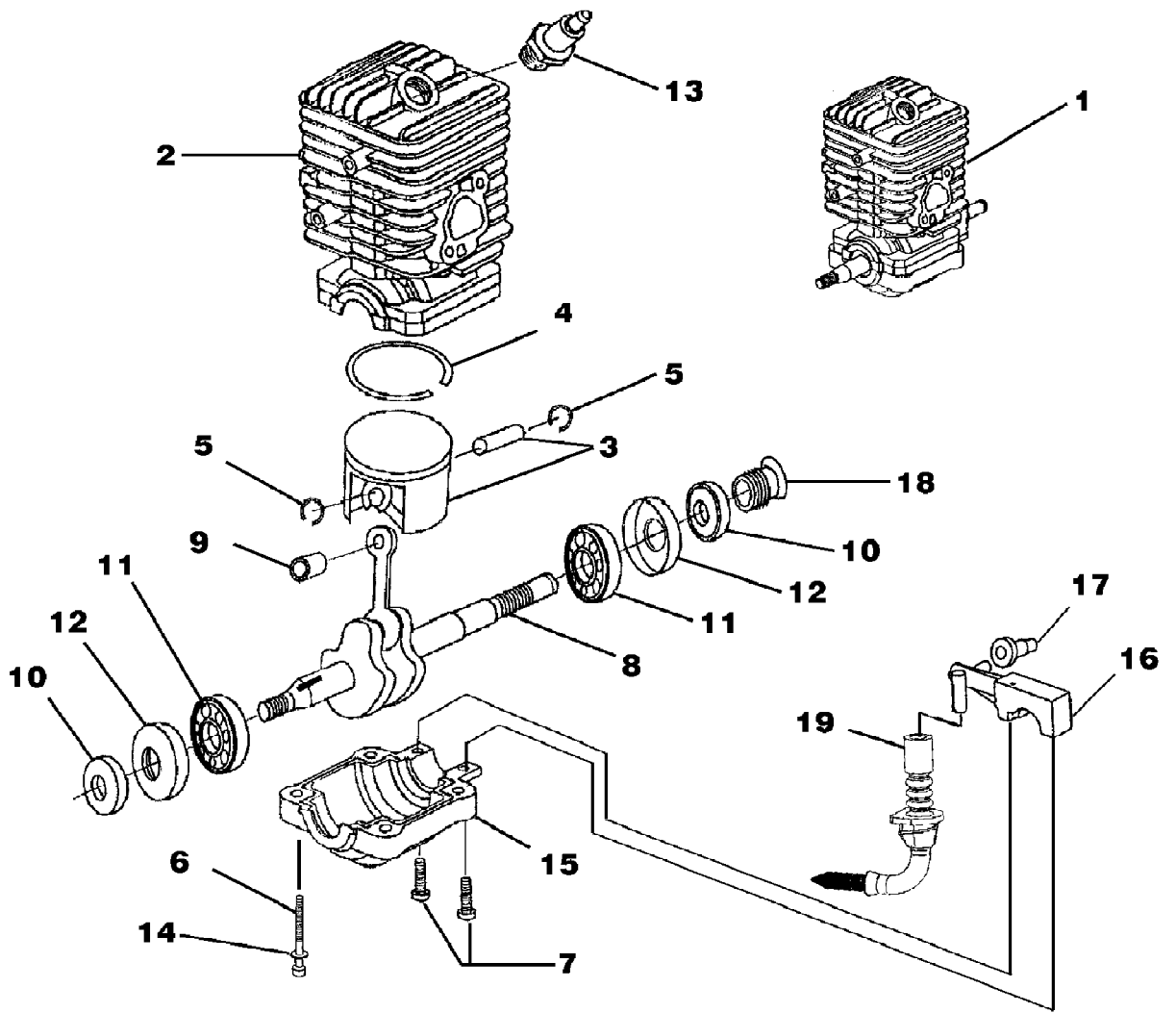

Ref #	Part Number	Qty	S/P/F	Description
1	UP03119	1	S	Short Block Complete (33cc); Includes items 2-12
	UP04161	1	/P	Short Block Complete (38cc)
	UP04166	1	S	Short Block Complete (45cc)
2	A08666	1	S	Cylinder Kit (33cc)
	A08667	1	S/P	Cylinder Kit (38cc)
	UP00129	1	S	Cylinder Kit (45cc)
	UP04183	1	S	Gasket, Muffler (Not Shown)
	UP04184	1	S/P	Gasket, Heat Dam (Not Shown)
	UP04094	1	S	Gasket, Carburetor (Not Shown)
3	UP06971	1	S/P	Piston & Pin (33cc); Includes items 4-5
4	UP04177	1	S	Piston Ring (33cc)
5	UP04051	2	S	Ring, Retaining
3	A08669	1	S	Piston & Pin (38cc); Includes items 4-5
4	UP04190	1	S	Piston Ring (38cc)
5	UP04051	2	S	Ring, Retaining
3	UP00130	1	S	Piston & Pin (45cc); Includes items 4-5
4	UP04231	1	S	Piston Ring (45cc)
5	UP04051	2	S	Ring, Retaining
6	UP04083	4	S	Screw, Cap-Socket Hd. (10-24 x 2") Torque Specs 65-75 In/Lbs; 7.3-8.5 Nm; Required Loctite 262 Red
7	UP03898	2	S	Screw, Pan Hd., Plastite (8-16 x 5/8") Torque Specs 15-20 In/Lbs; 1.7-2.3 Nm
8	UP03118	1	S	Crankshaft & Rod Assy (33 & 38cc); Includes items 9-12
	UP04165	1	S	Crankshaft & Rod Assy (45cc)
9	UP04174	1	S/P	Bearing, Needle Includes items 10-12
10	UP04047	2	S	Shaft Seal
11	UP04176	2	S/P	Bearing & Rubber Case Includes item 12
12	UP04046	2	S	Rubber Case
13	UP04093	1	S	Spark Plug Torque Specs 120-180 In/Lbs; 13.6-20.3 Nm
14	UP04087	4	S	Washer
15	UP04172	1	S	Lower Crankcase (33 & 38cc)
	UP04232	1	S	Lower Crankcase (45cc)
16	UP06602	1	/P	Oil Pump Kit Includes items 17-19
17	UP04185	1	S	Grommet, Oil Outlet
18	UP04188	1	S	Left Hand Worm
19	UP04048	1	S/P	Oil Intake Tube w/Filter

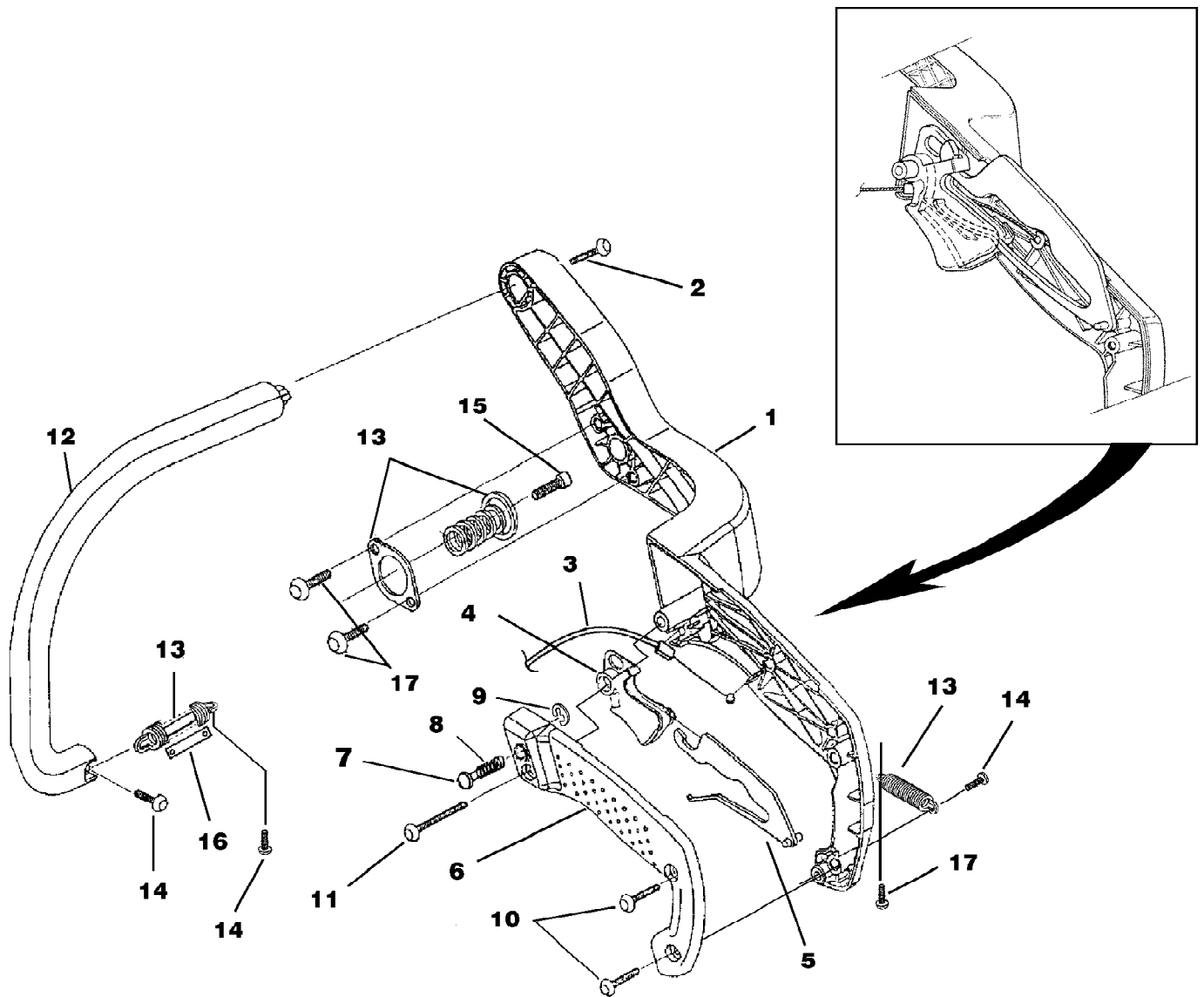

Ref #	Part Number	Qty	S/P/F	Description
1	A08675	1	S	Rear Handle Kit Includes items 2-11
2	UP04234	1	S/P	Screw-Pan Hd. (12-14 x 1 1/2") Torque Specs 40-50 In/Lbs; 4.5-5.6 Nm
3	UP04218	1	S/P	Throttle Cable
4	UP04195	1	S/P	Trigger, Throttle
5	UP04196	1	S	Throttle Lock Out
6	A08683	1	S	Handle Cover Kit Includes items 7-10
7	UP04199	1	S	Throttle Lock Pin
8	UP04226	1	S	Spring, Compression
9	UP04050	1	S	Ring, Retainer
10	UP03900	2	S/P	Screw, Thread Form (10-14 x 3/4") Torque Specs 30-40 In/Lbs; 3.4-4.5 Nm
11	UP04238	1	S	Screw, Thread Form (10-14 x 1 3/8") Torque Specs 30-40 In/Lbs; 3.4-4.5 Nm
12	UP06973	1	S/P	Front Handle Kit
	UP04234	1	S/P	Screw-Pan Hd. (12-14 x 1 1/2") (See No. 2 above)
13	A08677	1	S	Isolator Kit Includes 14-16
14	UP04237	3	S	Screw, Truss Hd. (10-14 x 5/8") Torque Specs 30-40 In/Lbs; 3.4-4.5 Nm
15	UP04233	1	S	Screw, Truss Hd. (10-24 x 5/8") Torque Specs 40-50 In/Lbs; 4.5-5.6 Nm
16	UP04200	1	S	Limitier, Isolator
17	UP03897	3	S	Screw, Thread Form (10-14 x 1/2") Torque Specs 30-40 In/Lbs; 3.4-4.5 Nm

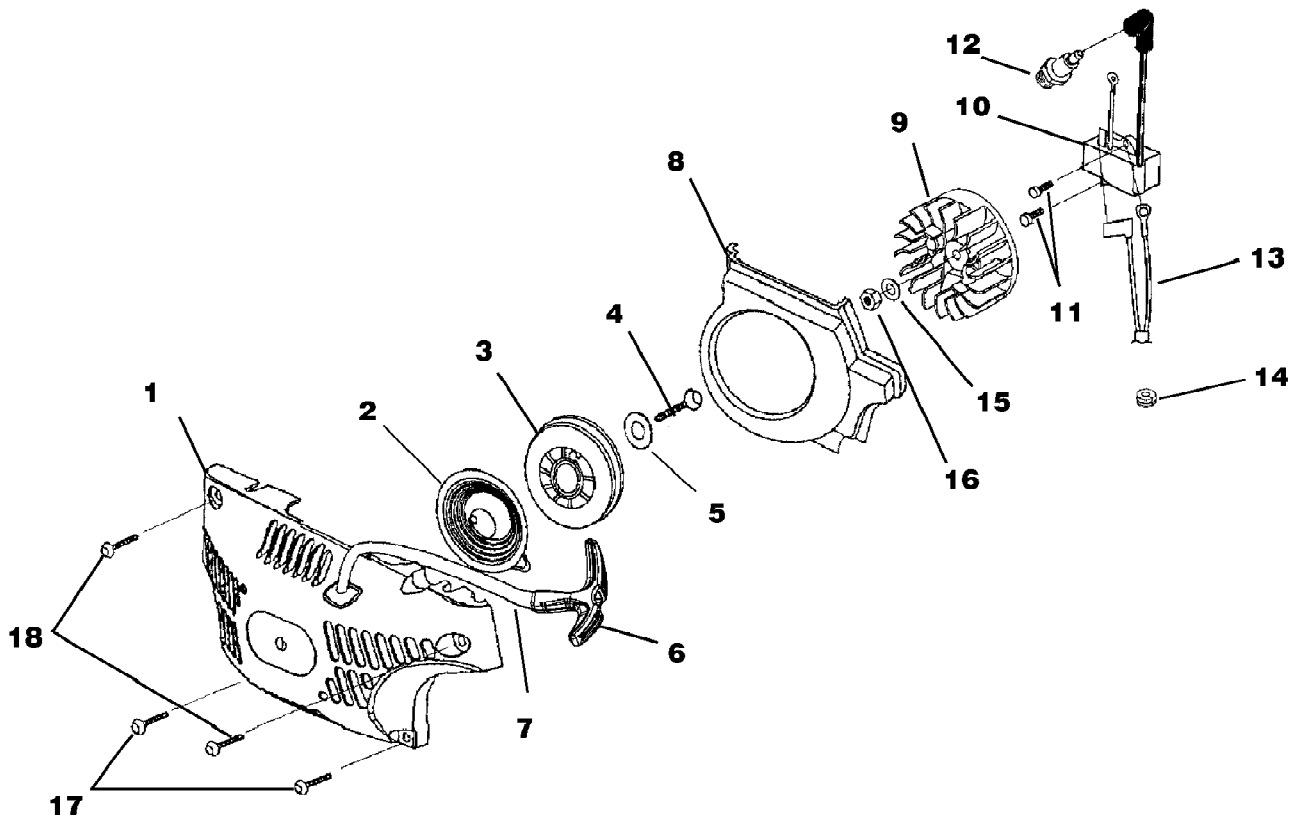

Ref #	Part Number	Qty	S/P/F	Description
1	UP06749	1	S/P	Starter Kit Includes items 2-7
2	UP04092	1	S	Spring & Container
3	UP05460	1	S/P	Pulley, Starter
4	UP04237	1	S	Screw, Thread Form (10-14 x 5/8") Torque Specs 30-40 In/Lbs; 3.4-4.5 Nm
5	UP04089	1	S/P	Washer, Retaining
6	UP04216	1	S	Grip, Starter
7	UP03911	1	S	Rope, Starter 46"
8	UP04192	1	S	Baffle, Fan Housing
9	UP05850	1	S	Rotor & Starter Pawl
10	A08676A	1	S	Ignition Kit (33cc models); Includes item 11
	UP05851	1	S	Ignition Kit Both kits include:
11	UP04086	2	S/P	Screw, Thread Form (8-32 x 5/8") Torque Specs 30-40 In/Lbs; 3.4-4.5 Nm
12	UP05875	1	S	Spark Plug Torque Specs 120-180 In/Lbs; 13.6-20.3 Nm
13	UP04222	1	S	Ignition Switch Harness
14	UP04215	1	S	Grommet, Wire Harness (Split)
15	UP04241	1	S/P	Washer, Flat
16	UP04081	1	S	Nut, Jam Torque Specs 100-150 In/Lbs; 11.3-16.9 Nm
17	UP04236	2	S	Screw, Truss Hd. (10-14 x 7/8") Torque Specs 30-40 In/Lbs; 3.4-4.5 Nm
18	UP04237	2	S	Screw, Truss Hd. (10-14 x 5/8") Torque Specs 30-40 In/Lbs; 3.4-4.5 Nm