

No  
Diagram  
Available  
  
Parts List  
Only

Ref #	Part Number	Qty	S/P/F	Description
	A70776B	1	/P	SAFE T TIP (Standard)
	18453	1	/P	GREASE - Multi Purpose
	A70239E	1		KIT - Repair (sprocket nose bar)
	D24814B	1		WRENCH (combination)
	PS24823	1	/P	SILASTIC (crankcase sealing)
	A24747A	1		PULLER - Magneto Rotor
	HT10001O4	1		GUIDE BAR
	H1N7242AH	1		(35-MD50-42) CHAIN
	HT12001O4	1		GUIDE BAR
	H1N7248BH	1		(35-MD50-48) CHAIN
	PT12371O4	1		GUIDE BAR
	H1N7248BH	1		(35-MD50-48) CHAIN
	PT14371O4	1		GUIDE BAR
	H1N7253AH	1	S	(35-MD50-53) CHAIN
	PT16371O4	1		GUIDE BAR
	H1N7259AH	1	S	(35-MD50-53) CHAIN
	PT18371O4	1		GUIDE BAR
	H1N7264AH	1		(35-MD50-64) CHAIN
	JA313164	1		IGNITION TEST SPARK PLUG
	22486	1		SHIM (0.015" AIR GAP)
	2498201	1		T25 TORX DRIVE BIT
	1856601	1	/P	T27 TORX DRIVE BIT

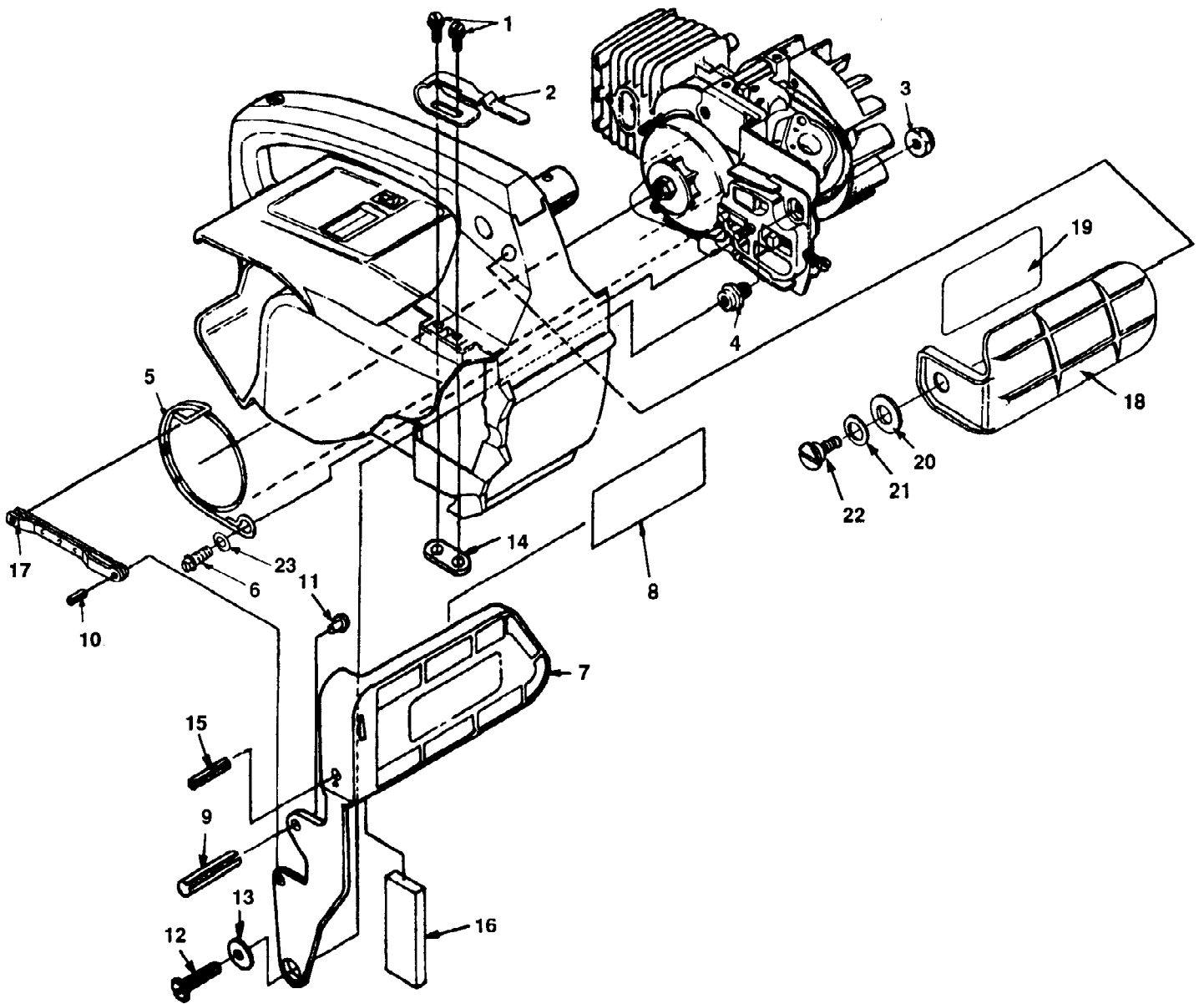

200 Chain Saw UT-10690-E  
Chain Brake

Page 4 of 12

Ref #	Part Number	Qty	S/P/F	Description
1	88043	2	/P	SCREW - Hex Hd. w/Washer (8-32 X 1/2")
2	02635	1		CLIP - Retaining
3	81124A	1	/P	NUT - Hex, Jam
4	70636	1		POST - Chain Brake
5	70637C	1	S	BAND - Brake
6	82538	1	/P	SCREW - Thread Form (10-24 x 3/4")
7	A03061A	1		HANDGUARD & LEVER (200, Super 2 SL)
8	02661	1		DECAL - Safety
9	JA461383	1		PIN - Roll (3/16 X 1")
10	95395A	1	/P	PIN - Roll
11	82367	1	/P	SCREW - Drive
12	82166	1		SCREW - Machine, Pan Hd. (10-32 X 1/2")
13	70632	1	/P	WASHER - Flat
14	02637	1		NUT - Weld
15	JA461361	1		PIN - Roll
16	07567	1		WEIGHT - Handle (International Only)
17	A70767	1		PIVOT - Link
18	A70796C	1	S	HANDGUARD KIT (Super 2, XL, 180 & 192 )
19	02661	1		DECAL - Handguard
20	95694	1		WASHER - Curve Spring
21	96102	1		WASHER Flat
22	95714	1	S	SCREW - Shoulder
23	84008	1	S/P	WASHER - Flat (#10)

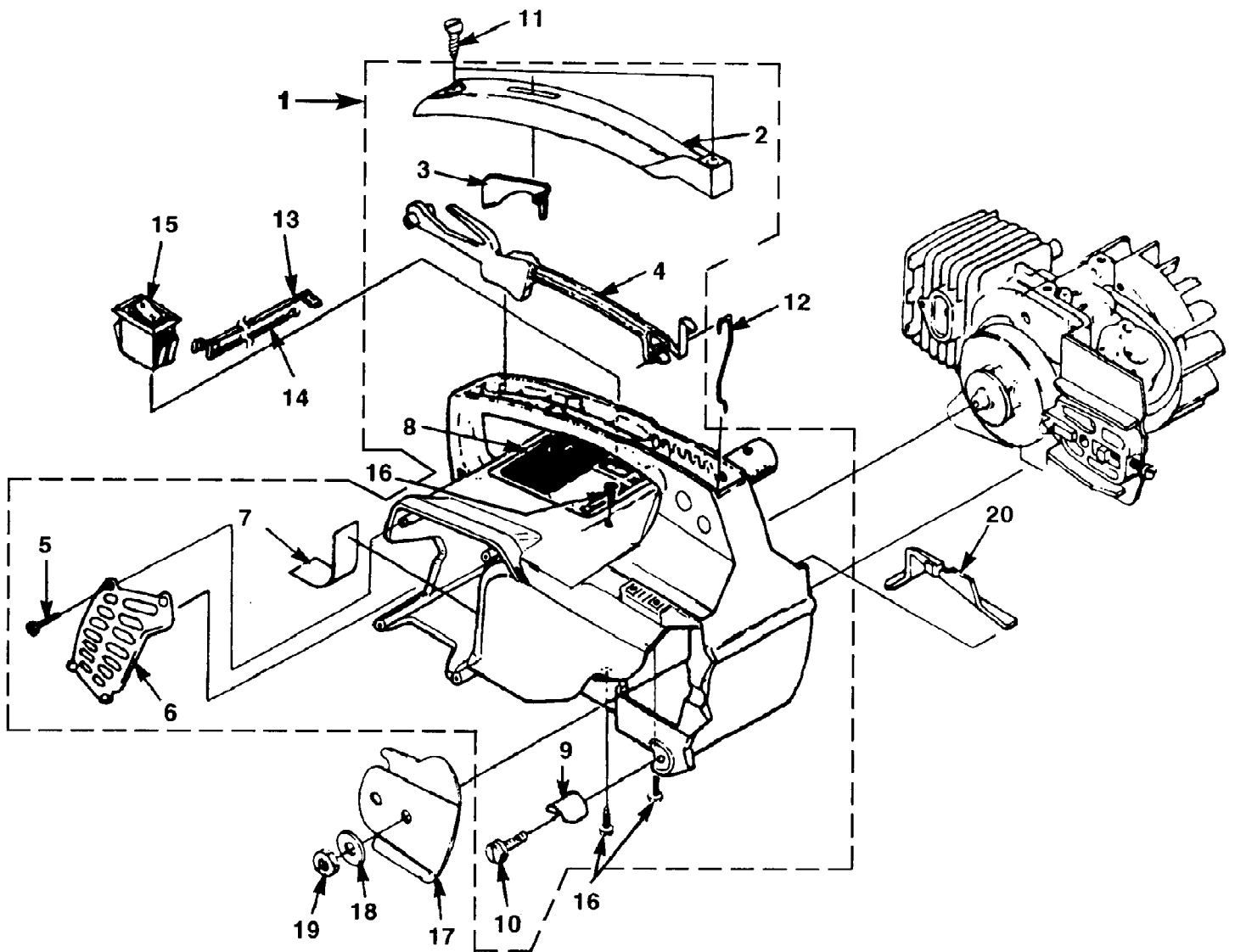

200 Chain Saw UT-10690-E  
Engine Housing

Page 6 of 12

Ref #	Part Number	Qty	S/P/F	Description
1	A07553	1		ENGINE HOUSING KIT
2	02495	1		COVER - Handle
3	02493	1		LOCK - Trigger
4	02492A	1		TRIGGER
5	82528	4	/P	SCREW - Pan, plastite (#6 X 3/8") (Torque Specs: 8-12 in/lbs, .9-1.4 Nm)
6	02765	1		SHIELD - Muffler
7	95615	2	S/P	TAPE
8	02506	1		DECAL - Warning
9	95212	1	/P	STOP - Chain
10	82563	1	/P	SCREW - Torx, plastite (#10 X 3/4") (Torque Specs: 30-50 in/lbs, 3.4-5.8 Nm)
11	94065	2		SCREW - Pan, plastite (#10-16 X 3/4") (Torque Specs: 15-20 in/lbs, 1.7-2.3 Nm)
12	02501	1	/P	ROD - Throttle
13	A02482	1	S	LEAD - w/Flag Term.
14	A02484	1		LEAD - w/Ring Term.
15	02497	1	S/P	SWITCH
16	82538	4	/P	SCREW - Torx, taptite (10-24 X 3/4") (Torque Specs: 55-65 in/lbs, 6.3-7.5 Nm)
17	04440	1		PLATE - Guide Bar
18	69309A	1	/P	WASHER - Flat
19	810652	1	S	NUT - Hex
20	02481A	1		COVER - AIR Filter

200 Chain Saw UT-10690-E  
Engine Internal (192, Super 2, 200, Super 2 SL)

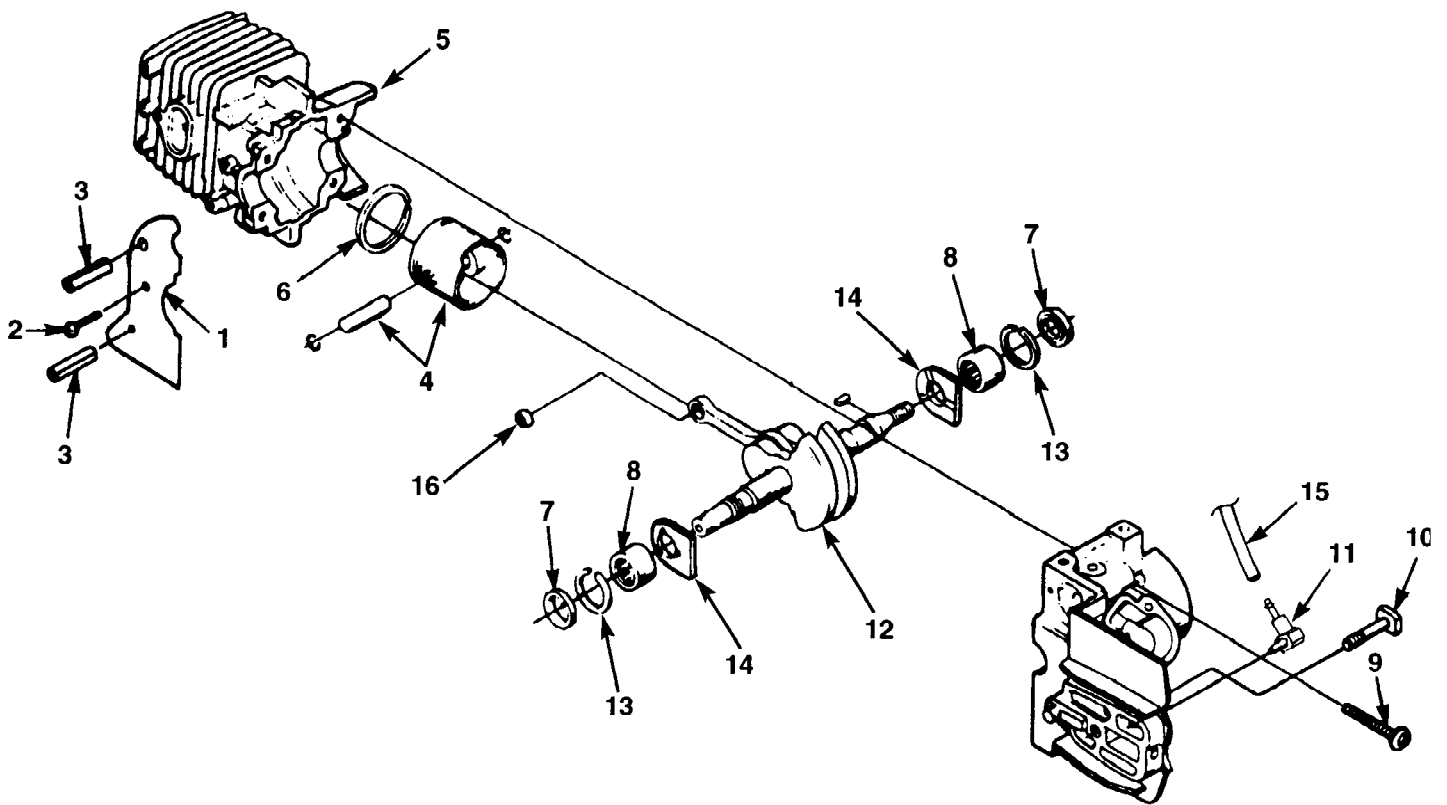

200 Chain Saw UT-10690-E  
 Engine Internal (192, Super 2, 200, Super 2 SL)

Page 8 of 12

Ref #	Part Number	Qty	S/P/F	Description
1	02639	1	/P	SAW DUST SHIELD
2		1		SCREW - Tapping (#6-32 x 5/16") (Not used on this model.)
3		1		PIN - Roll (5/32 x 1 1/8") (Not used on this model.)
	A01105A	1	/P	SHORT BLOCK (192, Super 2, 200, Super 2 SL)
	UP00070	1	S	SHORT BLOCK (192, Super 2, 200, Super 2 SL) (After S/N HR0010001)
4	A98967A	1	S	PISTON & PIN ASSY.
5	04328A	1	S	CYLINDER
	UP00071	1	S	CYLINDER (After S/N HR0010001)
6	93165	1		RING - Piston
7	07025	2	S	SEAL - Shaft
8	12530	2		BEARING - Needle
9	82567	4		SCREW - Torx Pan Hd. (10-24 x 1 1/8") (Torque Specs: 65-75 in/lbs, 7.5-8.6 Nm)
10	69195	1	/P	BOLT - Guide Bar
11	07510	1		VALVE - Check
12	A97611A	1	S	CRANKSHAFT - Rod and Bearing
13	07025	2	S	SEAL z - Shaft
14	03962	2		WASHER - Thrust
15	0745432	1		TUBING - Rubber (Oil Line) (8")
	0745499	1	/P	TUBING - Rubber (Oil Line) (10')
16	02035	1	/P	BEARING - Wrist Pin



200 Chain Saw UT-10690-E  
Ignition, Rotor, Carburetor & Clutch

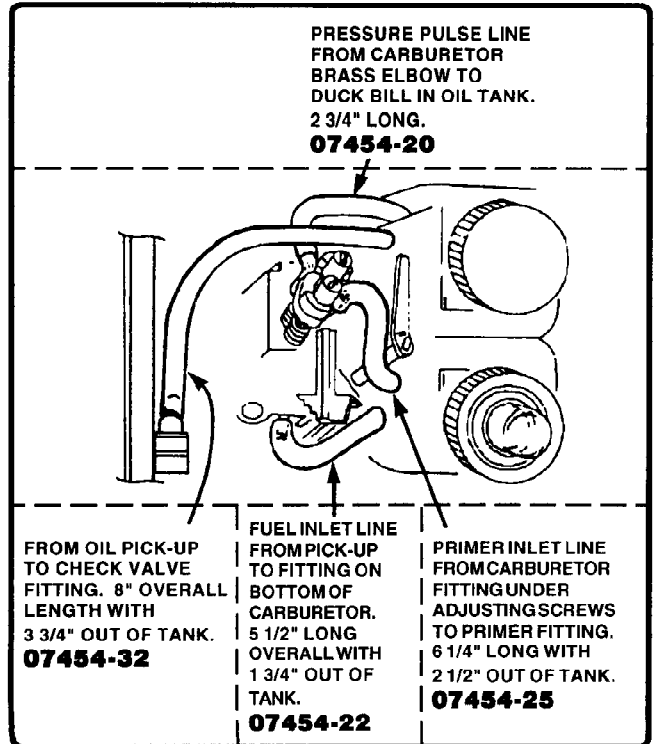
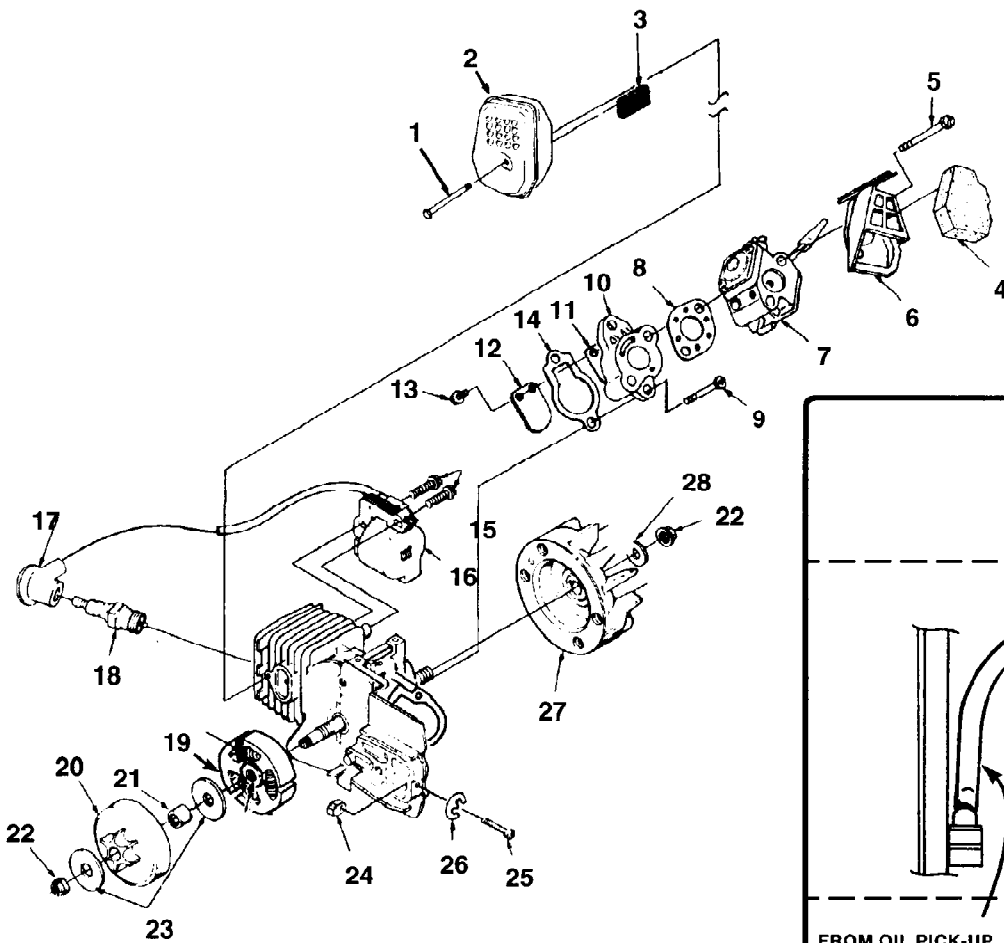

200 Chain Saw UT-10690-E  
Ignition, Rotor, Carburetor & Clutch

Page 10 of 12

Ref #	Part Number	Qty	S/P/F	Description
1	93460	1	/P	SCREW - Machine Hex Sems (#8-32 X 3/4") (Torque Specs: 50-60 in/lbs, 5.7-6.9 Nm)
2	A02459	1		MUFFLER
3	02458	1		SCREEN - Spark Arrestor
4	02500	1	S	FILTER - Air
5	00167	2	/P	SCREW - Thread Forming (Torque Specs: 35-45 in/lbs, 4.0-5.2 Nm)
6	02491A	1		BOX - Air Filter
7	A01373B	1	/P	CARBURETOR (Zama)
8	02488	1	S	GASKET - Carburetor
9	82589	2	/P	SCREW - Plastite, (10-14 X 1") (Torque Specs: 65-75 in/lbs, 7.5-8.6 Nm)
10	A02499	1		HEAT DAM
11	95983	1	S	REED
12	03205	1		STOP - Reed
13	82498	2	/P	SCREW - Hex Taptite (4-40 X 3/8") (Torque Specs: 10-15 in/lbs, 1.1-1.7 Nm)
14	02453	1	/P	GASKET - Intake Manifold
15	82540	2	/P	SCREW - Thread Forming (8-32 X 1") (Torque Specs: 30-40 in/lbs, 3.5-4.6 Nm)
16	94711CS	1	/P	MODULE - Ignition
17	A33055	1	/P	TERMINAL
18	96169S	1	S	SPARK PLUG (Champion DJ7Y) (Torque Specs: 120-180 in/lbs, 13.8-20.7 Nm)
	79252	1	S	SPARK PLUG (Champion RDJ7Y) (Torque Specs: 120-180 in/lbs, 13.8-20.7 Nm)
19	A97921A	3	/P	CLUTCH KIT
20	A95653E	1	/P	SPROCKET & DRUM
21	70277	1	S	BEARING
22	81229A	2	/P	NUT - Rotor (5/16-24) (Torque Specs: 100-150 in/lbs, 11.5-17.3 Nm)
23	95299	2	/P	WASHER - Thrust
24	692542	1	/P	PIN - Adjusting
25	A00440	1	/P	SCREW & E-RING KIT
26	93574	1	S	E-RING
27	A04158S	1	S	ROTOR & STARTER PAWL
28	84065	1	S	WASHER - 5/16"
0745432	0745432	1		LINE - (8")
0745420	0745420	1		PRESSURE PULSE LINE
0745425	0745425	1		PRIMER INLET LINE
0745422	0745422	1	/P	FUEL INLET LINE

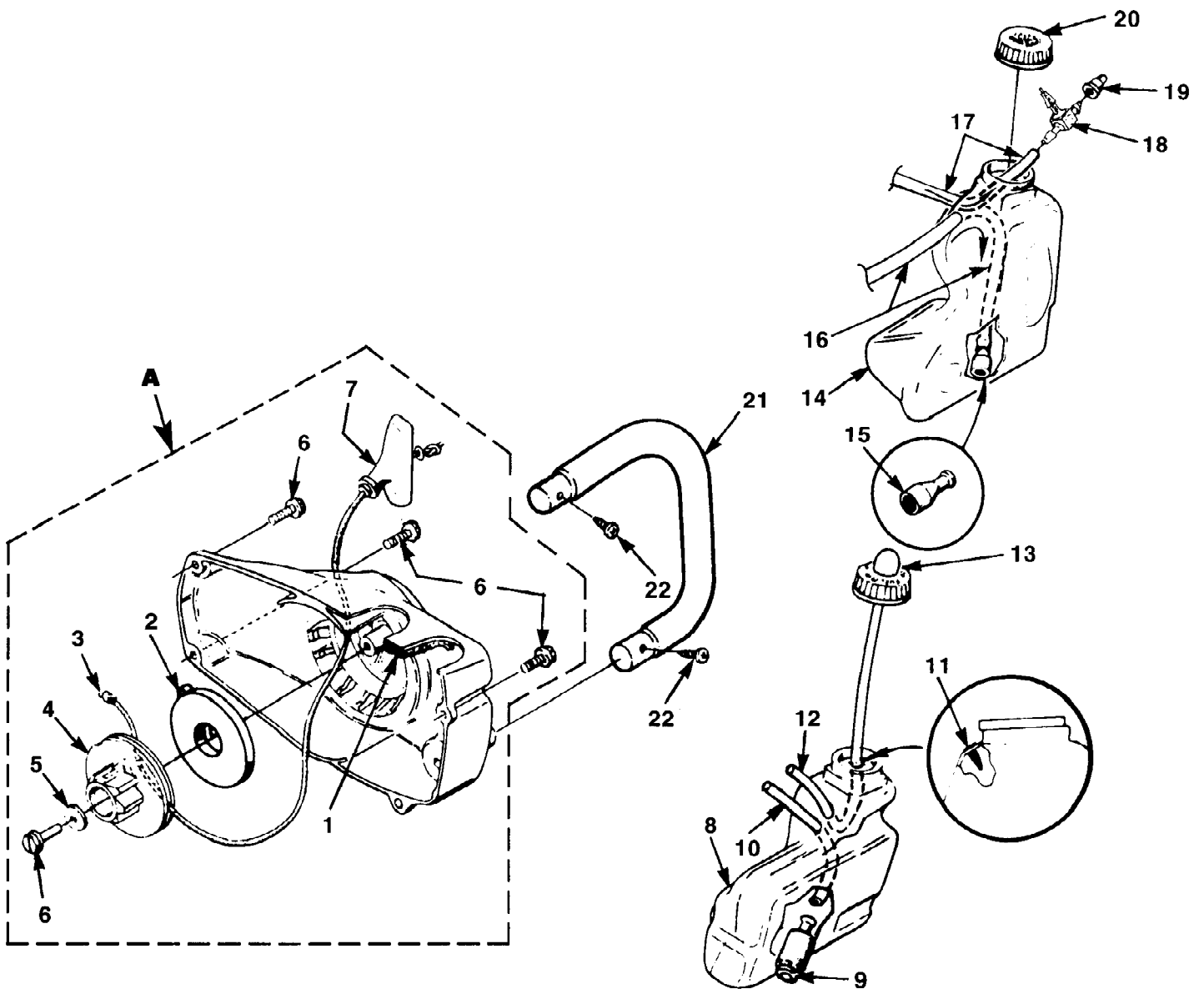

200 Chain Saw UT-10690-E  
Starter & Fuel Tank

Page 12 of 12

Ref #	Part Number	Qty	S/P/F	Description
A	A06268A	1	/P	STARTER ASSY., Complete
1	69443	1		FILTER
2	A97908	1	/P	SPRING & CONTAINER
3	9789901	1	/P	ROPE - Starter (46")
	98052A	1	/P	ROPE - Starter (250 Ft. Reel)
4	97768B	1	S	PULLEY - Starter
5	94062	1	/P	WASHER - Retaining
6	82563	5	/P	SCREW - Torx (#10 X 3/4") (Torque Specs: 30-50 in/lbs, 3.4-5.8 Nm)
7	02264	1	S	GRIP - Starter
8	A06272	1		FUEL TANK
9	49422	1	S	FILTER - Fuel
10	0745422	1	/P	LINE - Fuel (5 1/2")
11	98819	1	/P	VALVE - Duck Bill
12	0745425	1		TUBING - Return (6 1/4")
	0745499	1	/P	TUBING - Rubber (10 Ft. Length)
13	A01372A	1	/P	PRIMER & CAP
14	A07554	1	/P	OIL TANK
15	A68593	1		FINDER - Oil
16	0745432	1		TUBING - Rubber (8")
17	0745420	1		TUBING - Rubber (5")
18	A07508	1		FITTING - Vent
19	96841	1	S	VALVE - Check
20	A97359A	1	S	OIL CAP
21	A07558	1	/P	HANDLE BAR
22	94065	2		SCREW - Pan Plastite (#10-16 X 3/4") (Torque Specs: 15-20 in/lbs, 1.7-2.3 Nm)