

For Parts Call 606-678-9623 or 606-561-4983

**RYOBI
18 VOLT HEDGE TRIMMER
MODEL NO. P2601
REPAIR SHEET**

www.mymowerparts.com

RYOBI 18 VOLT HEDGE TRIMMER - MODEL NUMBER P2601

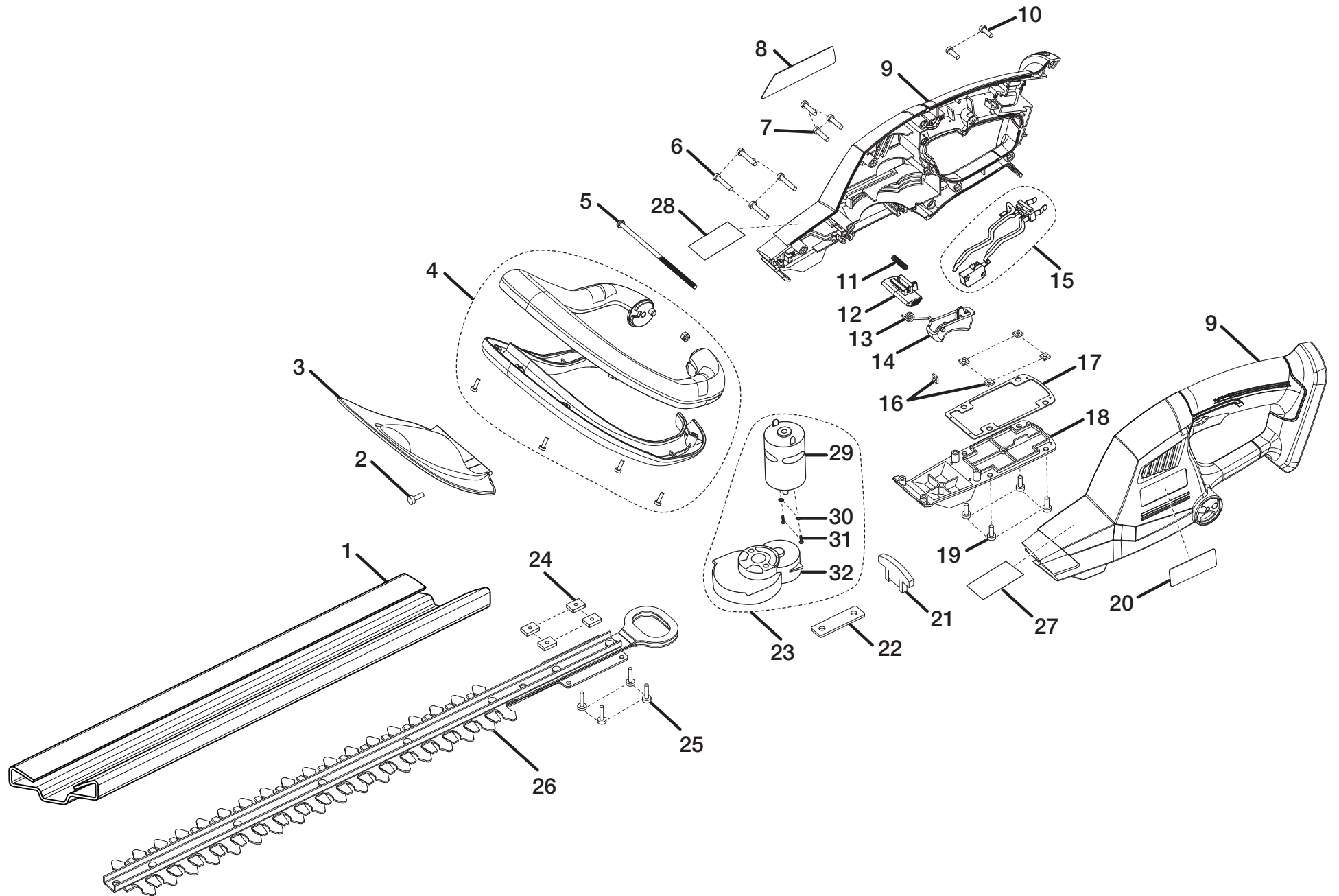

RYOBI 18 VOLT HEDGE TRIMMER – MODEL NUMBER P2601

The model number will be found on a plate attached to the motor housing. Always mention the model number in all correspondence regarding your **HEDGE TRIMMER** or when ordering repair parts.

PARTS LIST

KEY NO.	PART NUMBER	DESCRIPTION	QTY	KEY NO.	PART NUMBER	DESCRIPTION	QTY
1	518463005	Blade Cover	1	19	660137001	* Screw (M4 x 12 mm)	4
2	660033002	* Screw (M4 x 12 mm)	1	20	940015138	Logo Label	1
3	516833001	Guard Block	1	21	561998001	Sponge Seal	1
4	302373002	Front Handle Assembly	1	22	690405001	Bar Plate	1
5	660208095	* Screw (M4 x 114 mm)	1	23	210010041	Motor & Gear Train Assembly (Inc. Key Nos. 29-32)	1
6	660208049	* Screw (M4 x 22 mm Pan Hd.)	4	24	660561001	* Square Nut (M4 x 15 x 10.9)	4
7	660208052	* Screw (M4 x 16 mm Pan Hd.)	3	25	660137003	* Screw (M4 x 16 mm)	4
8	940304437	Data Label	1	26	302374001	Blade Assembly	1
9	200208012	Housing Assembly	1	27	940304544	Warning Label	1
10	660208055	* Screw (M4 x 12 mm Pan Hd.)	2	28	940006202	Warning Label	1
11	670499001	Compression Spring	1	29	230033035	Motor Assembly	1
12	516837001	Trigger Lock	1	30	670704001	Retaining Ring (External)	2
13	672752001	Trigger Spring	1	31	660137001	* Screw (M4 X 13 mm)	2
14	516838001	Trigger	1	32	301705001	Gear Train Assembly	1
15	270015144	Switch and Circuit Assembly	1		987000314	Operator's Manual (960009363)	
16	660126001	* Square Nut (M4 x 2.2 mm)	5		9-22-08		
17	561971001	Rubber Seal	1		(Rev:02)		
18	516834001	Bottom Cover	1				

WARNING: Improper repair of a double insulated tool can result in damage to the double insulation system possibly causing electrical shock or electrocution. Any repairs requiring disassembly of your tool requires safety testing and should only be performed by a Ryobi Authorized Service Center. For the service center nearest you call 1-800-860-4050.

* STANDARD HARDWARE ITEM – MAY BE PURCHASED LOCALLY

RYOBI 18 VOLT HEDGE TRIMMER - MODEL NUMBER P2601

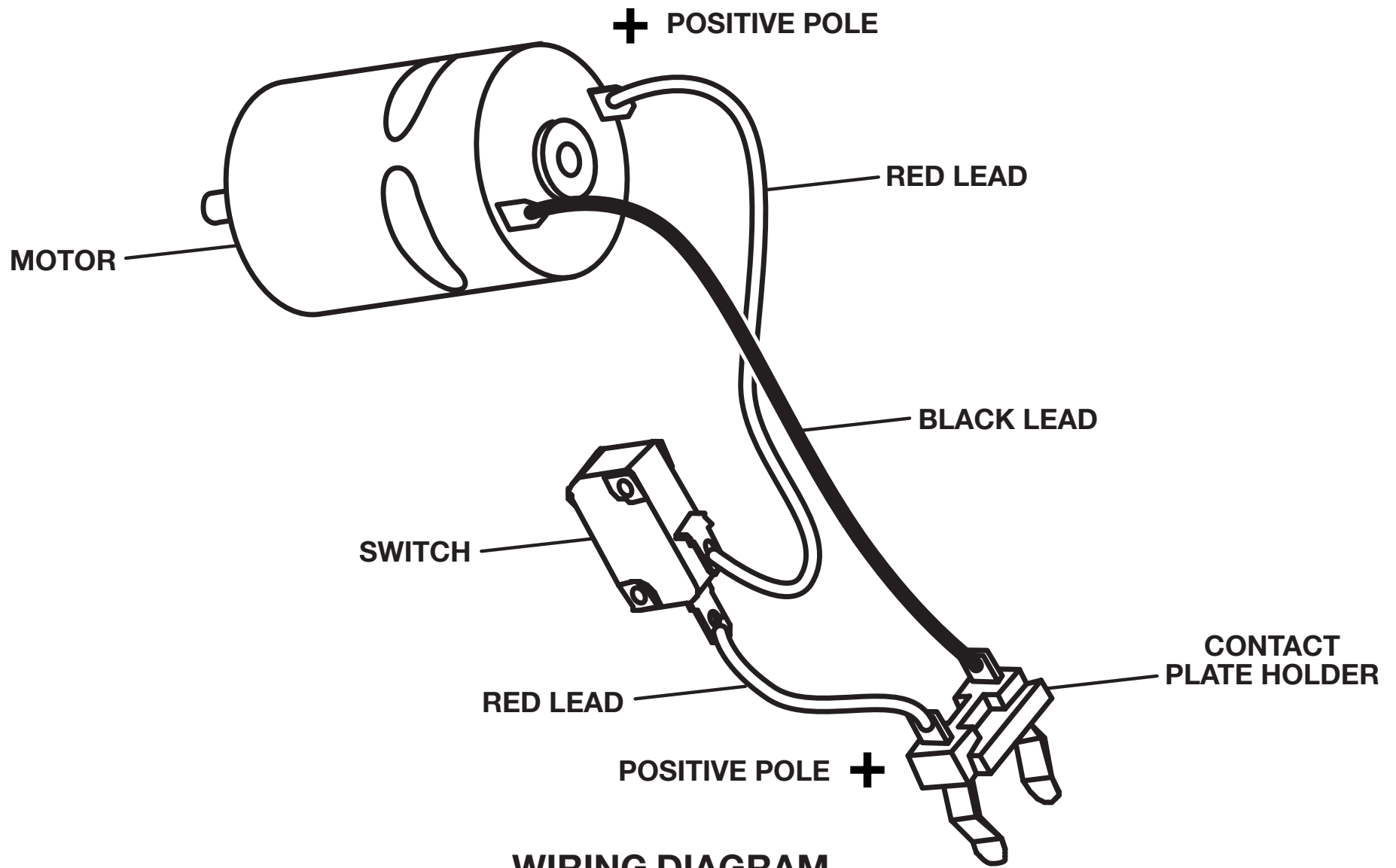

WIRING DIAGRAM