

Homelite®

PARTS LIST

String Trimmers / Brushcutters



F2030	UT20777
	UT20779
F3050	UT15179
ST525	UT15177

PART NO. PS03622

Non-Clutch
F2030 (UT20777, UT20779)

IGNITION - ROTOR - STARTER

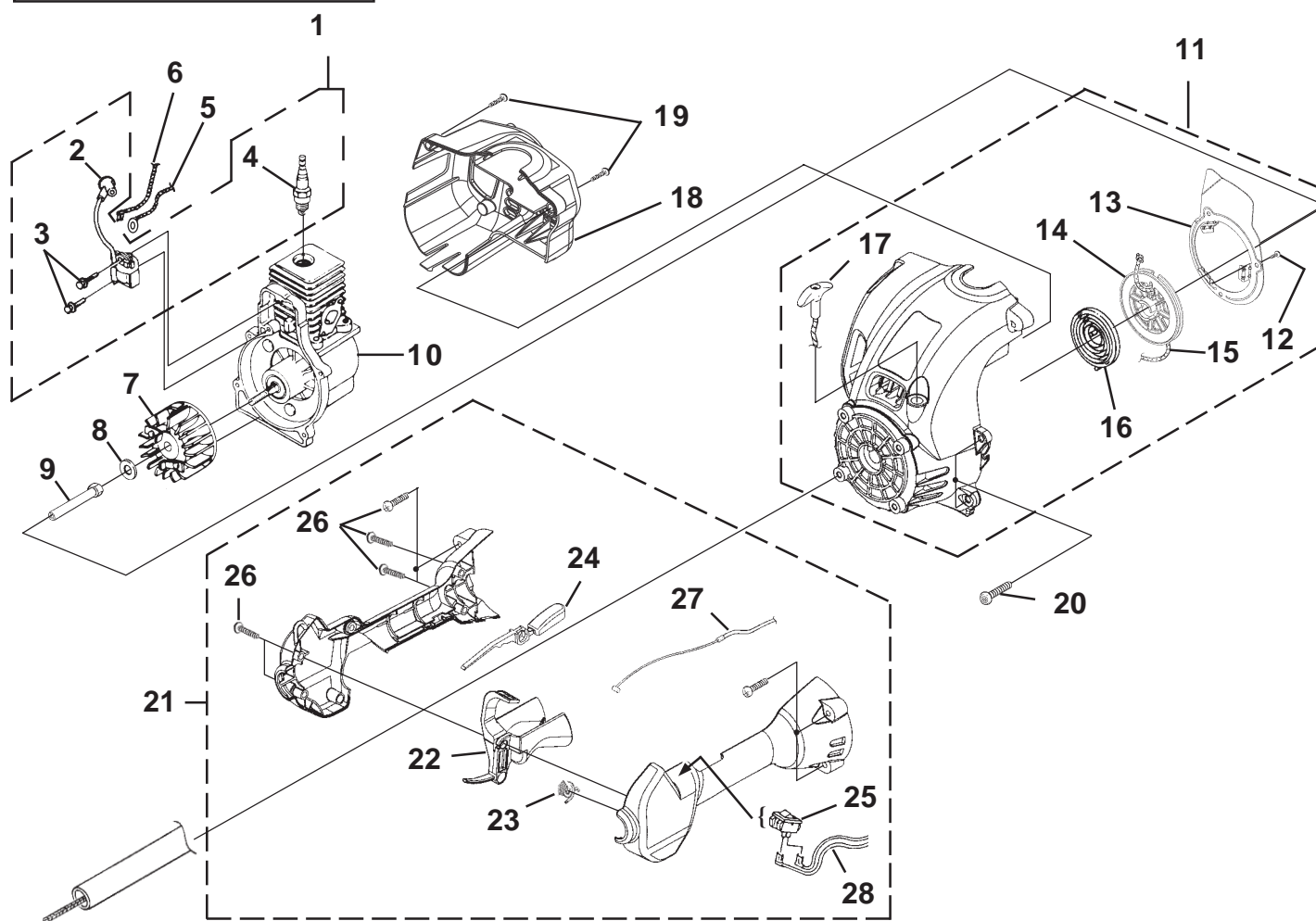

No.	Part No.	Description	Qty.
1	• A 07174	IGNITION KIT	1
2	UP 03868	TERMINAL & COVER	1
3	UP 03896	SCREW-Taptite (8-32 X 1")	2
4	UP 03883	SPARK PLUG (RDJ-7Y)	1
5	A 06964	LEAD-Electrical	1
6	A 06963	LEAD-Electrical	1
7	UP 03009	ROTOR KIT	1
8	UP 04241	WASHER-Flat	1
9	98795 A	CONNECTOR AND DRUM	1
10	UP 02994	SHORT BLOCK (See Engine Internal)	1
11	•UP 02962	COMPLETE STARTER ASSEMBLY	1
12	82543	SCREW-Thread Form (8-16 X 1/2")	3
13	UP 03013	BAFFLE-Air	1
14	UP 03012	PULLEY-Starter	1
15	UP 03912	ROPE-Starter (42")	1
16	UP 03917	SPRING & CONTAINER	1
17	UP 03026	GRIP-Starter (Yellow)	1
18	•UP 02965	HOUSING-Rear Kit	1
19	UP 03895	SCREW-Plastite (10-14 X 3/4")	2
20	UP 03406	SCREW-Taptite (10-24 X 3/4")	4

No.	Part No.	Description	Qty.
21	• UP 03114	CONTROL HANDLE ASSY.	1
22	• UP 03207	TRIGGER-Throttle	1
23	UP 03210	SPRING	1
24	UP 03173	THROTTLE INTERLOCK	1
25	UP 04197	SWITCH	1
26	UP 04247	SCREW-Taptite (10-14 X 1")	9
27	UP 03172	CABLE-Throttle	1
28	UP 03174	LEAD-Electrical	1

Torque Specs			
Item No.	In/Lbs	Nm	Required Loctite
3	30-40	3.4-4.5	Blue 242
4	120-180	13.6-20.3	
12	10-20	1.1-2.3	
19	30-50	3.4-5.6	
20	30-40	3.4-4.5	
26	30-50	3.4-5.6	

Warranty Flat Rate		
Job	Description	Time/Hr.
FA11	Ignition Mod.	.3
FA12	Ground Lead	.3
FG10	Starter	.4
FD12	Engine Housing, Rear	.4
FF13	Trigger, Throttle cable	.3

Clutch
F3050 (UT15179)

IGNITION - ROTOR - STARTER - CLUTCH

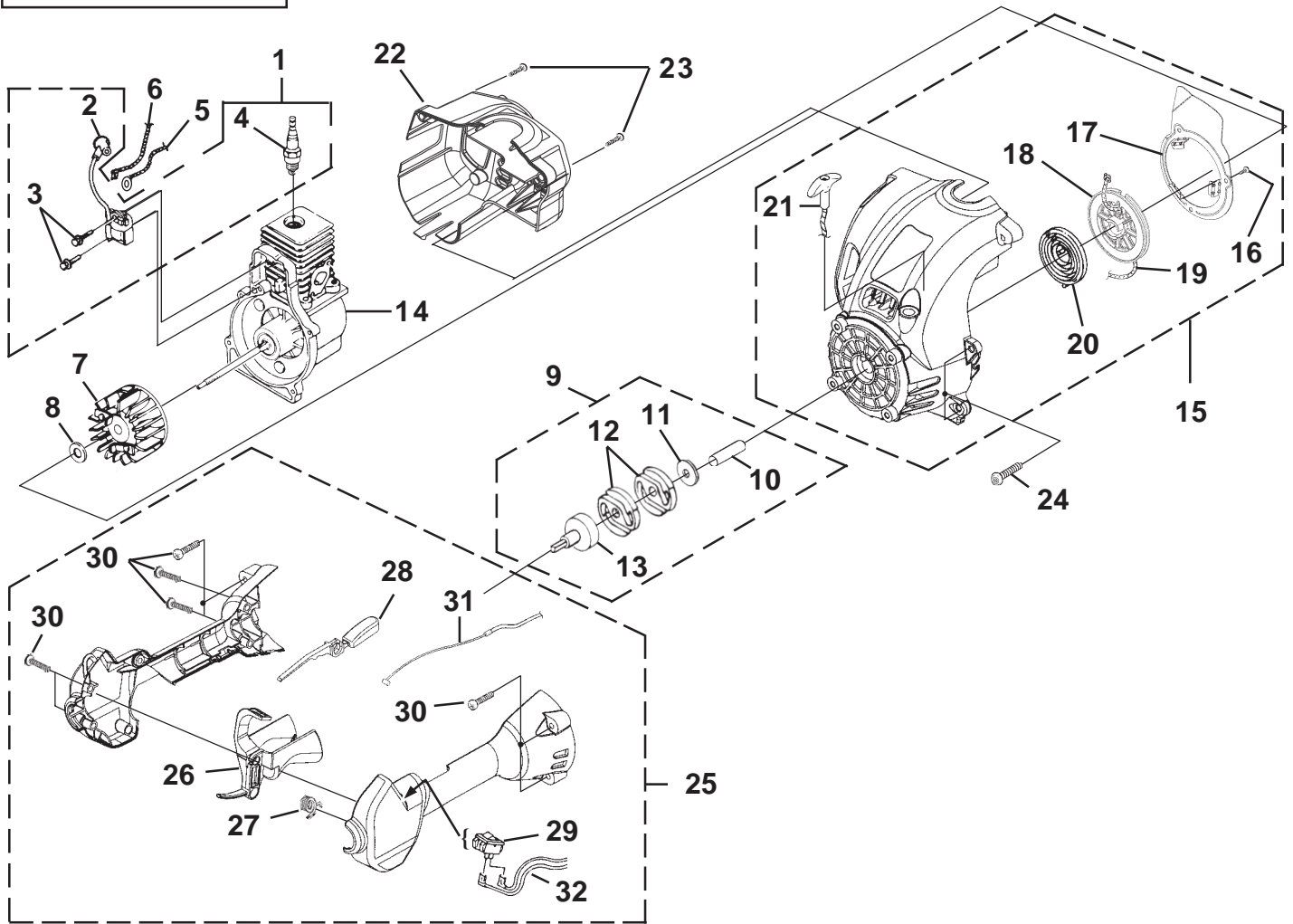

No.	Part No.	Description	Qty.
1	• A 07174	IGNITION KIT	1
2	UP 03868	TERMINAL & COVER	1
3	UP 03896	SCREW-Taptite (8-32 X 1")	2
4	UP 03883	SPARK PLUG	1
5	A 06964	LEAD-Electrical	1
6	A 06963	LEAD-Electrical	1
7	UP 03009	ROTOR KIT	1
8	PS 84065	WASHER-Flat	1
9	•UP 00034	CLUTCH AND DRUM KIT	1
10	UP 04118	SPACER	1
11	98929 A	WASHER-Flat	1
12	UP 04103	CLUTCH	2
13	A 02727	CONNECTOR AND DRUM	1
14	UP 02995	SHORT BLOCK (See Engine Internal)	1
15	•UP 02962	COMPLETE STARTER ASSEMBLY	1
16	82543	SCREW-Thread Form (8-16 X 1/2")	3
17	UP 03013	BAFFLE-Air	1
18	UP 03012	PULLEY-Starter	1
19	UP 03912	ROPE-Starter (42")	1
20	UP 03917	SPRING & CONTAINER	1
21	UP 03026	GRIP-Starter (Yellow)	1
22	•UP 02965	HOUSING-Rear Kit	1
23	UP 03895	SCREW-Plastite (10-14 X 7/8")	2
24	UP 03406	SCREW-Taptite (10-24 X 3/4")	4

No.	Part No.	Description	Qty.
25	•UP 03114	CONTROL HANDLE ASSY.	1
26	•UP 03207	TRIGGER-Throttle	1
27	UP 03210	SPRING	1
28	UP 03173	THROTTLE INTERLOCK	1
29	UP 04197	SWITCH	1
30	UP 04247	SCREW-Taptite (10-14 X 1")	9
31	UP 03172	CABLE-Throttle	1
32	UP 03174	LEAD-Electrical	1

Torque Specs			
Item No.	In/Lbs	Nm	Required Loctite
3	30-40	3.4-4.5	Blue 242
4	120-180	13.6-20.3	
16	10-20	1.1-2.3	
23	30-50	3.4-5.6	
24	30-40	3.4-4.5	
30	30-50	3.4-5.6	

Warranty Flat Rate		
Job	Description	Time/Hr.
FA11	Ignition Mod.	.3
FA12	Ground Lead	.3
FG10	Starter	.4
FD12	Engine Housing, Rear	.4
FF13	Trigger, Throttle cable	.3

3/1/2000

IGNITION - ROTOR - STARTER - CLUTCH

Clutch
ST525 (UT15177)

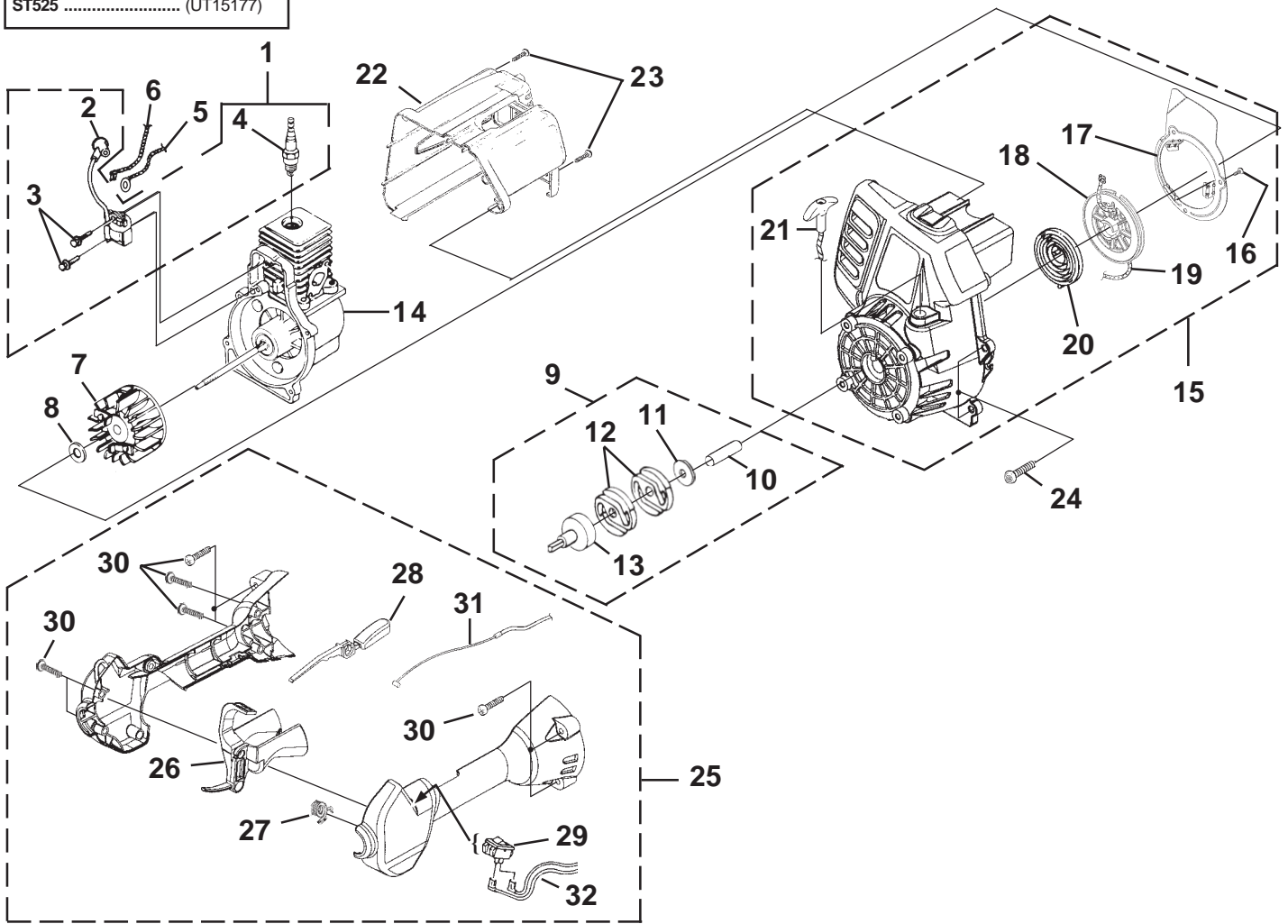

No.	Part No.	Description	Qty.
1	• A 07174	IGNITION KIT	1
2	UP 03868	TERMINAL & COVER	1
3	UP 03896	SCREW-Taptite (8-32 X 1")	2
4	UP 03883	SPARK PLUG	1
5	A 06964	LEAD-Electrical	1
6	A 06963	LEAD-Electrical	1
7	UP 03009	ROTOR KIT	1
8	PS 84065	WASHER-Flat	1
9	•UP 00034	CLUTCH AND DRUM KIT	1
10	UP 04118	SPACER	1
11	98929 A	WASHER-Flat	1
12	UP 04103	CLUTCH	2
13	A 02727	CONNECTOR AND DRUM	1
14	UP 02995	SHORT BLOCK (See Engine Internal)	1
15	•UP 02963	COMPLETE STARTER ASSEMBLY	1
16	82543	SCREW-Thread Form (8-16 X 1/2")	3
17	UP 03013	BAFFLE-Air	1
18	UP 03012	PULLEY-Starter	1
19	UP 03912	ROPE-Starter (42")	1
20	UP 03917	SPRING & CONTAINER	1
21	UP 03026	GRIP-Starter (Yellow)	1
22	•UP 02964	HOUSING-Rear Kit	1
23	UP 03900	SCREW-Plastite (10-14 X 3/4")	2
24	UP 03406	SCREW-Taptite (10-24 X 3/4")	4

No.	Part No.	Description	Qty.
25	•UP 03114	CONTROL HANDLE ASSY.	1
26	•UP 03207	TRIGGER-Throttle	1
27	UP 03210	SPRING	1
28	UP 03173	THROTTLE INTERLOCK	1
29	UP 04197	SWITCH	1
30	UP 04247	SCREW-Taptite (10-14 X 1")	9
31	UP 03172	CABLE-Throttle	1
32	UP 03174	LEAD-Electrical	1

Torque Specs			
Item No.	In/Lbs	Nm	Required Loctite
3	30-40	3.4-4.5	Blue 242
4	120-180	13.6-20.3	
16	10-20	1.1-2.3	
23	30-50	3.4-5.6	
24	30-40	3.4-4.5	
30	30-50	3.4-5.6	

Warranty Flat Rate		
Job	Description	Time/Hr.
FA11	Ignition Mod.	.3
FA12	Ground Lead	.3
FG10	Starter	.4
FD12	Engine Housing, Rear	.4
FF13	Trigger, Throttle cable	.3

ENGINE INTERNAL

Non-Clutch	
F2030	(UT20777, UT20779)
Clutch	
F3050	(UT15179)
ST525	(UT15177)

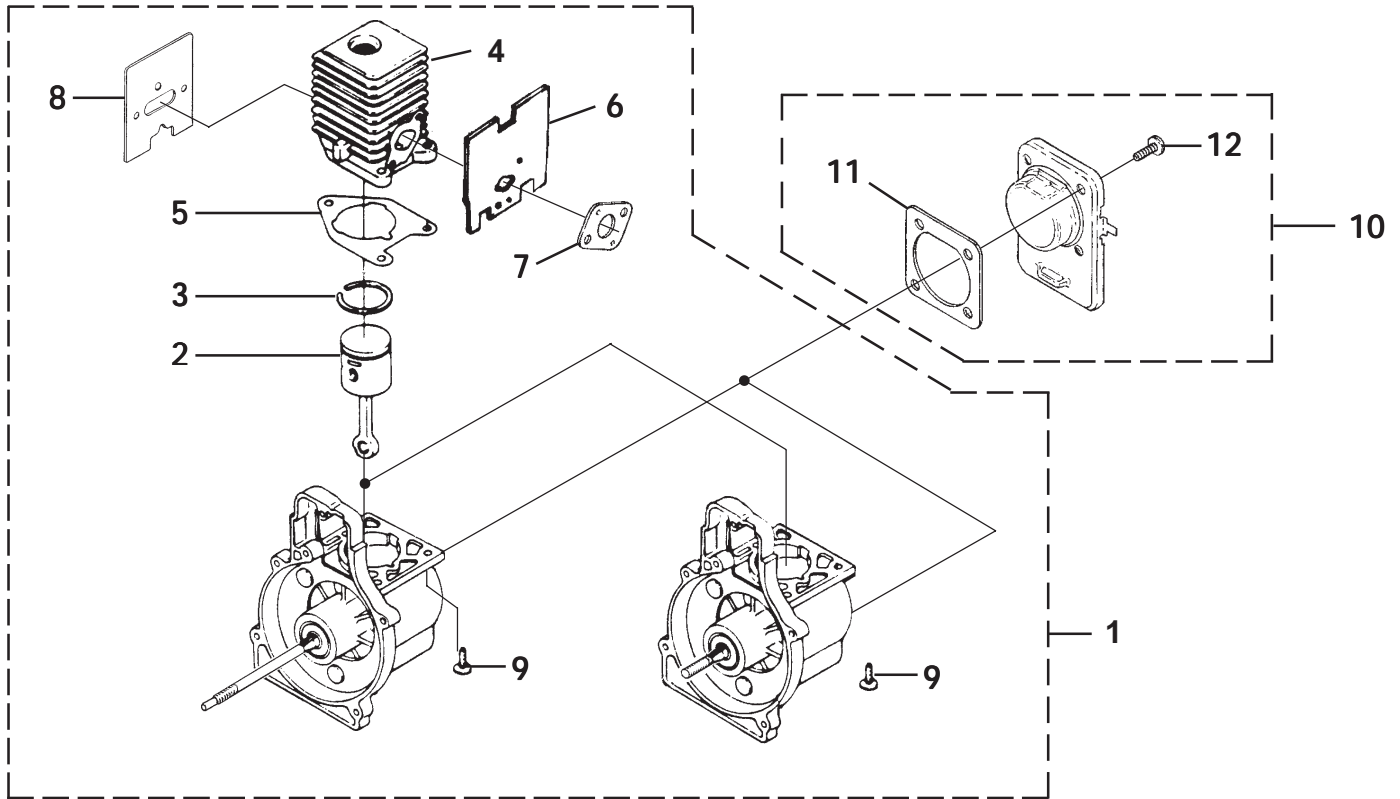

No.	Part No.	Description	Qty.
1	• UP 02994	SHORT BLOCK (Non-Clutch)	1
	• UP 02995	SHORT BLOCK (Clutch)	
2	• UP 00768	PISTON & ROD ASSY.	1
3	UP 03838	RING-Piston	1
4	• UP 04136	CYLINDER ASSY.	1
5	UP 03857	GASKET-Cylinder	1
6	UP 04308	GASKET-Heat Dam	1
7	UP 03916	GASKET-Carburetor	1
8	09343	GASKET-Muffler	1
9	UP 04345	SCREW-Sems (12-24 X 3/4")	3
10	• UP 00019	CRANKCASE COVER ASSEMBLY	1
11	UP 04335	GASKET-Crankcase Cover (Also included w/short block)	1
12	UP 04295	SCREW-Sems (10-24 X 1/2")	4

Item No.	Torque Specs		Required Loctite
	In/Lbs	Nm	
9	55-65	6.2-7.3	Red 262
12	35-45	4.0-5.1	Red 262

Warranty Flat Rate		
Job	Description	Time/Hr.
FB10	Partial Rebuild	1.0
FB20	Short Block	1.0
FD25	Crankcase Cover	.3

CARBURETOR - FUEL TANK

Non-Clutch	
F2030	(UT20777, UT20779)
Clutch	
F3050	(UT15179)
ST525	(UT15177)

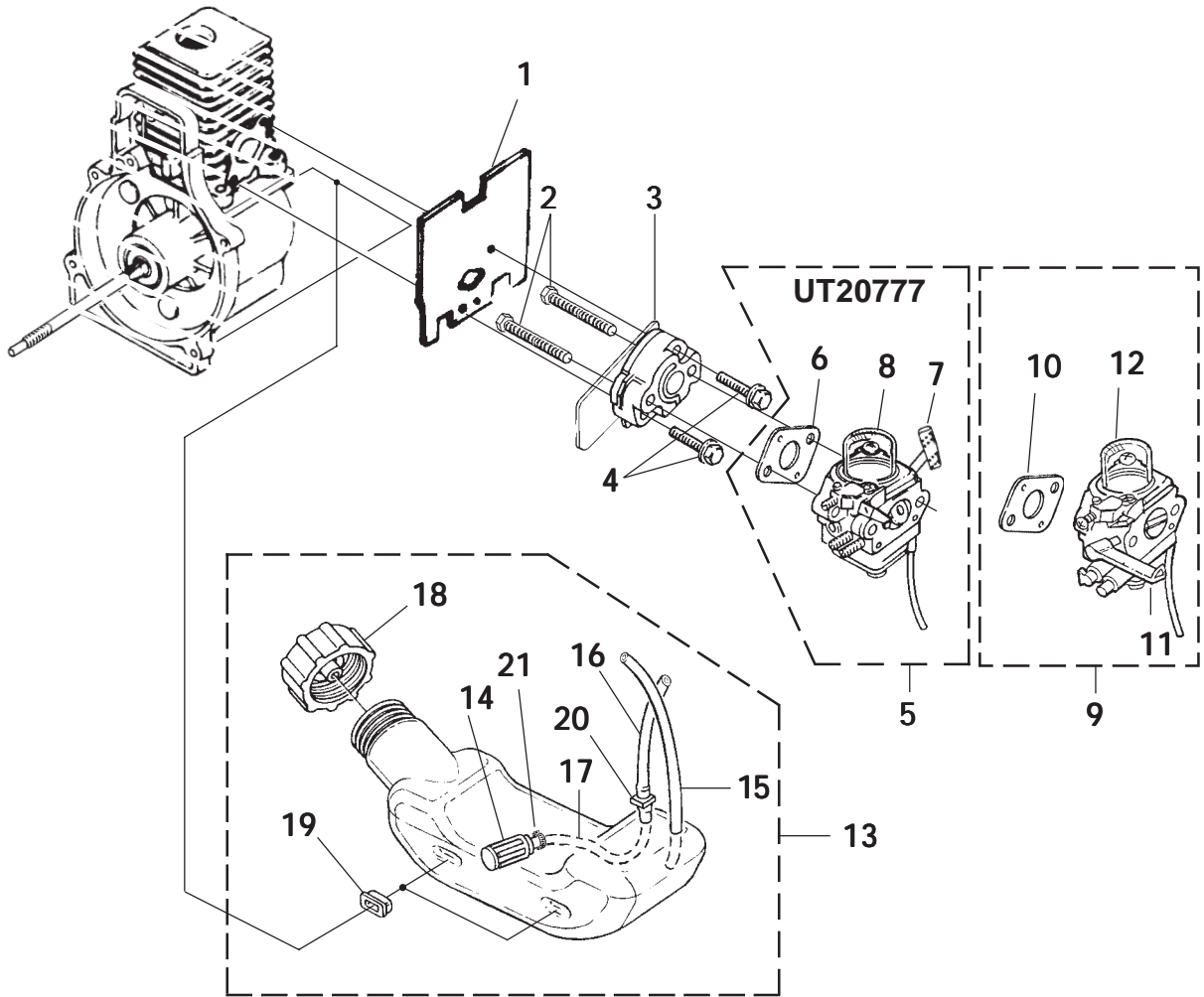

No.	Part No.	Description	Qty.
1	UP 04308	GASKET-Heat Dam	1
2	UP 04131	SCREW-Machine (10-24 X 2 1/4")	2
3	UP 04348	HEAT DAM	1
4	UP 04140	SCREW-Sems (10-24 X 1")	2
5	•UP 00608	CARBURETOR KIT (UT20777)	1
6	UP 03916	GASKET-Carburetor	1
7	UP 04278	Lever-Choke (Zama)	1
8	A 01195 A	Bulb-Primer	1
9	•UP 04742	CARBURETOR KIT (Non Clutch)	1
	UP 05085	CARBURETOR KIT (Clutch)	1
10	UP 03916	GASKET-Carburetor	1
11	UP 04740	Lever-Choke	1
12	A 01195 A	Bulb-Primer	1
13	•UP 00020	FUEL TANK ASSY.	1
14	UP 03871	FILTER-Fuel	1
15	UP 04293	TUBING-Rubber	1
16	UP 04292	TUBING-Rubber	1
17	UP 04715	TUBING-Rubber	1
18	UP 00106	FUEL CAP	1
19	UP 03501	BUMPER-Rubber	3
20	UP 03831	FITTING-Inline	1
21	UP 03913	CLAMP	1

Torque Specs			
Item No.	In/Lbs	Nm	Required Loctite
4	35-45	4.0-5.1	Red 262

Warranty Flat Rate		
Job	Description	Time/Hr.
FF17	... Manifold	.3
FF10	... Carburetor Rep.	.3
FF16	... Fuel Tank	.3
FF12	... Fuel/Return Line	.3

MUFFLER - AIR CLEANER

Non-Clutch	
F2030	(UT20777, UT20779)
Clutch	
F3050	(UT15179)
ST525	(UT15177)

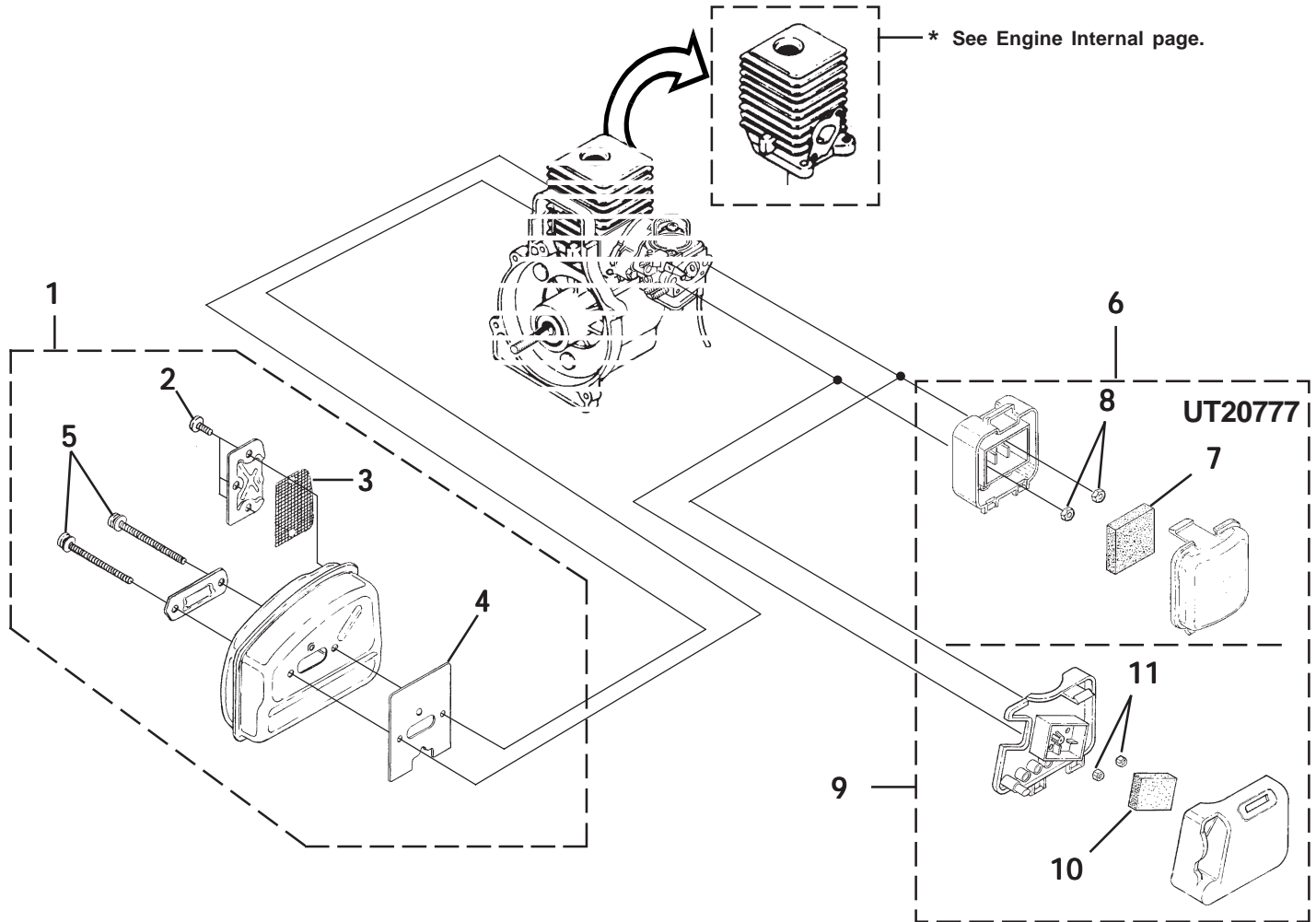

No.	Part No.	Description	Qty.
1	• UP 04634	MUFFLER ASSEMBLY	1
2	UP 04248	SCREW, Taptite- (8-32 X 3/8")	3
3	UP 04629	SCREEN-Spark	1
4	UP 04710	GASKET-Muffler	1
5	88083	SCREW, Truss Hd. - (10-24 X 2.188)	2
6	• UP 00022	AIR FILTER KIT (UT20777)	1
7	D 98760 B	FILTER-AIR	1
8	UP 03885	NUT-Hex (10-24)	2
9	• UP 05084	AIR FILTER KIT	1
10	D 98760 B	FILTER-AIR	1
11	UP 03885	NUT-Hex (10-24)	2

Torque Specs			
Item No.	In/Lbs	Nm	Required Loctite
2	25-35	2.8-4.0	
5	50-60	5.6-6.8	
8	30-40	3.4-4.5	
11	30-40	3.4-4.5	

Warranty Flat Rate		
Job	Description	Time/Hr.
FB18 ...	Muffler-Replace3
FF42 ...	Air Filter Assy.2

F2030 (UT20777, UT20779)

SHAFT - SPOOL & STRING - GRASS DEFLECTOR

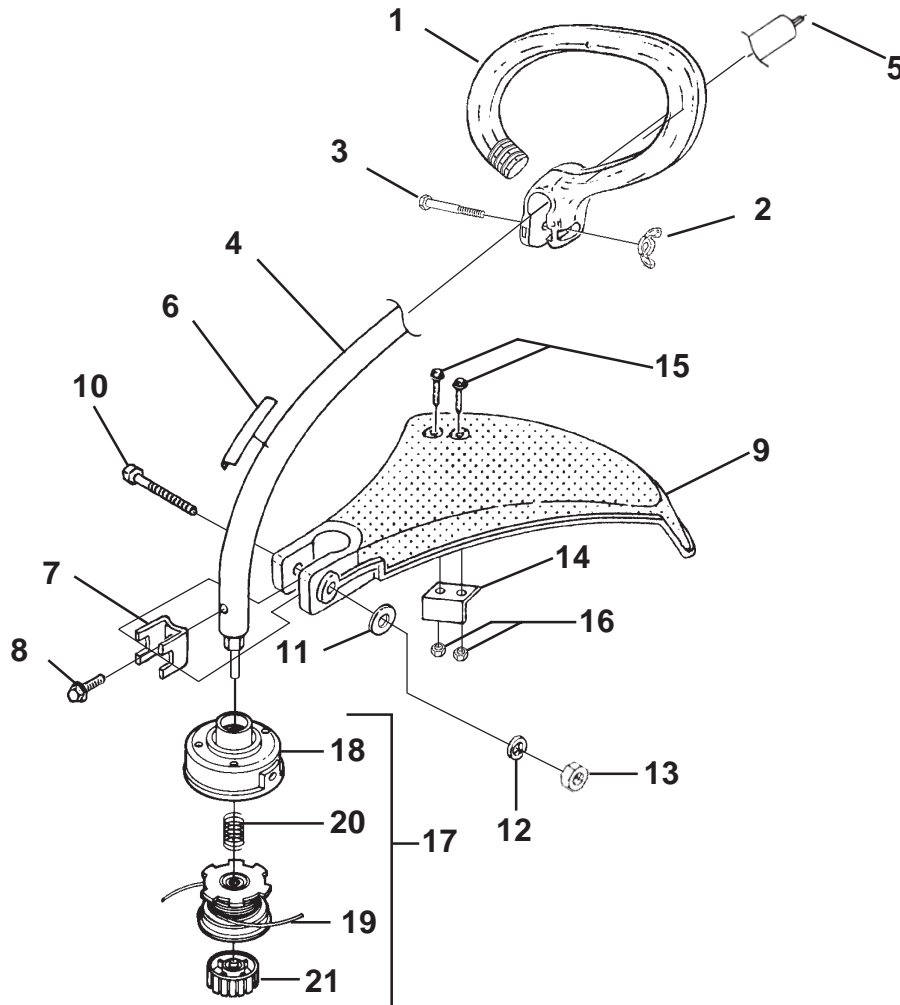

No.	Part No.	Description	Qty.
1	• A 07136	HANDLE ASSY-Front	1
2	93992	NUT-Wing, Washer Faced (1/4-20)	1
3	80295	SCREW-Cap Hex Hd.	1
4	•UP 04357	DRIVESHAFT HOUSING ASSY.	1
5	UP 03031	SHAFT-Flexible	1
6	UP 04352	DECAL-Warning	1
7	07928	CLAMP	1
8	88077	SCREW-Sems Hex Hd. (#10-24 X 3/8")	1
9	• A 04705	DEFLECTOR & BLADE KIT (55 Deg.)	1
10	80295	SCREW-Cap Hex Hd. (10-24 X 2")	1
11	UP 03415	WASHER-Flat (1/4")	1
12	UP 03409	WASHER-Lock (1/4")	1
13	UP 03399	NUT-Hex	1
14	•UP 04119	BLADE-Cut-Off	1
15	82531	SCREW-Mech. Hex Hd. (10-24 X 7/8")	2
16	UP 03885	NUT-Hex (10-24)	2

No.	Part No.	Description	Qty.
17	•DA 04591 A	STRINGHEAD-Complete	1
18	A 98231 A	HOUSING & EYELET (Dual Line)	1
19	•UP 00147	SPOOL & STRING (.095" Line)	1
20	B 06713	SPRING-Compression	1
21	DA 98866 A	RETAINER-Spool (R.H. Thread, Black)	1

Torque Specs			
Item No.	In/Lbs	Nm	Required Loctite
2	5-25	.6-2.8	
8	15-25	1.7-2.8	
15	5-25	.6-2.8	
16	30-40	3.4-4.5	

Warranty Flat Rate		
Job	Description	Time/Hr.
FM10	.. Stringhead Assy.2
FN12	... Driveshaft3
FN13	... Driveshaft Hsg.3
FN16	... Deflector-Grass2
FD20	... Front Handle2

ST525 (UT15177)

SHAFT - SPOOL & STRING - GRASS DEFLECTOR

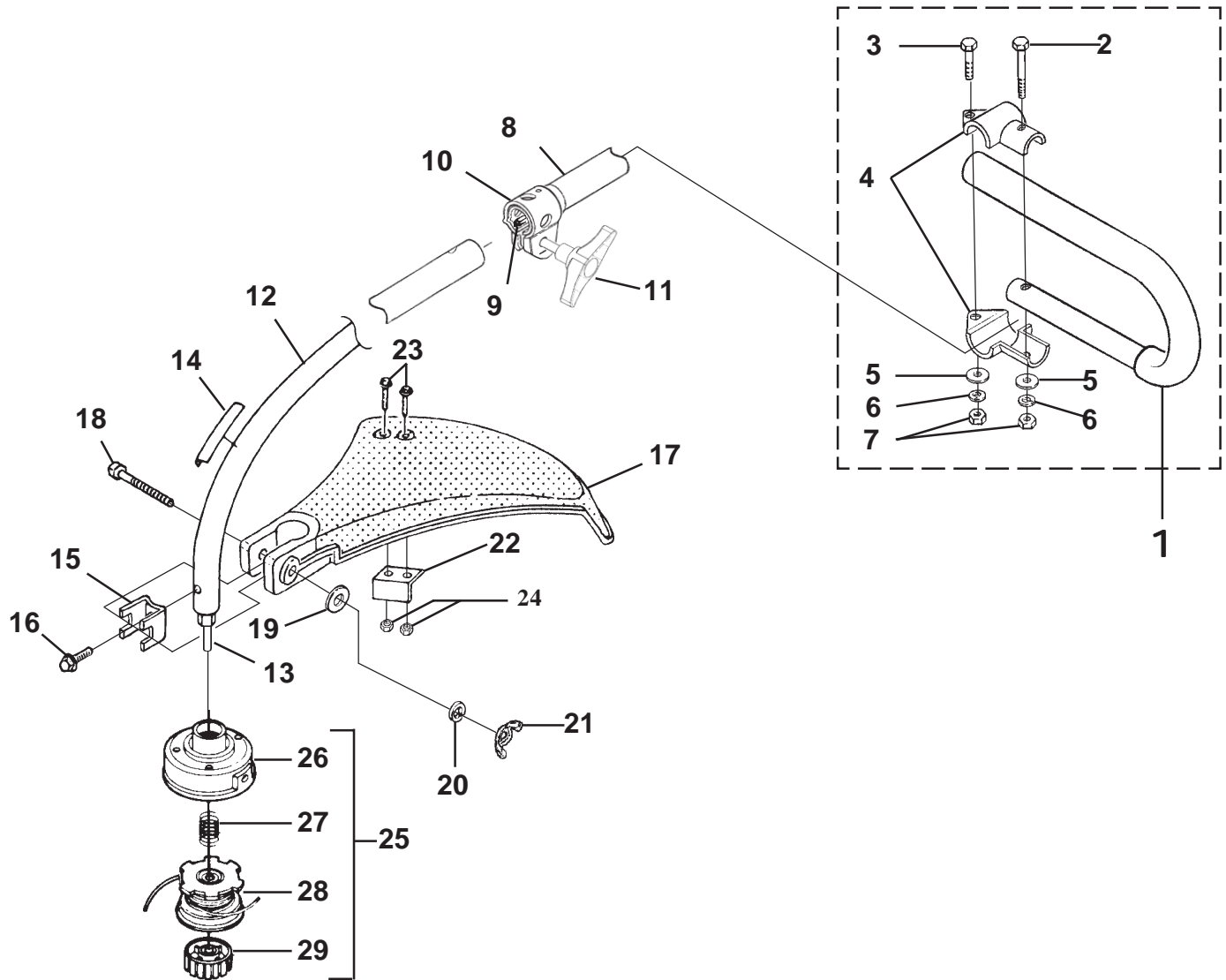

No.	Part No.	Description	Qty.
1	• A 07159	HANDLE("J")	1
2	UP 04154	SCREW-Hex Hd. (1/4-20 X 1 1/2")	1
3	UP 04158	SCREW-Hex Hd. (1/4-20 X 1")	1
4	UP 04105	CLAMP-Handle Bar	2
5	UP 04251	WASHER-Flat (1/4")	2
6	UP 03409	WASHER-Lock (1/4")	2
7	UP 03399	NUT-Hex (1/4-20)	2
8	• UP 05136	DRIVESHAFT ASSY. (Upper)	1
9	A 07667	FLEXSHAFT w/Collar & Liner	1
10	• UP 03839	COUPLER KIT	1
11	UP 05137	KNOB	1
12	• UP 03851	DRIVESHAFT HOUSING (Lower)	1
13	A 07673	SHAFT-Flex	1
14	PS 00038	DECAL-Warning	1
15	07928	CLAMP	1
16	88077	SCREW-Sems Hex (10-24 X 3/8")	1

No.	Part No.	Description	Qty.
17	• A 04705	DEFLECTOR & BLADE KIT (55 Deg.)	1
18	80295	SCREW-Cap Hex Hd. (1/4-20 X 2")	1
19	84006	WASHER-Flat (1/4")	1
20	83009	WASHER-Lock (1/4")	1
21	93992	NUT-Wing, Washer Faced (1/4-20)	1
22	• UP 04119	BLADE-Cut-Off	1
23	82531	SCREW-Mech. Hex Hd. (10-24 X 7/8")	2
24	81208	NUT-Hex (10-24)	2
25	• DA 04591 A	STRINGHEAD-Complete (.095")	1
26	A 98231 A	HOUSING & EYELET (Dual Line)	1
27	06713	SPRING-Compression	1
28	UP 00147	SPOOL & STRING (.095")	1
29	DA 98866 A	RETAINER-Spool (R.H. Thread, Black)	1

3/1/2000

F3050 (UT15179)

SHAFT - SPOOL & STRING - GRASS DEFLECTOR

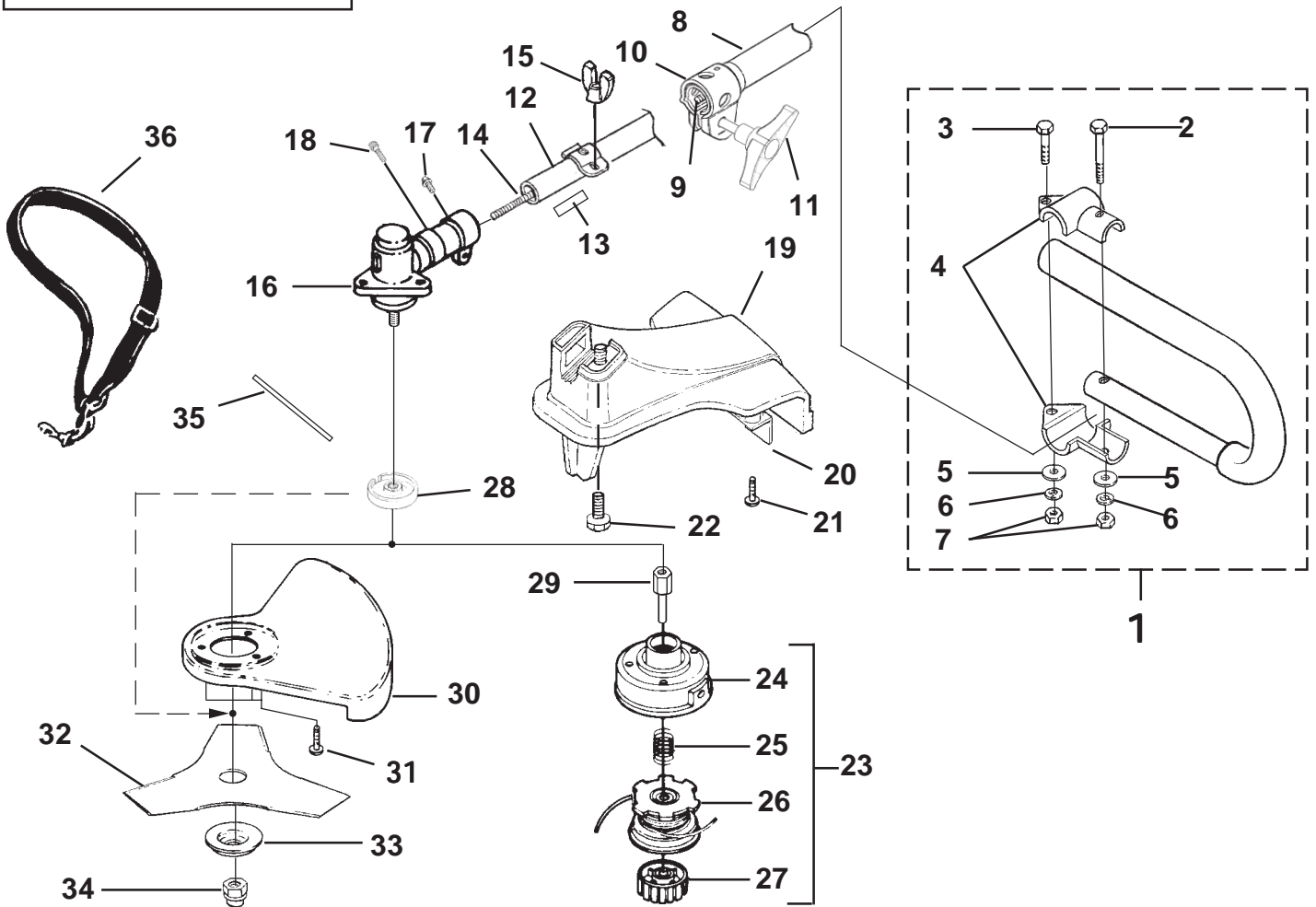

No.	Part No.	Description	Qty.
1	• A 07159	HANDLE("J")	1
2	UP 04154	SCREW-Hex Hd. (1/4-20 X 1 1/2")	1
3	UP 04158	SCREW-Hex Hd. (1/4-20 X 1")	1
4	UP 04105	CLAMP-Handle Bar	2
5	UP 04251	WASHER-Flat (1/4")	2
6	UP 03409	WASHER-Lock (1/4")	2
7	UP 03399	NUT-Hex (1/4-20)	2
8	• UP 05136	DRIVESHAFT HOUSING (Upper)	1
9	A 07667	FLEXSHAFT-w/Collar & Liner	1
10	• UP 03839	COUPLER KIT	1
11	UP 05137	KNOB	1
12	• UP 03956	DRIVESHAFT HOUSING (Lower)	1
13	UP 04116	DECAL-Warning	1
14	UP 04369	SHAFT-Flexible	1
15	UP 04893	WING NUT	1
16	• UP 04124	GEAR HEAD	1
17	82586	Screw, Cap Hd. (1/4-20 X 7/8")	5
18	UP 04254	Screw-Hex Hd. (10-24 x 1/2")	2
19	• A 05086	GRASS DEFLECTOR KIT	1
20	• UP 04890	BLADE-Cut-Off	1
21	UP 03898	SCREW, Thread Form. (10-24 X 3/4")	2
22	UP 04892	SCREW-Square Head	1
23	• DA 03174 A	STRINGHEAD-Complete (.095")	1
24	A 98231 A	HOUSING & EYELET (Dual Line)	1
25	B 06713	SPRING-Compression	1
26	UP 00147	SPOOL & STRING (.095")	1
27	UP 00104	RETAINER-Spool (L.H. Thread, Red)	1

No.	Part No.	Description	Qty.
28	UP 04126	WASHER-Flanged	1
29	98551 41	ADAPTER-Shaft	1
30	• UP 05070	BLADE GUARD	1
31	UP 04254	SCREW	3
32	D 98717 C	BLADE-Tri-Arc™	1
33	UP 04129	WASHER-Cupped (Lower)	1
34	UP 04127	NUT-Hex (L.H.)	1
35	UP 04100	TOOL-Holding Pin	1
36	UP 00108	HARNESS	1

Torque Specs			
Item No.	In/Lbs	Nm	Required Loctite
7	90-100	10.2-11.3	
12	15-20	1.7-2.3	
13	40-50	4.5-5.6	
17	30-50	3.4-5.6	
19	100-120	11.3-13.6	
21	40-60	4.5-6.8	
34	100-120	11.3-13.6	

Warranty Flat Rate		
Job	Description	Time/Hr.
FM10	.. Stringhead Assy.	.2
FN12	... Driveshaft (Upper)	.3
FN13	... Driveshaft Housing	.4
FN15	... Gearhead	.3
FN16	... Deflector	.3

For Parts Call 606-678-9623 or 606-561-4983

NOTES

For Parts Call 606-678-9623 or 606-561-4983

For product information, technical help, dealer locations or parts ordering information visit our website at:
www.homelite.com.

John Deere Consumer Products, Inc.
PO. Box 7047
Charlotte, NC 28241
tel: USA only - 1-800-242-4672 / fax: 1-704-588-0926

John Deere Consumer Products Limited
Produits consommateurs John Deere Limitée
1850-55e/th Avenue
Lachine, Québec, Canada H8T 3J5
tel: Canada only - 1-800-363-5715 / fax: Canada only - 1-800-665-1588

John Deere Consumer Products Europe B.V.
Haverstraat 24
2153 GB Nieuw Vennep
The Netherlands
tel: +31-252-687342 / fax: +31-252-687993

John Deere Consumer Products SARL
Rue du Paradis - BP 231 - Ormes
45144 Saint-Jean-De-La-Ruelle
Cedex, France
tel: 33-23-874-2630 / fax: 33-23-870-0279

John Deere Limited
A.C.N. 008 671 725
166-170 Magnesium Drive
Crestmead, Queensland 4132
Australia
tel: 61-7-3802-3222 / fax: 61-7-3803-6555

John Deere Consumer Products, Inc.

www.mymowerparts.com