

Homelite®

PARTS LIST

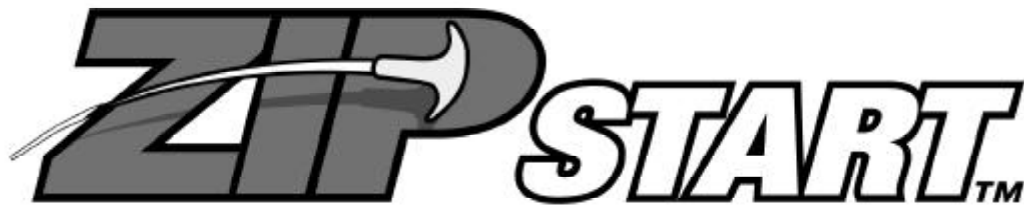

Trimmers/Brushcutters

EasyTrim™	UT20780		
d725cde	UT20773		
d825sd	UT20763,	UT20774,	UT20784
K400	UT15180,	UT15181	
VersaTool™	UT15164,	UT15169	
d825sb	UT15165,	UT15170	
BC2500R	UT15200		
ST2517CR	UT20817		
ST2537S	UT20818		

PART NO. PS04999

IGNITION - ROTOR - STARTER

Non-Clutch
 EasyTrim™ (UT20780)
 d825cde (UT20773)
 d825sd (UT20763, UT20774, UT20784)

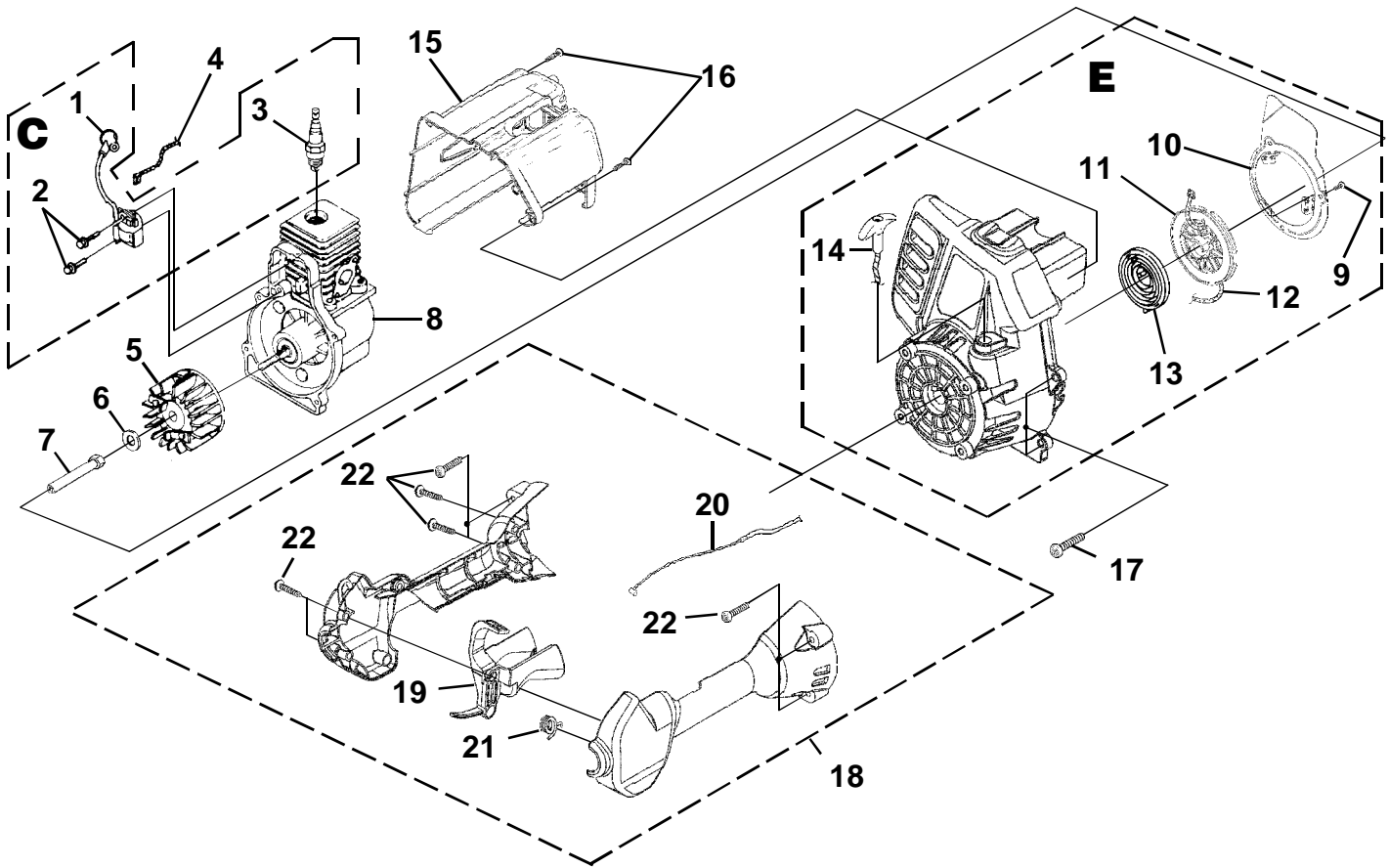

No.	Part No.	Description	Qty.
C	• A 07174	IGNITION KIT	1
1	UP 03868	TERMINAL & COVER	1
2	UP 03896	SCREW-Taptite (8-32 X 1")	2
3	UP 03883	SPARK PLUG	1
4	UP 04690	LEAD-Electrical	1
5	UP 03009	ROTOR KIT	1
6	UP 03906	WASHER-Flat	1
7	UP 04271	CONNECTOR-Drive (.250)	1
8	UP 02994	SHORT BLOCK (See Engine Internal)	1
E	•UP 02963	COMPLETE STARTER ASSEMBLY	1
9	UP 04164	SCREW-Thread Form (8-16 X 1/2")	3
10	UP 03013	BAFFLE-Air	1
11	UP 03012	PULLEY-Starter	1
12	UP 03912	ROPE-Starter (42")	1
13	UP 03917	SPRING & CONTAINER	1
14	UP 03026	GRIP-Starter (Yellow)	1
15	•UP 02964	HOUSING-Rear Kit	1
16	UP 03900	SCREW-Taptite (10-14 X 3/4")	2
17	UP 03406	SCREW-Taptite (10-24 X 3/4")	4
18	•UP 03113	CONTROL HANDLE ASSY.	1
19	UP 03207	TRIGGER	1
20	UP 03172	CABLE-Throttle	1
21	UP 03210	SPRING	1
22	UP 04247	SCREW-Truss Hd. (10-14 x 1")	9

Torque Specs			
Item No.	In/Lbs	Nm	Required Loctite
2	30-40	3.4-4.5	Blue 242
3	120-180	13.6-20.3	
7	100-150	11.3-16.9	
9	10-20	1.1-2.3	
16	30-50	3.4-5.6	
17	30-40	3.4-4.5	
22	30-50	3.4-5.6	

Warranty Flat Rate		
Job	Description	Time/Hr.
FA11	Ignition Mod.	.3
FA12	Ground Lead	.3
FG10	Starter	.4
FD12	Engine Housing, Rear	.4
FF13	Trigger, Throttle cable	.3

Clutch
d825sb (UT15165, UT15170)

IGNITION - ROTOR - STARTER - CLUTCH

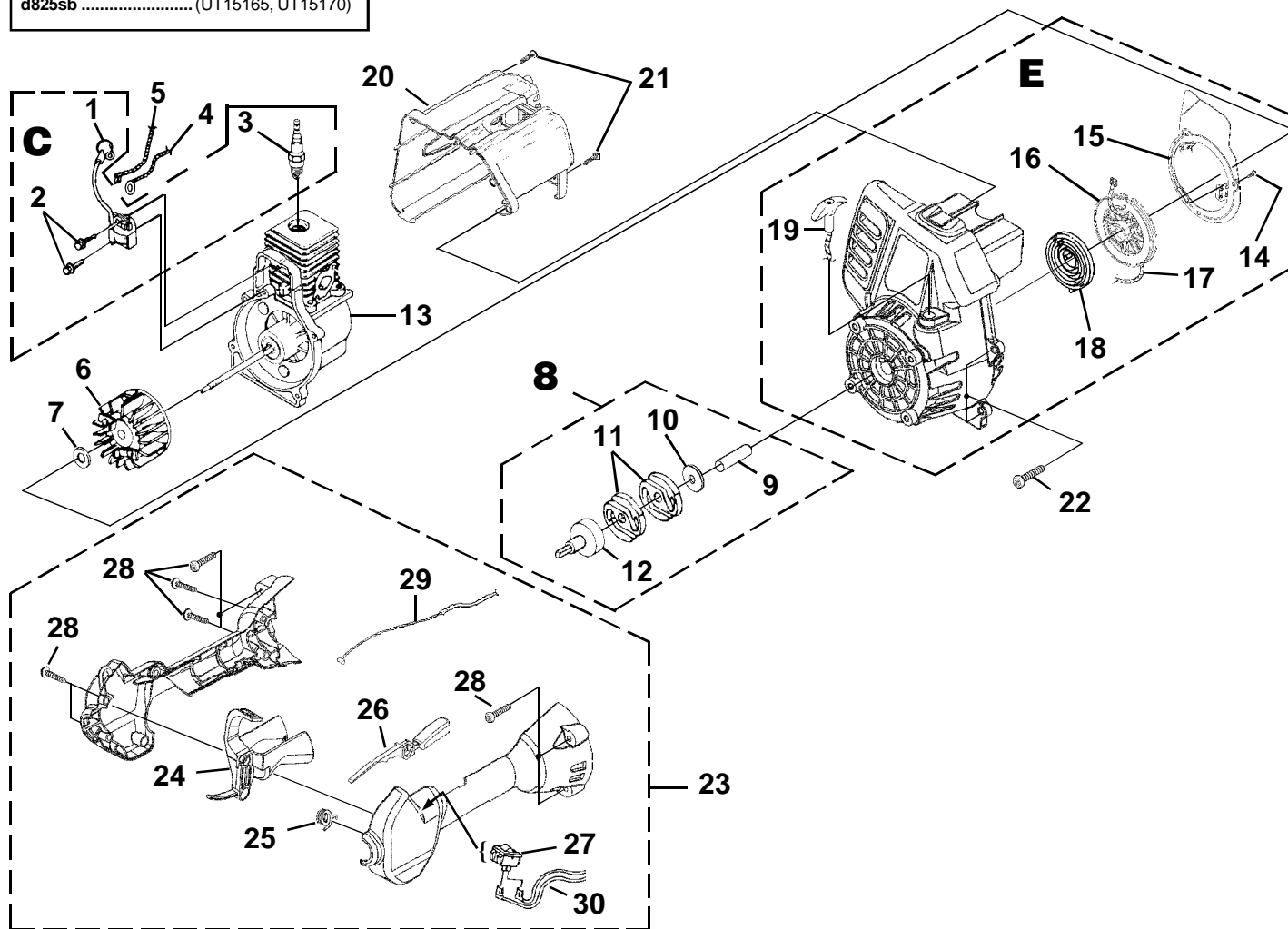

No.	Part No.	Description	Qty.
C	• A 07174	IGNITION KIT	1
1	UP 03868	TERMINAL & COVER	1
2	UP 03896	SCREW-Taptite (8-32 X 1")	2
3	UP 03883	SPARK PLUG	1
4	UP 04537	LEAD-Electrical	1
5	UP 04536	LEAD-Electrical	1
6	UP 03009	ROTOR KIT	1
7	UP 04241	WASHER-Flat	1
8	•UP 00034	CLUTCH AND DRUM KIT	1
9	UP 04118	SPACER	1
10	UP 04275	WASHER-Flat	1
11	UP 04103	CLUTCH	2
12	UP 04104	CONNECTOR AND DRUM	1
13	UP 02995	SHORT BLOCK (See Engine Internal)	1
E	•UP 02963	COMPLETE STARTER ASSEMBLY	1
14	UP 04164	SCREW-Thread Form (8-16 X 1/2")	3
15	UP 03013	BAFFLE-Air	1
16	UP 03012	PULLEY-Starter	1
17	UP 03912	ROPE-Starter (42")	1
18	UP 03917	SPRING & CONTAINER	1
19	UP 03026	GRIP-Starter (Yellow)	1
20	•UP 02964	HOUSING-Rear Kit	1
21	UP 03900	SCREW-Plastite (10-14 X 3/4")	2
22	UP 03406	SCREW-Taptite (10-24 X 3/4")	4

No.	Part No.	Description	Qty.
23	•UP 03114	CONTROL HANDLE ASSY.	1
24	•UP 03207	TRIGGER-Throttle	1
25	UP 03210	SPRING	1
26	UP 03173	THROTTLE INTERLOCK	1
27	UP 04197	SWITCH	1
28	UP 04247	SCREW-Taptite (10-14 X 1")	9
29	UP 03172	CABLE-Throttle	1
30	UP 03174	LEAD-Electrical	1

Torque Specs			
Item No.	In/Lbs	Nm	Required Loctite
2	30-40	3.4-4.5	Blue 242
3	120-180	13.6-20.3	
14	10-20	1.1-2.3	
21	30-50	3.4-5.6	
22	30-40	3.4-4.5	
28	30-50	3.4-5.6	

Warranty Flat Rate		
Job	Description	Time/Hr.
FA11	Ignition Mod.	.3
FA12	Ground Lead	.3
FG10	Starter	.4
FD12	Engine Housing, Rear	.4
FF13	Trigger, Throttle cable	.3

3/8/2001

IGNITION - ROTOR - STARTER

Non-Clutch

ST2517CR(UT20817)
ST2537S(UT20818)

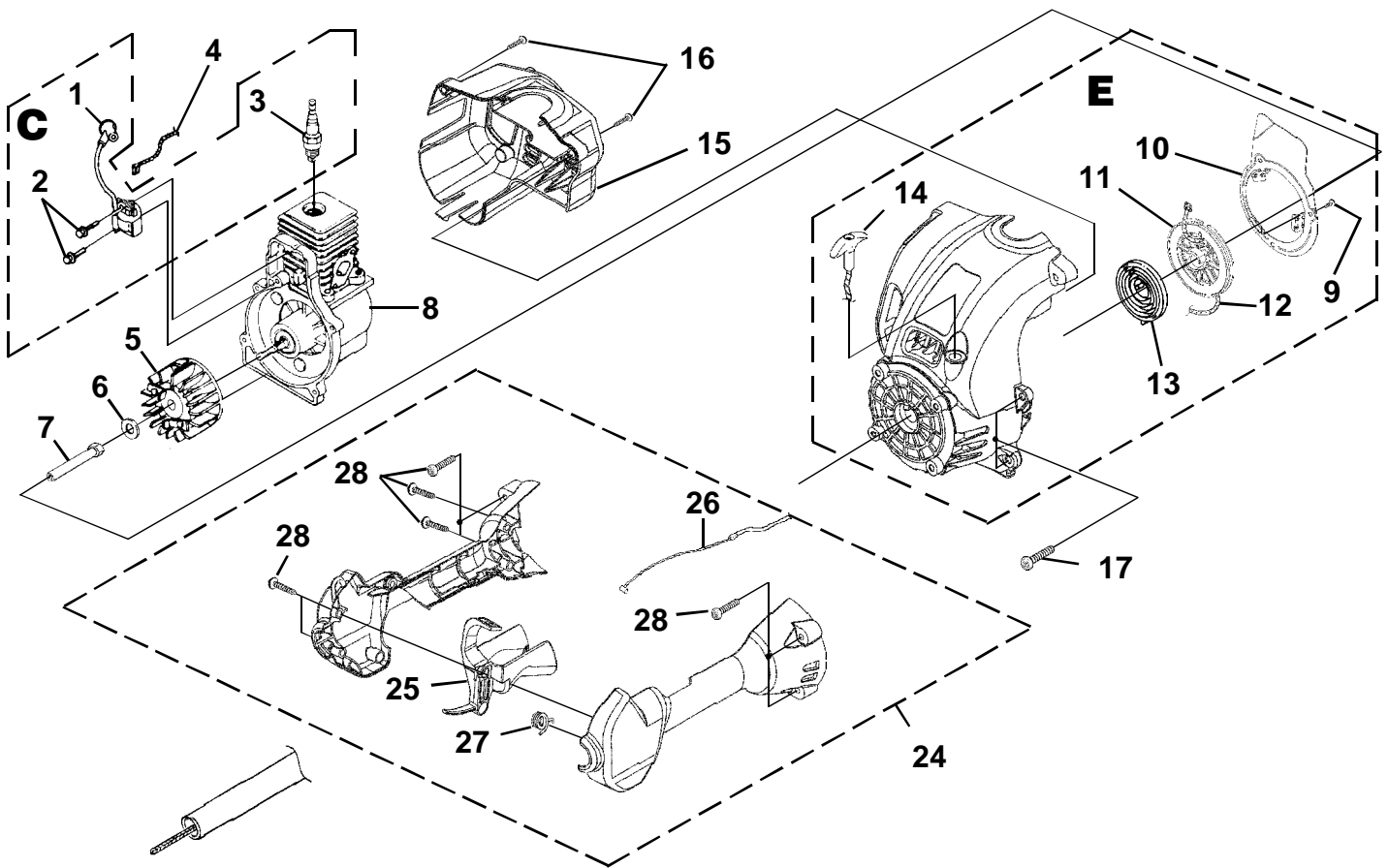

No.	Part No.	Description	Qty.
C	• A 07174	IGNITION KIT	1
1	UP 03868	TERMINAL & COVER	1
2	UP 03896	SCREW-Taptite (8-32 X 1")	2
3	UP 03883	SPARK PLUG	1
4	UP 04690	LEAD-Electrical	1
5	UP 03009	ROTOR KIT	1
6	UP 03906	WASHER-Flat	1
7	UP 04271	CONNECTOR-Drive (.250)	1
8	UP 02994	SHORT BLOCK (See Engine Internal)	1
E	•UP 02962	COMPLETE STARTER ASSEMBLY	1
9	UP 04164	SCREW-Thread Form (8-16 X 1/2")	3
10	UP 03013	BAFFLE-Air	1
11	UP 03012	PULLEY-Starter	1
12	UP 03912	ROPE-Starter (42")	1
13	UP 03917	SPRING & CONTAINER	1
14	UP 03026	GRIP-Starter (Yellow)	1
15	•UP 02965	HOUSING-Rear Kit	1
16	UP 03895	SCREW-Taptite (10-14 X 7/8")	2
17	UP 03406	SCREW-Taptite (10-24 X 3/4")	4
18	•UP 03113	CONTROL HANDLE ASSY.	1
19	UP 03207	TRIGGER	1
20	UP 03172	CABLE-Throttle	1
21	UP 03210	SPRING	1
22	UP 04247	SCREW-Truss Hd. (10-14 x 1")	9

Item No.	Torque Specs		Required Loctite
	In/Lbs	Nm	
2	30-40	3.4-4.5	Blue 242
3	120-180	13.6-20.3	
7	100-150	11.3-16.9	
9	10-20	1.1-2.3	
16	30-50	3.4-5.6	
17	30-40	3.4-4.5	
22	30-50	3.4-5.6	

Warranty Flat Rate		
Job	Description	Time/Hr.
FA11	Ignition Mod.	.3
FA12	Ground Lead	.3
FG10	Starter	.4
FD12	Engine Housing, Rear	.4
FF13	Trigger, Throttle cable	.3

IGNITION - ROTOR - STARTER - CLUTCH

Clutch
 K400 (UT15180, UT15181)
 VersaTool™ (UT15164, UT15169)
 BC2500R (UT15200)

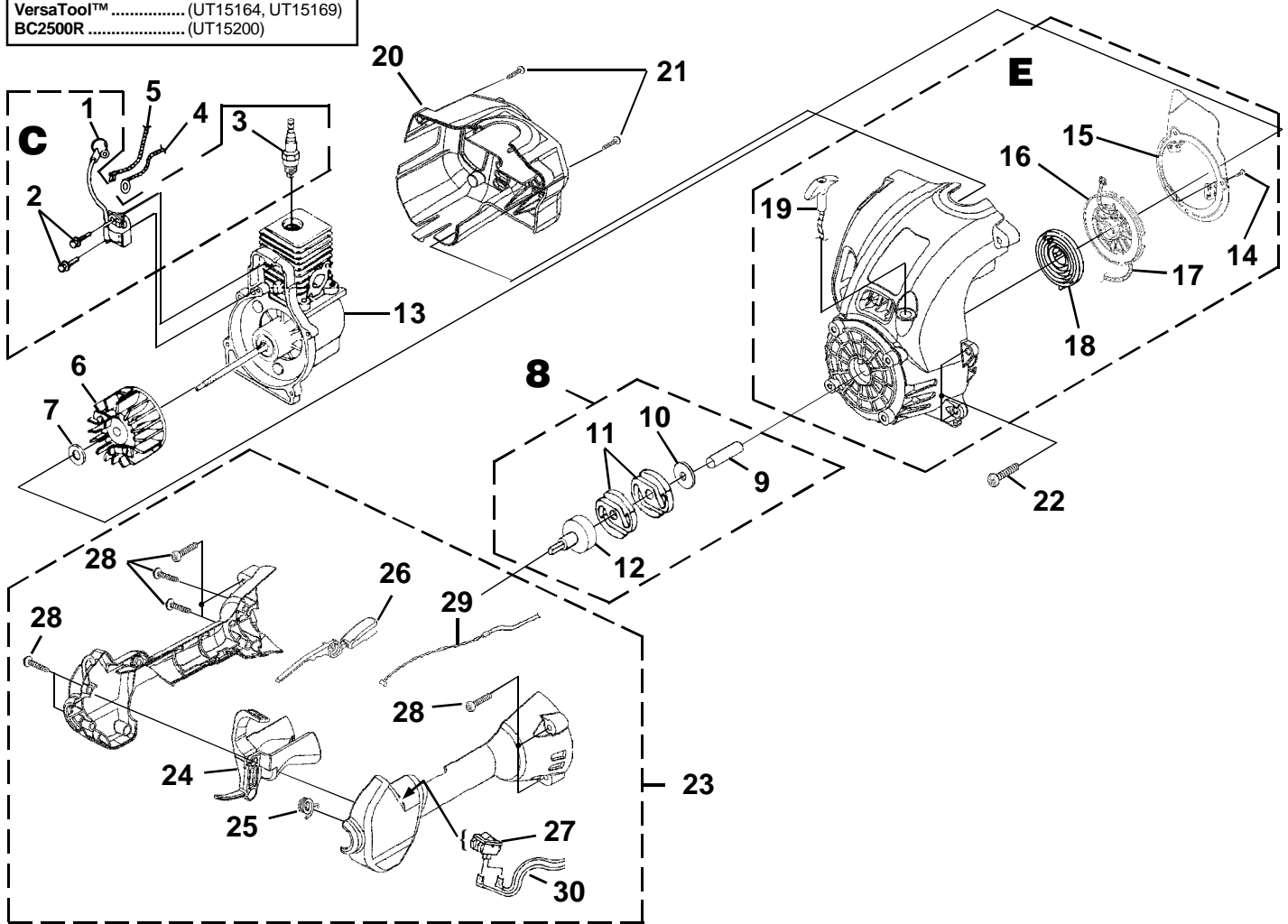

No.	Part No.	Description	Qty.
C	• A 07174	IGNITION KIT	1
1	UP 03868	TERMINAL & COVER	1
2	UP 03896	SCREW-Taptite (8-32 X 1")	2
3	UP 03883	SPARK PLUG	1
4	UP 04537	LEAD-Electrical	1
5	UP 04536	LEAD-Electrical	1
6	UP 03009	ROTOR KIT	1
7	UP 04241	WASHER-Flat	1
8	•UP 00034	CLUTCH AND DRUM KIT	1
9	UP 04118	SPACER	1
10	UP 04275	WASHER-Flat	1
11	UP 04103	CLUTCH	2
12	UP 04103	CONNECTOR AND DRUM	1
13	UP 02995	SHORT BLOCK (See Engine Internal)	1
E	•UP 02962	COMPLETE STARTER ASSEMBLY	1
14	UP 04164	SCREW-Thread Form (8-16 X 1/2")	3
15	UP 03013	BAFFLE-Air	1
16	UP 03012	PULLEY-Starter	1
17	UP 03912	ROPE-Starter (42")	1
18	UP 03917	SPRING & CONTAINER	1
19	UP 03026	GRIP-Starter (Yellow)	1
20	•UP 02965	HOUSING-Rear Kit	1
21	UP 03895	SCREW-Plastite (10-14 X 7/8")	2
22	UP 03406	SCREW-Taptite (10-24 X 3/4")	4

No.	Part No.	Description	Qty.
23	•UP 03114	CONTROL HANDLE ASSY.	1
24	•UP 03207	TRIGGER-Throttle	1
25	UP 03210	SPRING	1
26	UP 03173	THROTTLE INTERLOCK	1
27	UP 04197	SWITCH	1
28	UP 04247	SCREW-Taptite (10-14 X 1")	9
29	UP 03172	CABLE-Throttle	1
30	UP 03174	LEAD-Electrical	1

Torque Specs			
Item No.	In/Lbs	Nm	Required Loctite
2	30-40	3.4-4.5	Blue 242
3	120-180	13.6-20.3	
14	10-20	1.1-2.3	
21	30-50	3.4-5.6	
22	30-40	3.4-4.5	
28	30-50	3.4-5.6	

Warranty Flat Rate		
Job	Description	Time/Hr.
FA11	Ignition Mod.	.3
FA12	Ground Lead	.3
FG10	Starter	.4
FD12	Engine Housing, Rear	.4
FF13	Trigger, Throttle cable	.3

3/7/2000

ENGINE INTERNAL

Non-Clutch	
EasyTrim™	(UT20780)
d825cde	(UT20773)
d825sd	(UT20763, UT20774, UT20784)
ST2517CR	(UT20817)
ST2537S	(UT20818)
Clutch	
d825sb	(UT15165, UT15170)
K400	(UT15180, UT15181)
VersaTool™	(UT15164, UT15169)
BC2500R	(UT15200)

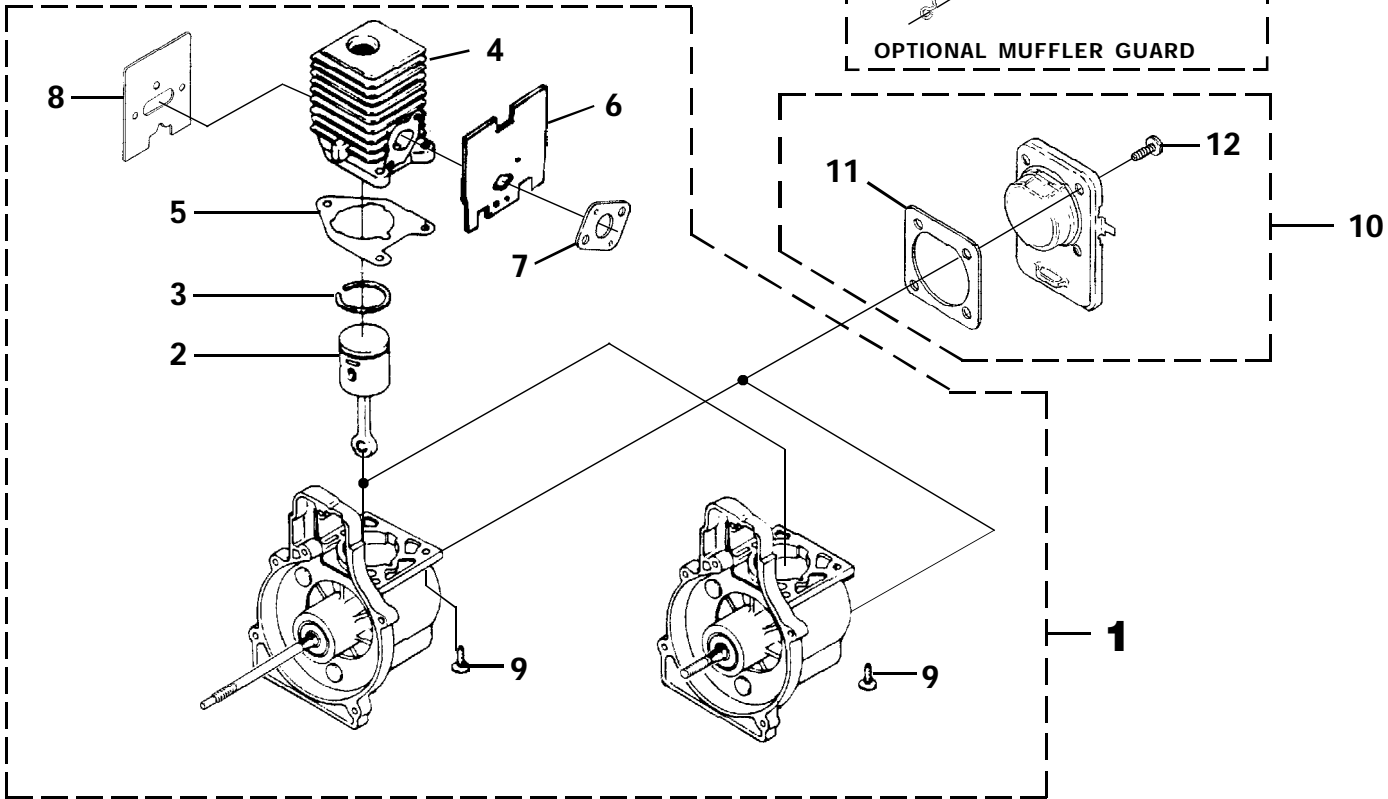

No.	Part No.	Description	Qty.
1	• UP 02994	SHORT BLOCK (Non-Clutch)	1
	• UP 02995	SHORT BLOCK (Clutch)	1
2	• UP 00768	PISTON & ROD ASSY.	1
3	UP 03838	RING-Piston	1
4	• UP 04136	CYLINDER ASSY.	1
5	UP 03857	GASKET-Cylinder	1
6	UP 04308	GASKET-Heat Dam	1
7	UP 03916	GASKET-Carburetor	1
8	UP 04710	GASKET-Muffler	1
9	UP 04345	SCREW-Sems (12-24 X 3/4")	3
10	• UP 00019	CRANKCASE COVER ASSEMBLY	1
11	UP 04335	GASKET-Crankcase Cover (Also included w/short block)	1
12	UP 04295	SCREW-Sems (10-24 X 1/2")	4
13	• UP 04099	MUFFLER GUARD	3
14	UP 03897	SCREW-Plastite (10-14 X 1/2")	2

Torque Specs			
Item No.	In/Lbs	Nm	Required Loctite
9	55-65	6.2-7.3	Red 262
12	35-45	4.0-5.1	Red 262
14	5-20	.6-2.3	

Warranty Flat Rate		
Job	Description	Time/Hr.
FB10	Partial Rebuild	1.0
FB20	Short Block	1.0
FD25	Crankcase Cover	.3

CARBURETOR - FUEL TANK

Non-Clutch

EasyTrim™ (UT20780)
 d825cde (UT20773)
 d825sd (UT20763, UT20774, UT20784)
 ST2517CR (UT20817)
 ST2537S (UT20818)

Clutch

d825sb (UT15165, UT15170)
 K400 (UT15180, UT15181)
 VersaTool™ (UT15164, UT15169)
 BC2500R (UT15200)

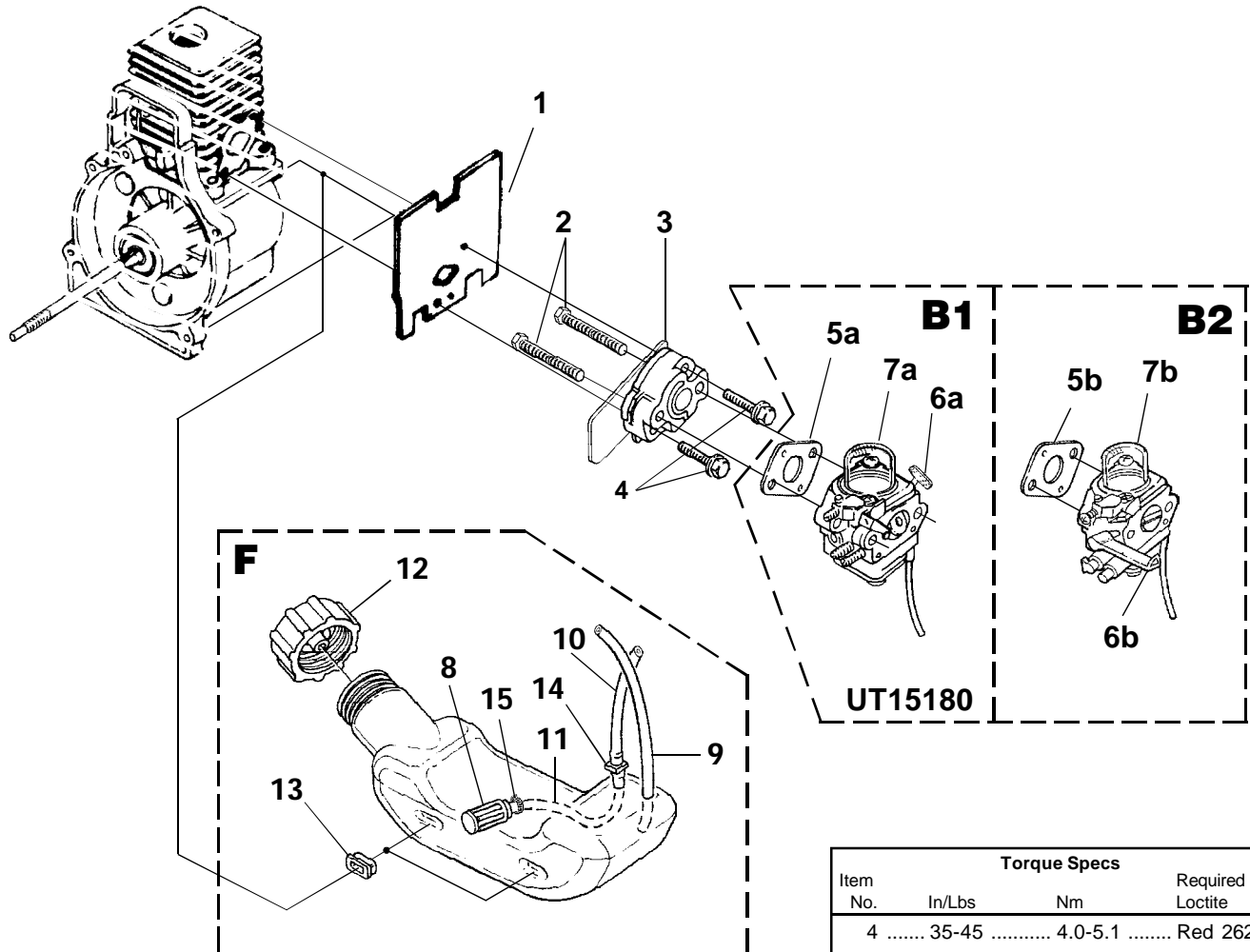

Torque Specs			
Item No.	In/Lbs	Nm	Required Loctite
4	35-45	4.0-5.1	Red 262

Warranty Flat Rate		
Job	Description	Time/Hr.
FF17	Manifold	.3
FF10	Carburetor Rep.	.3
FF16	Fuel Tank	.3
FF12	Fuel/Return Line	.3

No.	Part No.	Description	Qty.
1	UP 04308	GASKET-Heat Dam	1
2	UP 04131	SCREW-Machine (10-24 X 2 1/4")	2
3	UP 04348	HEAT DAM	1
4	UP 04140	SCREW-Sems (10-24 X 1")	2
B1	•UP 00654	CARBURETOR KIT (UT15180)	1
5a	UP 03916	GASKET-Carburetor	1
6a	UP 04278	Lever-Choke (Zama)	1
7a	UP 04803	BULB-Primer	1
B2	•UP 04742	CARBURETOR KIT (Non-Clutch)	1
	UP 05085	CARBURETOR KIT (Clutch)	1
5b	UP 03916	GASKET-Carburetor	1
6b	UP 04740	Lever-Choke	1
7b	UP 04803	BULB-Primer	1

No.	Part No.	Description	Qty.
F	•UP 00020	FUEL TANK ASSY.	1
8	UP 03871	FILTER-Fuel	1
9	UP 04293	TUBING-Rubber	1
10	01439 10	TUBING-Rubber	1
11	UP 04715	TUBING-Rubber	1
12	UP 00106	FUEL CAP	1
13	UP 03501	BUMPER-Rubber	3
14	UP 03831	FITTING-Inline	1
15	UP 03913	CLAMP	1

3/8/2001

Clutch
K400 (UT15180)

MUFFLER - AIR CLEANER

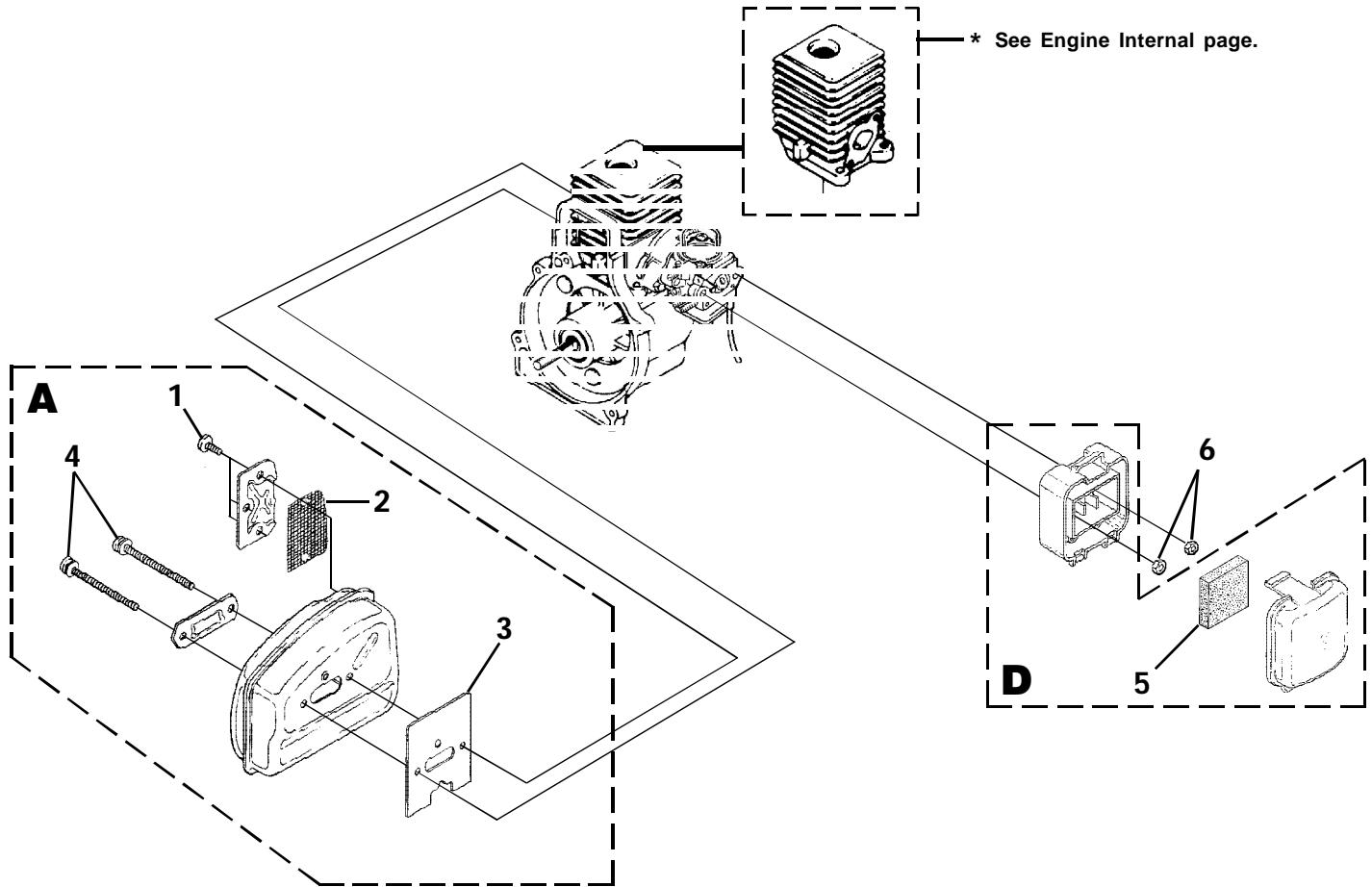

No.	Part No.	Description	Qty.
A	UP 04634	MUFFLER ASSY.	1
1	UP 04258	SCREW, Taptite- (8-32 X 3/8")	3
2	UP 04629	SCREEN-Spark	1
3	UP 04710	GASKET-Muffler	1
4	UP 04258	SCREW, Truss Hd. - (10-24 X 2.188)	2
D	UP 00022	AIR FILTER KIT (Clutch)	1
5	D 98760 B	FILTER-AIR	1
6	UP 03885	NUT-Hex (10-24)	2

Item No.	Torque Specs		Required Loctite
	In/Lbs	Nm	
1	25-35	2.8-4.0	
4	50-60	5.6-6.8	
6	30-40	3.4-4.5	

Warranty Flat Rate		
Job	Description	Time/Hr.
FB18	Muffler-Replace	.3
FF42	Air Filter Assy.	.2

MUFFLER - AIR CLEANER

Non-Clutch

- EasyTrim™ (UT20780)
- d825cde (UT20773)
- d825sd (UT20763, UT20774, UT20784)
- ST2517CR (UT20817)
- ST2537S (UT20818)

Clutch

- d825sb (UT15165, UT15170)
- K400 (UT15181)
- VersaTool™ (UT15164, UT15169)
- BC2500R (UT15200)

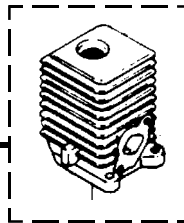

* See Engine Internal

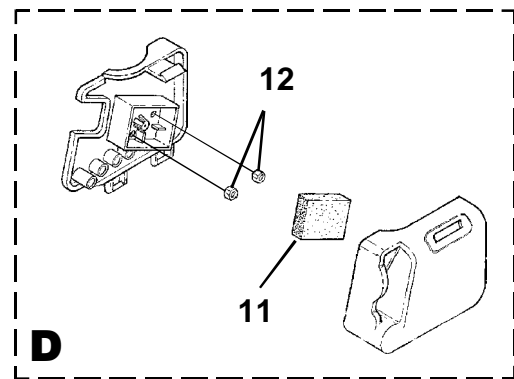
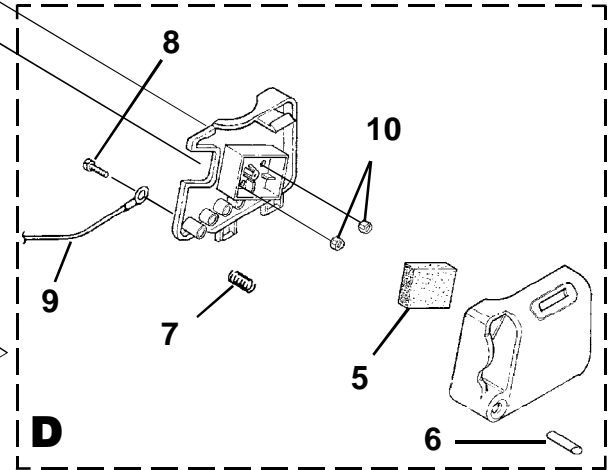
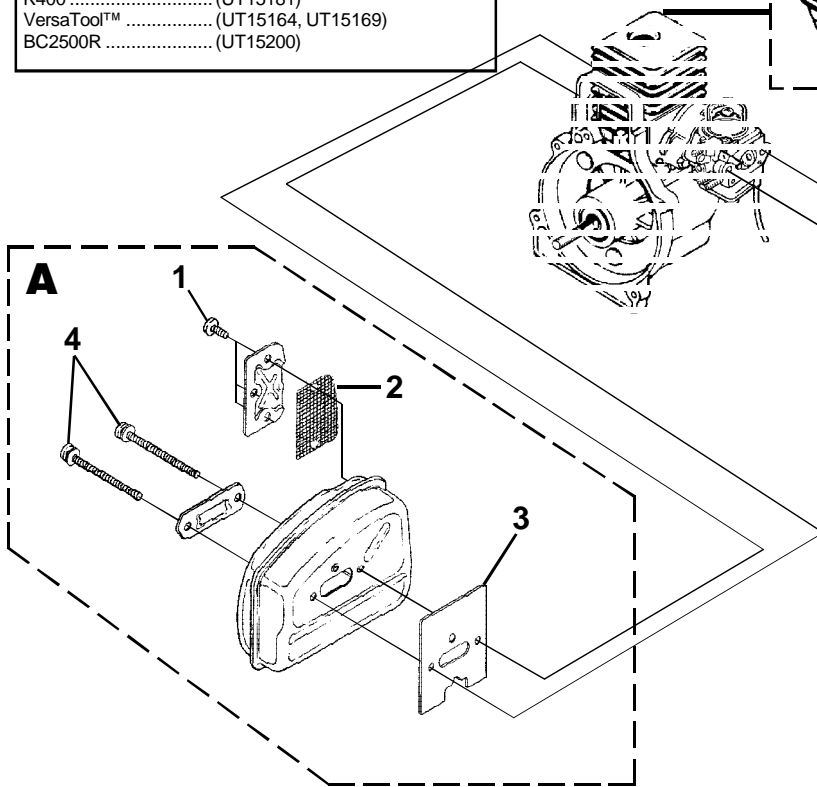

No.	Part No.	Description	Qty.
A	• UP 04634	MUFFLER ASSY.	1
1	UP 04258	SCREW, Taprite- (8-32 X 3/8")	3
2	UP 04629	SCREEN-Spark	1
3	UP 04710	GASKET-Muffler	1
4	UP 04258	SCREW, Truss Hd. - (10-24 X 2.188)	2
D	• UP 04741	AIR FILTER KIT (Non-Clutch)	1
5	D 98760 B	FILTER-Air	1
6	UP 04687	BUTTON-Switch	1
7	UP 04716	SPRING-Compression	1
8	UP 04082	SCREW-Thread Form (6-19 x 1/2")	1
9	UP 04690	LEAD-Electrical	1
10	UP 03885	NUT-Hex (10-24)	2
D	• UP 05084	AIR FILTER KIT (Clutch)	1
11	D 98760 B	FILTER-Air	1
12	UP 03885	NUT-Hex (10-24)	2

Torque Specs			
Item No.	In/Lbs	Nm	Required Loctite
1	25-35	2.8-4.0	
4	50-60	5.6-6.8	
8	5-10	.6-1.1	
10	30-40	3.4-4.5	
12	30-40	3.4-4.5	

Warranty Flat Rate		
Job	Description	Time/Hr.
FB18	Muffler-Replace	.3
FF42	Air Filter Assy.	.2

3/8/2001

SHAFT - SPOOL & STRING - GRASS DEFLECTOR

EasyTrim™ (UT20780)

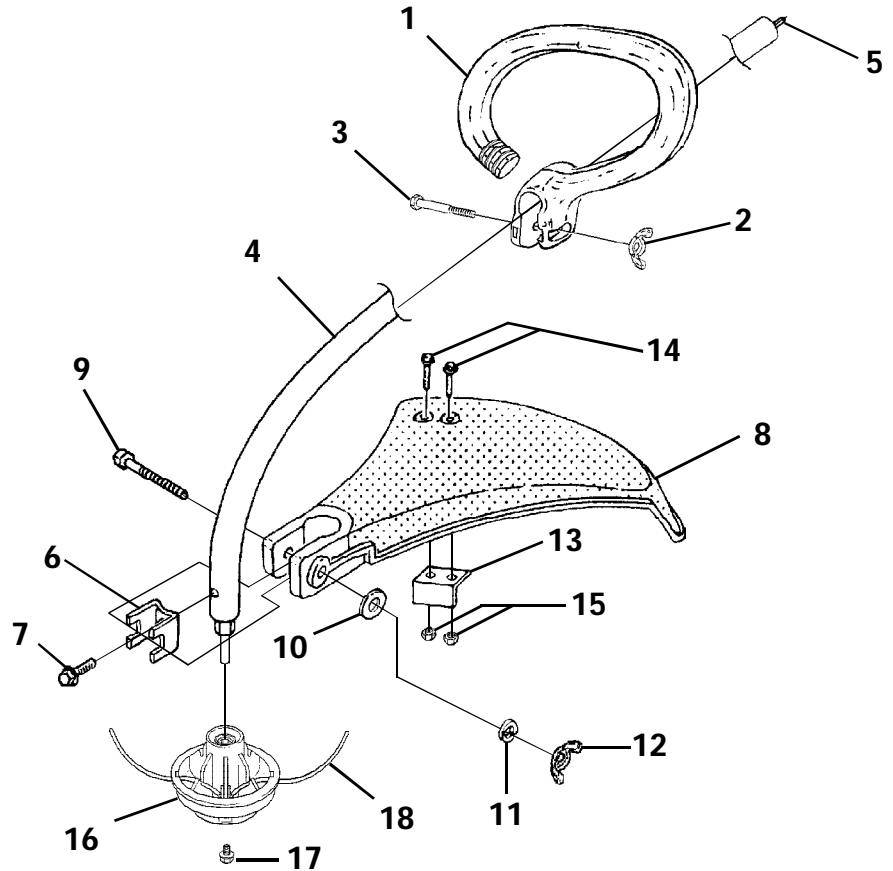

No.	Part No.	Description	Qty.
1	•UP 06959	HANDLE ASSY.-Front	1
2	UP 04262	NUT-Wing, Washer Faced (1/4-20)	1
3	UP 06523	SCREW-Cap Hex Hd.	1
4	•UP 00710	DRIVESHAFT HOUSING ASSY.	1
5	UP 03031	SHAFT-Flexible	1
6	UP 04137	CLAMP	1
7	UP 04256	SCREW-Sems Hex Hd. (#10-24 X 3/8")	1
8	•UP 06710	DEFLECTOR & BLADE KIT (55 Deg.)	1
9	UP 06523	SCREW-Cap Hex Hd. (10-24 X 2")	1
10	UP 03415	WASHER-Flat (1/4")	1
11	UP 03409	WASHER-Lock (1/4")	1
12	UP 04262	NUT-Wing, Washer Faced (1/4-20)	1
13	•UP 04119	BLADE-Cut-Off	1
14	UP 04159	SCREW-Mech. Hex Hd. (10-24 X 7/8")	2
15	UP 03885	NUT-Hex (10-24)	2
16	•DA 09364	STRINGHEAD-Pro-Cut w/line	1
17	UP 04102	SCREW (5/16-18 x 5/8")	1
18	D 09365	LINE-Replacement	1

Item No.	Torque Specs		Required Loctite
	In/Lbs	Nm	
2	5-25	.6-2.8	
7	15-25	1.7-2.8	
12	5-25	.6-2.8	
15	30-40	3.4-4.5	
17	40-60	4.5-6.8	

Warranty Flat Rate		
Job	Description	Time/Hr.
FM10	Stringhead Assy.	.2
FN12	Driveshaft	.3
FN13	Driveshaft Hsg	.3
FN16	Deflector-Grass	.2
FD20	Front Handle	.2

SHAFT - SPOOL & STRING - GRASS DEFLECTOR

d825cde (UT20773)
ST2517CR (UT20817)

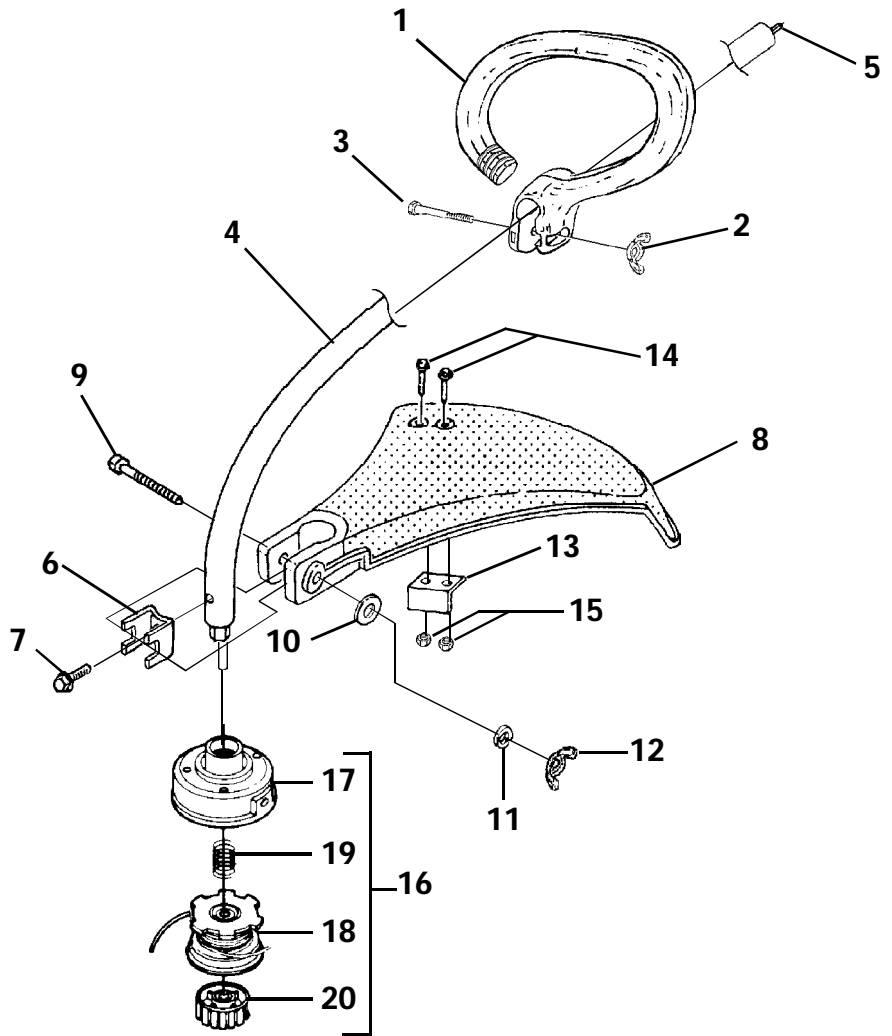

No.	Part No.	Description	Qty.
1	•UP 06959	HANDLE ASSY.-Front	1
2	UP 04262	NUT-Wing, Washer Faced (1/4-20)	1
3	UP 06523	SCREW-Cap Hex Hd.	1
4	•UP 00710	DRIVESHAFT HOUSING ASSY.	1
5	UP 03031	SHAFT-Flexible	1
6	UP 04137	CLAMP	1
7	UP 04256	SCREW-Sems Hex Hd. (#10-24 X 3/8")	1
8	•UP 06710	DEFLECTOR & BLADE KIT (55 Deg.)	1
9	UP 06523	SCREW-Cap Hex Hd. (10-24 X 2")	1
10	UP 03415	WASHER-Flat (1/4")	1
11	UP 03409	WASHER-Lock (1/4")	1
12	UP 04262	NUT-Wing, Washer Faced (1/4-20)	1
13	•UP 04119	BLADE-Cut-Off	1
14	UP 04159	SCREW-Mech. Hex Hd. (10-24 X 7/8")	2
15	UP 03885	NUT-Hex (10-24)	2
16	•DA 03001 A	STRINGHEAD-Complete (.080") (UT20817)	1
	•DA 04591 A	STRINGHEAD-Complete (.095") (UT20773)	1
17	A 98231 A	HOUSING & EYELET (Dual Line)	1
18	•UP 00145	SPOOL & STRING (.080")	1
	•UP 00147	SPOOL & STRING (.095")	1
19	06713	SPRING-Compression	1
20	DA 98866 A	RETAINER-Spool (R.H. Thread, Black)	1

Torque Specs			
Item No.	In/Lbs	Nm	Required Loctite
2	5-25	6-2.8	
7	15-25	1.7-2.8	
12	5-25	6-2.8	
15	30-40	3.4-4.5	

Warranty Flat Rate		
Job	Description	Time/Hr.
FM10	Stringhead Assy.	.2
FN12	Driveshaft	.3
FN13	Driveshaft Hsg.	.3
FN16	Deflector-Grass	.2
FD20	Front Handle	.2

3/8/2001

SHAFT - SPOOL & STRING - GRASS DEFLECTOR

d825sd (UT20763, UT20774, UT20784)

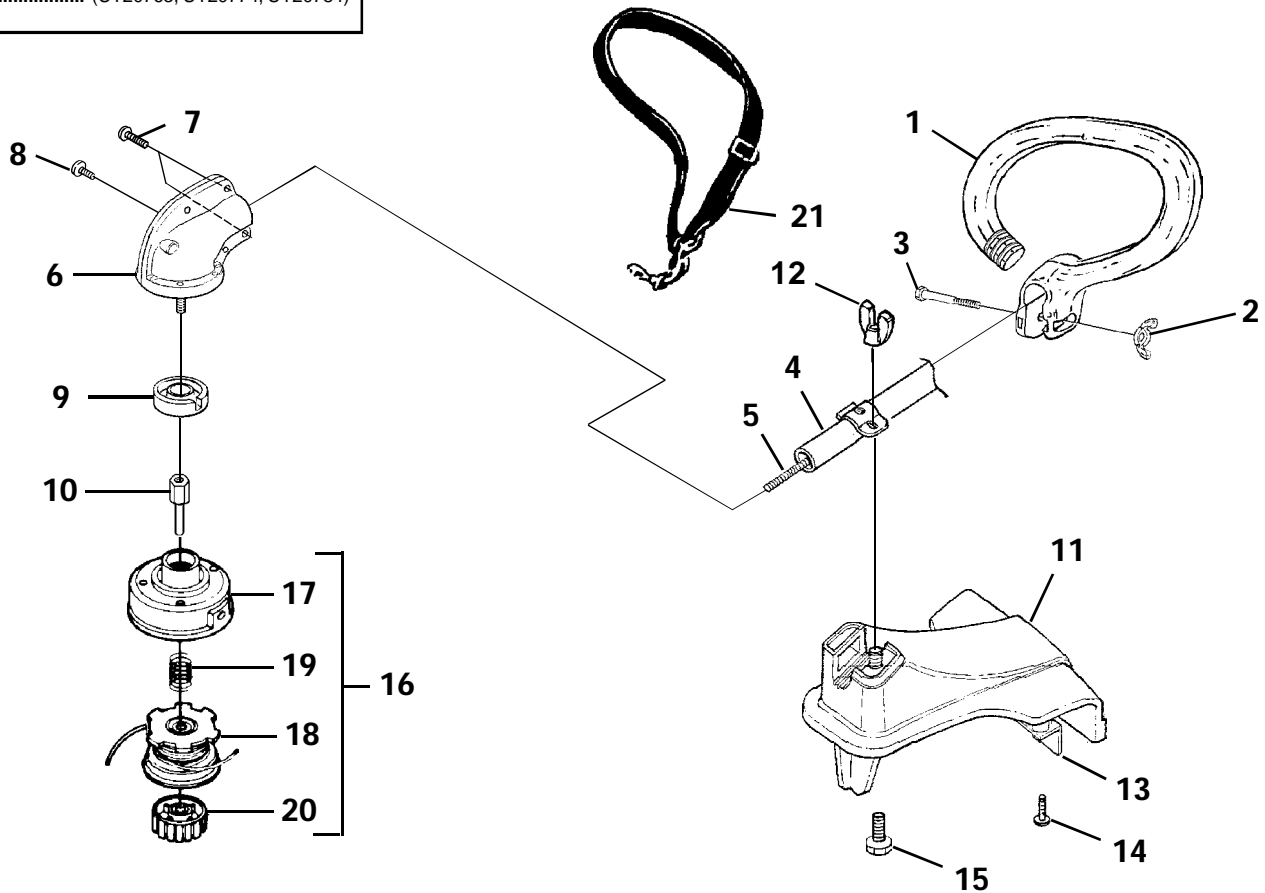

No.	Part No.	Description	Qty.
1	•UP 06959	HANDLE-Anti-Vibe	1
2	UP 04262	NUT-Wing, Washer Faced (1/4-20)	1
3	UP 06523	SCREW-Cap Hex Hd. (1/4-20 x 2")	1
4	•UP 04891	DRIVESHAFT HOUSING ASSY.	1
5	UP 04717	SHAFT-Flexible	1
6	•UP 06970	GEARHEAD	1
7	UP 04157	Screw, Taptite Hex Hd. (10-24 x 1/2")	5
8	UP 04155	Screw-Hex Hd. (10-24 x 5/8")	2
9	UP 04126	WASHER-Flanged	1
10	UP 04128	ADAPTER-Shaft	1
11	•UP 04888	GRASS DEFLECTOR KIT	1
12	UP 04893	WING NUT	1
13	•UP 04890	BLADE-Cut-off	1
14	UP 03898	SCREW-Mach.Hex Hd. (10-24 X 3/8")	2
15	UP 04892	SCREW-Square Head	1
16	•DA 03001 A	STRINGHEAD-Complete (.080") (UT20818)	1
	•DA 04591 A	STRINGHEAD-Complete (.095")	1
17	UP 06567	HOUSING & EYELET (Dual Line)	1
18	•UP 00145	SPOOL & STRING (.080")	1
	•UP 00147	SPOOL & STRING (.095")	1
19	UP 06526	SPRING-Compression	1
20	DA 98866 A	RETAINER-Spool (R.H. Thread, Black)	1
21	UP 00108	HARNESS	1

Torque Specs			
Item No.	In/Lbs	Nm	Required Loctite
2	Hand Tight	
7 15-20 1.7-2.3	
8 40-50 4.5-5.6	
10 100-120 11.3-13.6	
12	Hand Tight	
14 30-40 3.4-4.5	

Warranty Flat Rate		
Job	Description	Time/Hr.
FM10	... Stringhead Assy.2
FN12	... Driveshaft3
FN13	... Driveshaft Hsg.3
FN15	... Gearhead3
FD20	... Front Handle2

SHAFT - SPOOL & STRING - GRASS DEFLECTOR

d825sb (UT15165, UT15170)
 K400 (UT15180, UT15181)
 VersaTool™ (UT15164, UT15169)
 BC2500R (UT15200)

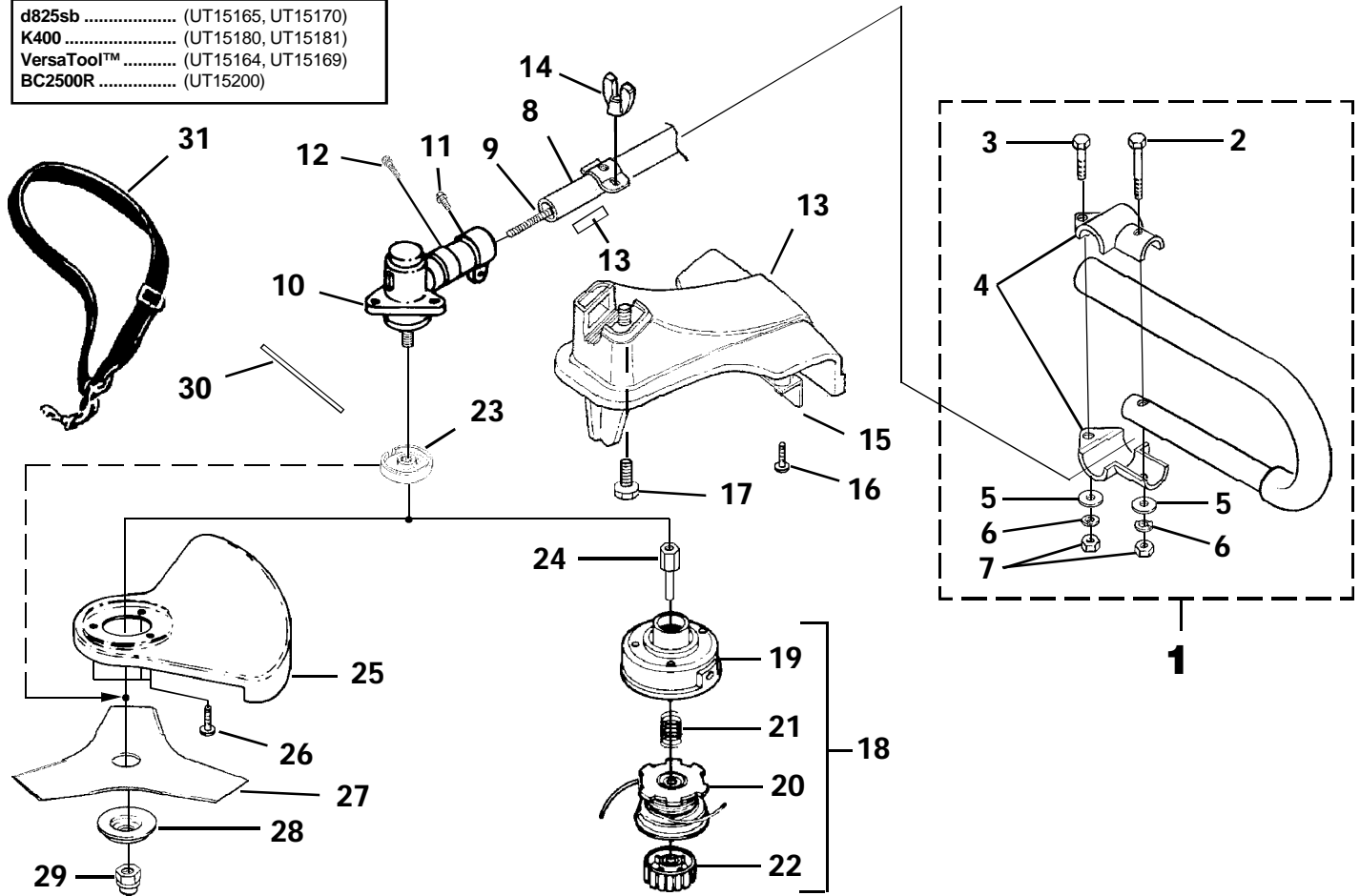

No.	Part No.	Description	Qty.
1	• UP 06534	HANDLE("J")	1
2	UP 04154	SCREW-Hex Hd. (1/4-20 X 1 1/2")	1
3	UP 04158	SCREW-Hex Hd. (1/4-20 X 1")	1
4	UP 04105	CLAMP-Handle Bar	2
5	UP 04251	WASHER-Flat (1/4")	2
6	UP 03409	WASHER-Lock (1/4")	2
7	UP 03399	NUT-Hex (1/4-20)	2
8	• UP 05071	DRIVESHAFT HOUSING	1
9	UP 05072	FLEXSHAFT	1
10	• UP 04124	GEAR HEAD	1
11	UP 05572	Screw, Cap Hd. (1/4-20 X 7/8")	5
12	UP 04254	Screw-Hex Hd. (10-24 x 1/2")	2
13	• UP 05086	GRASS DEFLECTOR KIT	1
14	UP 04893	WING NUT	1
15	• UP 04890	BLADE-Cut-Off	1
16	UP 03898	SCREW, Thread Form. (10-24 X 3/4")	2
17	UP 04892	SCREW-Square Head	1

No.	Part No.	Description	Qty.
18	• DA 04592 A	STRINGHEAD-Complete (.080") (UT15180, UT15181, UT15164, UT15169)	1
	• DA 03174 A	STRINGHEAD-Complete (.095") (UT15165, UT15170, UT15200)	1
19	UP 06567	HOUSING & EYELET (Dual Line)	1
20	• UP 00145	SPOOL & STRING (.080")	1
	• UP 00147	SPOOL & STRING (.095")	1
21	UP 06526	SPRING-Compression	1
22	UP 00104	RETAINER-Spool (L.H. Thread, Red)	1
23	UP 04126	WASHER-Flanged	1
24	UP 04269	ADAPTER-Shaft	1
25	• UP 05070	BLADE GUARD	1
26	UP 04254	SCREW	3
27	D 98717 C	BLADE-Tri-Arc™	1
28	UP 04129	WASHER-Cupped (Lower)	1
29	UP 04127	NUT-Hex (L.H.)	1
30	UP 04100	TOOL-Holding Pin	1
31	UP 00108	HARNESS	1

Warranty Flat Rate		
Job	Description	Time/Hr.
FM10	... Stringhead Assy.2
FN13	... Driveshaft Housing4
FN15	... Gearhead3
FN16	... Deflector3

Torque Specs			
Item No.	In/Lbs	Nm	Required Loctite
7	90-100	10.2-11.3	
11	15-20	1.7-2.3	
12	40-50	4.5-5.6	
16	30-50	3.4-5.6	
24	100-120	11.3-13.6	
26	15-20	1.7-2.3	
29	100-120	11.3-13.6	

ACCESSORIES

GREASE, MULTI-PURPOSE	18453	STRINGHEAD-Complete - E-Z Line™	DA 04591 A (.095 Line) (Right Hand Thread) (Black Retainer)
MODULE AIR GAP SHIM	PS 24306	STRINGHEAD-Complete - E-Z Line™	DA 03174 A (.095 Line) (Left Hand Thread) (Red Retainer)
GRASS ANTI-WRAP KIT	A 04191	REPLACEMENT STRING - E-Z Line™ (3 lb. Box)	03959 04 (.095" Dia.)
STARTER ROPE (250 Ft. Reel)	98052 A	STRINGHEAD-Complete-Pro-Cut™ Fixed Line Head	DA 09364 (.105" Dia.)
TORX BIT (T25)	UP 06544 (For Clutch Drums)	REPLACEMENT DuraLine™ (.105" Dia.)	D 09365 (Cartridges for Pro-Cut™ Fixed Line Head)
TORX BIT (T27)	UP 07160	SAFETY GOGGLES	A 06933
IGNITION TEST SPARK PLUG	JA 31316 4	DUST MASK	UP 03036
RUBBER TUBING (10 Ft.)	UP 05860	COMFORT STRAP	UP 00108
STRINGHEAD-Complete - E-Z Line™	DA 03001 A (.080 Line) (Right Hand Thread) (Black Retainer)		
STRINGHEAD-Complete - E-Z Line™	DA 04592 A (.080 Line) (Left Hand Thread) (Red Retainer)		
REPLACEMENT STRING - E-Z Line™ (3 lb. Box)	98011 06 (.080" Dia.)		

FOR USE ON BRUSHCUTTER UNITS ONLY

TRI-ARC™ BLADE D 98717 C

For product information, technical help, dealer locations or parts ordering information visit our website at:
www.homelite.com.

John Deere Consumer Products Limited
Produits Consommateurs John Deere Limitée

1850-55e/th Avenue
Lachine, Québec, Canada H8T 3J5
tel: 1-514-636-5900 / fax: 1-514-636-9966

John Deere Consumer Products International B.V.

Haverstraat 24
2153 GB Nieuw Vennep
The Netherlands
tel: +31-252-687342 / fax: +31-252-687993

John Deere Limited

A.C.N. 008 671 725
166-170 Magnesium Drive
Crestmead, Queensland 4132
Australia
tel: 61-7-3802-3222 / fax: 61-7-3803-6555

JOHN DEERE
WORLDWIDE COMMERCIAL & CONSUMER EQUIPMENT DIVISION

4401 Bland Road, Suite 200
Raleigh, NC 27609

Phone 1-800-537-8233