

Homelite®

PARTS LIST



MODEL

33cc – 16 in. UT10947D

STARTER – IGNITION

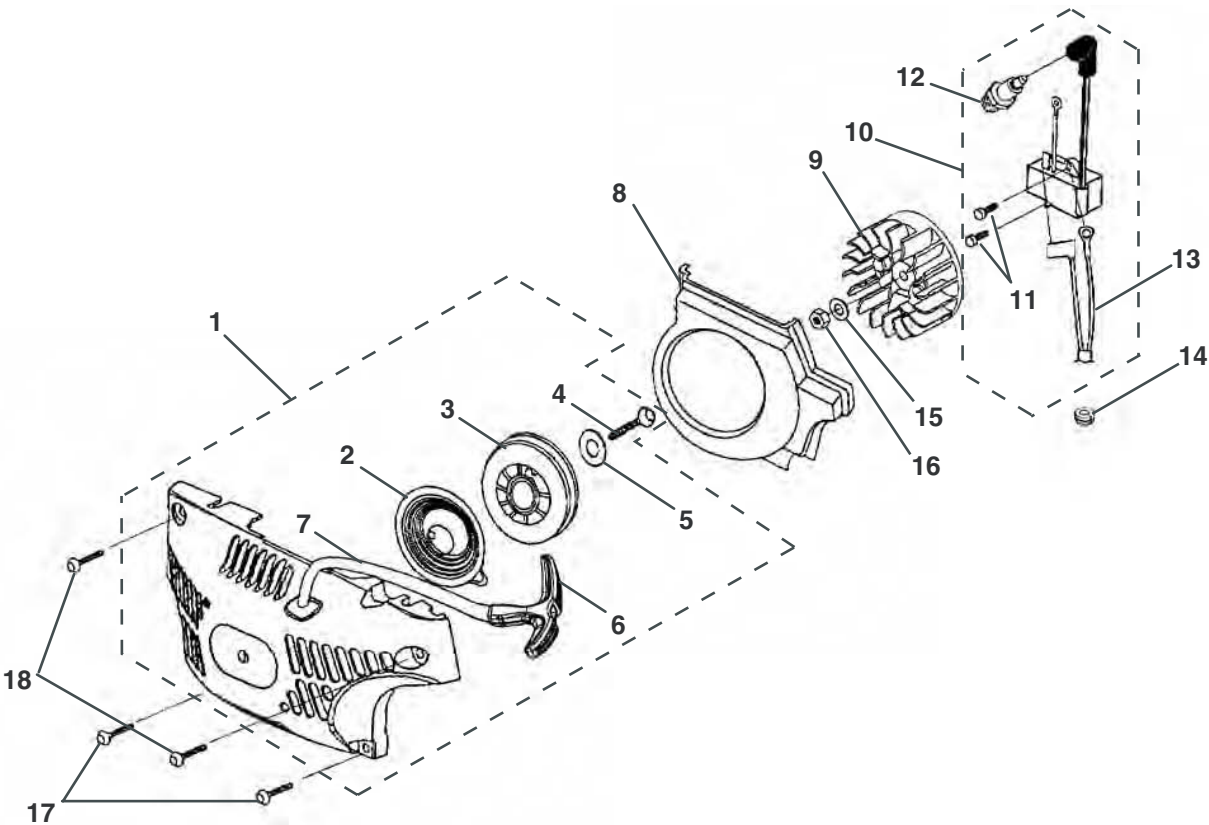

NO.	PART NO.	DESCRIPTION	QTY.
1	984881001	STARTER HOUSING ASSEMBLY	1
2	A97908	SPRING & CONTAINER	1
3	PS03117	STARTER PULLEY	1
4	82621	SCREW, THREAD FORM, PLASTITE (10-14 X 5/8 in.)	1
5	94062	WASHER RETAINING	1
6	PS06114	GRIP STARTER	1
7	9789901	STARTER ROPE (46 in.)	1
8	06876	BAFFLE, FAN HOUSING	1
9	UP05850A	ROTOR & STARTER PAWL	1
10	984882001	IGNITION KIT (33 cc)	1
11	82575	SCREW, THREAD FORM (8-32 x 5/8 in.)	2
12	PS02227	SPARK PLUG	1
13	A07602A	IGNITION SWITCH HARNESS	1
14	07587	GROMMET, WIRE HARNESS (SPLIT)	1
15	PS84065	WASHER, FLAT	1
16	81229A	JAM NUT	1
17	82620	SCREW, TRUSS HD. PLASTITE (10-14 x 7/8 in.)	2
18	82621	SCREW, TRUSS HD. PLASTITE (10-14 x 5/8 in.)	2

ITEM NO.	TORQUE SPECS. in./lbs.	TORQUE SPECS. nm	REQUIRED LOCTITE
4	30-40	3.4-4.5	
11	30-40	3.4-4.5	242 blue
12	120-180	13.6-20.3	
16	100-150	11.3-20.3	
17	30-40	3.4-4.5	
18	30-40	3.4-4.5	

ENGINE INTERNAL - OIL PUMP

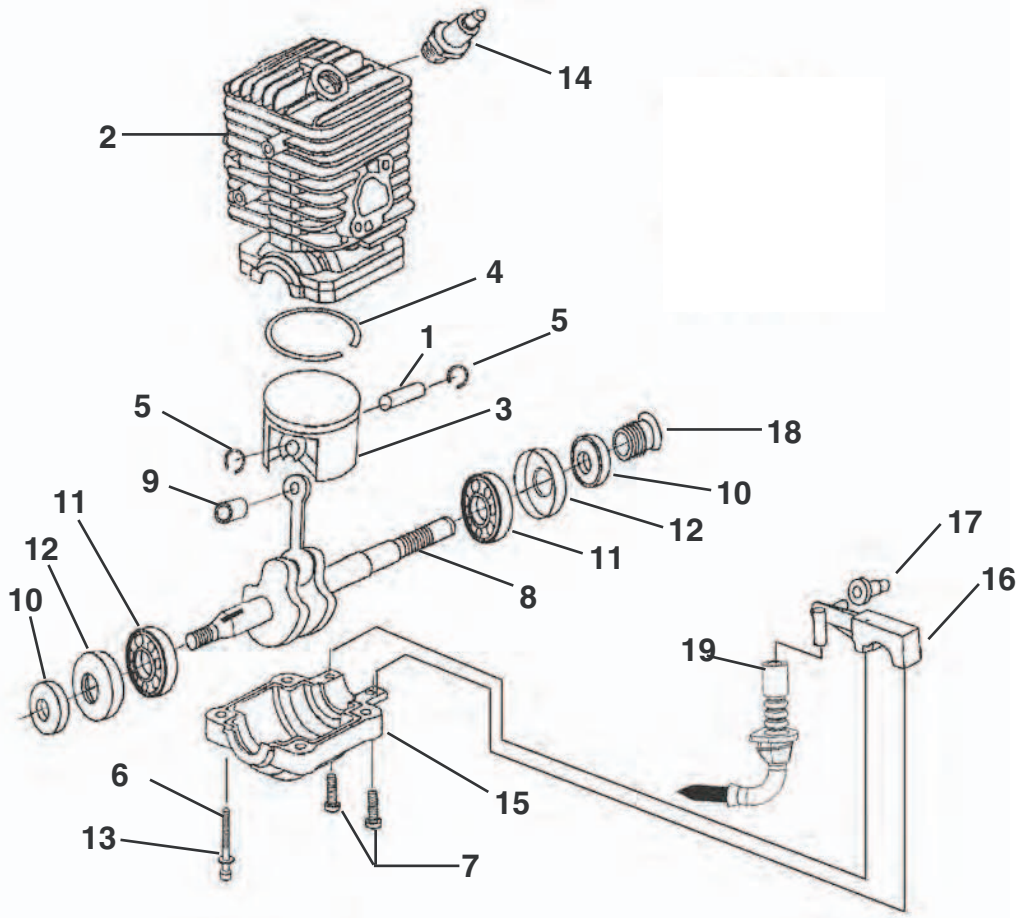

NO.	PART NO.	DESCRIPTION	QTY.
1	04932	PISTON PIN	1
2	068531	CYLINDER MACH/PLATED	1
3	A04935	33CC PISTON (MACH)	1
4	04933	PISTON RING	1
5	64813	RETAINING RING	2
6	82527	SCREW TORX PLUS CAP-SOCKET HD	4
7	PS04989	SCREW, (8/32 X 5/8 in. PAN HD TORX)	2
8	PA00979	33 CC CRANKSHAFT ASSEMBLY	1
9	PS04921	NEEDLE BEARING	1
10	04920	SHAFT SEAL	2
11	08838	BALL BEARING	2
12	04919	BEARING CASE	2
13	84008	FLAT WASHER	4
14	PS02227	SPARK PLUG	1
15	04909	CRANKCASE (33CC) CS	1
16	PA01396	OIL PUMP ASSEMBLY	1
17	06841	GROMMET, OIL OUTLET	1
18	06847	LEFT HAND WORM	1
19	PA01037	OIL INTAKE TUBE W/FILTER	1

ITEM NO.	TORQUE SPECS.		REQUIRED LOCTITE
	in./lbs.	nm	
6	65-75	7.3-8.5	262 RED
7	15-20	1.7-2.3	
14	120-180	13.6-20.3	

CARBURETOR – MUFFLER – AIR FILTER

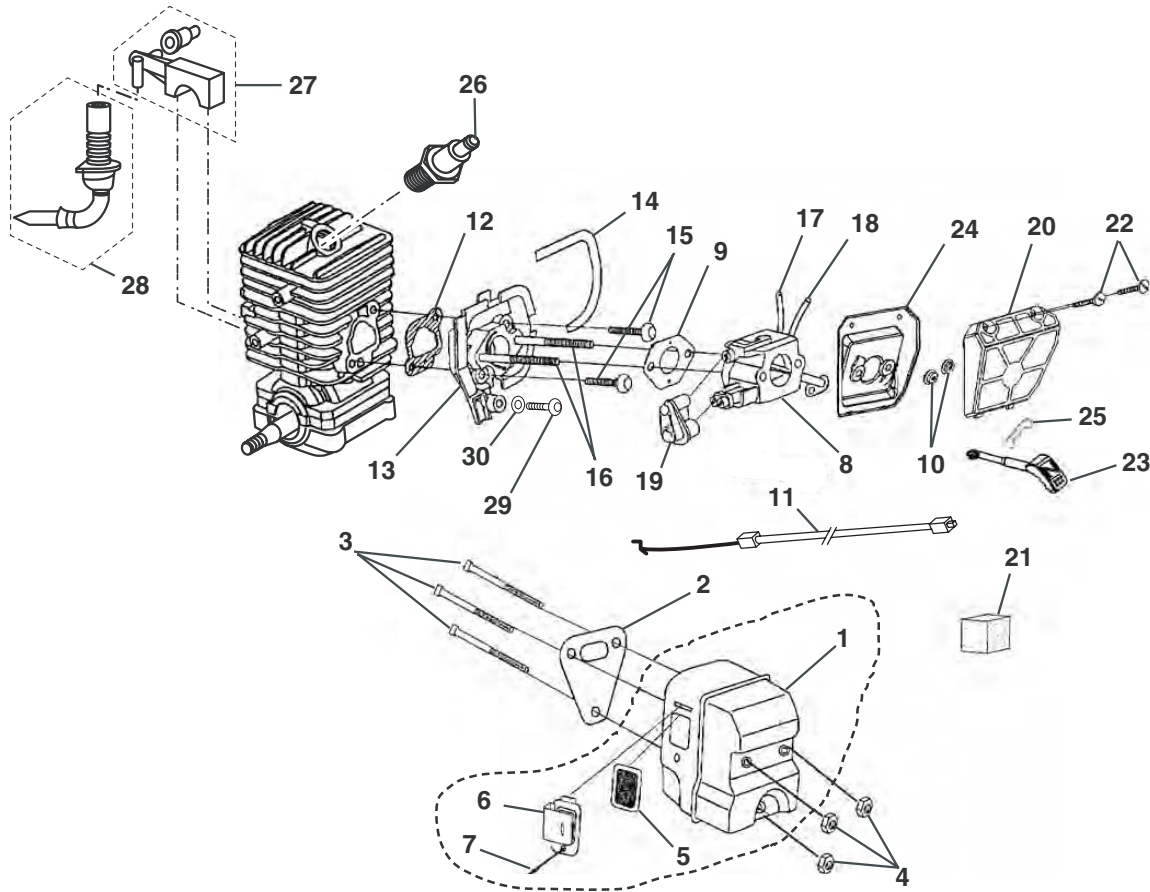

NO.	PART NO.	DESCRIPTION	QTY.	NO.	PART NO.	DESCRIPTION	QTY.
1	A07402	MUFFLER	1	22	82617	SCREW, SLOTTED PAN HD. (8-16 x 5/8 in.)	2
2	06839	MUFFLER GASKET	1	23	PS06280	ROD, CHOKE	1
3	PS04525	SCREW-SQUARE HD.	3	24	04937	AIR FILTER PLATE	1
4	81206	NUT-LOCKING HEX (10-32)	3	25	08939	SPRING CLIP (CHOKE ROD)	1
5	07394	SCREEN, SPARK	1	26	PS02227	SPARK PLUG	1
6	07396A	DEFLECTOR, MUFFLER	1	27	PA01396	OIL PUMP ASSY.	1
7	95922	SCREW (8-32 x .312)	1	28	PA01037	OIL INTAKE W/FILTER	1
8	984922001	CARBURETOR	1	29	82541	SCREW THREAD FORMING (10-14 x .5)	1
9	98339	CARBURETOR GASKET	1	30	12789	WASHER, RETAINING	1
10	07589	FLANGE NUT (10-24)	2				
11	A07596B	THROTTLE CABLE	1				
12	06840A	GASKET, HEAT DAM	1				
13	04916	HEAT DAM	1				
14	06873	SEAL, HEAT DAM	1				
15	82539	SCREW, TRUSS HD. (10-24 x 7/8 in.)	2				
16	06852	SCREW, CARBURETOR	2				
17	0745434	FUEL LINE (TANK TO CARB. 8-1/2 in.)	1				
18	0745434	FUEL LINE (CARB. TO PURGE BULB 4 in.)	1				
19	04907	CARBURETOR GROMMET	1				
20	04938	AIR FILTER COVER	1				
21	PS05070	PRE FILTER (IN ENGINE HOUSING)	1				

ITEM NO.	TORQUE SPECS.		REQUIRED LOCTITE
	in./lbs.	nm	
4	50-60	5.6-6.7	
10	30-40	3.4-4.5	
15	45-55	5.0-6.2	
22	15-20	1.7-2.3	

*** NOTE:**

Part No. 0745434 (Items #17 and 18) come standard 8 1/2 inches in Length. Item #18 should be cut to 4 in.

CARBURETOR – AIR FILTER

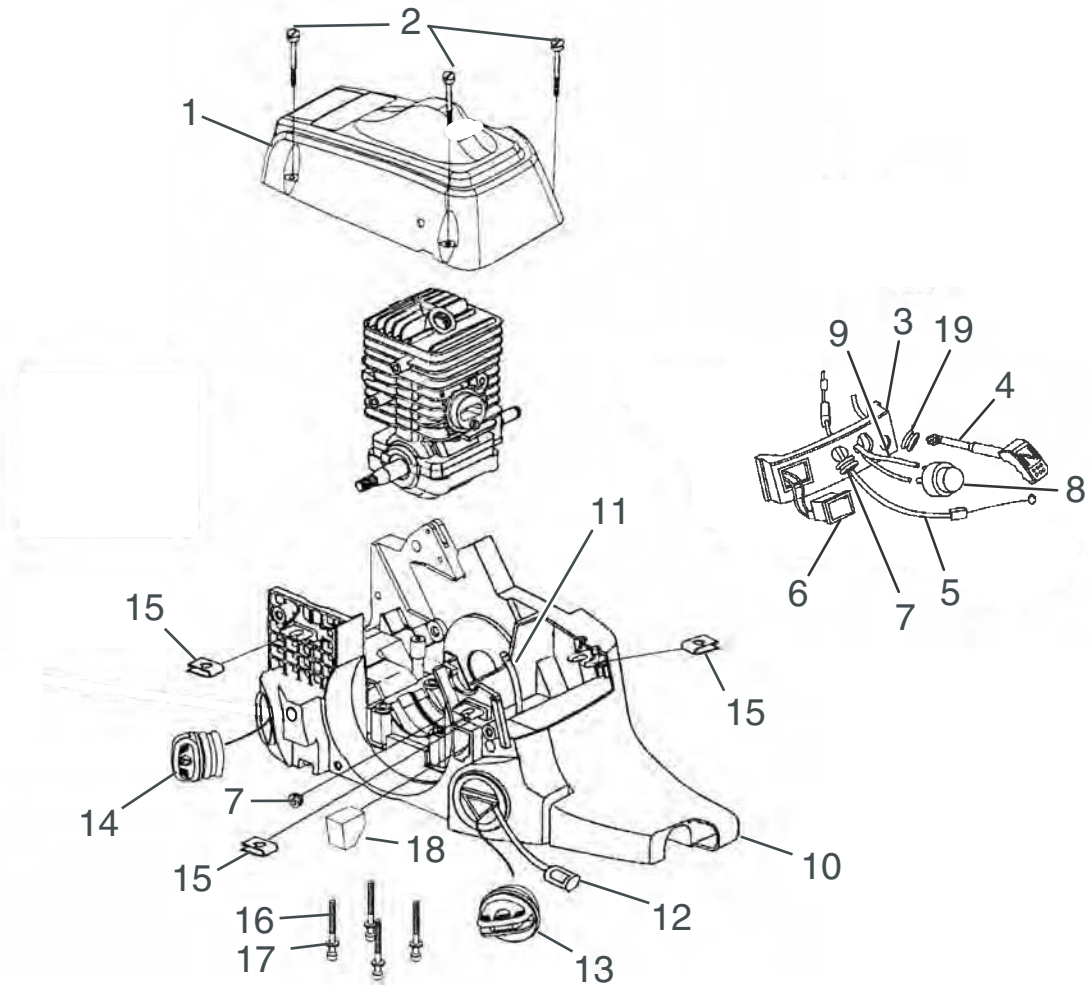

NO.	PART NO.	DESCRIPTION	QTY.
1	06875	CYLINDER COVER	1
2	07597	SCREW-SLOTTED PAN HEAD	3
3	PS03503	CONTROL PANEL	1
4	PS06280	CHOKE ROD	1
5	A07596B	THROTTLE CABLE	1
6	07385	ROCKER SWITCH	1
7	07587	SPLIT GROMMET	2
8	01183	PRIMER BULB	1
9	0745434	* RUBBER TUBING (5-1/2 in.)	1
10	985029001	CHASSIS	1
11	0745434	* RUBBER TUBING (8-1/2 in.)	1
12	PS03380	FUEL FILTER	1
13	PA01645	FUEL CAP, W/RETAINER	1
14	PA01646	OIL CAP, W/RETAINER	1
15	07598	SPEED NUT (U-TYPE)	3

NO.	PART NO.	DESCRIPTION	QTY.
16	82527	SCREW, (10-24 x 2 in.)	4
17	84008	WASHER	4
18	PS05070	PRE FILTER	1
19	64862	GROMMET	1
[PS00340	CHAIN BRAKE DECAL	1
	PS06324	SAFETY DECAL	1
	PS06321	D/C COVER DECAL	1
	PS06322	STARTER HOUSING DECAL	1
	PS06323	KICK BACK DECAL	1
	PS06341	HELP / START DECAL	1

ITEM NO.	TORQUE SPECS. in./lbs.	TORQUE SPECS. Nm	REQUIRED LOCTITE
2	15-25	1.7-2.8	
16	65-75	7.3-8.5	262 RED

*** NOTE:**

Part No. 0745434 (Items #9 and 11) come standard 8 1/2 inches in Length. Item #9 should be cut to 5-1/2 in.

CLUTCH – CHAIN BRAKE – DRIVE CASE COVER

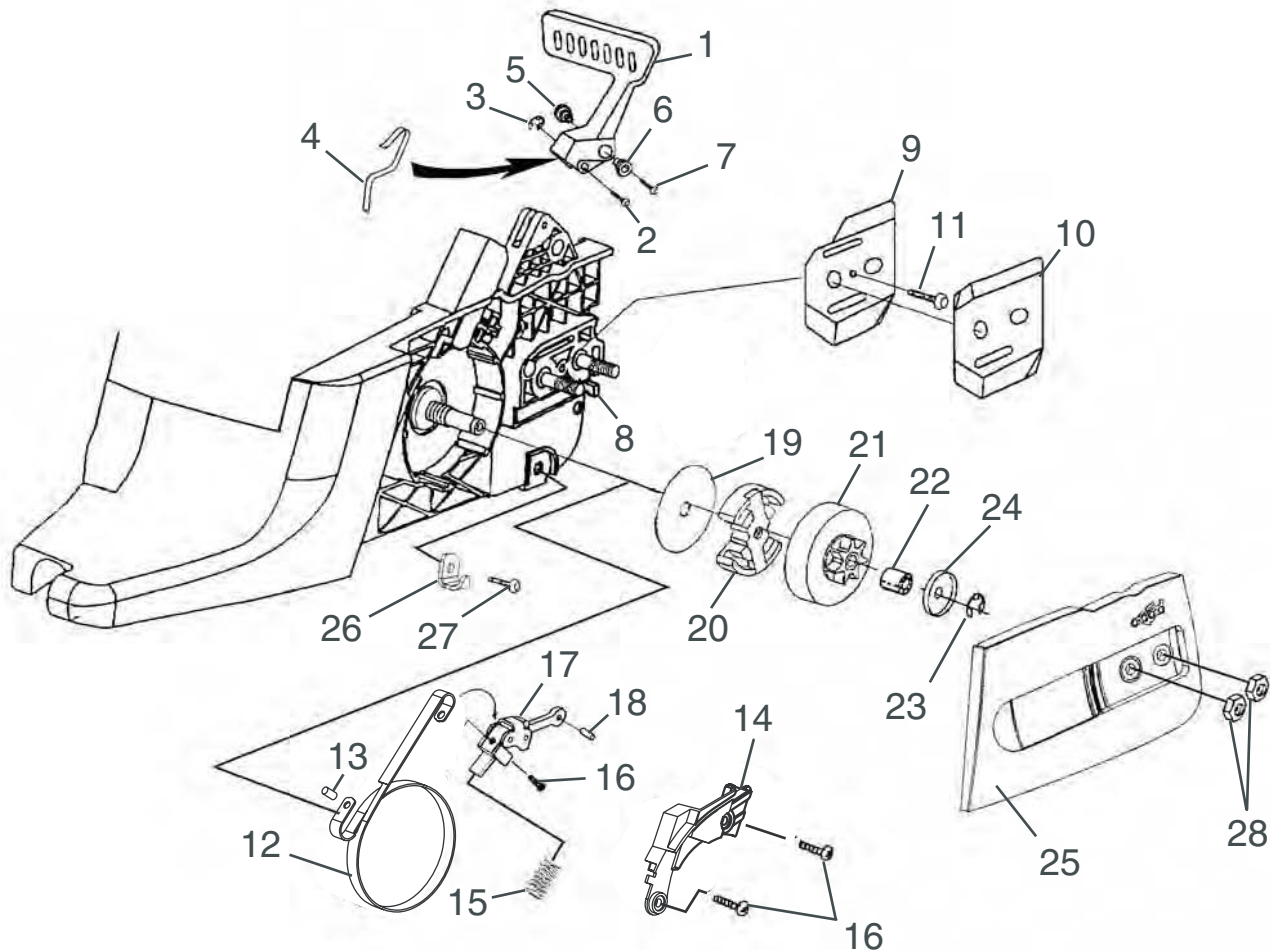

NO.	PART NO.	DESCRIPTION	QTY.
1	07386B	HAND GUARD	1
2	07580	HAND GUARD ACTUATING PIN	1
3	69599	RETAINING RING	1
4	07613	HANDGUARD SPRING	1
5	07393	PIVOT, L.H.	1
6	07392	PIVOT, R.H.	1
7	82624	SCREW (8-32 x 5/8 in.)	1
8	984901001	ADJUSTING PIN	1
9	07404A	GUIDE BAR PLATE	1
10	07405A	GUIDE BAR PLATE	1
11	82513	SCREW (6-19 x 1/2 in.)	1
12	985030001	BRAKE BAND	1
13	06672	ROLL PIN	1
14	985021001	CHAIN BRAKE COVER	1
15	985240001	COMPRESSION SPRING	1
16	82623	SCREW (8-16 x .320)	3
17	984897001	CHAIN BRAKE LINK	1
18	95395A	ROLL PIN	1
19	04940	THRUST WASHER	1
20	984898001	CLUTCH & HARDWARE	1
21	984350001	DRUM SPROCKET (.375 PITCH)	1
22	PS04669	NEEDLE BEARING	1
23	08981	RETAINING RING	1
24	04939A	CUPPED WASHER	1
25	PA01106	DRIVE CASE COVER ASSEMBLY	1
26	PS02928	CHAIN CATCHER	1

NO.	PART NO.	DESCRIPTION	QTY.
27	82541	SCREW (10-24 x 1/2 in.)	1
28	81196	HEX NUT	2

ITEM NO.	TORQUE SPECS. in./lbs.	TORQUE SPECS. nm	REQUIRED LOCTITE
7	25-35	2.8-3.9	242 BLUE
11	8-18	0.9-2.0	
16	20-30	2.3-3.4	
20	130-180	14.7-20.3	
27	30-50	3.4-5.6	
28	HAND TIGHT		

HANDLES

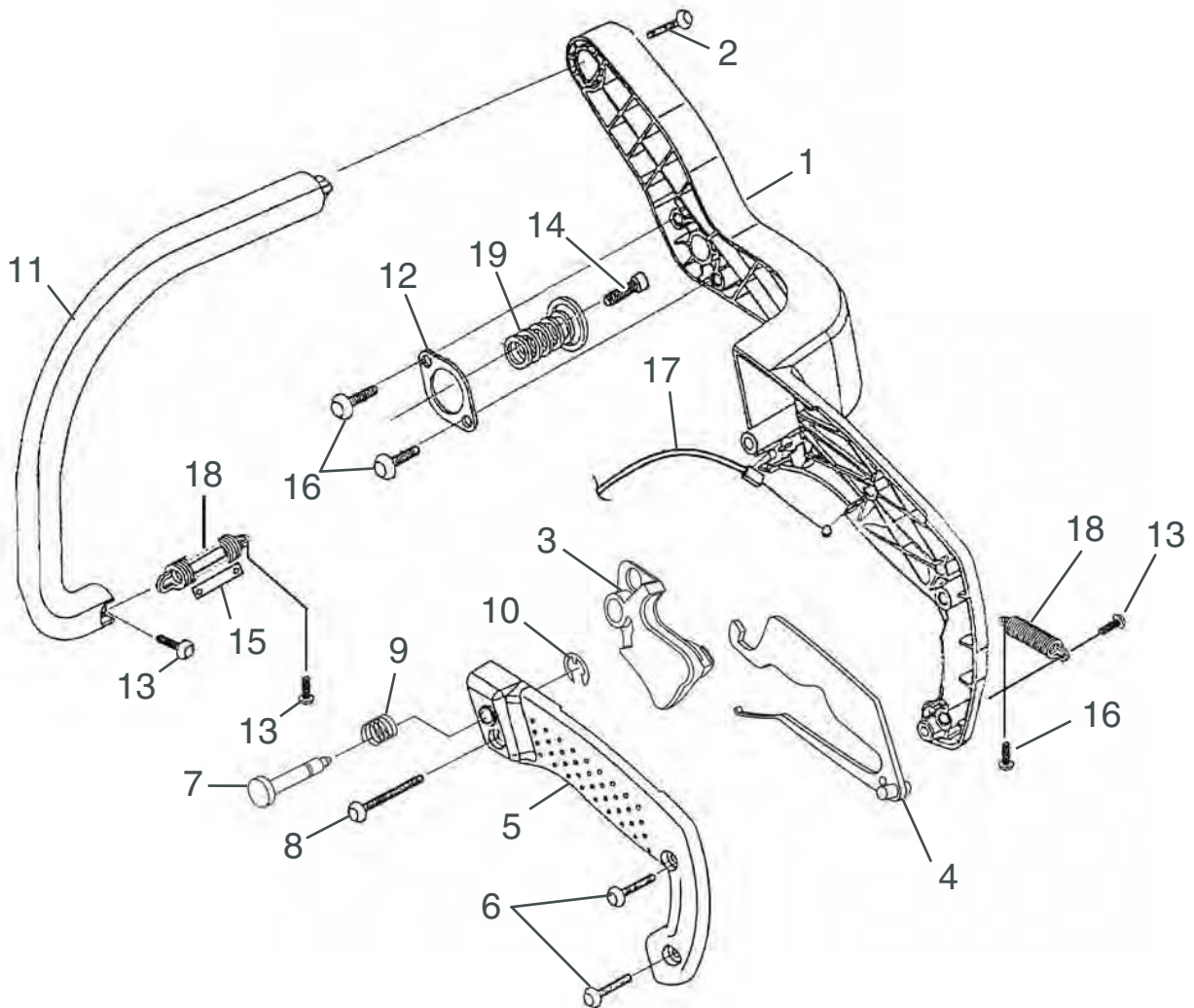

NO.	PART NO.	DESCRIPTION	QTY.
1	06870	REAR HANDLE	1
2	82615	SCREW (12-14 x 1-1/2 in.)	2
3	984354002	THROTTLE TRIGGER	1
4	PS06283	THROTTLE LOCK OUT	1
5	06871	HANDLE COVER	1
6	82563	SCREW (10-14 x 3/4 in.)	2
7	PS06281	THROTTLE PIN LOCK	1
8	82622	SCREW (10-14 x 1- 3/8 in.)	1
9	08898	SPRING	1
10	58409	E-RING	1
11	PS03985	FRONT HANDLE	1
12	07384	ISOLATOR PLATE	1
13	82621	SCREW (10-14 x 5/8 in.)	3
14	82597	SCREW (10-24 x 5/8 in.)	1
15	01812A	LIMITER, ISOLATOR	1
16	82541	SCREW (10-14 x 1/2 in.)	3
17	A07596B	THROTTLE CABLE	1
18	PS05217	EXTENSION SPRING	2
19	PS05199	UPPER ISOLATION SPRING	1
	PS05239	INSTRUCTION SHEET	

ITEM NO.	TORQUE SPECS.		REQUIRED LOCTITE
	in./lbs.	nm	
2.....	40-50	4.5-5.6	
6.....	30-40	3.4-4.5	
8.....	30-40	3.4-4.5	
13.....	30-40	3.4-4.5	
14.....	40-50	4.5-5.6	
16.....	30-40	3.4-4.5	

ACCESSORIES

LENGTH OF BAR	GUIDE BAR PART NUMBER	CHAIN PART NUMBER
12 in.....	PS06330	PS06328
14 in.....	PS06331	PS06329
16 in.....	PS06338	PS06285

SEALANT SILICON.....	PS24823	COMPRESSION TESTER.....	94194
*RUBBER TUBING	0745434	CARRY CASE	PA01648
WRENCH – COMBINATION	09207	BUMPER SPIKE KIT	984902001
DIGITAL TACHOMETER	18416	ADJUSTING PIN KIT.....	984901001
GREASE, MULTI-PURPOSE	18453	OPERATOR'S MANUAL.....	983000-406 983000-414

HOMELITE CONSUMER PRODUCTS, INC.

1428 Pearman Dairy Road, Anderson, SC. 29625

Post Office Box 1207, Anderson, SC 29622

Phone 1-800-242-4672

www.homelite.com

983000-406-414
03-22-04