

HOMELITE 42cc/46cc CHAIN SAWS – MODEL Nos. UT10517, UT10518 & UT10520

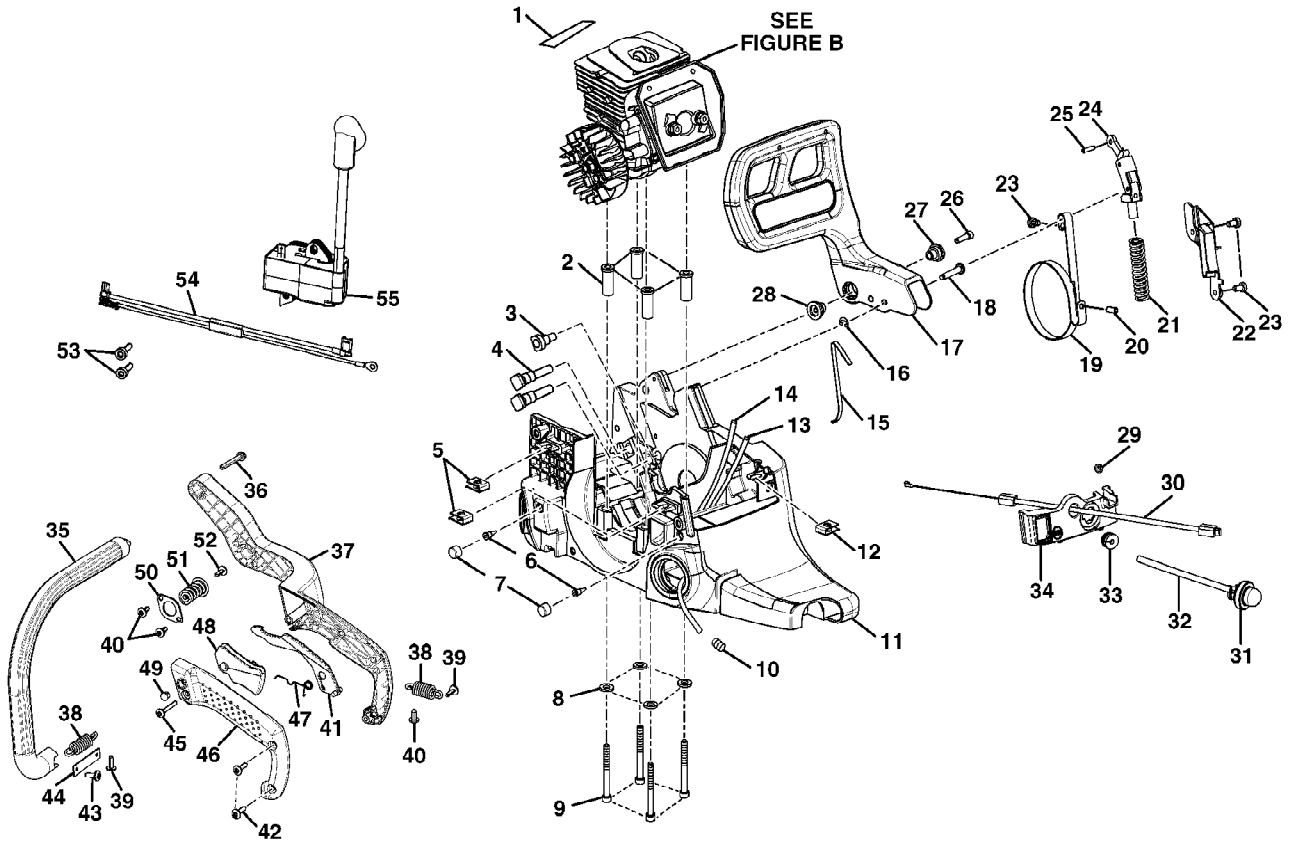

Figure A

42cc/46cc Chain Saw UT-10520  
Figure A

Page 2 of 8

Ref #	Part Number	Qty	S/P/F	Description
1	700106001	1		Heat Reflector Tape
2	671087001	4		Spacer Insert
3	570226001	1	S	Oil Outlet Grommet
4	660628001	2	S	Guide Bar Bolt
5	671077001	2	S	Speed Nut ("U"-type)
6	560955001	2	/P	Duck Bill Valve
7	671088001	2	/P	Element
8	671080001	4	/P	Washer
9	660622001	4	/P	Screw (10-24 x 2 in.) Purchase locally
10	690765001	1	/P	Hose Clamp
11	300951014	1		Chassis Assembly, Gray (UT10518/UT10520)
12	671077002	1		Speed Nut ("U"-type)
13	570247002	1	S	Rubber Tubing/07454-22
14	570247003	1	S	Rubber Tubing/07454-34
15	638024001	1	/P	Spring
16	671075001	1	S	Retaining Ring
17	511723111	1		Hand guard, Gray (UT10518/UT10520)
18	620282001	1	/P	Handguard Actuating Pin
19	631063002	1	S	Brake Band
20	671095001	1	/P	Spring Pin
21	678113001	1	S	Spring
22	511720002	1		Chain Brake Cover
23	660634001	3	/P	Screw (8-16 x 5/16 in.) Purchase locally
24	300954001	1	S	Chain Brake Link Assembly
25	671099001	1	S	Spring Pin (Small)
26	660635001	1	S	Screw (8-32 x 5/8 in.) Purchase locally
27	671096001	1	/P	Pivot (Right Hand)
28	671097001	1	/P	Pivot (Left Hand)
29	631034002	1		Hair Pin
30	900885001	1	/P	Throttle Cable
31	308088001	1	/P	Fuel Pump
32	570247004	1	S	Rubber Tubing
33	570227001	1	S	Split Grommet
34	518044012	1		Control Panel, Gray (UT10518/UT10520)
35	511724011	1		Front Handle, Gray (UT10518/UT10520)
36	660631001	1	S	Screw (12-14 x 1 1/2 in.) Purchase locally
37	511721014	1		Rear Handle, Gray (UT10518/UT10520)
38	671101001	2	S	Extension Spring
39	660632001	2	S	Screw (10-14 x 5/8 in.) Purchase locally
40	660618001	3	S	Screw (10-14 x 1/2 in.) Purchase locally
41	518051013	1		Lockout Throttle, Black (UT10518/UT10520)
42	660629001	2	S	Screw (10-14 x 3/4 in.) Purchase locally
43	660719001	1		Screw (10-14 Thread Twin Helix) Purchase locally
44	631050001	1	S	Spring Retainer
45	660633001	1	S	Screw (10-14 x 1 3/8 in.) Purchase locally
46	511722013	1		Handle Cover, Gray (UT10518/UT10520)
47	678037001	1	S	Torsion Ring
48	518052011	1		Trigger, Black (UT10518/UT10520)
49	518050011	1		Plug, Gray (UT10518/UT10520)
50	631051001	1		Isolator Plate

42cc/46cc Chain Saw UT-10520  
Figure A

Page 3 of 8

Ref #	Part Number	Qty	S/P/F	Description
51	671980001	1		Isolator Spring
52	660630001	1	/P	Screw (10-24 x 5/8 in.) Purchase locally
53	660639001	2	/P	Screw (8-32 x 5/8 in.) Purchase locally
54	290195003	1	/P	Ignition Switch Harness
55	300953001	1	S	Ignition Kit

HOMELITE 42cc/46cc CHAIN SAWS – MODEL Nos. UT10517, UT10518 & UT10520

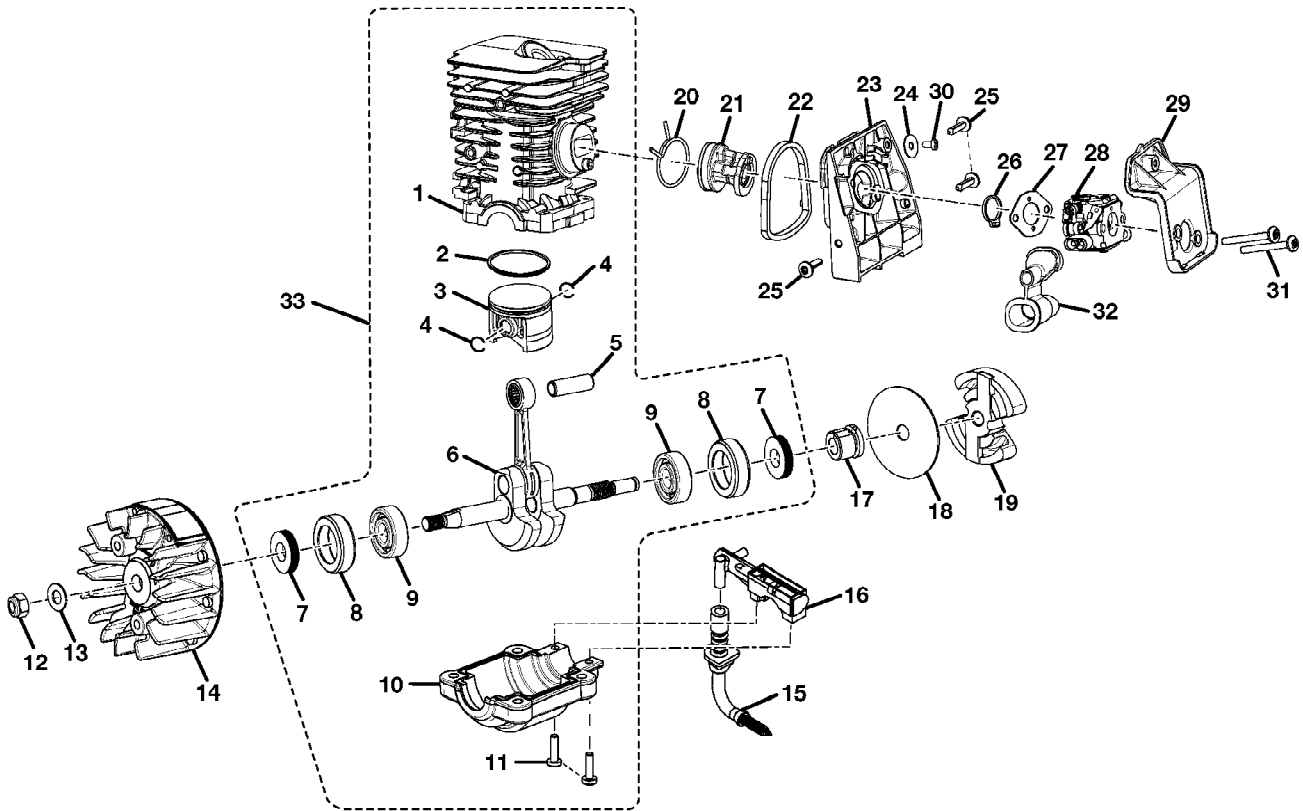

Figure B

42cc/46cc Chain Saw UT-10520  
Figure B

Page 5 of 8

Ref #	Part Number	Qty	S/P/F	Description
1	640200004	1		Cylinder
2	678747001	1		Piston Ring
3	640350002	1		Piston
4	678183001	2		Retaining Ring
5	620392001	1		Piston Pin
6	309160001	1		Crankshaft Assembly
7	570220001	2	/P	Shaft Seal
8	570221002	2		Bearing Case
9	671089002	2		Ball Bearing
10	640843001	1	S	Crankcase
11	660627001	2	S	Screw (8-32 x 5/8 in.) Purchase locally
12	678123001	1	/P	Nut (5/14-24)
13	631049001	1	S/P	Flat Washer
14	309012001	1		Flywheel Assembly
15	300950001	1	S	Oil Intake Tube Assembly
16	300945001	1	S	Oil Pump Assembly
17	610389001	1		Left Hand Worm
18	631061001	1	S	Thrust Washer
19	300960003	1	/P	Clutch Assembly
20	671267001	1	S	Wire Clamp
21	570243001	1	S	Intake Boot
22	518047001	1	S	Carburetor Adaptor Seal
23	308081001	1		Carburetor Adapter
24	671072001	1	S	Flat Washer
25	660629001	3	S	Screw (10-14 x 3/4 in.) Purchase locally
26	518045001	1	S	Carburetor Plate
27	900886001	1	S	Carburetor Gasket
28	309364001	1		Carburetor Assembly
29	518048001	1	S	Air Filter Base
30	660634001	1	/P	Screw (8-16 x 5/16 in.) Purchase locally
31	660655001	2		Screw (10-32 x 1 3/4 in.) Purchase locally
32	570242001	1	S	Grommet
33	309890003	1		Short Block Assembly (Inc. Key Nos. 1-11)

HOMELITE 42cc/46cc CHAIN SAWS – MODEL Nos. UT10517, UT10518 & UT10520

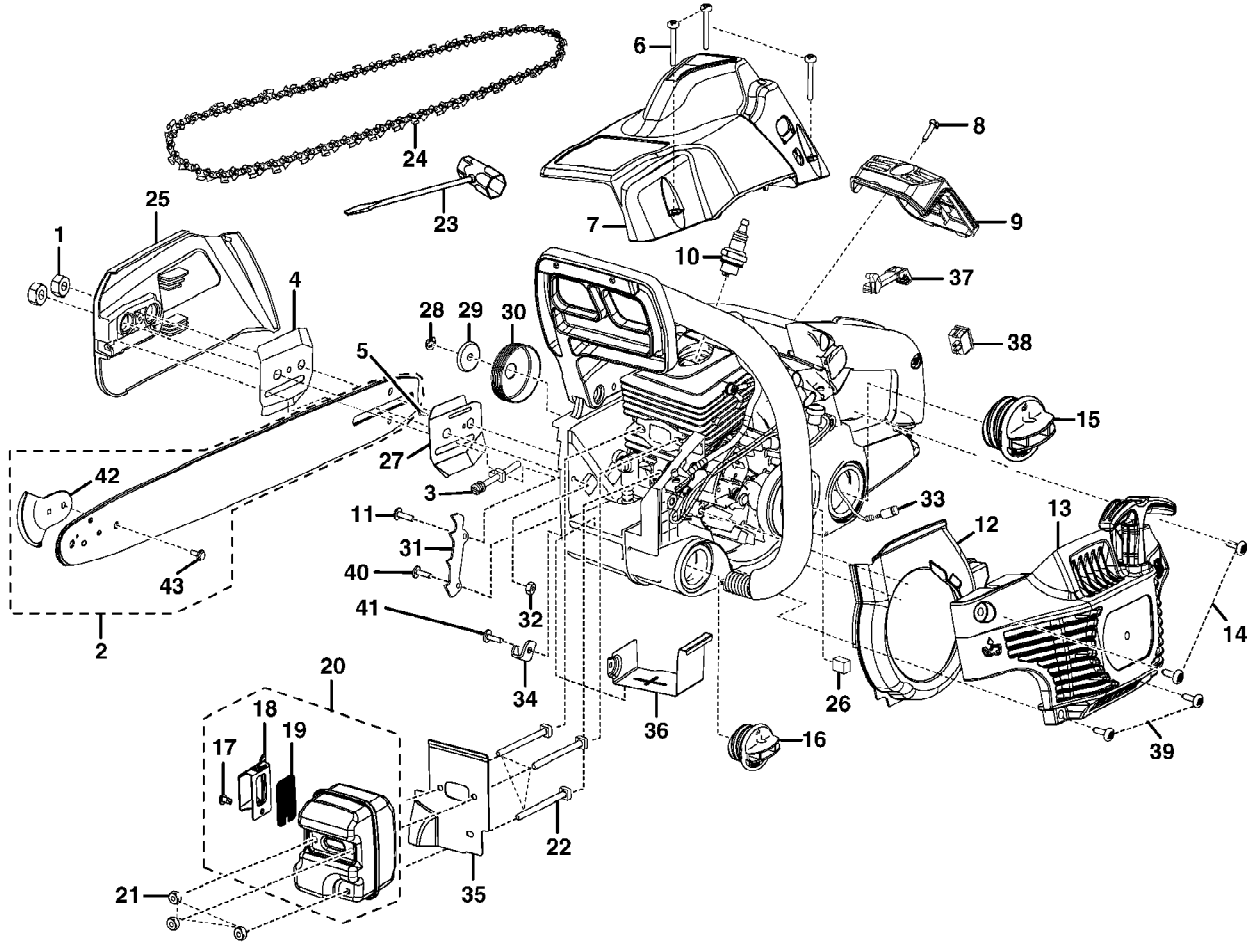

42cc/46cc Chain Saw UT-10520  
General Assembly

Page 7 of 8

Ref #	Part Number	Qty	S/P/F	Description
1	671076001	2	/P	Guide Bar Nut (5/16-18)
2	310629001	1	S	Guide Bar (UT10520 - 20 in. with SAFE-T-TIP) (Includes Key Nos. 42, 43)
3	308116001	1	/P	Guide Bar Adjustment Screw
4	631038001	1	S/P	Outer Guide Plate
5	660619001	1		Screw (6-19 x 1/2 in. T.F.) Purchase locally
6	660636001	3	/P	Screw (10-16 x 1-1/2 in. Special) Purchase locally
7	518042010	1		Top Cover, Red (UT10518/UT10520)
8	660617001	1	S	Screw (8-16 x 16 mm Torx T.F.) Purchase locally
9	518049002	1		Air Filter Cover
10	870174001	1	/P	Spark Plug (Champion RCJ6Y)
11	660625001	1	S	Screw (10-24 x 5/8 in. Torx Pan Hd.) Purchase locally
12	518055002	1		Fan Housing Baffle
13	308067004	1		Starter Cover Assembly
14	660632001	2	S	Screw (10-14 x 5/8 in., Truss Hd.) Purchase locally
15	300948002	1		Fuel Cap Assembly
16	300949002	1	S	Oil Cap Assembly
17	660624001	1	S	Screw (8-32 x 5/16 in.) Purchase locally
18	638467002	1		Outlet
19	638673001	1		Spark Screen
20	309310001	1		Muffler Assembly (Includes Key Nos. 17-19)
21	671079001	3	/P	Lock Nut (10-32) Purchase locally
22	660626001	3	/P	Muffler Bolt (Square Hd.)
23	631055001	1	S	Combination Wrench
24	900920027	1	S	Chain (UT10520 - .325 x 58 link, 20 in.)
25	300957015	1		Chain Cover Assembly
26	900844001	1	S	Pre-Filter
27	631036001	1	S	Inner Guide Plate
28	671103001	1	S	E-Ring
29	631060001	1	S	Cupped Washer
30	300958002	1		Sprocket Drum and Bearing Assembly (UT10518/UT10520 - .325 chain)
31	631039001	1	S	Spike Bar
32	678027002	1	S	Lock Nut (10-24) Purchase locally
33	300759005	1		Fuel Filter
34	631035001	1	S	Chain Catcher
35	900894001	1		Muffler Gasket
36	638455001	1		Heat Shield
37	511709012	1		Choke Lever, Black (UT10518/UT10520)
38	760338001	1	S	Ignition Switch
39	660637001	2	S	Screw (10-14 x 7/8 in., Truss Hd.) Purchase locally
40	660621001	1	S	Screw (10-24 x 1/2 in.) Purchase locally
41	660618001	1	S	Screw (10-14 x 1/2 in.) Purchase locally
42	308944001	1		Safety Tip (UT10518/UT10520)
43	660640001	1		Screw (Hex Head)

42cc/46cc Chain Saw UT-10520  
General Assembly

Page 8 of 8

Ref #	Part Number	Qty	S/P/F	Description
44	518061001	1		Scabbard (UT10520, Not Shown)
	987000210	1		Operator's Manual (960970011)