

# Stick Edger



# Owner's Manual

---

Model GE25 - UT26102

first edition

PNPS00955

**GreenMachine**<sup>®</sup>  
*Engineered for Survival*

P.O. Box 7047  
Charlotte, NC 28241

# ▲ WARNING ▲

The engine exhaust from this product contains chemicals known to the State of California to cause cancer, birth defects or other reproductive harm.  
CALIFORNIA PROPOSITION 65

*Thank you for buying this new GREEN MACHINE® Stick Edger! GREEN MACHINE® provides a wide range of Lawn and Garden, Forestry, and Construction Equipment products which meet the needs of both the consumer and commercial markets. GREEN MACHINE® products are warranted and are serviced by a large network of servicing dealers.*

## CUSTOMER ASSISTANCE

FOR THE LOCATION OF YOUR NEAREST GREEN MACHINE® SERVICING DEALER IN THE UNITED STATES, PUERTO RICO, AND THE VIRGIN ISLANDS, CALL: 1-800-242-4672.

- **SYMBOL DEFINITION**
- **SAFETY INSTRUCTIONS**
- **PREPARING FOR USE**
- **OPERATION**
- **MAINTENANCE AND ADJUSTMENT**
- **STORAGE**
- **TROUBLE SHOOTING**
- **PRODUCT INFORMATION**
- **WARRANTY**

## SYMBOL DEFINITION



Indicates Warning, Danger, and Caution.



Keep all bystanders at least 50 feet (15m) away.



Read all Safety, Operating and Maintenance Instructions.



Danger of Ricochet.



Wear eye and hearing protection when operating this equipment.



Keep hands and feet away from blades when they are moving.

## SAFETY INSTRUCTIONS



**FOR SAFE OPERATION, READ THESE INSTRUCTIONS BEFORE USING YOUR STICK EDGER. FOLLOW ALL INSTRUCTIONS FOR SAFETY.**

**WARNING: UNIT MAY START QUICKLY! KEEP YOUR BODY AWAY FROM BLADE. KEEP BYSTANDERS AWAY.**

### GENERAL INSTRUCTIONS

- **DO NOT ALLOW CHILDREN OR UNTRAINED INDIVIDUALS TO USE THIS UNIT.**
- Operators must be in good physical condition. Operating equipment can cause fatigue. Perform all work calmly and with caution.
- Use this edger for edging along sidewalks, driveways, flower beds and similar areas. Do not use for any other purpose.
- Ensure area is secure from other people and animals. Do not allow children to play within 50 feet (15 meters) of work area.
- Never start or run the engine inside a closed area; breathing exhaust fumes can kill.
- Clear the work area before each use. Remove all objects such as rocks, broken glass, nails, wire, or other obstacles which can be thrown or become entangled with the blade.
- Do not operate equipment after consuming alcohol, medication, or drugs. Do not operate equipment if feeling ill or fatigue.
- **PRODUCT USERS ON UNITED STATES FOREST SERVICE LAND, AND IN SOME STATES, MUST COMPLY WITH FIRE PREVENTION REGULATIONS. THIS PRODUCT IS EQUIPPED WITH A SPARK ARRESTOR; HOWEVER, OTHER USER REQUIREMENTS MAY APPLY. CHECK WITH YOUR FEDERAL, STATE, OR LOCAL AUTHORITIES.**

### PROTECTIVE CLOTHING

- **Wear full eye and hearing protection when operating equipment.**
- Always wear protective clothing to reduce the risk of injury.
- Wear long pants, work shoes, and gloves. Do not wear loose fitting clothes or jewelry.
- Secure long hair so that it is above or behind the shoulder.

### OPERATING SAFETY

- Regular maintenance should be performed to ensure safe operation of equipment.
- Do not operate in poor lighting.
- Keep firm footing and balance. Do not overreach.
- Keep all body parts away from blade and hot surfaces.
- **ALWAYS STOP ENGINE AND REMOVE SPARK PLUG WIRE BEFORE MAKING ANY ADJUSTMENTS OR REPAIRS EXCEPT CARBURETOR ADJUSTMENTS.**

### BLADE SAFETY

- After engine stops, keep rotating blade in heavy grass or brush until it stops.
- Always hold unit firmly with both hands.
- Do not operate edger unless debris deflector and blade guard are in place.
- Always stop the engine before attempting to remove any obstruction caught or jammed in the blade.
- Do not attempt to touch or stop the blade while it is rotating.
- A coasting blade can cause injury while it continues to spin after the engine is stopped or throttle trigger is released. Maintain proper control until the blade has completely stopped rotating.
- Always make sure blade is installed correctly and securely fastened before each use.
- Use sharp blades - replace any blade that has been damaged or is no longer sharp.
- Use only Green Machine® blades intended for use on this brush cutter. **DO NOT USE ANY OTHER BLADE.**
- Always wear heavy gloves while installing or removing blades.

## **SAFETY INSTRUCTIONS**

### **MAINTENANCE**

- Use only GREEN MACHINE® replacement parts. Failure to do so may cause poor performance, possible injury and may void your warranty.
- Inspect unit before each use for loose fasteners, fuel leaks, etc. Replace damaged parts. Replace blade if cracked, chipped, or damaged in any way.
- Make sure all deflectors and handles are properly and securely attached.
- Before storing, allow the engine to cool.
- Empty the fuel tank and secure the edger to prevent it from moving before transporting in a vehicle.

### **REFUELING (DO NOT SMOKE!)**

- Mix and store fuel in a container approved for gasoline.
- Mix fuel outdoors where there are no sparks or flames. Ensure air ventilation.
- Select bare ground, stop engine, and allow to cool before refueling.
- Loosen fuel cap slowly to release pressure and to keep fuel from escaping around the cap.
- Wipe spilled fuel from the unit. Move 10 feet (3 meters) away from refueling site before starting engine.

**PREPARING FOR USE**

**ASSEMBLY INSTRUCTIONS:**

The GE25 Stick Edger comes assembled with the exception of the wheel and the debris deflector.



**Make sure unit is stopped when installing or adjusting the wheel assembly.**

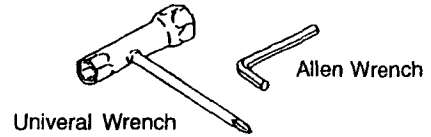

**Tools Required for Assembly**

A universal wrench and allen wrench are included for assembly of handles, blade guard, and grass deflector.

1. Mount the wheel on the Lawn Edger as shown. Tighten the bolt to secure. Do not overtighten.

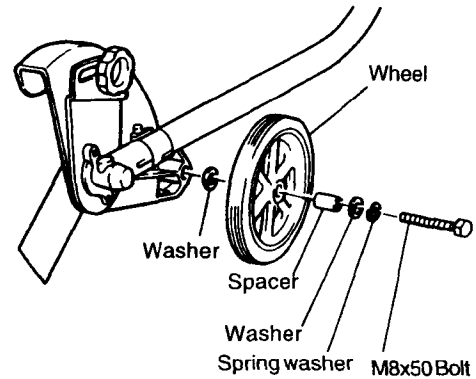

2. Attach the debris deflector to the hook on the backside of the blade cover. Tighten the screw to secure the debris deflector. Do not overtighten.

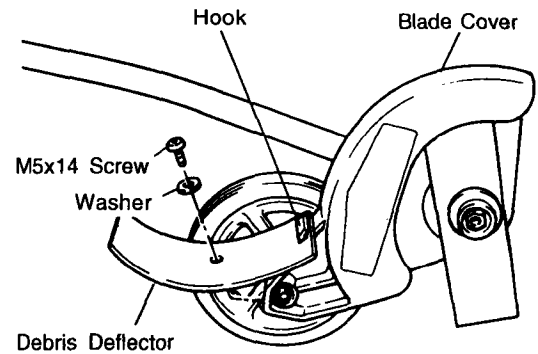

**PREPARING FOR USE**

**FUELING**

This product is powered by a 2-cycle engine and requires pre-mixing gasoline and 2-cycle oil. Pre-mix unleaded gasoline and 2-cycle engine oil in a clean container approved for gasoline.

**RECOMMENDED FUEL:** THIS ENGINE IS CERTIFIED TO OPERATE ON UNLEADED GASOLINE INTENDED FOR AUTOMOTIVE USE.

Mix Green Machine® Premium Exact Mix™ Oil with gasoline according to the instructions on the package. If Green Machine® Premium Exact Mix™ oil is not available, use a high quality 2-cycle engine oil, mixed at 2.6 oz. per gallon (US).

DO NOT USE AUTOMOTIVE OIL OR 2-CYCLE OUTBOARD OIL.

**NOTE:** Green Machine® Premium Exact Mix™ fuel mix will stay fresh up to 30 days. DO NOT use fuel mix that is more than 30 days old or engine may not start.



<b>Gasoline</b>	<b>Oil</b>
1 gallon (US)	2.6 oz.
1 Liter	20cc

**FUEL MIXTURE**

**GREEN MACHINE® PREMIUM EXACT MIX™ (50:1)**

Green Machine® Premium Exact Mix™ one pint bottle is the best value and the easiest to use.

Pour about 1/2 the required amount of gasoline into container. Add the required amount of oil to the gasoline. Close and shake the container vigorously. Add the remaining gasoline, and shake again until completely mixed. Serious engine damage can result with inadequately mixed fuel.



Never attempt to mix fuel in the unit fuel tank.



Do not attempt to fuel the unit near an open flame or unventilated area.

**FILLING TANK**

1. Loosen fuel cap slowly.
2. Carefully pour fuel into the tank. Avoid spillage.
3. Immediately replace fuel cap and hand tighten. Wipe up any fuel spillage.

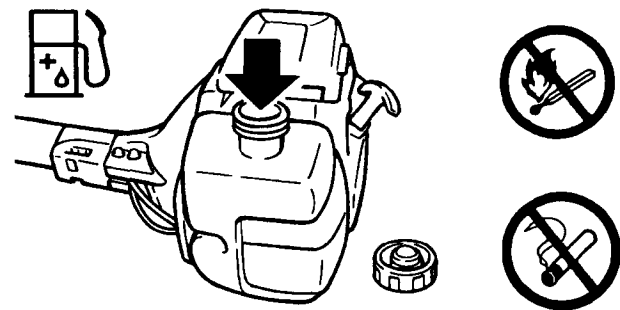

Always shut off engine before fueling. Never add fuel to a machine with a running or hot engine. Move at least 10 feet (3 meters) from refueling site before starting engine. **DO NOT SMOKE!**

**OPERATION**

**STARTING AND STOPPING**



Read, understand, and observe all safety instructions when fueling, starting and operating this equipment. Ensure unit is safe for operation. Perform daily maintenance check.

**STARTING**

Move at least 10 feet (3 meters) away from fueling area. Carefully place unit on a clean piece of ground.

**NOTE: Ensure that cutting tool does not encounter the ground or any other objects during initial start. Ensure the safety of others in the work area.**

**Cold Start**

1. Push the ON-OFF (I-O) switch in the direction of the arrow to the on (I) position.
2. Grasp the handle. Hand pressure activates the safety lock.
3. Squeeze the throttle lever and hold it.
4. Press the throttle lock and release the throttle lever. This will lock the throttle into position.
5. Push the primer button several times until fuel is visible in the transparent primer bulb.
6. Move the choke lever to the closed (  ) position.
7. Firmly hold the unit with left hand.
8. Slowly pull the starter grip until resistance is felt and continue with a firm pull. Do not pull starter cord fully.
9. Do not let cord snap back as this can damage starter.
10. Repeat the starting procedure until engine attempts to start.
11. Move the choke lever to the open position (  ) and pull the starter rope until the engine starts.
12. Immediately squeeze and release the throttle lever to release the throttle lock so that the engine can run at idle. Allow engine to warm enough to idle smoothly.

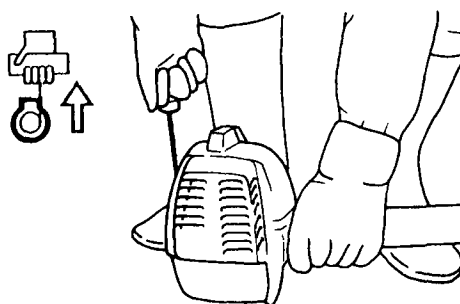
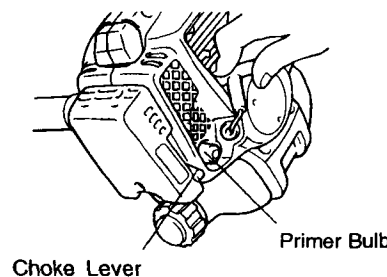
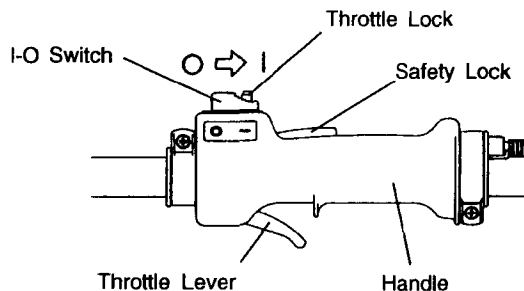

**Do not run engine at full throttle in a no-load operation. Never operate the engine at a higher speed than required or more than 6,000 - 8,000 rpm.**

**Starting a Warm Engine**

Use same procedure as above, except leave choke lever in open position (  ). Re-priming the fuel system should not be necessary.

**STOPPING**

**Warning:** Familiarize yourself with the stopping procedure in case of an emergency.

Release the throttle lever fully. When engine rpm has slowed, push the ON-OFF (I-O) switch to OFF (O) position. The engine will now stop.

**OPERATION****USING THE LAWN EDGER**

Ensure work area is cleared of debris such as rocks, stones, nails, etc. Such items can be thrown by the blade.

Be cautious of other potential hazards that could damage equipment.

Ensure safe footing for all operations.

Prepare work area by removing debris and other hazards. Protect surrounding area from incidence of thrown debris. Use care in directing edger discharge to avoid glass enclosures, windows, automobiles, etc.

Water the area to soften ground. This will make edging easier. Plan to edge regularly to maintain a neat edge and to avoid the need for more than one pass.

Hold the edger firmly with both hands. The right hand will hold the rear handle; the left hand will hold the front guide handle. Keep fingers curled around handles to maintain a firm grip. This will ensure the operator is in control of the unit at all times.



Never attempt to operate the edger with one hand.

Plan edging direction of travel before starting. Make sure that path will accommodate the operator and the edger, and that the edger is always positioned on the right side. The operator should have a hard, sturdy surface to walk along whenever possible.

To begin edging, increase engine speed by squeezing the throttle and lower the blade gently into the ground. Do not operate the engine at a higher speed than is necessary to complete the project. Maintain an approximate speed of 6,000 to 8,000 rpm. Be careful not to hit concrete or other hard surfaces with the blade.

**Blade Depth**

Blade depth may need to be adjusted due to the difference in height between the hard surface and the top of the grass. Blade depth should be adjusted to produce a fine cut between the hard surface and the grass. Approximately 1/2" of the blade should enter the ground.

To adjust the blade depth of cut:

1. Stop the engine if running. Place the unit on a level surface and remove spark plug cap.
2. Make sure that the blade has stopped rotating.
3. Loosen the adjustment knob.
4. Move the blade cover toward back of edger to reduce depth.
5. Move the blade cover toward front of edger to increase depth.
6. Retighten the adjustment knob.

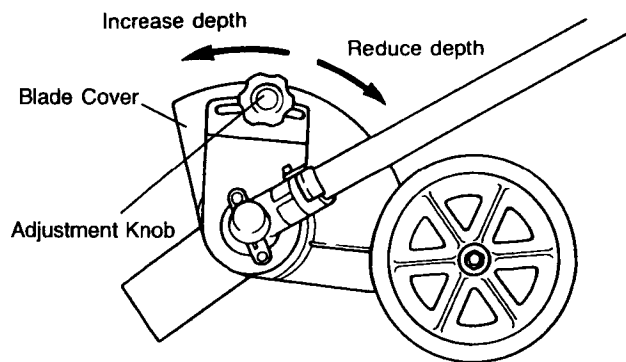



**MAINTENANCE AND ADJUSTMENT**

**IDLE ADJUSTMENT**

The blade should not rotate when the throttle lever is fully released (engine idle). If necessary, adjust idle speed using the adjusting screw.

**NOTE:** Idle speed should be set at 2,600 rpm.

**To adjust:**

1. Locate the idle adjusting screw on backside of engine near choke lever.
2. Turn screw **clockwise** to **increase** the engine idle speed.
3. Turn screw **counter-clockwise** to **decrease** the engine idle speed.

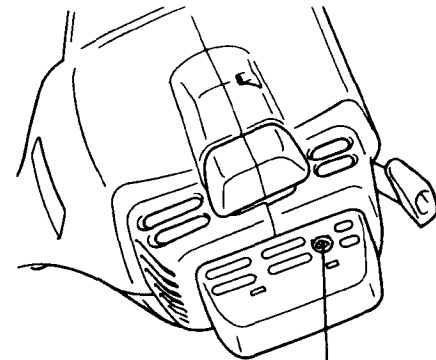

Idle adjusting screw

**BLADE REPLACEMENT & INSPECTION**



**Stop engine and shut off equipment before replacing or inspecting blades. Do not attempt to bend or weld blade. Replace blade if damaged.**

**BLADE REPLACEMENT**



**Always wear heavy gloves while installing, removing or inspecting blades.**

1. Insert allen wrench through hole in gear case and rotate the receiver washer until it is locked with the allen wrench.
2. Loosen the nut with the universal wrench by turning clockwise, remove the nut and clamp washer. Remove old blade and replace with new blade. Replace clamp washer.
3. With the allen wrench still in place, install the clamp washer and nut. Turn nut counter-clockwise with socket wrench to tighten securely.
4. Remove allen wrench for free rotation.

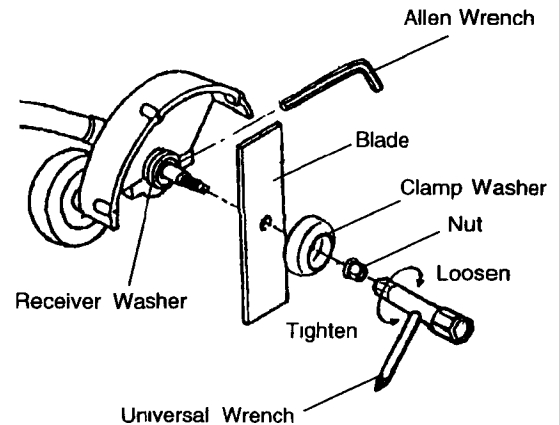

**ROUTINE MAINTENANCE SCHEDULE**

Always stop the engine and pull off the spark plug cap before inspecting the unit.

**Daily (every 8 hours)****Prior to Use**

1. Check the unit for loose screws or missing parts. Pay particular attention to the tightness of the blade.
2. **Check fuel cap.**  
**A LEAKING FUEL CAP IS A FIRE HAZARD AND MUST BE REPLACED IMMEDIATELY.**
3. **Check clogging of the cooling air passages** and the cylinder fins. Clean them if necessary.
4. Inspect the air filter.

**NOTE: A clogged air filter may make it difficult or impossible to start the engine. Engine damage may result due to increased rotation speed. Inspect and clean air filter daily.**

If working under dusty conditions, repeat this procedure several times during work session.

**5. Check spark plug.**

Remove spark plug cover.

The gap between the two electrodes of the spark plug should be 0.024 to 0.028 inches (0.6 to 0.7 mm). If the spark plug is clogged with carbon or fouled, replace it.

**6. Inspect the fuel filter.**

If the filter appears to be hardened, polluted or clogged, replace immediately.

**Following Use**

1. Clean the string trimmer externally and inspect for damage.
2. Check the string head for damage and make sure it is firmly mounted.
3. Clean the air filter.

Pull out on bottom of air filter cover to remove.

Move the choke lever to the closed () position to prevent dirt particles from entering the carburetor.

Remove the air filter, wash in lukewarm water and allow to dry completely.

Reinstall air filter. Replace air filter cover.

**NOTE: If there is excessive dust or dirt adhering to the air filter, clean it every day. A clogged air filter may make it difficult or impossible to start the engine or increase the engine RPMs.**

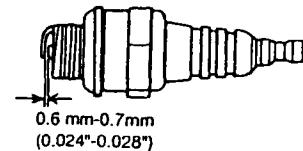
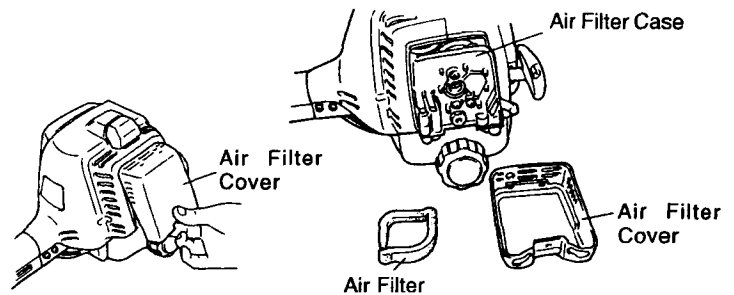

**Weekly (every 30 hours)****Greasing the gear case**

Apply grease (SHELL ALVANIA No. 3 or equivalent) to the gear case through the grease hole every 30 hours.

**Greasing the flexible shaft**

Pull the flexible shaft out of the drive shaft housing and apply grease (SHELL ALVANIA No. 3 or equivalent). Carefully slide the flexible shaft back into drive shaft housing.

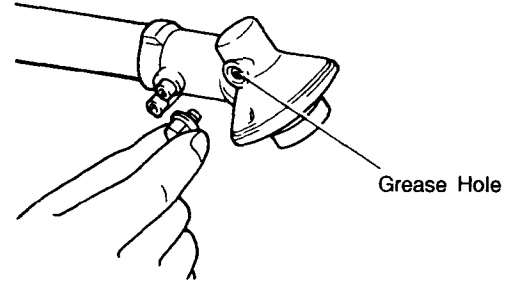
**Monthly****1. Fuel Filter in Fuel Tank**

A periodic visual inspection of the fuel filter is required.

Open the tank. Drain all fuel from the tank into a container approved for gasoline. **DO NOT SMOKE.** Use a wire hook to pull out the filter through the tank opening.

Inspect filter. Filters found to have hardened, been polluted or clogged, replace immediately.

Insufficient fuel supply can result in the admissible maximum speed being exceeded. Replace the fuel filter at least quarterly to ensure satisfactory fuel supply to the carburetor.

**2. Clean Muffler Exhaust Port**

Check muffler exhaust port regularly. The exhaust port can become clogged with carbon. Remove the carbon by scraping and tapping gently with a screwdriver or similar tool.

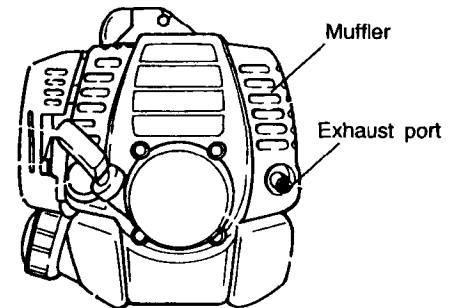

**Do not allow carbon particles to enter into engine ports.**

**Annually (200 hours)**

1. Replace fuel lines.
2. Replace spark plugs.
3. Spark Arrestor Screen Maintenance.

This engine is equipped with a Spark Arrestor Screen. This may become clogged after many hours of use. It is recommended that this screen be cleaned by an authorized servicing dealer.

**STORAGE (1 month or longer)**

1. Remove the tank cap and remove the filter. Depress the primer bulb several times until all fuel is expelled from the primer bulb. Drain all fuel from tank into a container approved for gasoline. Run engine until it stops.
2. Remove the spark plug and add a few drops of oil into the spark plug hole. Pull the starter gently so that oil is distributed throughout the engine. Replace and tighten spark plug.
3. Clean all foreign material from the edger. Wipe down with an oil-immersed cloth. Store it in a well-ventilated, dry place that is inaccessible to children. Keep away from corrosive agents such as garden chemicals and de-icing salts.
4. Abide by all federal and local regulations for the safe storage and handling of gasoline. Excess fuel should be used in other 2-cycle engine powered equipment.

**TROUBLE SHOOTING**

**IF THESE SOLUTIONS DO NOT SOLVE THE PROBLEM CONTACT YOUR AUTHORIZED SERVICING DEALER.**

FAULT	SYSTEM	OBSERVATION	CAUSE
Engine not starting or starts with difficulty	Ignition system	Ignition spark O.K.	Fault in fuel supply in compression system, mechanical defect.
		No ignition spark	ON-OFF (I-O) switch may be in OFF (O) position, wiring fault or short circuit, spark plug or connector defective, ignition module faulty.
	Fuel supply	Fuel tank filled	Incorrect choke position, carburetor defective, fuel supply line bent or blocked, fuel dirty.
	Compression	No compression when pulled over	Cylinder bottom gasket defective, crankshaft seals damaged, cylinder or piston rings defective or improper sealing of spark plug.
	Mechanical fault	Starter not engaging	Broken starter spring, broken parts inside of the engine.
Warm start problems		Tank filled, ignition spark existing	Carburetor contaminated. Must be cleaned.
Engine starts but dies immediately	Fuel supply	Tank filled	Incorrect idling adjustment, carburetor contaminated.
			Fuel tank vent defective, fuel supply line interrupted, cable or STOP-switch faulty.
Insufficient performance	Several systems may simultaneously be affected	Poor engine idle	Air filter contaminated, carburetor contaminated, muffler clogged, exhaust port in the cylinder clogged.

**PRODUCT INFORMATION**

<b>Model</b>		<b>GE25</b>
Dimensions (l x w x h) Without cutting blade	inch (mm)	67 5/16"x12 19/32"x11 19/32" (1710mmx320mmx295mm)
Weight (without protector and cutting blade)	lb (kg)	10.7 lb (4.9 kg)
Tank Size	liter	0.5
Engine Output	cc	24.5 cc
Maximum Engine Performance	HP (kw) @rpm	0.98(0.73) @ 7000
Engine Speed at Recommended Maximum Spindle Speed	rpm	6000-8800
Revolution of Cutter Head	rpm	6000
Idling Speed	rpm	2600
Carburetor	type	Primer Bulb
Ignition System	type	Solid State Ignition
Spark Plug	type	NGK BM7A
Electrode Gap	in (mm)	0.024"-0.028" (0.6mm-0.7mm)
Fuel (gasoline: two-stroke oil)		Mixed Gas 50:1

The manufacturer warrants to the original retail purchaser that this Product is free from defects in material and workmanship and agrees to repair or replace, at Manufacturer's discretion, any defective product free of charge within one year from the date of purchase

This warranty is not transferable and does not cover damage resulting from defects other than in material or workmanship, or damage caused by unreasonable use, including the failure to provide reasonable and necessary maintenance. Also, the warranty obligations do not apply to conditions resulting from misuse, alteration or accident. In addition, this warranty does not cover general check-ups on electrical equipment, tune-ups on gasoline engines, or replacement of non-defective parts (such as electrical brushes, cables, plugs, spark plug, filters, starter ropes, etc.) that may wear and need to be replaced with reasonable use within the warranty period or which may require replacement in connection with normal maintenance. This warranty applies only to products sold within the United States of America, the District of Columbia, Canada, Mexico, the Commonwealth of Puerto Rico, the Virgin Islands, Guam, the Canal Zone, or American Samoa

#### **SAVE YOUR SALES SLIP**

Proof of purchase in the form of your dated sales receipt, cash register slip, etc. showing the serial number and the model of your Product will be required before our dealers can perform warranty service on the Product. You must at your own expense, arrange to deliver or ship the Product for warranty repairs and arrange for pickup or return of the Product after repairs have been made.

This warranty does not apply to any trade accessory, engine, or electric motor which is separately warranted by another manufacturer and not manufactured by the manufacturer.

**THIS LIMITED WARRANTY IS IN LIEU OF ALL OTHER EXPRESS WARRANTIES. ANY IMPLIED WARRANTY OF FITNESS FOR A PARTICULAR PURPOSE, MERCHANTABILITY OR OTHERWISE, APPLICABLE TO THIS PRODUCT, SHALL BE LIMITED IN DURATION TO THE DURATION OF THIS LIMITED WARRANTY. THE MANUFACTURER SHALL NOT BE LIABLE FOR ANY SPECIAL, INCIDENTAL OR CONSEQUENTIAL DAMAGES.**

**SOME STATES DO NOT ALLOW LIMITATIONS ON HOW LONG AN IMPLIED WARRANTY LASTS, SO THE ABOVE LIMITATION MAY NOT APPLY TO YOU. ALSO, SOME STATES DO NOT ALLOW THE EXCLUSION OR LIMITATION OF INCIDENTAL OR CONSEQUENTIAL DAMAGES, SO THE ABOVE LIMITATION OR EXCLUSION MAY NOT APPLY TO YOU.**

#### **HOW TO OBTAIN WARRANTY SERVICE**

Warranty service can be obtained from a Green Machine® dealer authorized to make warranty repairs. If you need warranty service, check first with the dealer from whom you purchased the Product. FOR WARRANTY SERVICE INFORMATION OUTSIDE THE USA AND CANADA, PLEASE CONTACT YOUR LOCAL GREEN MACHINE® DEALER.

The manufacturer will not make any reimbursements for warranty service, except to Green Machine® dealers authorized to make warranty repairs. You must present your sales receipt when making any claim for warranty service.

This warranty gives you specific legal rights, and you may also have other rights which vary from state to state

This warranty is given by John Deere Consumer Products, Inc. Post Office Box 7047, Charlotte, North Carolina 28241

**FEDERAL EMISSION COMPONENT DEFECT WARRANTY**

**EMISSION COMPONENT DEFECT WARRANTY COVERAGE** - This emission warranty is applicable in all States, except the State of California.

John Deere Consumer Products, Inc., - Charlotte, North Carolina (herein "JDPCP") warrants to the initial retail purchaser and each subsequent owner, that this utility/lawn/garden equipment engine (herein "engine") has been designed, built, and equipped to conform at the time of initial sale to all applicable regulations of the U.S. Environmental Protection Agency (EPA), and that the engine is free of defects in materials and workmanship which would cause this engine to fail to conform with EPA regulations during its warranty period.

For the components listed under PARTS COVERED, the -dealer or service center authorized by JDPCP will, at no cost to you make the necessary diagnosis, repair, or replacement necessary to ensure that the engine complies with applicable U.S. EPA regulations.

**EMISSION COMPONENT DEFECT WARRANTY PERIOD**

The warranty period for this engine begins on the date of sale to the initial purchaser and continues for a period of 2 years.

**PARTS COVERED**

Listed below are the parts covered by the Emission Component Defect Warranty. Some of the parts listed below may require scheduled maintenance and are warranted up to the first scheduled replacement point for that part.

- |                                       |  |
|---------------------------------------|--|
| 1) Fuel Metering System               | 3) Ignition System                           |
| (i) Carburetor and internal parts     | (i) Spark plug                               |
| (ii) Fuel filter, if applicable       | (ii) Flywheel magneto                        |
| (iii) Throttle stopper, if applicable | (iii) Ignition coil                          |
| (iv) Choke system, if applicable      |  |
| 2) Air Induction System               | 4) Miscellaneous Items Used in Above Systems |
| (i) Air cleaner plate                 | (i) Fuel hoses and sealing gaskets           |
| (ii) Air cleaner case                 |  |
| (iii) Air cleaner element             |  |

**OBTAINING WARRANTY SERVICE**

To obtain warranty service, take your engine to the nearest authorized Green Machine®, distributor or dealer. Bring your sales receipts indicating date of purchase for this engine.

The dealer or service center authorized by JDPCP, will perform the necessary repairs or adjustments within a reasonable amount of time and furnish you with a copy of the repair order.

All parts and accessories replaced under this warranty become the property of JDPCP.

**WHAT IS NOT COVERED**

- \* Conditions resulting from tampering, misuse, improper adjustment (unless they were made by the dealer or service center authorized by JDPCP during a warranty repair), alteration, accident, failure to use the recommended fuel and oil, or not performing required maintenance services.
- \* The replacement parts used for required maintenance services.
- \* Consequential damages such as loss of time, inconvenience, loss of use of the engine or equipment, etc.
- \* Diagnosis and inspection charges that do not result in warranty-eligible service being performed.
- \* Any non-authorized replacement part, or malfunction of authorized parts due to use of non-authorized parts.

**OWNER'S WARRANTY RESPONSIBILITIES**

As the engine owner, you are responsible for the performance of the required maintenance listed in your owner's manual. JDPCP recommends that you retain all receipts covering maintenance on your engine, but JDPCP can not deny warranty solely for the lack of receipts or for your failure to ensure the performance of all scheduled maintenance.

As the engine owner, you should however be aware that the JDPCP may deny your warranty coverage if your engine or a part has failed due to abuse, neglect, improper maintenance or unapproved modifications.

You are responsible for presenting your engine to the nearest dealer or service center authorized by JDPCP when a problem exists. If you have any questions regarding your warranty rights and responsibilities, you should contact the John Deere Consumer Products, Inc. Customer service department at 1-704-588-3200 for the information.

## **EMISSION CONTROL SYSTEM WARRANTY**

### **THINGS YOU SHOULD KNOW ABOUT THE EMISSION CONTROL SYSTEM WARRANTY MAINTENANCE AND REPAIRS**

You are responsible for the proper use and maintenance of the engine. You should keep all receipts and maintenance records covering the performance of regular maintenance in the event questions arise. These receipts and maintenance records should be transferred to each subsequent owner of the engine. JDCP reserves the rights to deny warranty coverage if the engine has not been properly maintained. Warranty claims will not be denied, however, solely because of the lack of required maintenance or failure to keep maintenance records.

**MAINTENANCE, REPLACEMENT OR REPAIR OF EMISSION CONTROL DEVICES AND SYSTEMS MAY BE PERFORMED BY ANY REPAIR ESTABLISHMENT OR INDIVIDUAL; HOWEVER, WARRANTY REPAIRS MUST BE PERFORMED BY A Green Machine® DEALER OR SERVICE CENTER AUTHORIZED BY JDCP. THE USE OF PARTS THAT ARE NOT EQUIVALENT IN PERFORMANCE AND DURABILITY TO AUTHORIZED PARTS MAY IMPAIR THE EFFECTIVENESS OF THE EMISSION CONTROL SYSTEM AND MAY HAVE A BEARING ON THE OUTCOME OF A WARRANTY CLAIM.**

If other than the parts authorized by JDCP are used for maintenance replacements or for the repair of components affecting emission control, you should assure yourself that such parts are warranted by their manufacturer to be equivalent to the parts authorized by JDCP in their performance and durability.

### **HOW TO MAKE A CLAIM**

All repairs qualifying under this limited warranty must be performed by a Green Machine® dealer or service center authorized by JDCP. In the event that any emission-related part is found to be defective during the warranty period, you shall notify John Deere Consumer Products customer service department at 1-704-588-3200 and you will be given the appropriate warranty service facilities where the warranty repair can be performed.



**EMISSION CONTROL SYSTEM WARRANTY STATEMENT**

**CALIFORNIA EMISSION CONTROL  
WARRANTY STATEMENT  
YOUR WARRANTY RIGHTS AND OBLIGATIONS**

The California Air Resources Board and John Deere Consumer Products, Inc. (herein "JDCP") are pleased to explain the emission control system warranty on your 1998 and later utility and lawn and garden equipment engine (herein "engine"). In California, the engine must be designed, built and equipped to meet the State's stringent anti-smog standards. JDCP must warrant the emission control system on your engine for the periods of time described below, provided there has been no abuse, neglect or improper maintenance of your engine.

Your emission control system may include parts such as the carburetor and the ignition system. Also included may be hoses, connectors and other emission-related assemblies.

Where a warrantable condition exists, JDCP will repair your engine at no cost to you including diagnosis, parts and labor.

**MANUFACTURER'S WARRANTY COVERAGE:**

The 1998 and later engines are warranted for two (2) years. If any emission related part on your engine is defective, the part will be repaired or replaced by JDCP.

**OWNER'S WARRANTY RESPONSIBILITIES:**

-As the engine owner, you are responsible for the performance of the required maintenance listed in your Owner's Manual. JDCP recommends that you retain all receipts covering maintenance on your engine, but JDCP cannot deny warranty solely for the lack of receipts or for your failure to ensure the performance of all scheduled maintenance.

-As the engine owner, you should be aware however, that JDCP may deny you warranty coverage if your engine or a part has failed due to abuse, neglect, improper maintenance or unapproved modifications.

-You are responsible for Presenting your engine to a dealer, distributor or warranty station authorized by John Deere Consumer Products, Inc., Post Office Box 7047, Charlotte, North Carolina 28241 (herein "JDCP") as soon as a problem exists. The warranty repairs should be completed in a reasonable amount of time, not to exceed 30 days.

If you have any questions regarding your warranty rights and responsibilities, you should contact the John Deere Consumer Products, Inc. customer service department at 1-704-588-3200.

**LIMITED WARRANTY  
on Emission Control Systems  
- California Only -**

John Deere Consumer Products, Inc., Charlotte, North Carolina warrants to the owner of the 1998 and later engine that the engine (1) has been designed, built and equipped so as to conform at the time of manufacture with the applicable regulations of the California Air Resources Board, and (2) is free from defects in materials and workmanship which could cause it to fail to conform with those regulations as may be applicable in the terms and conditions stated below.

**A. COMMENCEMENT DATE**

The warranty period begins on the date the engine is delivered to a first retail purchaser.

**B. LENGTH OF COVERAGE**

John Deere Consumer Products, Inc. warrants to a first retail purchaser and each subsequent purchaser that the engine is free from defects in materials and workmanship which cause the failure of a warranted emission-related part for a period of two (2) years after the date of delivery to the first retail purchaser.

**C. WHAT IS COVERED:****1. REPAIR OR REPLACEMENT PARTS**

Repairs and replacement of any warranted part will be performed at no charge to you by an authorized dealer, distributor or a warranty station. You may contact the John Deere Consumer Products, Inc. customer service department at 1-704-588-3200 to get the nearest appropriate location where your warranty repairs are performed.

**2. WARRANTY PERIOD**

This warranty continues for a period of two (2) years and shall apply only to the repair, replacement or adjustment of the component parts which are not scheduled for replacement as required maintenance. Further, component parts which are scheduled only for regular inspection to the effect of 'repair or replace as necessary' shall be warranted for the warranty period. Any warranted part which is scheduled for replacement as required maintenance shall be warranted for the period of time up to the first scheduled replacement point for that part.

**3. DIAGNOSIS**

You shall not be charged for diagnostic labor which leads to the determination that a warranted part is defective, if the diagnostic work is performed at an authorized dealer, distributor or warranty station.

**4. DAMAGES**

If a warranted part failed causing damage to other engine components, consult a warranty station.

**EMISSION CONTROL SYSTEM WARRANTY STATEMENT****D. WHAT IS NOT COVERED**

1. This limited warranty does not cover any part which malfunctions, fails or is damaged due to failure to follow the maintenance and operating instructions set forth in the 1998 and later Owner's Manual including:

- (1) improper or inadequate maintenance of any warranted parts
- (2) improper installation, adjustment or repair of the engine or of any warranted part unless performed by an authorized dealer
- (3) failure to follow recommendations on fuel use contained in the 1998 and later Owner's Manual
- (4) repairs performed outside of the authorized warranty service facilities
- (5) use of parts which are not authorized by JDCP

2. Add-on or modified parts

This warranty does not cover any part which malfunctions, fails or is damaged due to alterations by changing, adding to or removing parts from the engine.

3. Expenses incurred by processing warranty claims

JDCP, any authorized dealer, distributors and warranty station shall not be liable for any loss of use of the engine, for any alternative usage, for any damage to goods, loss of time or inconvenience.

**E. HOW TO FILE A CLAIM**

All repairs qualifying under this Limited Warranty must be performed by a dealer who sold you the engine or distributors or warranty stations authorized by JDCP. In the event that any emission-related part is found to be defective during the warranty period, you shall notify John Deere Consumer Products, Inc. customer service department at 1-704-588-3200. and you will be given the appropriate warranty service facilities where the warranty repair is performed.

**F. WHERE TO GET WARRANTY SERVICE**

It is recommended that warranty service be performed by the authorized dealer who sold you the engine, although warranty service Will be performed by any authorized dealers, distributors and warranty stations anywhere in the United States. When warranty repair is needed, the engine must be brought to an authorized dealer, distributorship or warranty station's place of business during normal business hours. In all cases, a reasonable time, not to exceed 30 days, must be allowed for the warranty repair to be completed after the engine is received by the authorized dealer, distributor or service station.

**G. MAINTENANCE, REPLACEMENT AND REPAIR OF EMISSION-RELATED PARTS**

Only warranted engine replacement parts approved by JDCP should be used in the performance of any warranty maintenance or repairs on emission-related parts. If other than authorized parts are used for maintenance, replacement or repair of components affecting emission control, you should assure yourself that such parts are warranted by their manufacturer to be equivalent to authorized parts in performance and durability. JDCP however, assumes no liability under this warranty with respect to parts other than authorized parts. The use of non-authorized replacement parts does not invalidate the warranty on other components unless the nonauthorized parts cause damage to warranted parts.

**H. PARTS COVERED UNDER THE CALIFORNIA EMISSIONS WARRANTY**

- 1) Fuel Metering system
  - (i) Carburetor and internal parts
  - (ii) Air cleaner plate including choke system
  - (iii) Air cleaner case
  - (iv) Air cleaner element
  - (v) Fuel filter
- 2) Ignition System
  - (i) Spark plug
  - (ii) Flywheel magneto
  - (iii) Ignition coil
- 3) Miscellaneous Items Used in Above Systems
  - (i) Fuel hoses and sealing gaskets

**EMISSION CONTROL SYSTEM WARRANTY STATEMENT**

It is your responsibility to have all scheduled inspection and maintenance services performed at the times recommended in the 1998 and later Owner's Manual and to retain proof that inspection and maintenance services are performed at the times when recommended. JDCP will not deny a warranty claim solely because you have no record of maintenance ; however, JDCP may deny a warranty claim if your failure to perform required maintenance resulted in the failure of warranted part. The proof which you maintain should be given to each subsequent owner of the engine. You are responsible for performing the scheduled maintenance described below based on the procedures specified in the 1998 and later Owners Manual. The scheduled maintenance below is based on the normal engine operating schedule.

<b>PROCEDURE</b>	<b>INTERVAL</b>
1) Check bolts & nuts, tighten if needed	: Every 8 hours (daily)
2) Check clogging of cooling air passage and cylinder fins. Remove and clean if needed	: Every 8 hours (daily)
3) Check spark plug. Clean and adjust if needed	: Every 8 hours (daily)
4) Clean air cleaner	: Every 8 hours (daily)
5) Check muffler exhaust port, clean if needed	: Every 50 hours (Monthly)
6) Check fuel filter, replace if needed	: Every 50 hours (Monthly)
7) Replace fuel lines	: Every 200 hours (Yearly)
8) Overhaul engine	: Every 200 hours (Yearly)
9) Replace seals and gaskets	: When reassembling engine