

Green Machine®

OWNER'S MANUAL

MODEL 2840 UT26031

Expand-It® String Trimmer/Brushcutter

SERIAL NO.

IMPORTANT NOTE: USE THE ABOVE BOX TO FILL IN YOUR MODEL'S SERIAL NUMBER FOR YOUR RECORDS.

ASSEMBLY AND OPERATING INSTRUCTIONS

GREEN MACHINE® - LIMITED WARRANTY

The manufacturer warrants to the original retail purchaser that this Product is free from defects in material and workmanship and agrees to repair or replace, at Manufacturer's discretion, any defective product free of charge within these time periods from the date of purchase:

- **Two years, if the Product is used for personal, family, or household use;**
- **One year, if the Product is used for commercial or any other use.**

This warranty is not transferable and does not cover damage resulting from defects other than in material or workmanship, or damage caused by unreasonable use, including the failure to provide reasonable and necessary maintenance. Also, the warranty obligations do not apply to conditions resulting from misuse, alteration or accident. In addition, this warranty does not cover general check-ups on electrical equipment, tune-ups on gasoline engines, or replacement of non-defective parts (such as electrical brushes, cables, plugs, spark plug, filters, starter ropes, etc.) that may wear and need to be replaced with reasonable use within the warranty period or which may require replacement in connection with normal maintenance. This warranty applies only to products sold within the United States of America, the District of Columbia, Canada, Mexico, the Commonwealth of Puerto Rico, the Virgin Islands, Guam, the Canal Zone, or American Samoa.

SAVE YOUR SALES SLIP

Proof of purchase in the form of your dated sales receipt, cash register slip, etc. showing the serial number and the model of your Product will be required before our dealers can perform warranty service on the Product. You must at your own expense, arrange to deliver or ship the Product for warranty repairs and arrange for pickup or return of the Product after repairs have been made.

This warranty does not apply to any trade accessory, engine, or electric motor which is separately warranted by another manufacturer and not manufactured by the manufacturer.

THIS LIMITED WARRANTY IS IN LIEU OF ALL OTHER EXPRESS WARRANTIES. ANY IMPLIED WARRANTY OF FITNESS FOR A PARTICULAR PURPOSE, MERCHANTABILITY OR OTHERWISE, APPLICABLE TO THIS PRODUCT, SHALL BE LIMITED IN DURATION TO THE DURATION OF THIS LIMITED WARRANTY. THE MANUFACTURER SHALL NOT BE LIABLE FOR ANY SPECIAL, INCIDENTAL OR CONSEQUENTIAL DAMAGES.

SOME STATES DO NOT ALLOW LIMITATIONS ON HOW LONG AN IMPLIED WARRANTY LASTS, SO THE ABOVE LIMITATION MAY NOT APPLY TO YOU. ALSO, SOME STATES DO NOT ALLOW THE EXCLUSION OR LIMITATION OF INCIDENTAL OR CONSEQUENTIAL DAMAGES, SO THE ABOVE LIMITATION OR EXCLUSION MAY NOT APPLY TO YOU.

HOW TO OBTAIN WARRANTY SERVICE

Warranty service can be obtained from a Green Machine® dealer authorized to make warranty repairs. If you need warranty service, check first with the dealer from whom you purchased the Product. **FOR WARRANTY SERVICE INFORMATION OUTSIDE THE USA AND CANADA, PLEASE CONTACT YOUR LOCAL GREEN MACHINE® DEALER.**

The manufacturer will not make any reimbursements for warranty service, except to Green Machine® dealers authorized to make warranty repairs. You must present your sales receipt when making any claim for warranty service.

This warranty gives you specific legal rights, and you may also have other rights which vary from state to state.

This warranty is given by Homelite, Inc. Post Office Box 7047, Charlotte, North Carolina 28241.

Green Machine®
by **John Deere**

P.O. Box 7047
14401 Carowinds Blvd.
Charlotte, N.C. 28241

P/N 19697

We are pleased that you have chosen a Green Machine® product to assist you with your work. Your Green Machine® product was assembled using the latest manufacturing methods and materials to bring you a product of the highest quality.

This Owner's Manual is provided to aid you in the proper assembly and the safe, reliable operation of your new Green Machine® product. Read it and become thoroughly familiar with the proper operating procedures before you first use this product. Make sure anyone who operates your Green Machine® product is fully acquainted with the proper operating procedures. Careful assembly, safe operation and proper maintenance in accordance with this Owner's Manual will provide you with maximum performance and product life.

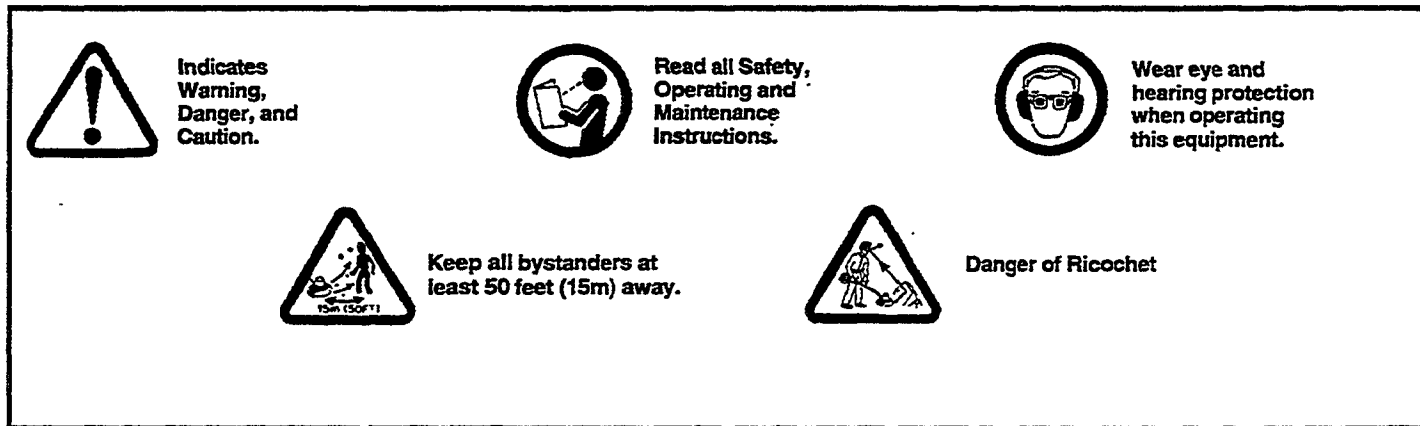

Warning: READ THE OWNER'S MANUAL BEFORE USING YOUR CHAIN SAW. FOLLOW ALL INSTRUCTIONS FOR SAFE OPERATION.

SAFETY INSTRUCTIONS

SAVE THESE INSTRUCTIONS

OPERATION

- Use this unit for cutting recommended material only. Do not use for any other purpose.
- Never start or run the engine inside a closed area, breathing exhaust fumes can kill.
- **CLEAR THE WORK AREA BEFORE EACH USE. REMOVE ALL OBJECTS SUCH AS ROCKS, BROKEN GLASS, NAILS, WIRE, OR STRING WHICH CAN BE THROWN OR BECOME ENTANGLED IN THE BLADE.**
- Be sure the blade is properly installed and securely fastened. Failure to use the proper parts can cause the cutting attachment to fly off and seriously injure the operator and/or bystanders.
- Exposure to vibrations through prolonged use of gasoline powered hand tools could cause blood vessel or nerve damage in the fingers, hands, and wrists of people prone to circulation disorders, or abnormal swellings. Prolonged use in cold weather has been linked to blood vessel damage in otherwise healthy people. If symptoms occur such as numbness, pain, loss of strength, change in skin color or texture, or loss of feeling in the fingers, hands, or wrists, discontinue the use of this tool and seek medical attention.
- **FOLLOW THESE INSTRUCTIONS TO REDUCE THE RISK OF INJURY:**
 - **WEAR FULL EYE AND HEARING PROTECTION WHILE OPERATING THIS EDGER.**
 - Wear heavy long pants, shoes and gloves.
 - Keep all bystanders, children and pets at least 50 feet away.
 - Do not wear loose clothing or jewelry.
 - Secure long hair so it is above the shoulder.
 - Do not operate this edger when you are tired, ill or under the influence of alcohol, drugs or medication.
 - Do not operate in poor lighting.
 - Keep firm footing and balance. Do not overreach.
 - Keep all parts of your body away from the string head and hot surfaces.
 - Keep cutting attachment below waist level.
- **ALWAYS STOP ENGINE AND REMOVE SPARK PLUG WIRE BEFORE MAKING ANY ADJUSTMENTS OR REPAIRS EXCEPT CARBURETOR ADJUSTMENTS.**

MAINTENANCE

- Use only **GREEN MACHINE®** replacement parts. Failure to do so may cause poor performance and possible injury.
- Inspect unit before each use for loose fasteners, fuel leaks, etc. Replace damaged parts. Replace edger blade if cracked, chipped, or damaged in any way. Be sure the stringhead is properly installed and securely fastened. Failure to do so can cause serious injury.
- Make sure all deflectors and handles are properly and securely attached.
- Use only monofilament string in the stringhead.

For Green Machine Parts Call 606-678-9623 or 606-561-4983

- The cutting head will spin during carburetor adjustments. Wear protective equipment and observe all safety instructions.
- Before storing, allow the engine to cool.
- Empty the fuel tank and restrain the unit from moving before transporting in a vehicle.

REFUELING (DO NOT SMOKE!)

- Mix and store fuel in a container approved for gasoline.
- Mix fuel outdoors where there are no sparks or flames.
- Select bare ground, stop engine, and allow to cool before refueling.
- Loosen fuel cap slowly to release pressure and to keep fuel from escaping around the cap.
- Wipe spilled fuel from the unit. Move 10 feet away from refueling site before starting engine.

BLADE SAFETY

- Before each use, check to be sure that blade is firmly attached. Be sure throttle return to the neutral position when released and that the blade does not rotate at idle.
- A coasting blade can injure while it continues to spin after the engine is stopped or throttle trigger is released. Hold the coasting blade in heavy grass or brush until it stops.
- The front handle must be mounted properly. The front handle will assist in keeping the cutting attachment away from the operator.
- **Exercise extreme caution when using the blade with this unit. BLADE THRUST is the reaction that may occur when the spinning blade contacts anything it cannot cut. This contact may cause the blade to stop for an instant, and suddenly “thrust” the unit away from the object that was hit. This reaction can be violent enough to cause the operator to lose control of the unit. Blade Thrust can occur without warning if the blade snags, stalls, or binds. This is more likely to occur in areas where it is difficult to see the material being cut.**

In order to control the unit when Blade Thrust occurs:

- Main a good comfortable stance and balanced position.
- Always hold the handles firmly with both hands.
- Approach material to be cut from left to right so that the unit will be pulled towards the cut instead of pushed toward the operator.
- Always cut at full throttle. Blade has maximum cutting power and is less likely to stall or bind.
- Keep hands, feet, and unit in proper position.
- Cut only material recommended. Avoid letting blade contact material it can not cut, such as stumps, rocks, emtal, etc.

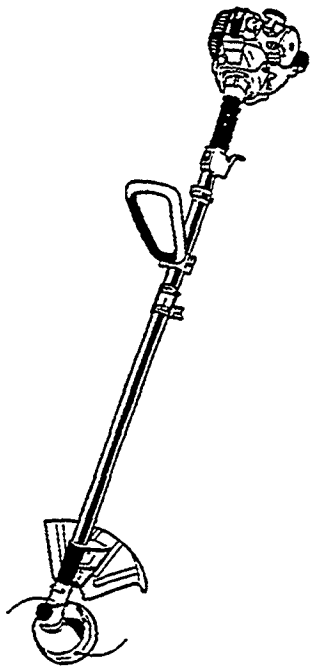
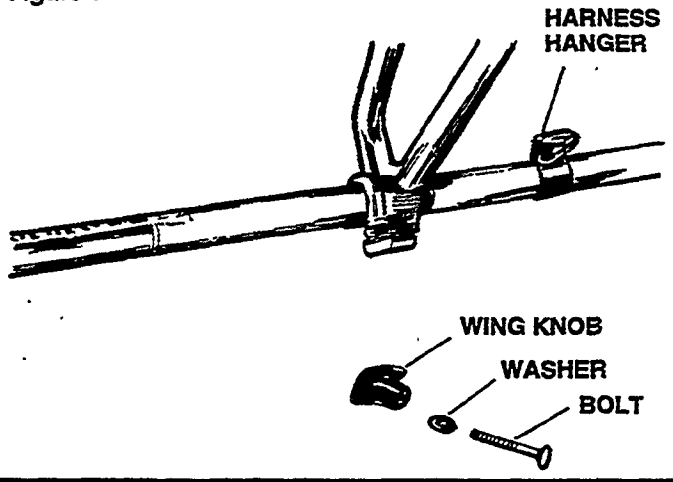

Figure 1



2840 STRINGTRIMMER/BRUSHCUTTER EXPAND-IT® SYSTEM

Model 2840 Expand-It® Stringtrimmer/brushcutter with a long 47.8" shaft for operator reach and comfort. This unit accepts optional brush and saw blades, and interchangeable with 4 other yard care tools.

1. ASSEMBLY

- Snap the mid-handle over shaft tube adjacent to the tube coupler (top of handle should angle back toward engine).
- Install the bolt, washer, and knob (Figure 1).
- Position the handle approximately 1 - 1 1/2 inches above coupler and tighten wing knob.
- **Note:** Handle may be repositioned for best balance and comfort after lower unit is attached.

Figure 2

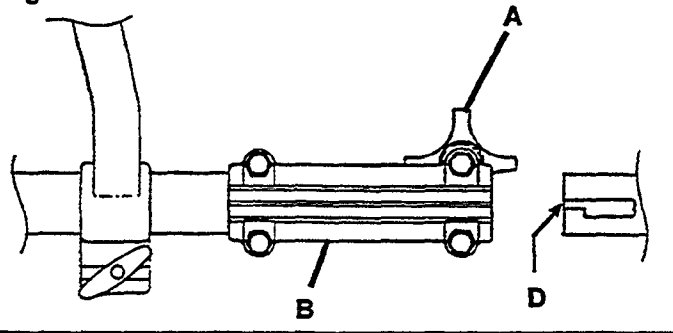
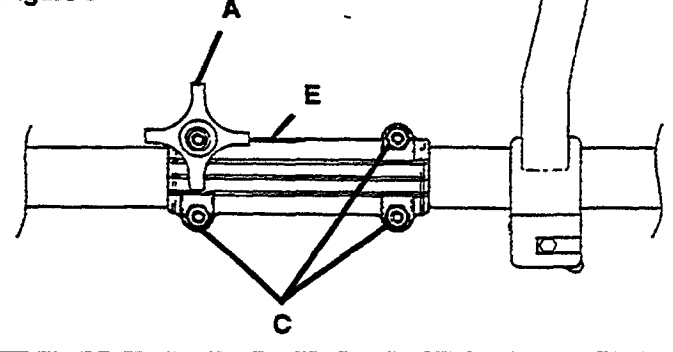

Figure 3



ATTACHING LOWER UNIT

The lower units connect to the power unit by means of the driveshaft coupler device attached to the power unit driveshaft tube.

1. First, loosen the knob (A) near the open end of the coupler (B). It is not necessary to loosen the other three (3) screws (C).
2. Position the slot (D) of the lower tubes as shown in Figure 2 and slide the lower unit into the coupler until the tubes of the power unit and lower unit solidly meet inside the coupler. Rotate lower tube to lock in place. By looking in the slot (E) (Figure 3) on the top, see that both tube ends are abutted together before re-tightening the knob. The inner driveshafts will align themselves.
3. For changing lower units or breaking down for storage, follow the sequence in reverse.



CAUTION: Be certain the knob is fully tightened before operating equipment, and it should be periodically checked for tightness during use.

3. ASSEMBLY

- Using the tools shown in **Figure 4**, remove the bolt (left hand thread), star washer, and flat washer at the bottom of the gearcase.

Note: Save bolt washers as they are needed when using brush or saw blades.

- While holding the lower flange washer with the large spanner wrench, thread the rotary head onto gearcase as shown in **Figure 5**. Tighten the rotary head as tight as possible by hand.
- To install brush or saw blades (**Figure 6**):
Remove bolt (LH), star washer and small flat washer at the bottom of the gear case (**Figure 7**).
- Remove lower flange washer and place blade on upper flange washer making sure that arbor hole in blade is centered on the arbor embossment on upper flange washer.
- Install lower flange washer making sure that the splines line up and flange washer is completely seated.
- Re-install small flat washer, star washer, and bolt (Note: Bolt is left hand thread) and is turned counterclockwise to tighten (**Figure 7**).
- Special Note**
Take special care when installing blades, as the cutting edge and/or points of the blade are very sharp. Make sure tools used are properly seated on their respective bolt or flange washer, and you have a firm grip on the tools.
- The blade rotation is clockwise (when viewing from below) so cutting edge of blades must face in that direction.

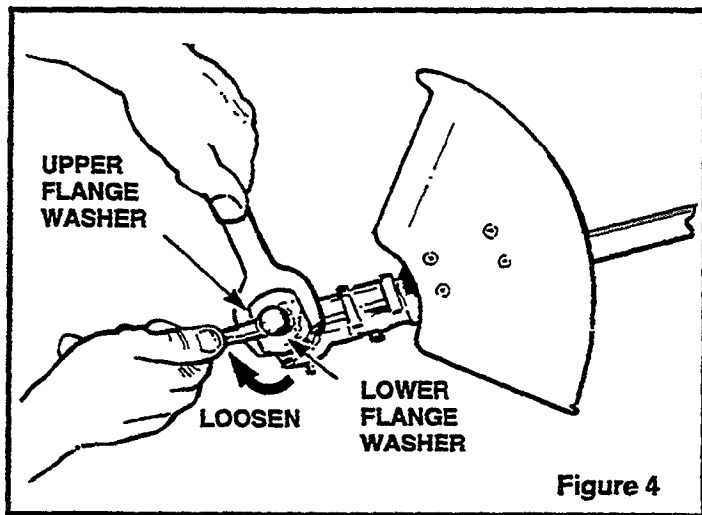

Figure 4

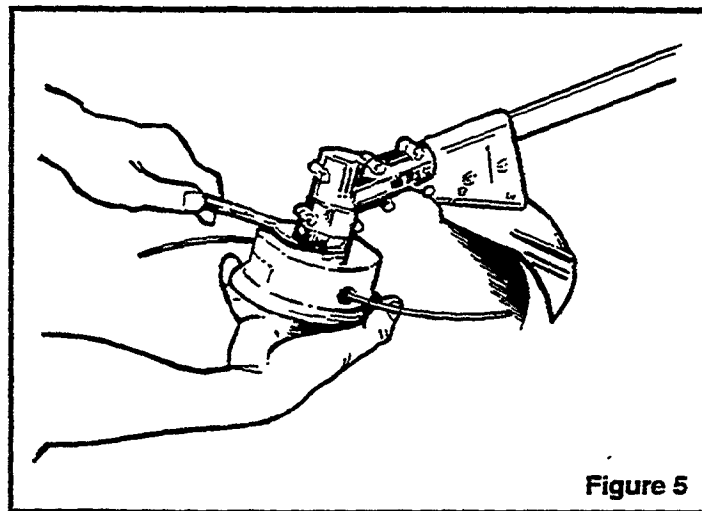

Figure 5

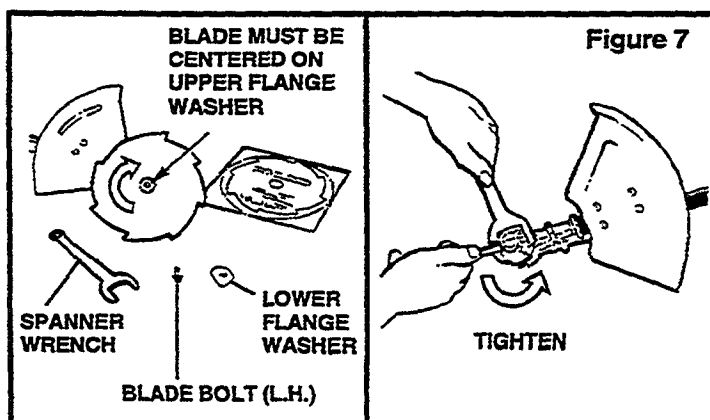
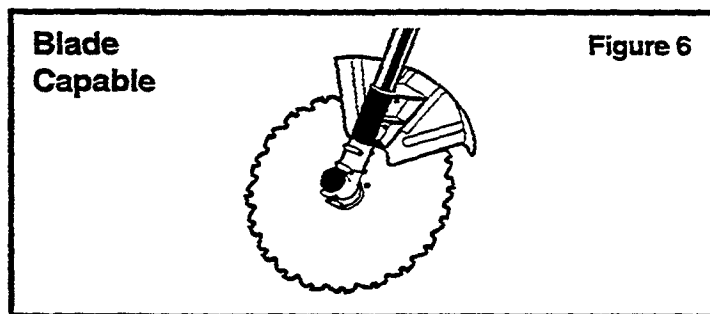

Figure 7



CAUTION: Never operate without blade guard/head shield in place; keep bystanders at least 50 ft. away.

4. SUPPLYING FUEL:

- Fill the fuel tank with fuel to 7/8 full, using a mixed fuel of gasoline and 2 cycle air cooled engine oil.

REFUELING (DO NOT SMOKE!)

- Mix and store fuel in a container approved for gasoline.
 - Mix fuel outdoors where there are no sparks or flames.
 - Select bare ground, stop engine, and allow to cool before refueling.
 - Loosen fuel cap slowly to release pressure and to keep fuel from escaping around the cap.
 - Wipe spilled fuel from the unit. Move 10 feet away from refueling site before starting engine.
 - **Special Note: Never use gasohol. If gasohol is used, engine warranty will be voided. To test for alcohol content in gasoline, an inexpensive gasohol tester is available, order part # GM 27339.**
 - **RECOMMENDED FUEL: THIS ENGINE IS CERTIFIED TO OPERATE ON UNLEADED GASOLINE INTENDED FOR AUTOMOTIVE USE.** Mix Green Machine 32:1 or Green Machine Premium Exact Mix oil with gasoline according to the instructions on the package. If Green Machine oil is not available, use a high quality 2-cycle engine oil mixed at 4 oz. per gallon. **DO NOT USE AUTOMOTIVE OIL OR 2-CYCLE OUT-BOARD OIL.**
- Thoroughly mix the gasoline and 2-cycle oil before pouring the fuel mix into the engine's fuel tank.

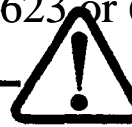

WARNING:

1. Never smoke when refueling or refuel in an area with open flame (such as water heater pilot light). Gasoline vapors spread rapidly and are highly explosive.
2. Always stop engine and wait for it to cool before refueling.
3. Clean up any spills and dispose of clean-up materials.
4. After refueling, move to another area for starting.
5. Never over fill. Fill tank only 7/8 full to avoid spillage.



WARNING

The fuel tank may be under pressure. Remove the cap slowly to avoid spurting of fuel.

5. INSPECTION

- Always inspect all fasteners for tightness and/or missing parts. Tighten or replace before use.
- Read and understand all safety and operating instructions before use.
- Check for any fuel leaks. If any, correct before use.
- Make sure all air passages are free of dirt, dust, or any other foreign material.
- Inspect air cleaner for cleanliness.

6. STARTING THE ENGINE, WHEN COLD (INITIAL ENGINE STARTING)

- Slide stop switch (on top of trigger) to run position (towards engine).
- Push the primer pump until fuel flows through the clear plastic return line (Figure 8).
- Place choke lever in the closed position (Figure 8).
- Lock throttle lever in the start position as shown in (Figure 9).
- Pull starter rope slowly, until engine compression is felt (Figure 9). Pull the starter in short rapid strokes until engine starts.
- Avoid pulling the rope to its full extension as starter failure could result.
- Once the engine has started, slowly return the choke lever to its open position.

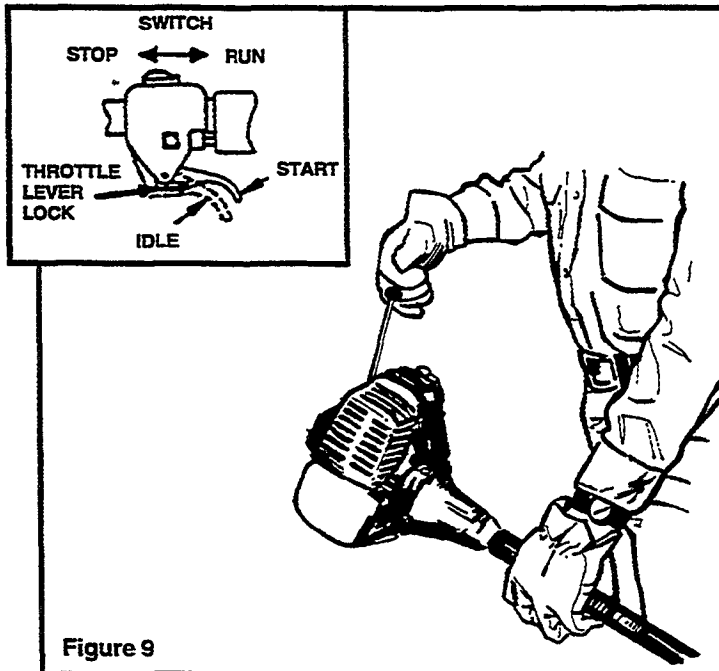
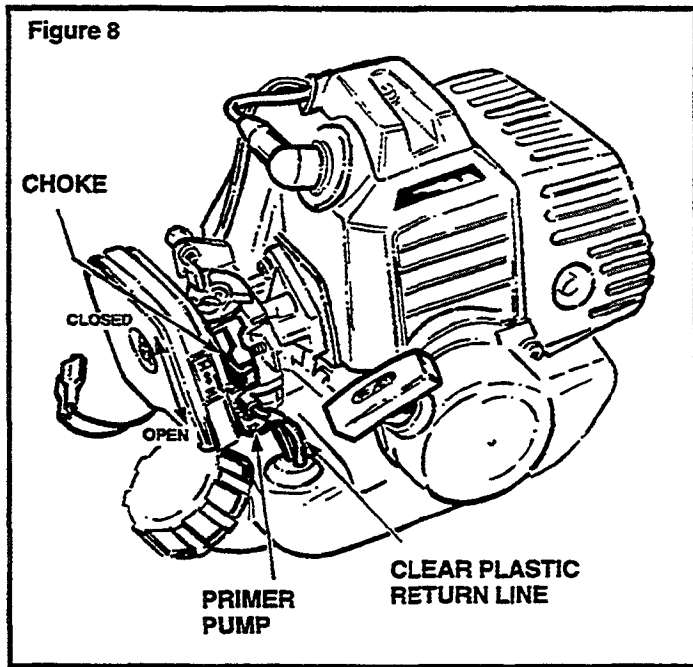

Figure 9

- Return the throttle lever to its idle position.
- Always allow the engine to run 1 to 2 minutes at idle for warm up before starting work.
- **Special Note:**
Place the unit on the ground when starting. Do not use your foot, or knee to hold it down while pulling up on the rope (Figure 10). This will cause the tube and cable to become bent and then break. Never allow the starter rope to snap back.

WHEN WARM (RESTARTING ENGINE)

- Hold throttle lever in the open position.
- Place choke lever in its open position.
- Pull starter rope as outlined in "Starting When Cold".
- **Note:** If engine fails to start, push primer until fuel appears in clear plastic return line.

7. STOPPING ENGINE

- Return throttle lever to its idle position, and allow the engine to idle for a short period (approximately 30 seconds). This allows the engine to cool down.
- Push stop switch to "Stop" position (toward the cutting head). Be sure to return the stop switch to the run position before trying to start unit.
- **Note:** Except for emergencies, avoid stopping engine while it is running at high speed, this avoids overheating the engine.

8. ADJUSTING

- Your Green Machine® engine has been adjusted at the factory for optimum performance and fuel consumption, and no further adjustment should be required. However, because of varying atmospheric and climatic conditions, some minor adjustment may be needed for your area.
- Adjusting idle speed should always be done with a tachometer to insure proper idle speed (2,800 to 3,300 rpm). If a tachometer is not available, the idle speed may be adjusted as follows (Figure 11).
 1. Turn idle speed screw clockwise until cutting head or lower drive begins to move.
 2. Turn idle speed screw counterclockwise until lower drive stops.
 3. Turn idle speed screw approximately 1/4 to 3/4" turn further counterclockwise.
- If the engine does not idle properly after this adjustment, contact your nearest Green Machine® dealer for service.
- Condition of the air cleaner is very important to the operation and life of the engine, and also has a major affect on carburetor adjustments. The air cleaner should be checked for cleanliness before each use, and before making any carburetor adjustments.

Figure 10

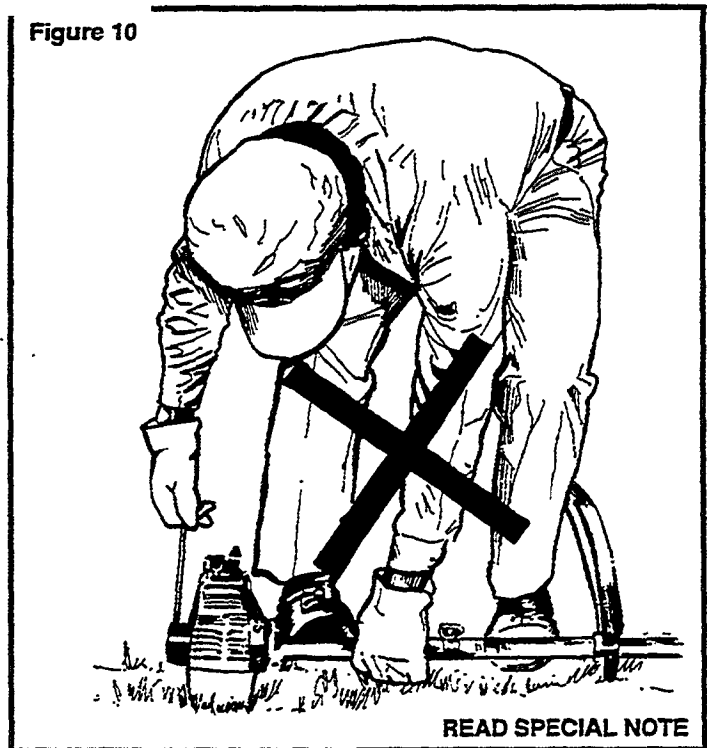
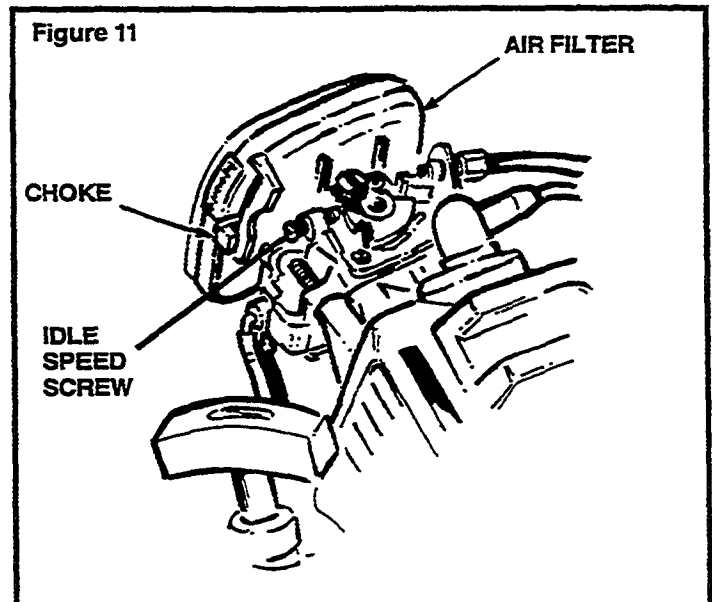

Figure 11



12. MAINTENANCE For Green Machine Parts

Daily

- Carefully inspect complete unit for damaged, loose or missing parts. Correct before use.
- Carefully inspect for any fuel leaks. Correct immediately.
- Check air cleaner for cleanliness.
- Remove all dust, dirt, and grass from the entire unit after each use.

30-Hour Service, or Once a Week for Commercial Use.

- All items under daily service plus:
- Remove, clean, and regap spark plug (0.7mm/0.025 inches) (Figure 12).
- Clean and service air filter (after cleaning, put small amount of engine oil on sponge and squeeze out excess) (Figure 13).
- Check fuel filter in tank and clean if needed. (Figure 13).
- Remove cylinder cover and clean ut all dust, dirt, and foreign material.

Figure 12

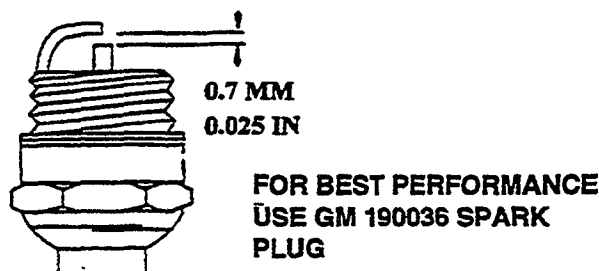

SAFETY

- Before each use always inspect your Green Machine® for loose, missing, damaged or broken parts. Correct before using.
- Always wear approved eye protection (safety goggles).
- Due to the danger of thrown objects and the danger of striking others with the string or blade, keep bystanders and pets away from the work area at all times.
- Do not wear loose fitting clothes while operating unit.
- Never operate unit while barefoot or wearing sandals.
- Never operate unit without shields or guards in place and in good working order.
- Use only genuine Green Machine® blades and rotary heads.
- Never use any type of wire in place of the nylon string.
- Never touch engine or muffler during operation, or immediately after shutdown.
- Never touch spark plug, ignition plug cap, or high tension wire while engine is running.
- Always make sure engine is securely mounted to driveshaft before each use.
- Always check for any fuel leaks before each use and correct before use.
- Never operate unit indoors or in an enclosed area.
- Your Green Machine product is not a toy. Do not allow children to play with it or use it.

Figure 13

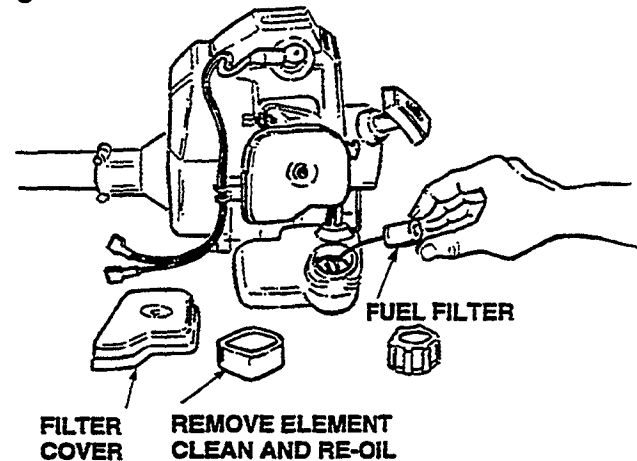
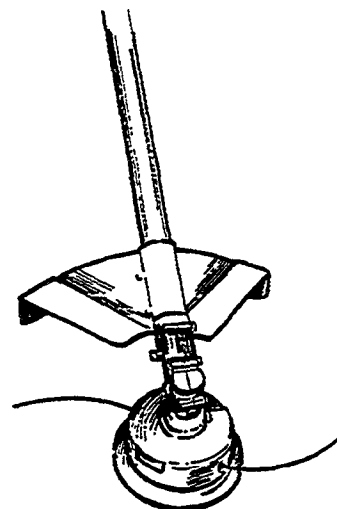

Figure 14





WARNING:

Blade use

- Extreme care must be taken when using brush or saw blades to insure safe operation.
- When the blades hit a hard object a serious sideward reaction could occur (See explanation of "BLADE THRUST" on page 3).
- Never attempt blade work without first inspecting and clearing the area of unseen objects such as concrete, fencing, wire, wood, metal, etc.
- Never use blades near sidewalks, fencing, posts, buildings or other immovable objects.
- Use the brush and saw blades only for that cutting which is recommended. Brush blade-cuts up to 3/8 inch diameter.
- Never use a blade after hitting a hard object without first inspecting it for bent cutters and cracks. Do not use if either condition is found.
- Use only Green Machine® saw blade No. 92130 or No. 92140. Do not use crosscut blade.
- Always use shoulder harness whenever blades are used, No. 400175.
- Have a professional re-sharpen your blade or saw.

CUTTING TECHNIQUE:

Hold the unit so that the rotary head is at an approximately 30° angle to the ground (Figure 15).

- Allow the very tip of the line to do the cutting.
- Always operate the unit with the correct line size (.080 dia.).
- Always use the correct line length (maximum 6.0, minimum 3.0 inches).
- **Note:** As the cutting line wears down, engine speed (RPM) will increase. Allowing the engine to run at high RPM (3 inch cutting or less) for a prolonged period will shorten engine life.
- Cut from left to right with the engine at full throttle, so that clippings will be thrown away from you (Figure 16).

2. EXTENDING LINE:

- As you perform your trimming tasks, the cutting line will wear shorter. It may be extended automatically with the engine running, or manually, with the engine stopped.
- **Engine running:** (At full speed) lightly tap (do not pound) the rotary head on the ground. Line will advance approximately 1/2 inch per tap.
- When tapping for line, it should be done on bare ground or a hard surface.

Note: The cutting line will not extend automatically if the line is worn too short. You should extend the line before it is worn to 3 inch length.

Figure 15

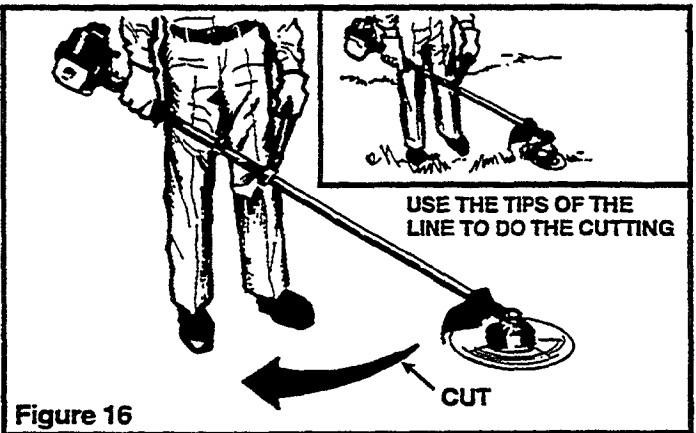
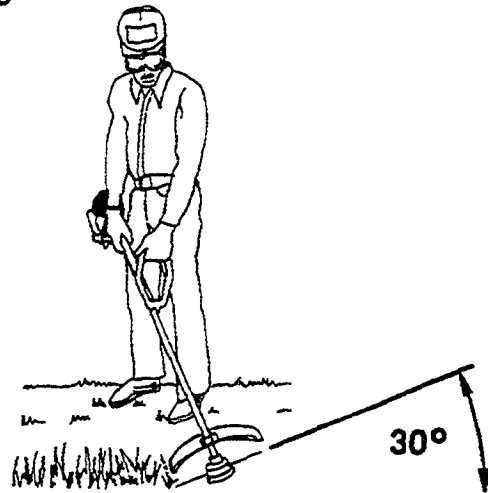

Figure 16

Figure 17

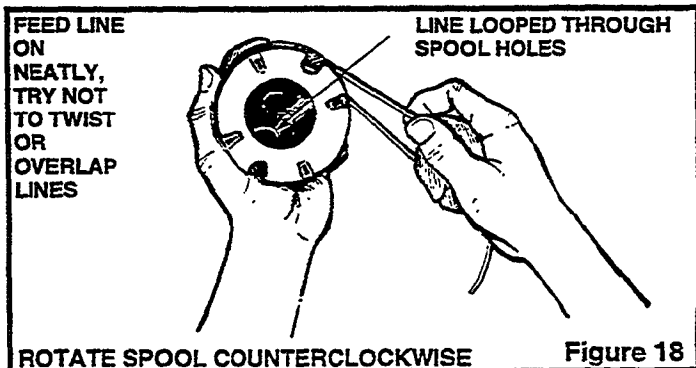
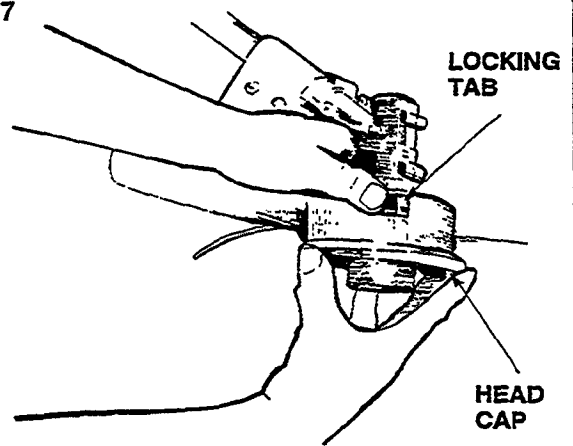
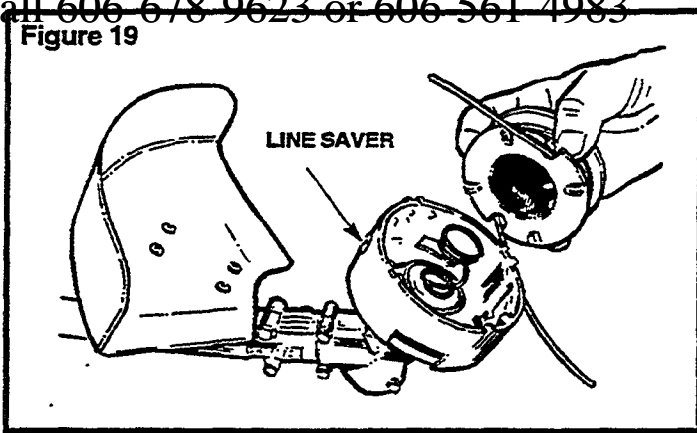

Figure 18

- **Engine Stopped:** The line can be advanced manually by turning the unit over so that you are facing the bottom of the rotary head. While pulling outward on one of the cutting lines, push in on the spool. When the line stops, release the spool and continue pulling the line. Keep repeating this procedure until the desired amount of line is extended.
- **Note:** Never operate the trimmer with more than six (6) inches of line extended outside the rotary head. Excessive line length can often be identified by low engine RPM when the throttle lever is in the full throttle position.



3. TO REPLENISH LINE SUPPLY:

- Push in one of the locking tabs, releasing it from its notch (Figure 17,18), and pull on the rotary head cap.
- Once both locking tabs have released, lift rotary head cap off and remove spool.
- Cut a length of cutting line that is .080 diameter and approximately 30 ft. long.
- Loop line through holes in spool and make certain that both lines are even (Figure 18).
- Hold spool as shown (Figure 18) and feed line on neatly by rotating the spool counterclockwise.
- **Note:** Do not wind line on, rotate the spool
- **Note:** Clean all dirt, dust, and grass out of rotary head, spool, and head cap before reassembling.
- Once the line is on the spool, hold spool as shown (Figure 19) and insert lines in their respective line-savers and place spool back into the rotary head.
- **Note:** Be certain that the lines do not become trapped under the spool (Figure 20).
- Re-install rotary head cap by aligning locking tabs with their notches and pushing cap down until both locking tabs are securely locked (Figure 20).
- Before operating the unit, check by advancing the line manually, making sure lines are not trapped, and rotary head is assembled correctly.

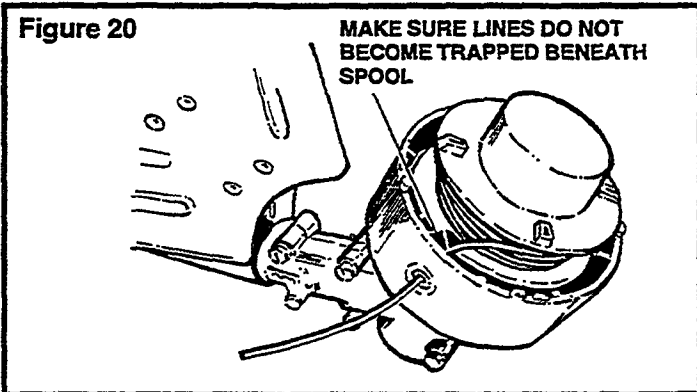

4. MAINTENANCE

- Each 10 hours of use, the gearcase should be re-greased by first removing the cutting head (or blade), flange washers and upper flange spacer (Figure 22).
- Add grease until it appears between the spline and bearing.
- The flex cable is lubricated during assembly at the factory and needs no scheduled maintenance. However if it is removed, re-grease and install exactly as it was removed. **Do not reverse the flex cable. Use grade no. 2 grease.** (High-Low Temperature, Multi-Purpose - Part #18453).

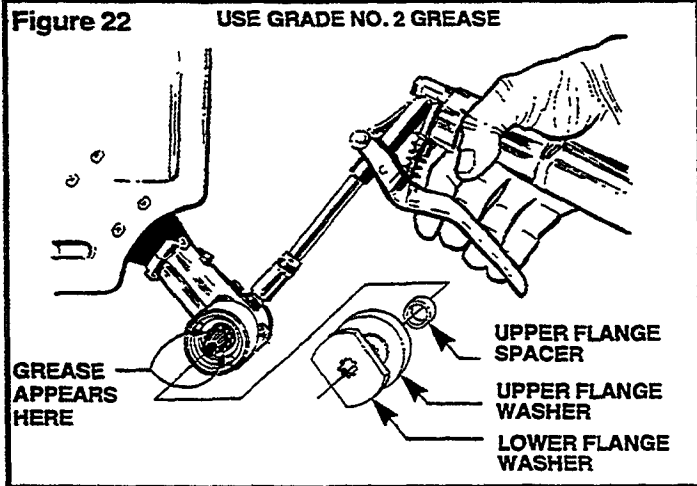
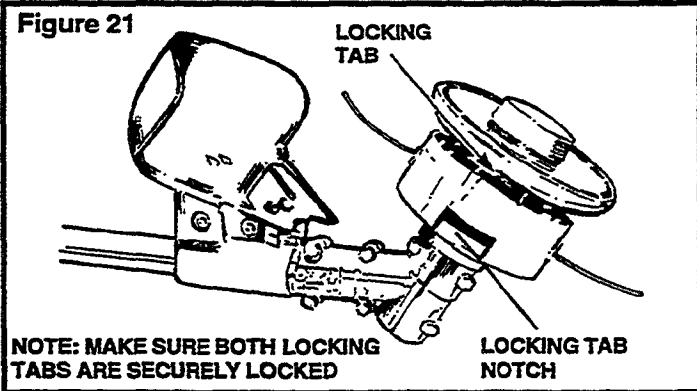

**GREEN MACHINE™
TROUBLE SHOOTING CHART**

FAILURE OF ENGINE TO START - NO SPARK 1. Failure located on the spark plug side	1. The electrode of spark plug is wet 2. Carbon deposit sticks to the electrodes of spark plug 3. Poor insulation caused by crack, etc. of insulator 4. Undersize or oversize gap of the electrodes of spark plug 5. Burning of the electrodes of spark plug	1. Dry it 2. Clean it 3. Replace spark plug 4. Adjust the gap to 0.6mm 5. Replace spark plug
2. Failure located on the magneto side	1. Coil burnout 2. Coil poor insulation 3. Cord coating breakage 4. Unit burnout	1. Replace coil 2. Replace coil 3. Replace or repair cord 4. Replace magneto
HAS SPARK 1. Proper compression and sufficient fuel	1. Engine flooded 2. Use of improper fuel mixture	1. Remove spark plug and discharge outward with recoil starter 2. Replace with proper fuel 32:1 mix
2. Sufficient supply of fuel but compression is poor	1. Heavy wear of cylinder, piston and piston ring 2. Loose spark plug	1. Replace all worn parts 2. Tighten
3. No supply of fuel to the carburetor	1. Fuel tank is empty 2. Loose fuel hose fitting or loose carburetor 3. Filter clogging 4. Fuel is available in the tank,, however, fuel does not reach the carburetor 5. Air vent in the fuel tank clogging	1. Refill the fuel tank 2. Tighten fuel lines or carburetor 3. Clean or replace filter 4. Refer to the starting procedure 5. Clean it
POWER IS NOT SUFFICIENT 1. Compression of engine is normal and there is no mis-firing	1. Air cleaner clogging 2. The muffler is plugged with carbon 3. Air leakage through the pipe fitting, etc. 4. Fuel passage clogging 5. Water is mixed in fuel	1. Clean 2. Clean the muffler or replace 3. Tighten the fitting securely 4. Clean 5. Replace with proper fuel
2. Overheating is observed	1. Excessive lean fuel mixture 2. Use of improper mixed oil 3. Carbon deposit 4. Fan cover, cylinder fin, etc. are stuffed with dirt 5. Forced operation	1. Adjust and clean carburetor 2. Replace with 2-cycle 32:1 mix 3. Clean 4. Clean and remove dirt 5. Operate properly
3. Knocking noise is heard	1. Cylinder overheat 2. Use of improper fuel 3. The combustion is covered with carbon deposits	1. Adjust carburetor, clean cylinder fin 2. Replace with proper fuel: 25:1 mix 3. Clean the combustion chamber
4. Air Suction	1. Loose carburetor 2. Loose fuel pipe	1. Tighten 2. Insert firmly
ENGINE RUNS BUT TOOL WILL NOT PERFORM	1. Lower tool nut fully engaged in coupler	1. Refer to owner's manual for proper assembly or see authorized service dealer for assistance
ENGINE STOPS WHILE IN OPERATION 1. Engine stops abruptly	1. Defective stop button 2. Dislocation of plug cap 3. The piston shows score surface with indication of seizure 4. Short circuit of spark plug electrode due to carbon deposit 5. Failure of proper functioning of magneto	1. Replace 2. Fix firmly 3. Repair or replace 4. Clean 5. Disassemble and replace necessary parts
2. Engine stops gradually	1. Empty fuel tank 2. Inside carburetor clogging 3. Fuel tank clogging 4. Water is mixed in fuel	1. Refill 2. Disassemble and clean 3. Disassemble and clean breather 4. Replace with proper fuel
ENGINE WILL NOT STOP WHEN TURNED OFF	1. The extreme end portion of spark plug is red-heated 2. Broken stop button	1. Clean or replace spark plug and adjust the gap to 0.6mm 2. Replace worn part
SHAFT VIBRATES	1. Cord is not in balance - both cords not of same length 2. Cord is worn out 3. Nylon cord head is bent 4. Saw or Brush blade not centered on Holder A 5. Grease or oil has gotten into clutch assembly (clutch housing) 6. Lower gear case is out of grease	1. Equalize cord length at 6 inches 2. Same as #1 3. Replace arbor post 4. Re-center blade on holders 5. Clean clutch shoes and drum 6. Grease gear case - 30 operating hours

EMISSION CONTROL SYSTEM WARRANTY STATEMENT

(Owner's Defect Warranty Rights and Obligations)

In the interest of the environment, MHI engines that meet strict emission requirements are labeled. "This ULGE engine conforms to 1995-1996 California Emission Control Regulations".

California Emission Control Defects Warranty Statement

The California Air Resources Board and MHI are pleased to explain the emission control system warranty on your 1995 utility or lawn and garden equipment engine (ULGE). In California, new utility or lawn and garden equipment engines must be designed, built and equipped to meet the state's stringent anti-smog standards. MHI must warrant the emission control system on your engine for the periods of time listed below, provided there has been no abuse, neglect or improper maintenance of your utility or lawn and garden equipment engine.

Your emission control system includes parts such as the carburetor, air cleaner, ignition system, muffler and catalytic converter. Also included may be connectors and other emission related assemblies.

Where a warrantable condition exists, MHI will repair your utility or lawn and garden equipment engine at no cost to you including diagnosis, parts and labor.

MITSUBISHI HEAVY INDUSTRIES, LTD. Emission Control Defects Warranty Coverage

The utility or lawn and garden equipment engines are warranted relative to emission control parts defects for a period of two years, subject to provisions set forth below. If any covered part on your engine is defective, the part will be repaired or replaced by MHI.

Owner's Warranty Responsibilities

As the utility or lawn and garden equipment owner, you are responsible for the performance of the required maintenance listed in your Owner's Manual. MHI recommends that you retain all your receipts covering maintenance on your utility or lawn and garden equipment engine, but MHI cannot deny warranty solely for the lack of receipts or for your failure to ensure the performance of all scheduled maintenance.

As the utility or lawn and garden equipment engine owner, you should however be aware that MHI may deny you warranty coverage if your utility or lawn and garden equipment engine or a part has failed due to abuse, neglect, improper maintenance or unproved modifications.

YOU ARE RESPONSIBLE FOR PRESENTING YOUR UTILITY OR LAWN AND GARDEN EQUIPMENT ENGINE TO AN AUTHORIZED SERVICE DEALER OR LAWN AND GARDEN EQUIPMENT MANUFACTURER TO WHOM MHI WOULD SELL ENGINES AS SOON AS A PROBLEM EXISTS. THE UNDISPUTED WARRANTY REPAIRS SHOULD BE COMPLETED IN A REASONABLE AMOUNT OF TIME, NOT TO EXCEED 30 DAYS. IF YOU HAVE ANY QUESTION REGARDING YOUR WARRANTY RIGHTS AND RESPONSIBILITIES, YOU SHOULD CONTACT GREEN MACHINE'S CUSTOMER REPRESENTATIVE AT 1-704-588-3200.

THE EMISSION WARRANTY IS A DEFECTS WARRANTY. DEFECTS ARE JUDGED ON NORMAL ENGINE PERFORMANCE. THE WARRANTY IS NOT RELATED TO AN IN-USE EMISSION TEST.

MITSUBISHI HEAVY INDUSTRIES, LTD. Emission Control Defects Warranty Provisions

The following are specific provisions relative to your Emission Control Defects Warranty Coverage. It is in addition to the MHI engine warranty for non-regulated engines found in the Owner's Manual.

1. WARRANTED PARTS

COVERAGE UNDER THIS WARRANTY EXTENDS ONLY TO THE PARTS LISTED BELOW (THE EMISSION CONTROL SYSTEMS PARTS) TO THE EXTENT THESE PARTS WERE PRESENT ON THE ENGINE PURCHASED.

FUEL METERING SYSTEMS

CARBURETOR AND INTERNAL PARTS

COLD START ENRICHMENT SYSTEM (SOFT CHOKE)

FUEL FILTER (UP UNTIL THE FIRST SCHEDULED CHANGE)

FUEL INLET HOSE

FUEL OUTLET HOSE

AIR INDUCTION SYSTEM

AIR FILTER (ELEMENT)

IGNITION SYSTEM

SPARK PLUG(S)

MAGNETO IGNITION SYSTEM

2. LENGTH OF COVERAGE

MHI WARRANTS TO THE INITIAL OWNER AND EACH SUBSEQUENT PURCHASER THAT THE WARRANTED PARTS SHALL BE FREE FROM DEFECTS IN MATERIALS AND WORKMANSHIP WHICH CAUSE THE FAILURE OF THE WARRANTED PART(S) FOR A PERIOD OF TWO YEARS FROM THE DATE THE ENGINE IS DELIVERED TO A RETAIL PURCHASER.

3. NO CHARGE

REPAIR OR REPLACEMENT OF ANY WARRANTED PART WILL BE PERFORMED AT NO CHARGE TO THE OWNER, INCLUDING DIAGNOSTIC LABOR WHICH LEADS TO THE DETERMINATION THAT A WARRANTED PART IS DEFECTIVE, IF THE DIAGNOSTIC WORK IS PERFORMED AT AN AUTHORIZED SERVICE DEALER OF LAWN AND GARDEN EQUIPMENT MANUFACTURER TO WHOM MHI WOULD SELL ENGINES.

4. CLAIMS AND COVERAGE EXCLUSIONS

WARRANTY CLAIMS SHALL BE FILLED IN ACCORDANCE WITH THE PROVISIONS OF THE MHI ENGINE WARRANTY POLICY. WARRANTY COVERAGE SHALL BE EXCLUDED FOR FAILURES OF WARRANTED PARTS WHICH ARE NOT ORIGINAL MHI PARTS OR BECAUSE OF ABUSE, NEGLIGENCE OR IMPROPER MAINTENANCE AS SET FORTH IN THE MHI ENGINE WARRANTY POLICY. MHI IS NOT LIABLE TO COVER FAILURES OR WARRANTED PARTS CAUSED BY THE USE OF ADD-ON, NON-ORIGINAL, OR MODIFIED PARTS.

5. MAINTENANCE

ANY WARRANTED PART WHICH IS NOT SCHEDULED FOR REPLACEMENT AS REQUIRED MAINTENANCE OR WHICH IS SCHEDULED ONLY FOR REGULAR INSPECTION TO THE EFFECT OF "REPAIR OR REPLACE AS NECESSARY" SHALL BE WARRANTED AS TO DEFECTS FOR THE WARRANTY PERIOD. ANY WARRANTED PART WHICH IS SCHEDULED FOR REPLACEMENT AS REQUIRED MAINTENANCE SHALL BE WARRANTED AS TO DEFECTS ONLY FOR THE PERIOD OF TIME UP TO THE FIRST SCHEDULED REPLACEMENT FOR THAT PART. ANY REPLACEMENT PART THAT IS EQUIVALENT IN PERFORMANCE AND DURABILITY MAY BE USED IN THE PERFORMANCE OF ANY MAINTENANCE OR REPAIRS. THE OWNER IS RESPONSIBLE FOR THE PERFORMANCE OF ALL REQUIRED MAINTENANCE, AS DEFINED IN THE MHI OWNER'S MANUAL.

6. CONSEQUENTIAL COVERAGE

COVERAGE HEREUNDER SHALL EXTEND TO THE FAILURE OF ANY ENGINE COMPONENTS CAUSED BY THE FAILURE OF ANY WARRANTED PART STILL UNDER WARRANTY.

NOTES

A large rectangular area with horizontal lines for writing notes. The lines are evenly spaced and cover most of the page's width and height, leaving a margin at the top and bottom. The top and bottom corners of this area are rounded.

Green Machine®

▲ WARNING ▲
 The engine exhaust from this product contains chemicals known to the State of California to cause cancer, birth defects or other reproductive harm.
CALIFORNIA PROPOSITION 65

15911



Green Machine®
 by John Deere

PRODUCT REGISTRATION CARD

Mr. Mrs. Ms. Miss.
 First Name _____ Initial _____ Last Name _____
 Job Title _____ Company Name _____
 Address _____
 City _____ State _____ Zip Code _____ Telephone Number _____
 UT Number _____ Serial Number _____ Date of Purchase _____ Price Paid \$ _____
 Store Name _____ Customer Number _____

Do you plan to purchase any of the following products in the next 1-12 months? (Check all that apply)

	1-6 Months	7-12 Months		1-6 Months	7-12 Months
Backpack Blowers	<input type="checkbox"/>	<input type="checkbox"/>	String Trimmers	<input type="checkbox"/>	<input type="checkbox"/>
Chain Saws	<input type="checkbox"/>	<input type="checkbox"/>	Brushcutters	<input type="checkbox"/>	<input type="checkbox"/>
Handheld Blowers	<input type="checkbox"/>	<input type="checkbox"/>	Edgers	<input type="checkbox"/>	<input type="checkbox"/>
Hedge Trimmers	<input type="checkbox"/>	<input type="checkbox"/>	Walk-Behind Lawn Mowers	<input type="checkbox"/>	<input type="checkbox"/>

How do you classify your company? (Check all that apply)

Lawn Care Company Golf Course
 Landscape Contractor Institutional Grounds Care (parks, government, schools, etc.)
 Chemical Application Other

What other equipment do you use regularly in your business? (Check all that apply)

Backpack Blowers Hedge Trimmers Tillers
 Brushcutters Sprayers (Portable) Vacuums
 Chain Saws Spreaders Walk-Behind Edgers
 Chipper/Shredders Stick Edgers Other
 Hand Held Blowers String Trimmers

Number of people employed by your company:

1 - 14 45 - 59
 15 - 29 60 - 74
 30 - 44 75 +

Mail to: Green Machine®
 Department GM
 P.O. Box 7047
 Charlotte, NC 28241

Green Machine®