

Green Machine®

OWNER'S MANUAL

MODEL 1900e

UT26100

SERIAL NO.

IMPORTANT NOTE: USE THE ABOVE BOX TO FILL IN YOUR MODEL'S SERIAL NUMBER FOR YOUR RECORDS.

ASSEMBLY AND OPERATING INSTRUCTIONS

GREEN MACHINE® - LIMITED WARRANTY

The manufacturer warrants to the original retail purchaser that this Product is free from defects in material and workmanship and agrees to repair or replace, at Manufacturer's discretion, any defective product free of charge within these time periods from the date of purchase:

- Two years, if the Product is used for personal, family, or household use;
- One year, if the Product is used for commercial or any other use.

This warranty is not transferable and does not cover damage resulting from defects other than in material or workmanship, or damage caused by unreasonable use, including the failure to provide reasonable and necessary maintenance. Also, the warranty obligations do not apply to conditions resulting from misuse, alteration, or accident. In addition, this warranty does not cover general check-ups on electrical equipment, tune-ups on gasoline engines, or replacement of non-defective parts (such as electrical brushes, cables, plugs, spark plug, filters, starter ropes, etc.) that may wear and need to be replaced with reasonable use within the warranty period or which may require replacement in connection with normal maintenance. This warranty applies only to products sold within the United States of America, the District of Columbia, Canada, Mexico, the Commonwealth of Puerto Rico, the Virgin Islands, Guam, the Canal Zone, or American Samoa.

SAVE YOUR SALES SLIP

Proof of purchase in the form of your dated sales receipt, cash register slip, etc. showing the serial number and the model of your Product will be required before our dealers can perform warranty service on the Product. You must at your own expense, arrange to deliver or ship the Product for warranty repairs and arrange for pickup or return of the Product after repairs have been made.

This warranty does not apply to any trade accessory, engine, or electric motor which is separately warranted by another manufacturer and not manufactured by the manufacturer.

THIS LIMITED WARRANTY IS IN LIEU OF ALL OTHER EXPRESS WARRANTIES. ANY IMPLIED WARRANTY OF FITNESS FOR A PARTICULAR PURPOSE, MERCHANTABILITY OR OTHERWISE, APPLICABLE TO THIS PRODUCT, SHALL BE LIMITED IN DURATION TO THE DURATION OF THIS LIMITED WARRANTY. THE MANUFACTURER SHALL NOT BE LIABLE FOR ANY SPECIAL, INCIDENTAL OR CONSEQUENTIAL DAMAGES.

SOME STATES DO NOT ALLOW LIMITATIONS ON HOW LONG AN IMPLIED WARRANTY LASTS, SO THE ABOVE LIMITATION MAY NOT APPLY TO YOU. ALSO, SOME STATES DO NOT ALLOW THE EXCLUSION OR LIMITATION OF INCIDENTAL OR CONSEQUENTIAL DAMAGES, SO THE ABOVE LIMITATION OR EXCLUSION MAY NOT APPLY TO YOU.

HOW TO OBTAIN WARRANTY SERVICE

Warranty service can be obtained from a Green Machine® dealer authorized to make warranty repairs. If you need warranty service, check first with the dealer from whom you purchased the Product. **FOR WARRANTY SERVICE INFORMATION OUTSIDE THE USA AND CANADA, PLEASE CONTACT YOUR LOCAL GREEN MACHINE® DEALER.**

The manufacturer will not make any reimbursements for warranty service, except to Green Machine® dealers authorized to make warranty repairs. You must present your sales receipt when making any claim for warranty service.

This warranty gives you specific legal rights, and you may also have other rights which vary from state to state.

This warranty is given by Homelite, Inc. Post Office Box 7047, Charlotte, North Carolina 28241.

Green Machine®

by John Deere

P.O. Box 7047
14401 Carowinds Blvd.
Charlotte, N.C. 28241

P/N 19707

We are pleased that you have chosen a Green Machine® product to assist you with your work. Your Green Machine® product was assembled using the latest manufacturing methods and materials to bring you a product of the highest quality.

This Owner's Manual is provided to aid you in the proper assembly and the safe, reliable operation of your new Green Machine® product. Read it and become thoroughly familiar with the proper operating procedures before you first use this product. Make sure anyone who operates your Green Machine® product is fully acquainted with the proper operating procedures. Careful assembly, safe operation and proper maintenance in accordance with this Owner's Manual will provide you with maximum performance and product life.

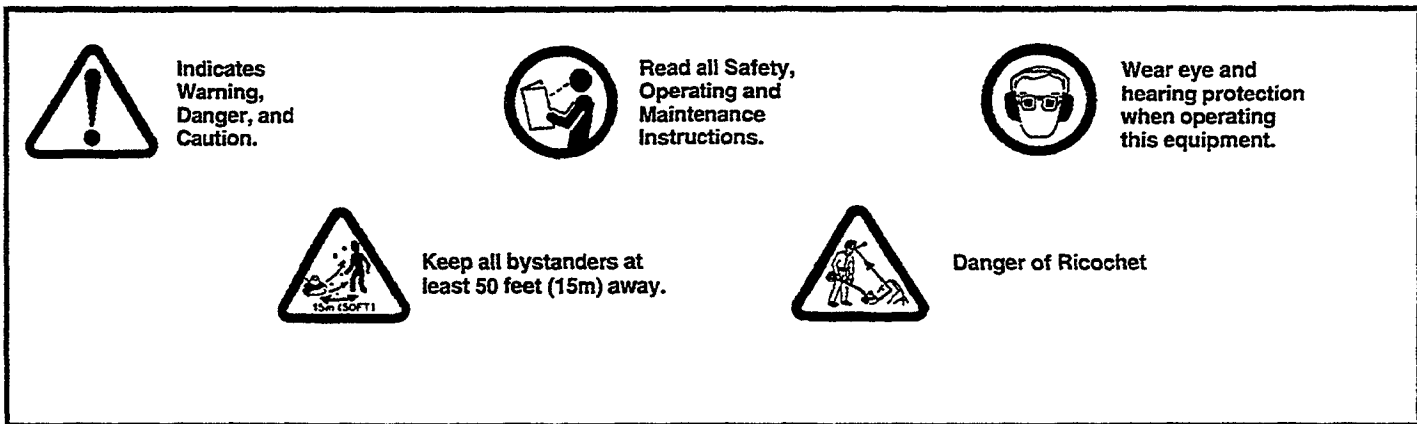

Warning: READ THE OWNER'S MANUAL BEFORE USING YOUR CHAIN SAW. FOLLOW ALL INSTRUCTIONS FOR SAFE OPERATION.

SAFETY INSTRUCTIONS

SAVE THESE INSTRUCTIONS

OPERATION

- Use this unit for cutting recommended material only. Do not use for any other purpose.
- Never start or run the engine inside a closed area, breathing exhaust fumes can kill.
- **CLEAR THE WORK AREA BEFORE EACH USE. REMOVE ALL OBJECTS SUCH AS ROCKS, BROKEN GLASS, NAILS, WIRE, OR STRING WHICH CAN BE THROWN OR BECOME ENTANGLED IN THE BLADE.**
- Be sure the blade is properly installed and securely fastened. Failure to use the proper parts can cause the cutting attachment to fly off and seriously injure the operator and/or bystanders.
- Exposure to vibrations through prolonged use of gasoline powered hand tools could cause blood vessel or nerve damage in the fingers, hands, and wrists of people prone to circulation disorders, or abnormal swellings. Prolonged use in cold weather has been linked to blood vessel damage in otherwise healthy people. If symptoms occur such as numbness, pain, loss of strength, change in skin color or texture, or loss of feeling in the fingers, hands, or wrists, discontinue the use of this tool and seek medical attention.
- **FOLLOW THESE INSTRUCTIONS TO REDUCE THE RISK OF INJURY:**
 - **WEAR FULL EYE AND HEARING PROTECTION WHILE OPERATING THIS EDGER.**
 - Wear heavy long pants, shoes and gloves.
 - Keep all bystanders, children and pets at least 50 feet away.
 - Do not wear loose clothing or jewelry.
 - Secure long hair so it is above the shoulder.
 - Do not operate this edger when you are tired, ill or under the influence of alcohol, drugs or medication.
 - Do not operate in poor lighting.
 - Keep firm footing and balance. Do not overreach.
 - Keep all parts of your body away from the string head and hot surfaces.
- **ALWAYS STOP ENGINE AND REMOVE SPARK PLUG WIRE BEFORE MAKING ANY ADJUSTMENTS OR REPAIRS EXCEPT CARBURETOR ADJUSTMENTS.**

MAINTENANCE

- Use only **GREEN MACHINE®** replacement parts. Failure to do so may cause poor performance and possible injury.
- Inspect unit before each use for loose fasteners, fuel leaks, etc. Replace damaged parts. Replace edger blade if cracked, chipped, or damaged in any way. Be sure the stringhead is properly installed and securely fastened. Failure to do so can cause serious injury.
- Make sure all deflectors and handles are properly and securely attached.

- The cutting head will spin during carburetor adjustments. Wear protective equipment and observe all safety instructions.
- Before storing, allow the engine to cool.
- Empty the fuel tank and restrain the unit from moving before transporting in a vehicle.

REFUELING (DO NOT SMOKE!)

- Mix and store fuel in a container approved for gasoline.
- Mix fuel outdoors where there are no sparks or flames.
- Select bare ground, stop engine, and allow to cool before refueling.
- Loosen fuel cap slowly to release pressure and to keep fuel from escaping around the cap.
- Wipe spilled fuel from the unit. Move 10 feet away from refueling site before starting engine.

BLADE SAFETY

- Before each use, check to be sure that blade is firmly attached. Be sure throttle return to the neutral position when released and that the blade does not rotate at idle.
- A coasting blade can injure while it continues to spin after the engine is stopped or throttle trigger is released. Hold the coasting blade in heavy grass or brush until it stops.
- The front handle must be mounted properly. The front handle will assist in keeping the cutting attachment away from the operator.
- **Exercise extreme caution when using the blade with this unit. BLADE THRUST is the reaction that may occur when the spinning blade contacts anything it cannot cut. This contact may cause the blade to stop for an instant, and suddenly “thrust” the unit away from the object that was hit. This reaction can be violent enough to cause the operator to lose control of the unit. Blade Thrust can occur without warning if the blade snags, stalls, or binds. This is more likely to occur in areas where it is difficult to see the material being cut.**

In order to control the unit when Blade Thrust occurs:

- Main a good comfortable stance and balanced position.
- Always hold the handles firmly with both hands.
- Approach material to be cut from left to right so that the unit will be pulled towards the cut instead of pushed toward the operator.
- Always cut at full throttle. Blade has maximum cutting power and is less likely to stall or bind.
- Keep hands, feet, and unit in proper position.
- Cut only material recommended. Avoid letting blade contact material it can not cut, such as stumps, rocks, metal, etc.

Green Machine
by John Deere

**Model 1900e
Stick Edger™**

The 1900e edges neatly around beds, along walks and drives. GREEN MACHINE has designed this unit to meet the demands of the professional landscaper.

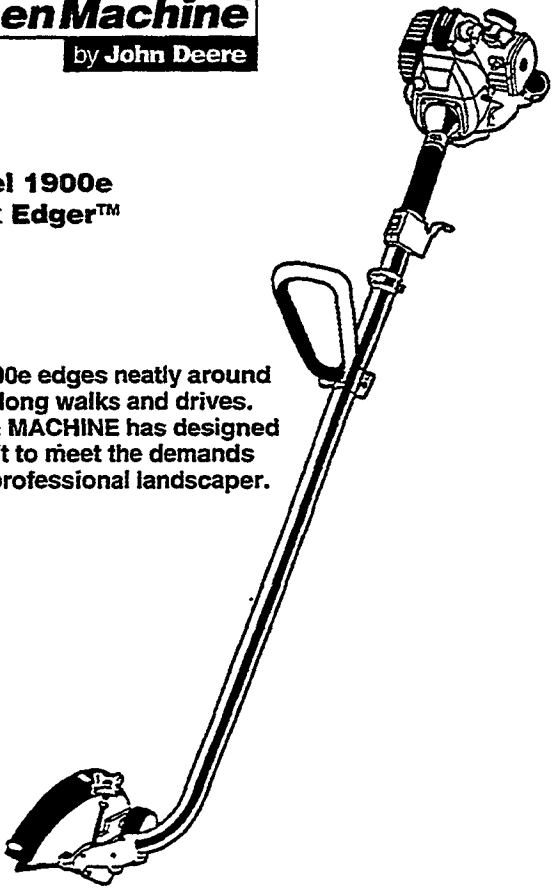

Figure 1

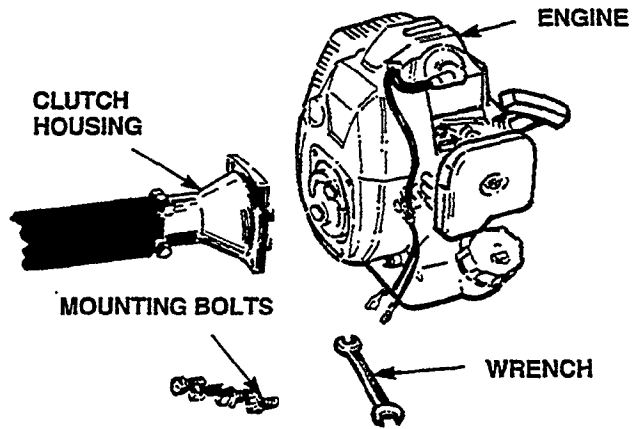

Figure 2

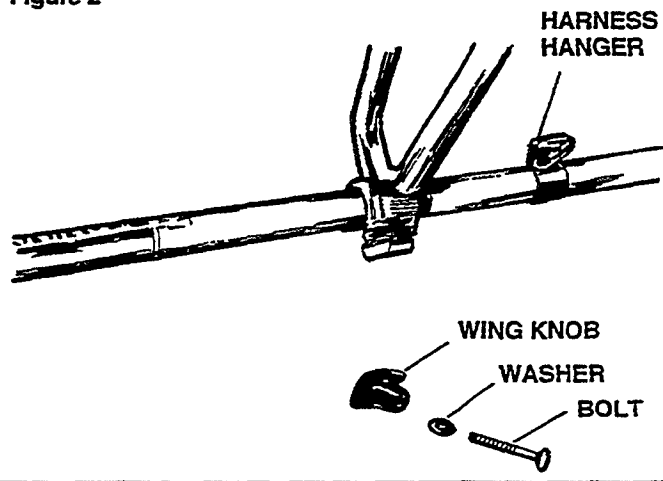
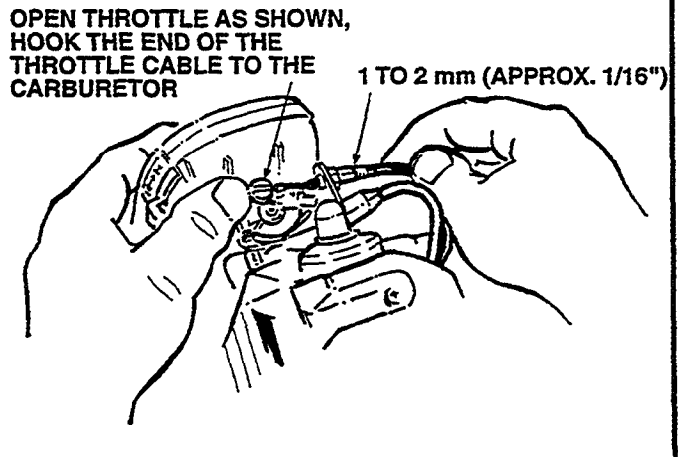

Figure 3



1. ASSEMBLY

Mounting Engine to the Drive shaft

- Using the four (4) bolts supplied, mount the engine to the clutch housing as shown (Figure 1).
- With wrench supplied, tighten all four (4) bolts evenly and securely.

2. INSTALLING MID-HANDLE (Figure 2)

- Snap mid-handle over shaft tube below harness hanger (top of handle should angle back toward engine).
- Install bolt, washer, and wing knob (Figure 2).
- **Note:** Handle may be repositioned for best balance and comfort.

3. INSTALLING THROTTLE CABLE (Figure 3)

- Open throttle as shown, and hook the end of the throttle cable to the carburetor. Carburetor lever attachment has a round hole to accept and capture cable end.

4. SUPPLYING FUEL:

- Fill the fuel tank with fuel to 7/8 full, using a mixed fuel of gasoline and 2 cycle air cooled engine oil.

REFUELING (DO NOT SMOKE!)

- Mix and store fuel in a container approved for gasoline.
 - Mix fuel outdoors where there are no sparks or flames.
 - Select bare ground, stop engine, and allow to cool before refueling.
 - Loosen fuel cap slowly to release pressure and to keep fuel from escaping around the cap.
 - Wipe spilled fuel from the unit. Move 10 feet away from refueling site before starting engine.
 - **Special Note: Never use gasohol. If gasohol is used, engine warranty will be voided. To test for alcohol content in gasoline, an inexpensive gasohol tester is available, order part # GM 27339.**
 - **RECOMMENDED FUEL: THIS ENGINE IS CERTIFIED TO OPERATE ON UNLEADED GASOLINE INTENDED FOR AUTOMOTIVE USE.** Mix Green Machine 32:1 or Green Machine Premium Exact Mix oil with gasoline according to the instructions on the package. If Green Machine oil is not available, use a high quality 2-cycle engine oil mixed at 4 oz. per gallon. **DO NOT USE AUTOMOTIVE OIL OR 2-CYCLE OUT-BOARD OIL.**
- Thoroughly mix the gasoline and 2-cycle oil before pouring the fuel mix into the engine's fuel tank.



WARNING

The fuel tank may be under pressure. Remove the cap slowly to avoid spurting of fuel.

5. INSPECTION

- Always inspect all fasteners for tightness and/or missing parts. Tighten or replace before use.
- Read and understand all safety and operating instructions before use.
- Check for any fuel leaks. If any, correct before use.
- Make sure all air passages are free of dirt, dust, or any other foreign material.
- Inspect air cleaner for cleanliness.

6. STARTING THE ENGINE, WHEN COLD (INITIAL ENGINE STARTING)

- Slide stop switch (on top of trigger) to run position (towards engine).
- Push the primer pump until fuel flows through the clear plastic return line (Figure 4).
- Place choke lever in the closed position (Figure 4).
- Lock throttle lever in the start position as shown in (Figure 5).
- Pull starter rope slowly, until engine compression is felt (Figure 5). Pull the starter in short rapid strokes until engine starts.
- Avoid pulling the rope to its full extension as starter failure could result.
- Once the engine has started, slowly return the choke lever to its open position.



WARNING:

1. Never smoke when refueling or refuel in an area with open flame (such as water heater pilot light). Gasoline vapors spread rapidly and are highly explosive.
2. Always stop engine and wait for it to cool before refueling.
3. Clean up any spills and dispose of clean-up materials.
4. After refueling, move to another area for starting.
5. Never overfill. Fill tank only 7/8 full to avoid spillage.

Figure 4

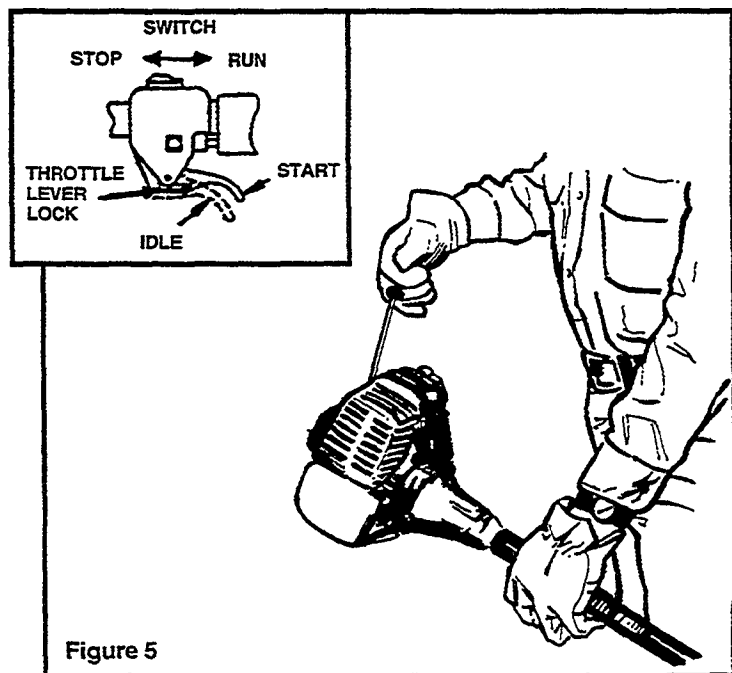
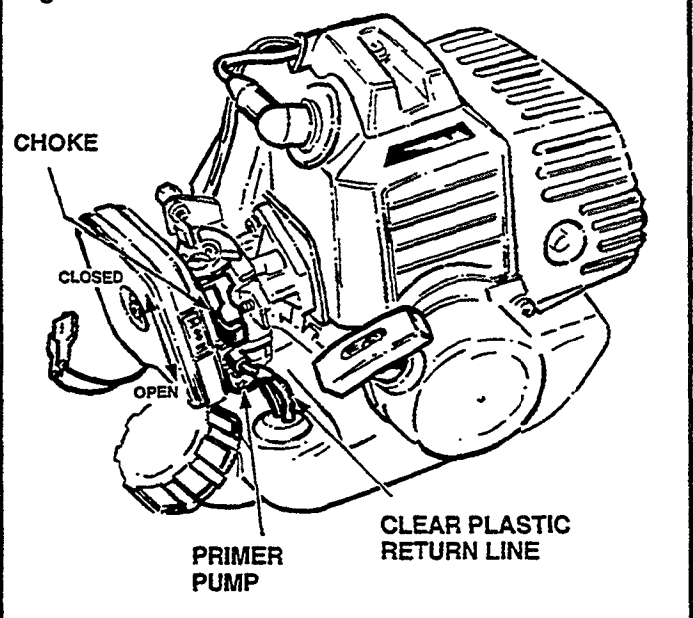

Figure 5

- Return the throttle lever to its idle position.
- Always allow the engine to run 1 to 2 minutes at idle for warm up before starting work.
- **Special Note:**
Place the unit on the ground when starting. Do not use your foot, or knee to hold it down while pulling up on the rope (Figure 6). This will cause the tube and cable to become bent and then break. Never allow the starter rope to snap back.

WHEN WARM (RESTARTING ENGINE)

- Hold throttle lever in the open position.
- Place choke lever in its open position.
- Pull starter rope as outlined in "Starting When Cold".
- **Note:** If engine fails to start, push primer until fuel appears in clear plastic return line.

7. STOPPING ENGINE

- Return throttle lever to its idle position, and allow the engine to idle for a short period (approximately 30 seconds). This allows the engine to cool down.
- Push stop switch to "Stop" position (toward the cutting head). Be sure to return the stop switch to the run position before trying to start unit.
- **Note:** Except for emergencies, avoid stopping engine while it is running at high speed, this avoids overheating the engine.

8. ADJUSTING

- Your Green Machine® engine has been adjusted at the factory for optimum performance and fuel consumption, and no further adjustment should be required. However, because of varying atmospheric and climatic conditions, some minor adjustment may be needed for your area.
- Adjusting idle speed should always be done with a tachometer to insure proper idle speed (2,800 to 3,300 rpm). If a tachometer is not available, the idle speed may be adjusted as follows (Figure 7).
 1. Turn idle speed screw clockwise until cutting head or lower drive begins to move.
 2. Turn idle speed screw counterclockwise until lower drive stops.
 3. Turn idle speed screw approximately 1/4 to 3/4" turn further counterclockwise.
- If the engine does not idle properly after this adjustment, contact your nearest Green Machine® dealer for service.
- Condition of the air cleaner is very important to the operation and life of the engine, and also has a major affect on carburetor adjustments. The air cleaner should be checked for cleanliness before each use, and before making any carburetor adjustments.

Figure 6

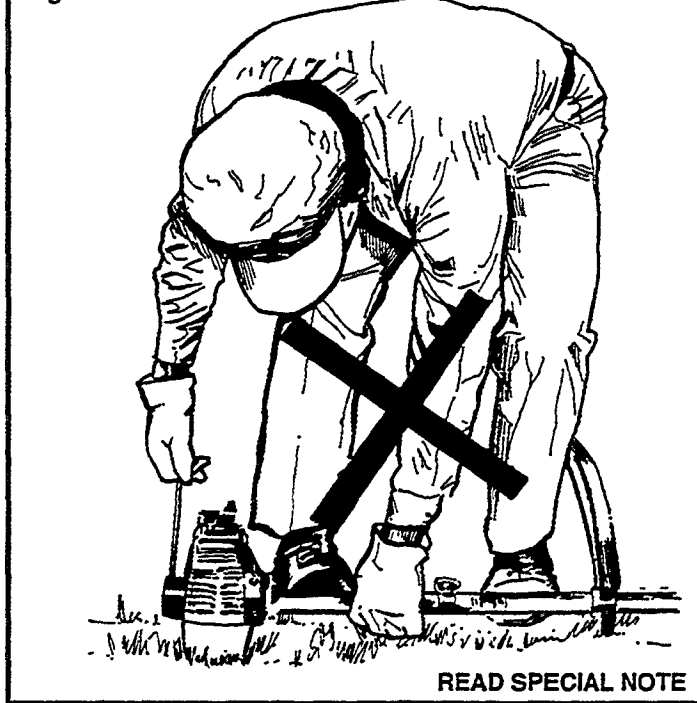
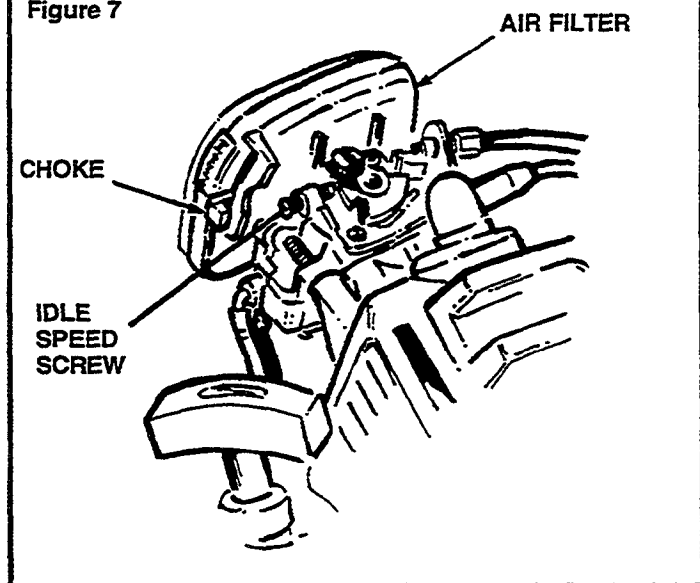

Figure 7



9. MAINTENANCE

Daily

- Carefully inspect complete unit for damaged, loose or missing parts. Correct before use.
- Carefully inspect for any fuel leaks. Correct immediately.
- Check air cleaner for cleanliness.
- Remove all dust, dirt, and grass from the entire unit after each use.

30-Hour Service, or Once a Week for Commercial Use.

- All items under daily service plus:
- Remove, clean, and recap spark plug (0.7mm/0.025 inches) (Figure 8).
- Clean and service air filter (after cleaning, put small amount of engine oil on sponge and squeeze out excess) (Figure 9).
- Check fuel filter in tank and clean if needed. (Figure 9).
- Remove cylinder cover and clean out all dust, dirt, and foreign material.

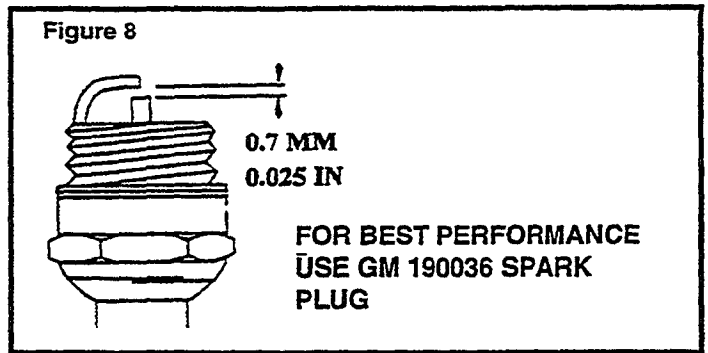

SAFETY

- Before each use always inspect your Green Machine® for loose, missing, damaged or broken parts. Correct before using.
- Always wear approved eye protection (safety goggles).
- Due to the danger of thrown objects and the danger of striking others with the string or blade, keep bystanders and pets away from the work area at all times.
- Do not wear loose fitting clothes while operating unit.
- Never operate unit while barefoot or wearing sandals.
- Never operate unit without shields or guards in place and in good working order.
- Use only genuine Green Machine® blades and rotary heads.
- Never use any type of wire in place of the nylon string.
- Never touch engine or muffler during operation, or immediately after shutdown.
- Never touch spark plug, ignition plug cap, or high tension wire while engine is running.
- Always make sure engine is securely mounted to drive shaft before each use.
- Always check for any fuel leaks before each use and correct before use.
- Never operate unit indoors or in an enclosed area.
- Your Green Machine product is not a toy. Do not allow children to play with it or use it.

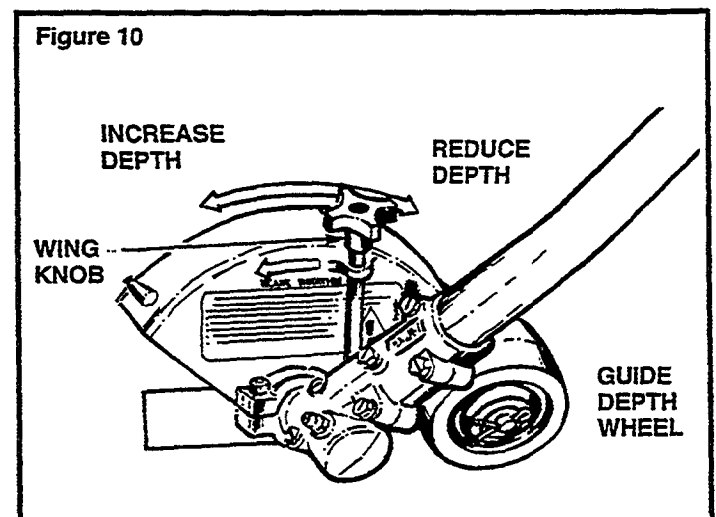
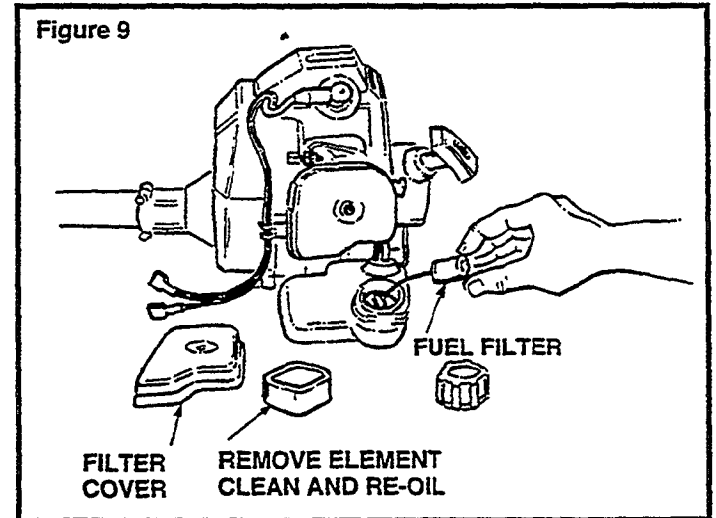

10. OPERATION

- Before using your edger you should adjust the depth of cut by rotating the blade shield, which is attached to the guide/depth wheel (Figure 10).
- To adjust the blade's depth of cut, first loosen the wing knob as shown (Figure 10).



WARNING: Never adjust blade height with engine running.

- Rotating blade shield back (toward the operator) will reduce the cutting depth.
- Rotating forward, will increase the blade's depth of cut (**Figure 11**).
- The best depth setting is that which produces a fine cut line between sidewalk and grass with a minimum of blade depth (usually 1/2 inch of blade in the ground).
- Blade depth may have to be adjusted for each edging job due to different concrete to grass heights.
- It is not recommended to adjust the depth to its maximum where not needed. This will only make the edging work more difficult and shorten blade life.
- To begin edging, first determine which direction you wish to travel so that your walking will not be on the grass. Always operate from left hand side.
- Always survey the area of edging for obstacles and items that may be thrown. Remove both of these dangers before beginning.
- Start the engine and run at half throttle before putting blade into the ground. Gentle lower the blade into the ground at the point you wish to start edging. Be careful not to hit the concrete (**Figure 12**).

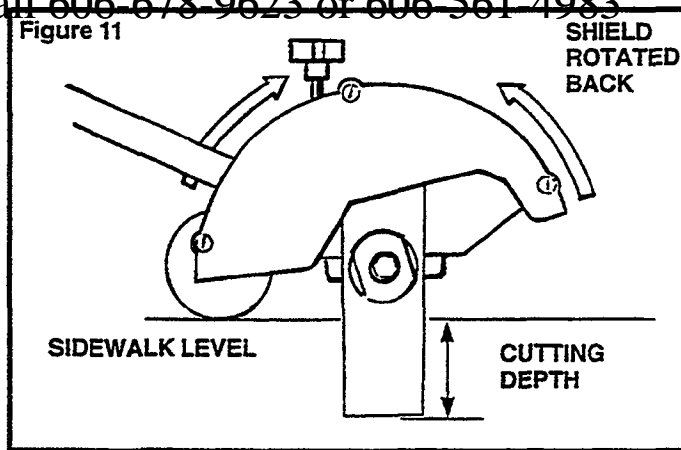

WARNING: Always use eye protection (safety goggles) when edging. Always remove obstacles and throwable objects.

- Move forward as quickly as the blade and its cutting will allow. Do not force it, let the blade do the work.
- Use only as much engine speed as is needed to do the job. Overspeeding will only shorten blade life.
- While edging, try not to allow the blade to touch the concrete.
- The correct handling of your edger is shown in **Figure 12**.
- Note: Sidewalk edges that have not been maintained may require more than one pass to obtain a clean cut. Periodic edging will keep the edge neat and make the job easier.
- It is recommended that a watering of the edge area be done to soften the ground some time before edging.

11. MAINTENANCE

- Before each use, inspect the complete unit for loose or missing fasteners or parts. If found, correct before using.
- Replace blades as needed. Never wear the blade shorter than 3 inches.

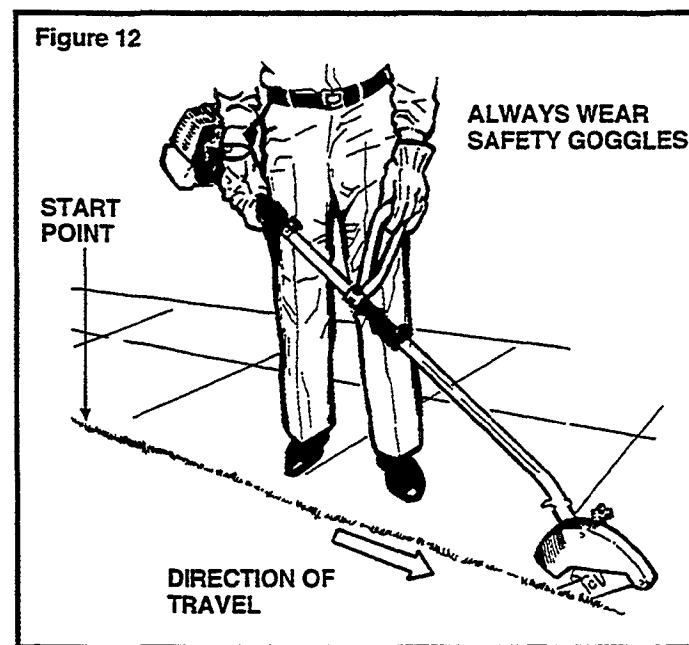

- Each 10 hours of use, the gear case should be regressed by first removing the blade, blade flange washers and seal collar (**Figure 13**).



CAUTION: Greasing without removing blade and flange washers will cause gear and bearing damage.

- To replace the blade or to grease gearbox, first make certain the engine is stopped. Fit spanner wrench supplied onto flats of lower flange washer (**Figure 14**).
- Using suitable wrench, loosen blade bolt by turning clockwise. **NOTE:** left hand thread.
- Remove blade and flange washers for regressing.
- Remove only lower flange washer and old blade if only the blade is being replaced.
- Install the new blade onto upper flange washer. Install lower flange washer and bolt.
- Make certain the blade is properly centered before tightening the blade bolt.
- Turn counterclockwise to tighten the blade bolt.
- Tighten securely.
- Rotate the blade to see that the blade tips do not touch the blade shield at any point.



SAFETY

- Never allow children to operate the edger. It is not a toy.
- Always read and understand the owner's manual before operation.
- Keep area of operation clear of all persons; inspect the area for obstacles and throwable objects.
- Dress properly - Do not wear loose clothes or jewelry. They can be caught in moving parts.
- Never wear sandals or operate barefooted.
- Wear long pants.
- Make certain engine is stopped whenever adjusting blade height or making repairs.
- Always wear safety goggles.
- Keep all fasteners tight to insure that the edger is in safe working condition.
- Never operate without the guard in place.
- Keep bystanders at least 50 feet away.
- Never operate near gravel or in especially rocky soil.
- Never operate from the right hand side.

Figure 13

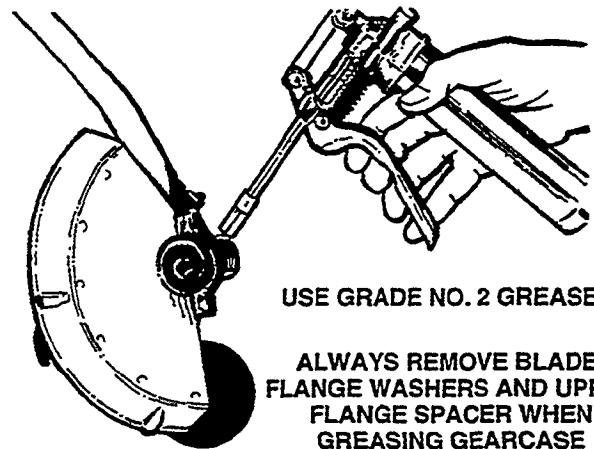

USE GRADE NO. 2 GREASE

ALWAYS REMOVE BLADE, FLANGE WASHERS AND UPPER FLANGE SPACER WHEN GREASING GEARCASE

Figure 14

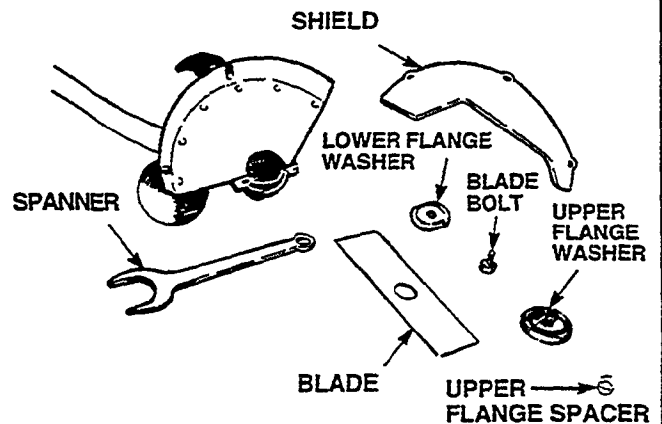

GREEN MACHINE®
TROUBLE SHOOTING CHART

FAILURE OF ENGINE TO START - NO SPARK 1. Failure located on the spark plug side	<ol style="list-style-type: none"> 1. The electrode of spark plug is wet 2. Carbon deposit sticks to the electrodes of spark plug 3. Poor insulation caused by crack, etc. of insulator 4. Undersize or oversize gap of the electrodes of spark plug 5. Burning of the electrodes of spark plug 	<ol style="list-style-type: none"> 1. Dry it 2. Clean it 3. Replace spark plug 4. Adjust the gap to 0.6mm 5. Replace spark plug
2. Failure located on the magneto side	<ol style="list-style-type: none"> 1. Coil burnout 2. Coil poor insulation 3. Cord coating breakage 4. Unit burnout 	<ol style="list-style-type: none"> 1. Replace coil 2. Replace coil 3. Replace or repair cord 4. Replace magneto
HAS SPARK 1. Proper compression and sufficient fuel	<ol style="list-style-type: none"> 1. Engine flooded 2. Use of improper fuel mixture 	<ol style="list-style-type: none"> 1. Remove spark plug and discharge outward with recoil starter 2. Replace with proper fuel 32:1 mix
2. Sufficient supply of fuel but compression is poor	<ol style="list-style-type: none"> 1. Heavy wear of cylinder, piston and piston ring 2. Loose spark plug 	<ol style="list-style-type: none"> 1. Replace all worn parts 2. Tighten
3. No supply of fuel to the carburetor	<ol style="list-style-type: none"> 1. Fuel tank is empty 2. Loose fuel hose fitting or loose carburetor 3. Filter clogging 4. Fuel is available in the tank,, however, fuel does not reach the carburetor 5. Air vent in the fuel tank clogging 	<ol style="list-style-type: none"> 1. Refill the fuel tank 2. Tighten fuel lines or carburetor 3. Clean or replace filter 4. Refer to the starting procedure 5. Clean it
POWER IS NOT SUFFICIENT 1. Compression of engine is normal and there is no mis-firing	<ol style="list-style-type: none"> 1. Air cleaner clogging 2. The muffler is plugged with carbon 3. Air leakage through the pipe fitting, etc. 4. Fuel passage clogging 5. Water is mixed in fuel 	<ol style="list-style-type: none"> 1. Clean 2. Clean the muffler or replace 3. Tighten the fitting securely 4. Clean 5. Replace with proper fuel
2. Overheating is observed	<ol style="list-style-type: none"> 1. Excessive lean fuel mixture 2. Use of improper mixed oil 3. Carbon deposit 4. Fan cover, cylinder fin, etc. are stuffed with dirt 5. Forced operation 	<ol style="list-style-type: none"> 1. Adjust and clean carburetor 2. Replace with 2-cycle 32:1 mix 3. Clean 4. Clean and remove dirt 5. Operate properly
3. Knocking noise is heard	<ol style="list-style-type: none"> 1. Cylinder overheat 2. Use of improper fuel 3. The combustion is covered with carbon deposits 	<ol style="list-style-type: none"> 1. Adjust carburetor, clean cylinder fin 2. Replace with proper fuel: 25:1 mix 3. Clean the combustion chamber
4. Air Suction	<ol style="list-style-type: none"> 1. Loose carburetor 2. Loose fuel pipe 	<ol style="list-style-type: none"> 1. Tighten 2. Insert firmly
ENGINE RUNS BUT TOOL WILL NOT PERFORM	<ol style="list-style-type: none"> 1. Lower tool nut fully engaged in coupler 	<ol style="list-style-type: none"> 1. Refer to owner's manual for proper assembly or see authorized service dealer for assistance
ENGINE STOPS WHILE IN OPERATION 1. Engine stops abruptly	<ol style="list-style-type: none"> 1. Defective stop button 2. Dislocation of plug cap 3. The piston shows score surface with indication of seizure 4. Short circuit of spark plug electrode due to carbon deposit 5. Failure of proper functioning of magneto 	<ol style="list-style-type: none"> 1. Replace 2. Fix firmly 3. Repair or replace 4. Clean 5. Disassemble and replace necessary parts
2. Engine stops gradually	<ol style="list-style-type: none"> 1. Empty fuel tank 2. Inside carburetor clogging 3. Fuel tank clogging 4. Water is mixed in fuel 	<ol style="list-style-type: none"> 1. Refill 2. Disassemble and clean 3. Disassemble and clean breather 4. Replace with proper fuel
ENGINE WILL NOT STOP WHEN TURNED OFF	<ol style="list-style-type: none"> 1. The extreme end portion of spark plug is red-heated 2. Broken stop button 	<ol style="list-style-type: none"> 1. Clean or replace spark plug and adjust the gap to 0.6mm 2. Replace worn part
SHAFT VIBRATES	<ol style="list-style-type: none"> 1. Cord is not in balance - both cords not of same length 2. Cord is worn out 3. Nylon cord head is bent 4. Saw or Brush blade not centered on Upper flange washer 5. Grease or oil has gotten into clutch assembly (clutch housing) 6. Lower gear case is out of grease 	<ol style="list-style-type: none"> 1. Equalize cord length at 6 inches 2. Same as #1 3. Replace arbor post 4. Re-center blade on holders 5. Clean clutch shoes and drum 6. Grease gear case - 30 operating hours

**MITSUBISHI HEAVY INDUSTRIES, LTD. (MHI) AND THE CALIFORNIA AIR RESOURCES BOARD
EMISSION CONTROL SYSTEM WARRANTY STATEMENT
(Owner's Defect Warranty Rights and Obligations)**

In the interest of the environment, MHI engines that meet strict emission requirements are labeled. "This ULGE engine conforms to 1995-1996 California Emission Control Regulations".

California Emission Control Defects Warranty Statement

The California Air Resources Board and MHI are pleased to explain the emission control system warranty on your 1995 utility or lawn and garden equipment engine (ULGE). In California, new utility or lawn and garden equipment engines must be designed, built and equipped to meet the state's stringent anti-smog standards. MHI must warrant the emission control system on your engine for the periods of time listed below. Provided there has been no abuse, neglect or improper maintenance of your utility or lawn and garden equipment engine.

Your emission control system includes parts such as the carburetor, air cleaner, ignition system, muffler and catalytic converter. Also included may be connectors and other emission related assemblies.

Where a warrantable condition exists, MHI will repair your utility or lawn and garden equipment engine at no cost to you including diagnosis, parts and labor.

MITSUBISHI HEAVY INDUSTRIES, LTD. Emission Control Defects Warranty Coverage

The utility or lawn and garden equipment engines are warranted relative to emission control parts defects for a period of two years, subject to provisions set forth below. If any covered part on your engine is defective, the part will be repaired or replaced by MHI.

Owner's Warranty Responsibilities

As the utility or lawn and garden equipment owner, you are responsible for the performance of the required maintenance listed in your Owner's Manual. MHI recommends that you retain all your receipts covering maintenance on your utility or lawn and garden equipment engine, but MHI cannot deny warranty solely for the lack of receipts or for your failure to ensure the performance of all scheduled maintenance.

As the utility or lawn and garden equipment engine owner, you should however be aware that MHI may deny you warranty coverage if your utility or lawn and garden equipment engine or a part has failed due to abuse, neglect, improper maintenance or unproved modifications.

YOU ARE RESPONSIBLE FOR PRESENTING YOUR UTILITY OR LAWN AND GARDEN EQUIPMENT ENGINE TO AN AUTHORIZED SERVICE DEALER OR LAWN AND GARDEN EQUIPMENT MANUFACTURER TO WHOM MHI WOULD SELL ENGINES AS SOON AS A PROBLEM EXISTS. THE UNDISPUTED WARRANTY REPAIRS SHOULD BE COMPLETED IN A REASONABLE AMOUNT OF TIME, NOT TO EXCEED 30 DAYS. IF YOU HAVE ANY QUESTION REGARDING YOUR WARRANTY RIGHTS AND RESPONSIBILITIES, YOU SHOULD CONTACT GREEN MACHINE'S CUSTOMER REPRESENTATIVE AT 1-704-588-3200.

THE EMISSION WARRANTY IS A DEFECTS WARRANTY. DEFECTS ARE JUDGED ON NORMAL ENGINE PERFORMANCE. THE WARRANTY IS NOT RELATED TO AN IN-USE EMISSION TEST.

MITSUBISHI HEAVY INDUSTRIES, LTD. Emission Control Defects Warranty Provisions

The following are specific provisions relative to your Emission Control Defects Warranty Coverage. It is in addition to the MHI engine warranty for non-regulated engines found in the Owner's Manual.

1. WARRANTED PARTS

COVERAGE UNDER THIS WARRANTY EXTENDS ONLY TO THE PARTS LISTED BELOW (THE EMISSION CONTROL SYSTEMS PARTS) TO THE EXTENT THESE PARTS WERE PRESENT ON THE ENGINE PURCHASED.

FUEL METERING SYSTEMS

**CARBURETOR AND INTERNAL PARTS
COLD START ENRICHMENT SYSTEM (SOFT CHOKE)
FUEL FILTER (UP UNTIL THE FIRST SCHEDULED CHANGE)
FUEL INLET HOSE
FUEL OUTLET HOSE**

AIR INDUCTION SYSTEM

AIR FILTER (ELEMENT)

IGNITION SYSTEM

**SPARK PLUG(S)
MAGNETO IGNITION SYSTEM**

2. LENGTH OF COVERAGE

MHI WARRANTS TO THE INITIAL OWNER AND EACH SUBSEQUENT PURCHASER THAT THE WARRANTED PARTS SHALL BE FREE FROM DEFECTS IN MATERIALS AND WORKMANSHIP WHICH CAUSE THE FAILURE OF THE WARRANTED PART(S) FOR A PERIOD OF TWO YEARS FROM THE DATE THE ENGINE IS DELIVERED TO A RETAIL PURCHASER.

3. NO CHARGE

REPAIR OR REPLACEMENT OF ANY WARRANTED PART WILL BE PERFORMED AT NO CHARGE TO THE OWNER, INCLUDING DIAGNOSTIC LABOR WHICH LEADS TO THE DETERMINATION THAT A WARRANTED PART IS DEFECTIVE, IF THE DIAGNOSTIC WORK IS PERFORMED AT AN AUTHORIZED SERVICE DEALER OF LAWN AND GARDEN EQUIPMENT MANUFACTURER TO WHOM MHI WOULD SELL ENGINES.

4. CLAIMS AND COVERAGE EXCLUSIONS

WARRANTY CLAIMS SHALL BE FILLED IN ACCORDANCE WITH THE PROVISIONS OF THE MHI ENGINE WARRANTY POLICY. WARRANTY COVERAGE SHALL BE EXCLUDED FOR FAILURES OF WARRANTED PARTS WHICH ARE NOT ORIGINAL MHI PARTS OR BECAUSE OF ABUSE, NEGLIGENCE OR IMPROPER MAINTENANCE AS SET FORTH IN THE MHI ENGINE WARRANTY POLICY. MHI IS NOT LIABLE TO COVER FAILURES OR WARRANTED PARTS CAUSED BY THE USE OF ADD-ON, NON-ORIGINAL, OR MODIFIED PARTS.

5. MAINTENANCE

ANY WARRANTED PART WHICH IS NOT SCHEDULED FOR REPLACEMENT AS REQUIRED MAINTENANCE OR WHICH IS SCHEDULED ONLY FOR REGULAR INSPECTION TO THE EFFECT OF "REPAIR OR REPLACE AS NECESSARY" SHALL BE WARRANTED AS TO DEFECTS FOR THE WARRANTY PERIOD. ANY WARRANTED PART WHICH IS SCHEDULED FOR REPLACEMENT AS REQUIRED MAINTENANCE SHALL BE WARRANTED AS TO DEFECTS ONLY FOR THE PERIOD OF TIME UP TO THE FIRST SCHEDULED REPLACEMENT FOR THAT PART. ANY REPLACEMENT PART THAT IS EQUIVALENT IN PERFORMANCE AND DURABILITY MAY BE USED IN THE PERFORMANCE OF ANY MAINTENANCE OR REPAIRS. THE OWNER IS RESPONSIBLE FOR THE PERFORMANCE OF ALL REQUIRED MAINTENANCE, AS DEFINED IN THE MHI OWNER'S MANUAL.

6. CONSEQUENTIAL COVERAGE

COVERAGE HEREUNDER SHALL EXTEND TO THE FAILURE OF ANY ENGINE COMPONENTS CAUSED BY THE FAILURE OF ANY WARRANTED PART STILL UNDER WARRANTY.

Green Machine

▲ WARNING ▲
 The engine exhaust from this product contains chemicals known to the State of California to cause cancer, birth defects or other reproductive harm.
CALIFORNIA PROPOSITION 65

15911



Green Machine®
 by **John Deere**

PRODUCT REGISTRATION CARD

Mr. Mrs. Ms. Miss.
 First Name _____ Initial _____ Last Name _____
 Job Title _____ Company Name _____
 Address _____
 City _____ State _____ Zip Code _____ Telephone Number _____
 UT Number _____ Serial Number _____ Date of Purchase _____ Price Paid \$ _____
 Store Name _____ Customer Number _____

Do you plan to purchase any of the following products in the next 1-12 months? (Check all that apply)

	1-6 Months	7-12 Months		1-6 Months	7-12 Months
Backpack Blowers	<input type="checkbox"/>	<input type="checkbox"/>	String Trimmers	<input type="checkbox"/>	<input type="checkbox"/>
Chain Saws	<input type="checkbox"/>	<input type="checkbox"/>	Brushcutters	<input type="checkbox"/>	<input type="checkbox"/>
Handheld Blowers	<input type="checkbox"/>	<input type="checkbox"/>	Edgers	<input type="checkbox"/>	<input type="checkbox"/>
Hedge Trimmers	<input type="checkbox"/>	<input type="checkbox"/>	Walk-Behind Lawn Mowers	<input type="checkbox"/>	<input type="checkbox"/>

How do you classify your company? (Check all that apply)

<input type="checkbox"/> Lawn Care Company	<input type="checkbox"/> Golf Course
<input type="checkbox"/> Landscape Contractor	<input type="checkbox"/> Institutional Grounds Care (parks, government, schools, etc.)
<input type="checkbox"/> Chemical Application	<input type="checkbox"/> Other

What other equipment do you use regularly in your business? (Check all that apply)

<input type="checkbox"/> Backpack Blowers	<input type="checkbox"/> Hedge Trimmers	<input type="checkbox"/> Tillers
<input type="checkbox"/> Brushcutters	<input type="checkbox"/> Sprayers (Portable)	<input type="checkbox"/> Vacuums
<input type="checkbox"/> Chain Saws	<input type="checkbox"/> Spreaders	<input type="checkbox"/> Walk-Behind Edgers
<input type="checkbox"/> Chipper/Shredders	<input type="checkbox"/> Stick Edgers	<input type="checkbox"/> Other
<input type="checkbox"/> Hand Held Blowers	<input type="checkbox"/> String Trimmers	

Number of people employed by your company:

<input type="checkbox"/> 1 - 14	<input type="checkbox"/> 45 - 59
<input type="checkbox"/> 15 - 29	<input type="checkbox"/> 60 - 74
<input type="checkbox"/> 30 - 44	<input type="checkbox"/> 75 +

Mail to: Green Machine®
 Department GM
 P.O. Box 7047
 Charlotte, NC 28241

Green Machine®