

For Serial Nos.
670,000 & Higher

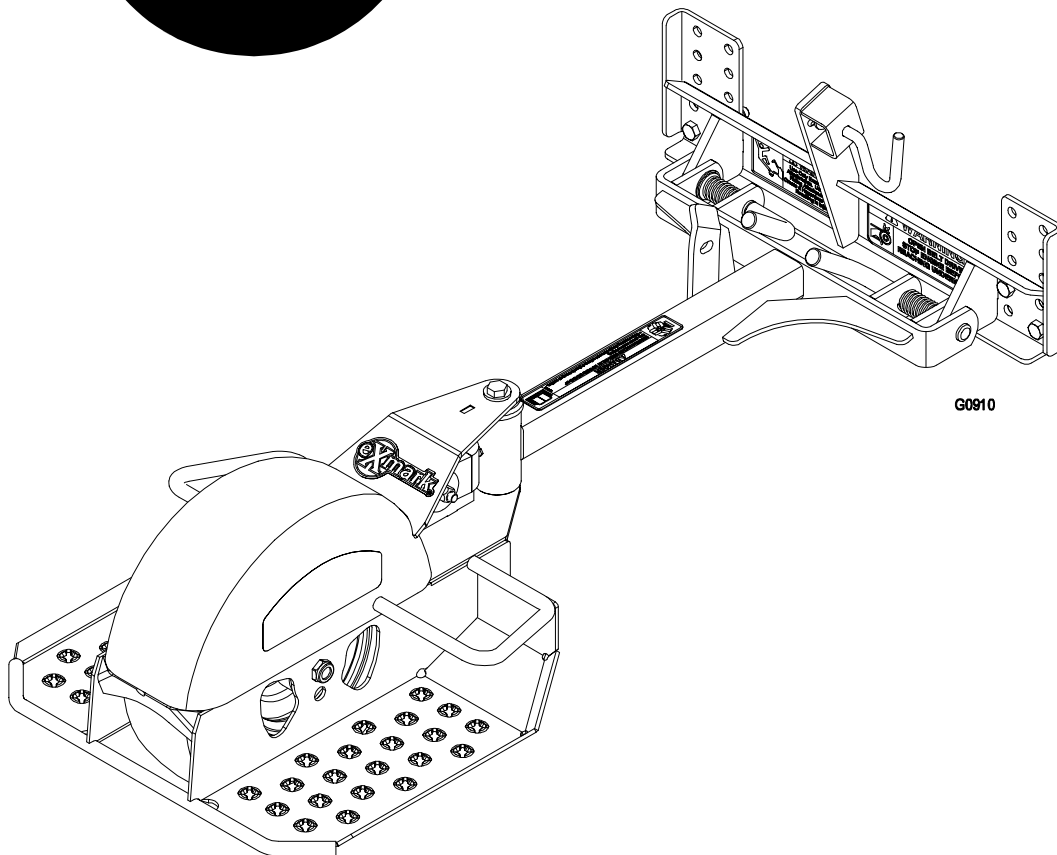

STANDON

CONGRATULATIONS on the purchase of your new Exmark equipment. This product has been carefully designed and manufactured to give you a maximum amount of dependability and years of trouble-free operation. If additional information is needed, or should you require trained mechanic service, contact your authorized Exmark equipment dealer or distributor. If you need to order replacement parts from your dealer, always give the model number and serial number of your equipment as well as the part number, description and quantity of the part needed.

The Serial No. plate is located on the bottom center surface of the sulky frame under the pull arm. For ease of ordering and reference, we suggest that you record the information requested in the following identification table.

Place Model No. and Serial No. Label Here (Included in Literature Pack) or Fill in Below
Model No. _____
Serial No. _____

Date Purchased _____

OPERATOR'S & PARTS MANUAL

EXMARK PARTS PLUS® PROGRAM

EFFECTIVE DATE: September 1, 1995

Program

If your Exmark dealer does not have the Exmark part in stock, Exmark will get the parts to the dealer the next business day or the part will be FREE* Guaranteed!!

How the Program Works

1. If dealer does not have part in stock for a "down" unit at the time of request by customer, the dealer contacts his distributor by 1:00 p.m., local time, and requests Exmark Parts Plus® shipment of six (6) line items or less.
2. Distributor ships part(s) to dealer or customer, as requested by dealer, same day, overnight UPS. Distributor bills dealer for part and freight charges where applicable.
3. If distributor does not have the part(s) in stock to satisfy Exmark Parts Plus® order, he contacts Exmark by 3:00 p.m., central time, with an Exmark Parts Plus® order of six (6) line items or less.
4. If order is received by 3:00 p.m. central time, Exmark ships part(s) direct to dealer or customer, as requested by distributor, same day, overnight UPS, Exmark bills the distributor for parts and shipping charges, where applicable.
5. The customer pays for the part and freight if it is shipped under the Exmark Parts Plus® and if it arrives in accordance to the program.
6. Who pays for the part and freight if it fails to arrive overnight in accordance to the program?
 - A. Under any circumstance the customer does not pay.
 - B. If the part does not arrive overnight due to:
 1. The dealer not submitting the Exmark Parts Plus® order to his Exmark distributor by 1:00 p.m., the dealer pays for the part and freight.
 2. The Distributor being unable to ship the part the same day or not submitting the Exmark Parts Plus® order to Exmark by 3:00 p.m., central time, the Distributor pays for the part and freight.
 3. Exmark being unable to ship the part and the Exmark parts order is received by 3:00 p.m., central time, Exmark pays for the part and freight.
 4. If the part does not arrive overnight due to the shipper (UPS), the shipper pays for the freight and Exmark pays for the part.

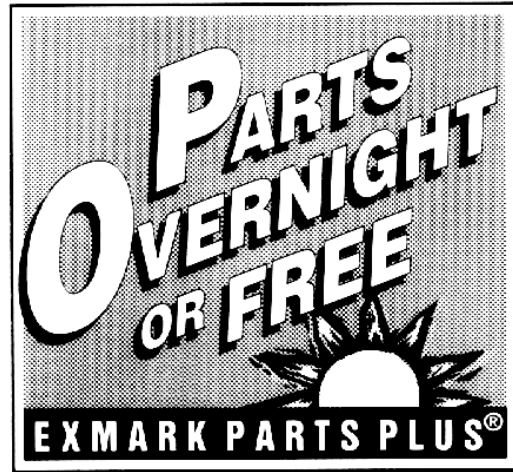

The following restrictions apply -- The Exmark Parts Plus® Program is available only through participating Exmark Dealers and applies only to orders submitted on this program Monday through Thursday. Parts Plus service is available only in the 48 contiguous United States. UPS has initiated a Saturday delivery program to many areas of the continental United States and can be requested for an overnight shipment on Friday to be delivered Saturday. The next day air charge, plus the Saturday delivery fee will be the responsibility of the purchaser. Exmark Mfg. will assume no responsibility for Saturday delivery shipments. To qualify, all Exmark Parts Plus® orders must be received by Exmark by 3:00 p.m., central time. Orders must be six (6) line items or less. Exclusions from the Exmark Parts Plus® Program are: Any wholegood or accessory in its entirety, engines and engine replacement parts, 5-speed Peerless transmissions and 5-speed transaxles, hydraulic or hydrostatic wheel motors, cutter decks and engine decks or any item exceeding United Parcel Service size and weight restrictions.

Due to UPS restrictions, aerosol spray paint is considered a hazardous material and cannot be shipped via UPS next day or Second Day Air.

Exmark Manufacturing stocks a limited supply of parts for transaxles, pumps and wheel motors. These parts can be ordered for Next Day Air shipment but will not be guaranteed per the Parts Plus Program.

OPERATOR'S MANUAL

This manual contains assembly, operating, maintenance, adjustment, and safety instructions for your Exmark StandOn.

BEFORE OPERATING YOUR STANDON, CAREFULLY READ THIS MANUAL AND THE MANUAL FOR YOUR MOWER IN THEIR ENTIRETY.

By following the assembly, operating, maintenance, and safety instructions, you will prolong the life of your StandOn, maintain its maximum efficiency, and promote safe operation.

If additional information is needed, or should you require trained mechanic service, contact your authorized Exmark equipment dealer or distributor.

All Exmark equipment dealers and distributors are kept informed of the latest methods of servicing and are equipped to provide prompt and efficient service in the field or at their service stations. They carry ample stock of service parts or can secure them promptly for you from the factory.

All Exmark parts are thoroughly tested and inspected before leaving the factory; however, attention is required on your part if you are to obtain the fullest measure of satisfaction and performance.

TABLE OF CONTENTS

	PAGE
1. SAFETY	
1.1 Safety Alert Symbol.....	1
1.2 Training.....	1
1.3 Preparation	1-2
1.4 Operation	2-3
1.5 Safety Signs.....	3-4
2. SPECIFICATIONS	
2.1 Model Numbers.....	4
2.2 Dimensions	4
2.3 Tire	4
3. ASSEMBLY INSTRUCTIONS	
3.1 Assembly Diagram.....	5
3.2 Installing the StandOn to Mower	5-8
4. OPERATION INSTRUCTIONS	
4.1 Pre-Start	8
4.2 Mowing	9
4.3 Transporting.....	9
5. MAINTENANCE	9-10
6. ADJUSTMENTS	11
7. PARTS LIST	12
8. WARRANTY	13

1. SAFETY

1.1 SAFETY ALERT SYMBOL

This SAFETY ALERT SYMBOL  is used both in this manual and on the machine to identify important safety messages which must be followed to avoid accidents. This symbol means:

**ATTENTION! BECOME ALERT!
YOUR SAFETY IS INVOLVED!**

The safety alert symbol appears above information which alerts you to unsafe actions or situations and will be followed by the word **DANGER**, **WARNING**, or **CAUTION**.

DANGER: White lettering/Red background. Indicates an imminently hazardous situation which, if not avoided, **WILL** result in death or serious injury.

WARNING: Black lettering/Orange background. Indicates a potentially hazardous situation which, if not avoided, **COULD** result in death or serious injury.



CAUTION: Black lettering/Yellow background. Indicates a potentially hazardous situation which, if not avoided, **MAY** result in minor or moderate injury.

1.2 TRAINING

- 1.2.1 Regard the Exmark mower as a piece of power equipment and teach this regard to all who operate this unit.
- 1.2.2 Before operating your StandOn, carefully read and understand this manual and the operator's manual for your mower in their entirety. Familiarize yourself with the controls and the proper use of the equipment. If the operator(s) or mechanic(s) can not read English it is the owner's responsibility to explain this material to them.
- 1.2.3 Do not allow operation of this machine by untrained personnel. Never allow children, teenagers, or people unfamiliar with these instructions to use the mower. Local regulations may restrict the age of the operator.
- 1.2.4 Avoid mowing while people, especially children, or pets, are nearby. Keep in mind that the operator or user is responsible for accidents or hazards occurring to other people or their property.
- 1.2.5 Only allow the machine operator on the StandOn.

1.3 PREPARATION

- 1.3.1 Do not modify the StandOn and only use on approved Exmark machines.
- 1.3.2 The use of personal protective equipment, such as (but not limited to) protection for the eyes, ears, feet, and head is recommended.



 CAUTION 	
POTENTIAL HAZARD <ul style="list-style-type: none">◆ The mower that the StandOn attaches to may produce sound levels in excess of 85 dBA at the operator's ear when in operation.	
WHAT CAN HAPPEN <ul style="list-style-type: none">◆ Exposure to sound levels of 85 dBA or above for extended periods of time can cause hearing loss.	
HOW TO AVOID THE HAZARD <ul style="list-style-type: none">◆ Wear hearing protection when operating the mower and this attachment.	

- 1.3.3 While mowing, always wear substantial footwear and long trousers. Do not operate equipment when barefoot or when wearing open sandals.
- 1.3.4 Thoroughly inspect the area where the equipment is to be used and remove all stones, sticks, wires, bones, and other foreign objects which may damage the equipment or cause personal injury to the operator or bystanders.

1.4 OPERATION

Although hazard control and accident prevention are partially dependent upon the design and configuration of the equipment, these factors are also dependent upon the awareness, concern, prudence, and proper training of the personnel involved in the operation, transport, maintenance, and storage of the equipment. It is essential that all Operator Safety Mechanisms be connected and in operating condition prior to use. Refer to the Operator's Manual for the mower for additional hazard control and accident prevention information.

- 1.4.1 Use **EXTREME** caution when operating on slopes as loss of traction and/or tip-over could occur. The operator is responsible for safe operation on slopes.

 DANGER 	
POTENTIAL HAZARD	
◆ Operating on a wet grass or steep slope can cause sliding and loss of control.	
WHAT CAN HAPPEN	
◆ Loss of control and/or loss of operator's footing could result in a fall with an arm or leg getting under the mower or engine deck, which may result in serious injury or death.	
HOW TO AVOID THE HAZARD	
◆ Mow across slopes, never up and down.	
◆ Do not mow slopes when grass is wet.	
◆ Do not mow near drop-offs or water.	
◆ Do not mow slopes greater than 20 degrees.	
◆ Reduce speed and use extreme caution on slopes.	
◆ Avoid sudden turns or rapid speed changes.	

- Progressively greater care is needed as the slope increases.
- Always avoid sudden starting or stopping on a slope. If tires lose traction disengage the blades and proceed slowly off the slope.
- Be aware the loss of traction may occur going downhill. Weight transfer to the front wheels may cause drive wheels to slip and cause loss of braking and steering.
- Watch for ditches, holes, rocks, dips, and rises that change the operating angle, as rough terrain could overturn the machine.
- Remove or mark obstacles such as rocks, tree limbs, etc. from the mowing area. Tall grass can hide obstacles.
- Always install and remove the StandOn, as instructed. Failure to do so will cause a reduction in stability or traction.

1.4.2 Stop engine and wait for all moving parts to stop. Remove key and engage park brake whenever leaving the mower.

1.5 SAFETY SIGNS

- 1.5.1 Keep all safety signs legible. Remove all grease, dirt and debris from safety signs and instructional labels.
- 1.5.2 Safety signs must be replaced if they are missing or illegible.
- 1.5.3 When new components are installed, be sure that current safety signs are affixed to the replaced components.
- 1.5.4 New safety signs may be obtained from your authorized Exmark equipment dealer or distributor or from Exmark Mfg. Co. Inc.
- 1.5.5 Safety signs may be affixed by peeling off the backing to expose the adhesive surface. Apply only to a clean, dry surface. Smooth to remove any air bubbles.

1.5.6 Familiarize yourself with the following safety signs and instruction labels. They are critical to the safe operation of your Exmark StandOn.

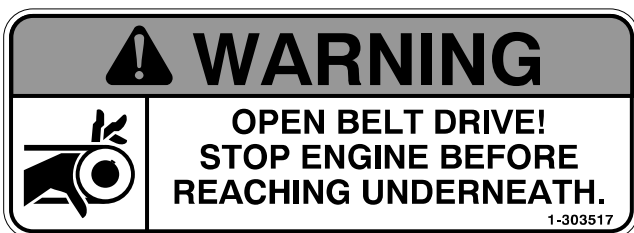

PART NO. 1-303517
 LOCATION: Rear Surface of Pull Frame
 Rear Surface of Mower Engine Deck



PART NO. 1-403143
 LOCATION: Rear Surface of Pull Frame
 Rear Surface of Mower Engine Deck

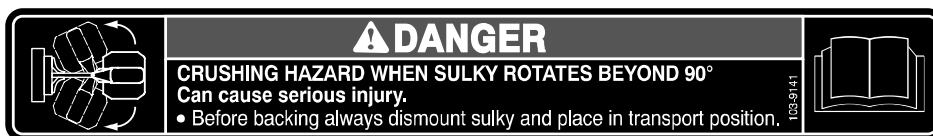

PART NO. 103-9141
 LOCATION: Top Surface of Pull Arm

2. SPECIFICATIONS

2.1 MODEL NUMBER: STANDON

2.2 DIMENSIONS:

Length	Width	Height	Weight
35.4 in. (89.9 cm)	18.5 in. (47.0 cm)	14.9 in. (37.9 cm)	50 lbs. (23 kg)

2.3 TIRE:

	Tread	Size
Semi-Pneumatic Tire	Smooth	11 x 4.00-5

For Operator's over 250 lbs. it is recommended to use pneumatic tire assembly P/N 103-3798.

3. ASSEMBLY INSTRUCTIONS

3.1 ASSEMBLY DIAGRAM

Item	Qty	Description
1	8	Nut, Nyloc 3/8-16 Flg
2	2	Plate, Back-Up
3	2	Plate, Adapter
4	8	Screw, HH 3/8-16 X 1 1/4
5	1	Asm, Frame Pull W/Decals
6	1	Asm, Pull Arm W/Brgs
7	1	Guard, Top
8	1	Screw, HH 3/8-16 x 4 3/4
9	1	Nut, Hex Flg-Side Lock, 3/8-16
10	1	Asm, Sulky Frame W/Decals
11*	2	Replacement Decals (Turf Tracer and Viking Hydro Only)
12	1	Washer, Disc Spring

* Not shown in illustration

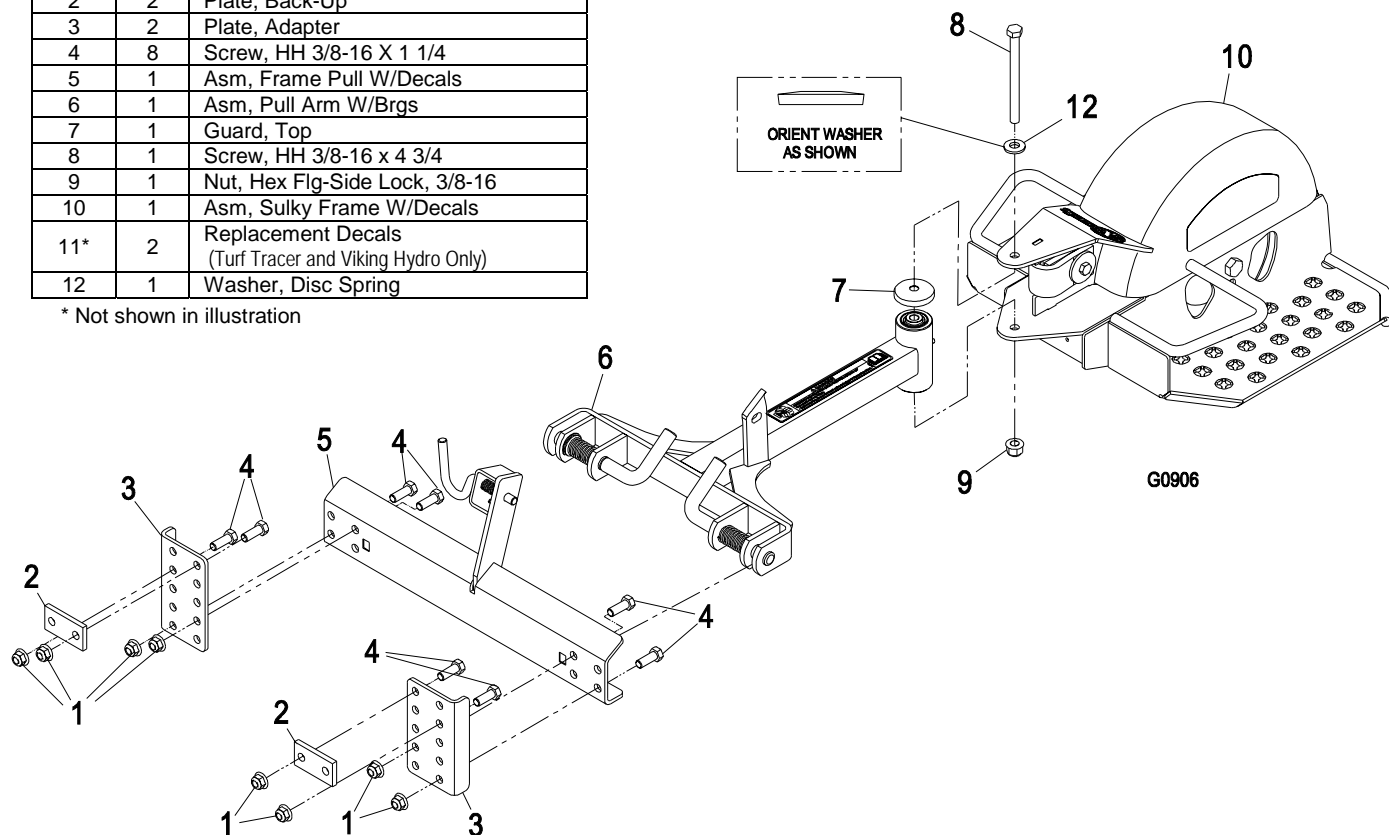

3.2 INSTALLING STANDON RIDER TO MOWER

3.2.1 MOUNTING PULL FRAME

1. Locate pull frame (Item 5) and (2) mount brackets (Item 3). Install the pull frame to the mount brackets using (4) 3/8-16 x 1 1/4 Hex capscrews (Item 4) and (4) 3/8-16 nyloc nuts (Item 1) as shown in Figure 1.

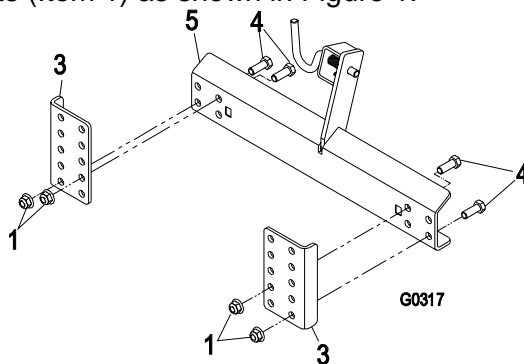

FIGURE 1

For Turf Tracer and Viking Hydro Units:

2. Remove the two decals on the lower rear surface of the engine deck. See Figure 2.

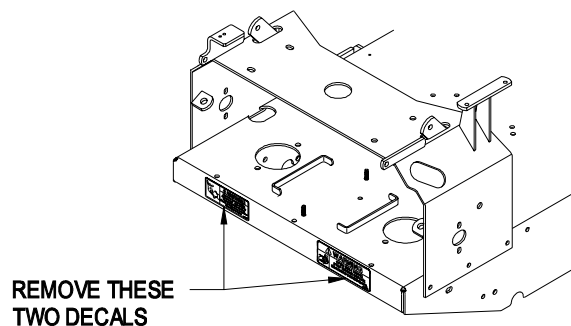

FIGURE 2

G0327

3. Center the mount brackets on lower rear surface of mower engine deck and mark (4) hole locations as shown in Figure 3. Drill (4) 0.407" diameter holes through the engine deck at the marked locations.

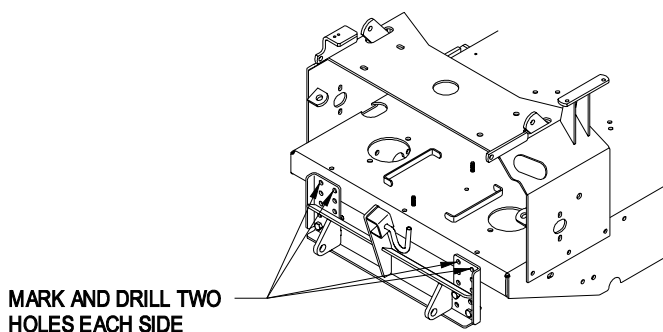

FIGURE 3

G0318

4. Apply the (2) replacement decals (Item 11) to the engine deck between the mounting holes. See Figure 4.

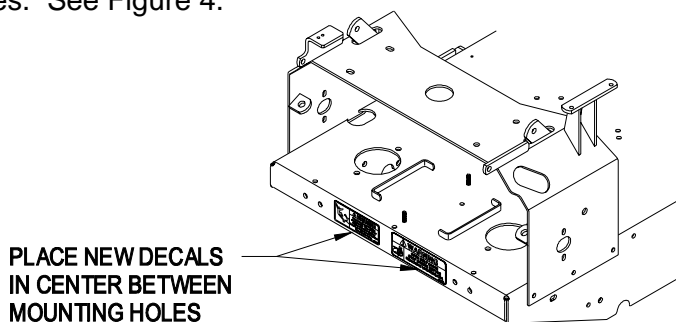

FIGURE 4

G0328

5. Align pull frame and mount bracket assembly to rear surface of engine deck. Measure the distance from the bottom of the pull frame to the ground. Choose mount holes that will attain a distance of approximately 8".
Install the mount brackets to the mower engine deck using (2) 3/8-16 x 1 1/4 hex capscrews (Item 4), (2) back-up plates (Item 2), and (2) 3/8-16 nyloc nuts (Item 1) as shown in Figure 5.

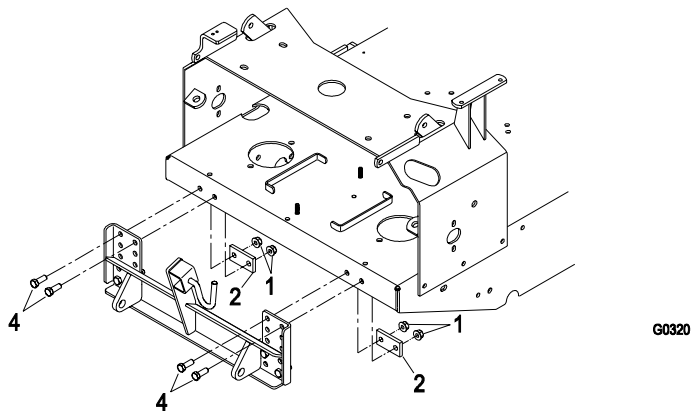

FIGURE 5

For Turf Tracer HP and Metro HP Units:

2. Align pull frame and mount bracket assembly to rear surface of engine deck. Measure the distance from the bottom of the pull frame to the ground. Choose mount holes that will attain a distance of approximately 8".
3. Install the mount brackets to the mower engine deck using (2) 3/8-16 x 1 1/4 hex cap screws (Item 4) and (2) 3/8-16 flanged nyloc nuts (Item 1) as shown in Figure 6.

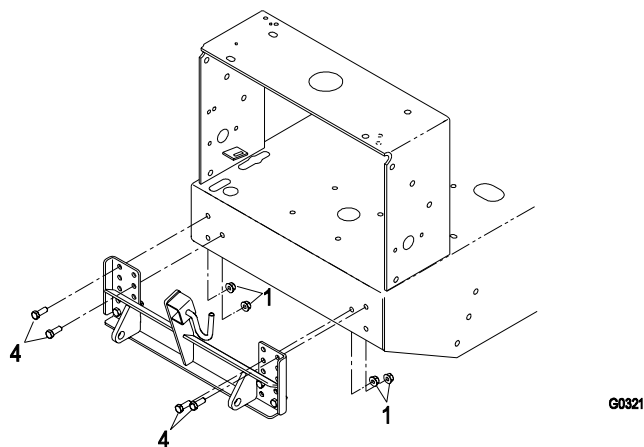

FIGURE 6

3.2.2 MOUNTING THE PULL ARM AND PLATFORM

For Turf Tracer, Turf Tracer HP, Metro HP, and Viking Hydro Units:

4. Locate the pull arm assembly (Item 6). Align pull arm assembly with pull frame (Item 5) as shown in Figure 7. Squeeze quick connect pins on pull arm assembly and attach pull arm assembly to pull frame.

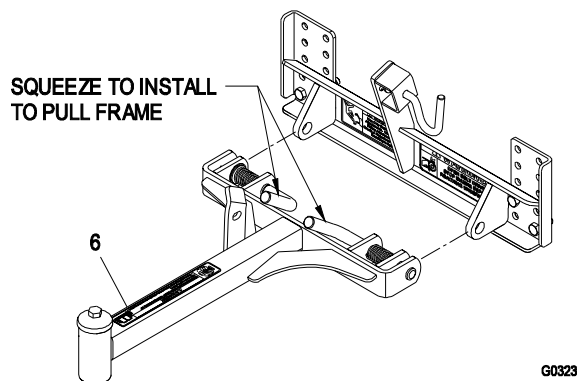

FIGURE 7

5. Remove the 3/8-16 x 4 3/4 hex capscrew (Item 8), Disc spring washer (Item 12), and 3/8-16 Hex Flange side lock nut (Item 9) from the pivot hub. See Figure 8.
6. Locate the Sulky frame assembly (Item 10) and align with the pull arm assembly. Re-install the 3/8-16 x 4 3/4 hex capscrew (Item 8), Disc spring washer (Item 12) (orient as shown), and 3/8-16 Hex Flange side lock nut (Item 9) removed in step 4 as shown in Figure 8. Torque to 35-38 ft-lbs.

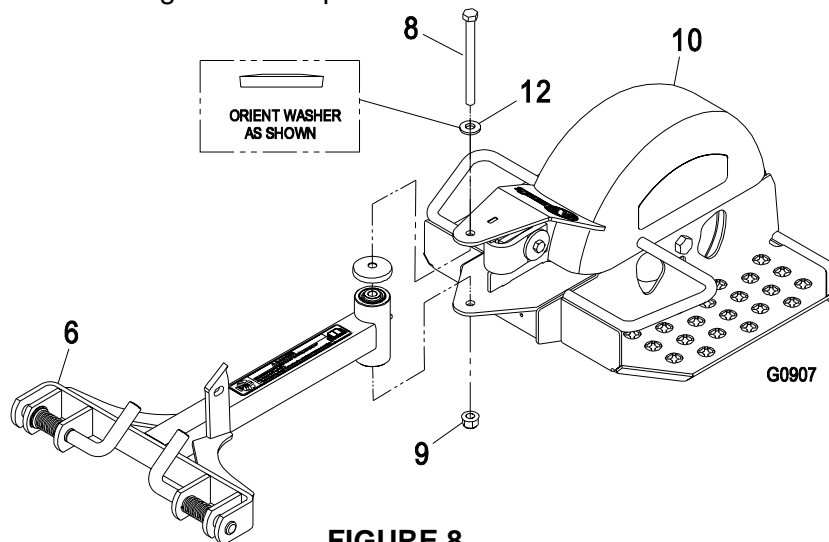

FIGURE 8

NOTE: For optimal performance, the StandOn pull arm top surface should be horizontal to the ground surface. To obtain a position as close to horizontal as possible, the mounting brackets and the platform wheel can be repositioned. See Section 6 for adjustment.

4. OPERATION INSTRUCTIONS

4.1 PRE-START

1. Read the operator's manual for your mower and familiarize yourself with all controls before operating the machine. Make sure that you understand the controls, their locations, functions, and safety requirements.
2. Practice operating the machine without the StandOn until familiar with the controls.
3. Practice operating the machine with the StandOn attached on large, open, level terrain with no obstacles present before use. The StandOn will affect the machine operation, especially on slopes, when turning, and when stopping.
4. Ensure the pull arm assembly is securely connected to the pull frame.
5. *For Metro HP units:* Wheel drive belt tension may need adjustment. Refer to the machine Operator's Manual for adjustment instructions.
6. For operation of StandOn with Metro HP, Viking Hydro, and Turf Tracer HP on hilly terrain, front weight kit accessory, P/N 103-2637, is recommended.
7. For Operator's over 250 lbs, it is recommended to use pneumatic tire assembly, P/N 103-3798.

4.2 MOWING

⚠ DANGER ⚠	
POTENTIAL HAZARD	
<ul style="list-style-type: none"> ◆ If the StandOn rotates beyond 90°, there is a potential crushing hazard. 	
WHAT CAN HAPPEN	
<ul style="list-style-type: none"> ◆ Rapid rotation beyond 90° can cause the StandOn to jackknife into the mower engine deck and cause serious injury. 	
HOW TO AVOID THE HAZARD	
<ul style="list-style-type: none"> ◆ Dismount the StandOn and place in transport position before operating in reverse. ◆ Reduce speed when making sharp turns and operating on slopes. 	

1. Use care when turning to ensure that you do not swing yourself and the sulky into obstacles.
2. When turning, lean forward and toward the direction of the turn to help in keeping balance.

4.3 TRANSPORTING

Place the StandOn in the transport position when loading a unit on a trailer, unloading a unit from a trailer, or operating in reverse. See figure 9.

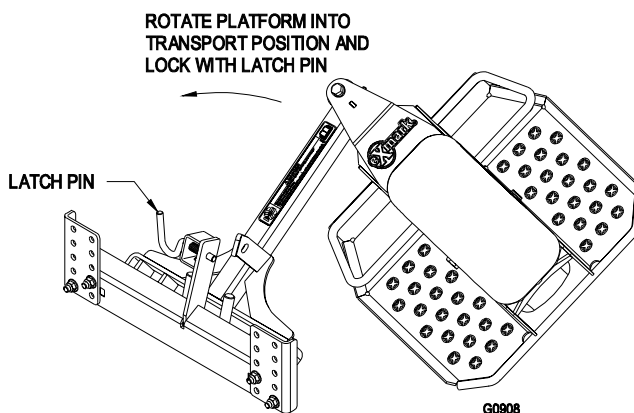

FIGURE 9

5. MAINTENANCE

IMPORTANT: Stop engine and wait for all moving parts to stop. Remove ignition key or spark plug wire(s) before performing any maintenance to the unit or StandOn.

Recommended Maintenance Schedule

Service Interval	Maintenance Procedure
Daily	<ul style="list-style-type: none"> • Visually inspect the StandOn assembly for any loose hardware or any other possible problem. Tighten hardware or correct problem before operating
Yearly	<ul style="list-style-type: none"> • Grease the pull arm pivot. • Grease front caster wheel hubs. See Section 5.1 for special lubrication instructions.

5.1 Lubricate caster wheel hubs:

- a) Stop engine, wait for all moving parts to stop, and remove key.
- b) Remove caster wheel from sulky frame.
- c) Remove seal guards from the wheel hub.
- d) Remove one of the spacer nuts from the axle assembly in the caster wheel. Note that thread locking adhesive has been applied to lock the spacer nuts to the axle. Remove the axle (with the other spacer nut still assembled to it) from the wheel assembly.
- e) Pry out seals, and inspect bearings for wear or damage and replace if necessary.
- f) Pack the bearings with a NGLI grade #1 multi-purpose grease.
- g) Insert (1) bearing, (1) new seal into the wheel.
NOTE: Seals (Exmark PN 103-0063) must be replaced.
- h) If the axle assembly has had both spacer nuts removed (or broken loose), apply a thread locking adhesive to (1) spacer nut and thread onto the axle with the wrench flats facing outward. Do not thread spacer nut all of the way onto the end of the axle. Leave approximately 1/8" (3 mm) from the outer surface of the spacer nut to the end of the axle inside the nut.
- i) Insert the assembled nut and axle into the wheel on the side of the wheel with the new seal and bearing.
- j) With the open end of the wheel facing up, fill the area inside the wheel around the axle full of NGLI grade #1 multi-purpose grease.
- k) Insert the second bearing and new seal into the wheel.
- l) Apply a thread locking adhesive to the 2nd spacer nut and thread onto the axle with the wrench flats facing outward.
- m) Torque the nut to 75-80 in-lbs. (8-9 N-m), loosen, then re-torque to 20-25 in-lbs. (2-3 N-m). Make sure axle does not extend beyond either nut.
- n) Re-install the seal guards over the wheel hub and insert wheel into the sulky frame. Re-install caster bolt and tighten nut fully.

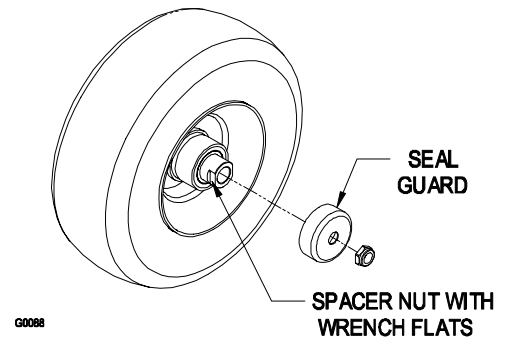

FIGURE 10

IMPORTANT: To prevent seal and bearing damage, check the bearing adjustment often. Spin the caster tire. The tire should not spin freely (more than 1 or 2 revolutions) or have any side play. If the wheel spins freely, adjust torque on spacer nut until there is a slight amount of drag. Re-apply threadlocking adhesive.

6. ADJUSTMENTS

IMPORTANT: Stop engine and wait for all moving parts to stop. Remove ignition key or spark plug wire(s) before making any adjustments to the unit or StandOn.

6.1. Mounting Bracket and Tire Adjustment.

To obtain a horizontal pull arm, the mounting brackets and the platform wheel can be repositioned. See Figure 11.

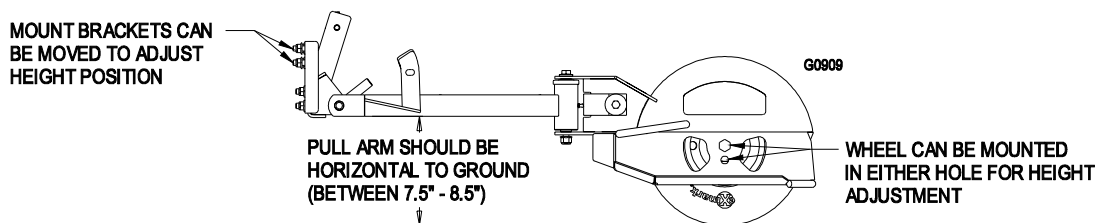
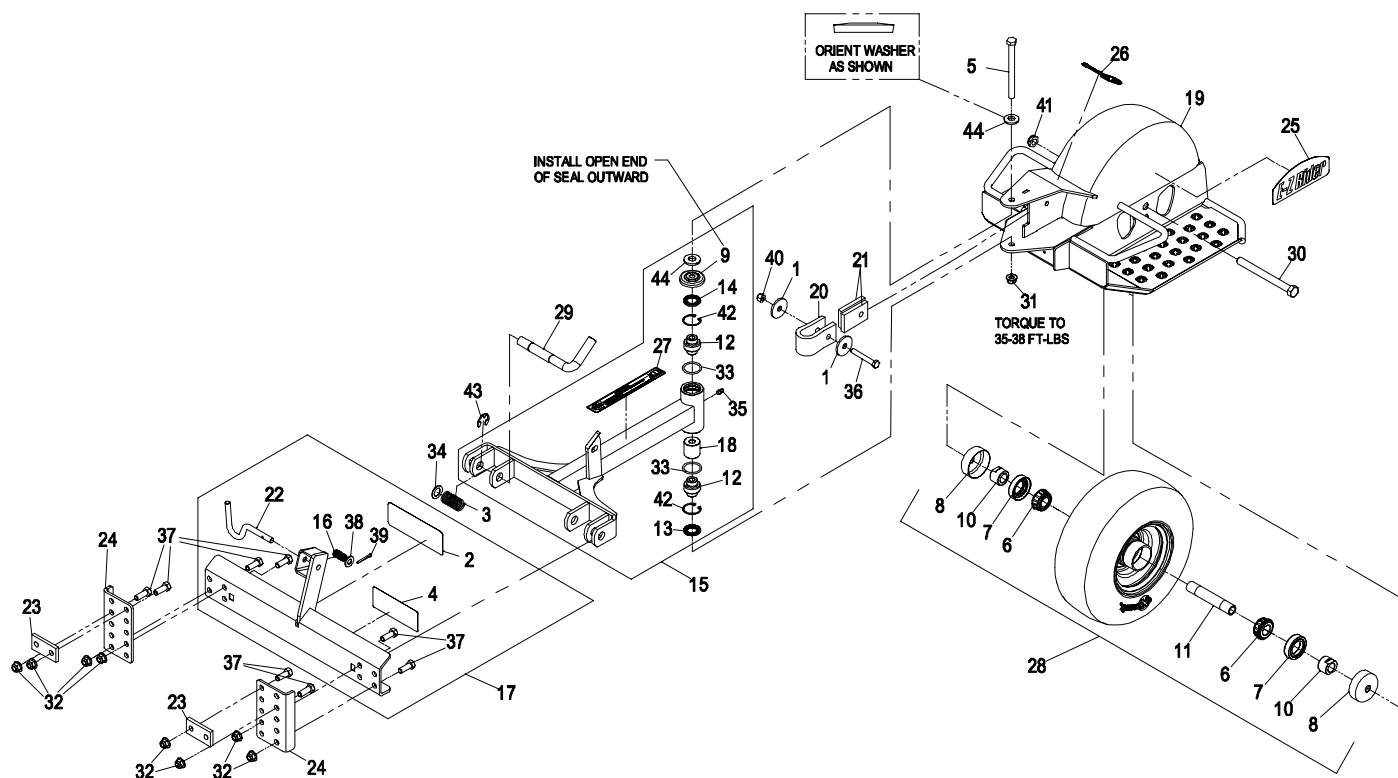

FIGURE 11

NOTE: To achieve more ground clearance for higher cutting heights, raise the platform by using the lower wheel adjustment hole and corresponding mounting bracket holes.

7. PARTS LIST



Item	Part No.	Description	Qty.
1	1-213069	Washer, Special	2
2▲	1-303517	Decal, Belt Drive.....	2
3	1-373054	Spring, Hitch Release.....	2
4▲	1-403143	Decal, Sulky Warning	2
5	323-38	Screw, HH 3/8-16 x 4 3/4.....	1
6	1-633585	Bearing, Cone Tapered	2
7	103-0063	Seal, Double Lip	2
8	103-2768	Guard, Seal	2
9	103-2916	Guard, Top	1
10	103-3051	Spacer, Nut	2
11	103-3157	Axle, Caster.....	1
12	103-3504	Bearing, Spherical	2
13	103-3505	Seal, Double Lip	1
14	103-3506	Seal, Single Lip	1
15◇	103-9589	Kit, Pull Arm W/Brgs & Decal	1
16	103-6643	Spring, Lock Pin	1
17■	103-6646	Asm, Frame Pull W/Decals	1
18	103-1361	Spacer, Hydro Control LH.....	1
19	103-9590	Asm, Sulky Frame W/Decals.....	1
20	103-6652	Stop, Rotation.....	1
21	103-6654	Pad, Stop	2
22	103-6656	Pin, Latch	1

Item	Part No.	Description	Qty.
23	103-6663	Plate, Back-Up	2
24	103-6675-01	Plate, Adapter	2
25	109-1117	Decal.....	2
26	103-8845	Decal, Exmark.....	1
27	103-9141	Decal, Sulky	1
28●+	103-9591	Asm, Caster Wheel	1
29	103-9169	Pin, Lift Arm	2
30	103-9508	Screw, HH 1/2-13 X 5 1/4.....	1
31	32128-21	Nut, Hex Flg-Side Lock 3/8-16	1
32	104-8301	Nut, Nyloc 3/8-16 Flg.....	8
33	106-7159	O-Ring.....	2
34	107-3041	Washer	2
35	302-19	Zerk, 1/4-28 Str	1
36	322-11	Screw, HH 5/16-18 X 2 1/4.....	1
37	323-7	Screw, HH 3/8-16 X 1 1/4.....	8
38	3256-24	Washer, 3/8 SAE	1
39	3272-11	Pin, Cotter 1/8 X 1	1
40	3296-29	Nut, Nyloc 5/16-18	1
41	3296-45	Nut, Nyloc 1/2-13	1
42	32120-10	Ring, Retaining.....	2
43	32120-19	E-Ring.....	2
44	98-5975	Washer, Spring Disk 3/8	1

- Does not include screw item # 37.
- Includes screw item #30 and nut item #41.
- ▲ One of each decal is shipped loose to be placed on Turf Tracer and Viking Hydro mowers only.
- ◇ Includes items 5, 31, & 44.
- ⊕ For Operator's over 250 lbs, it is recommended to use pneumatic tire assembly, P/N 103-3798.

8.

**2-Year Limited Warranty
Exmark Turf Equipment**

(For units purchased on or after October 1, 2004)

Conditions and Products Covered

Exmark Mfg. Co. Inc. and its affiliate, Exmark Warranty Company, pursuant to an agreement between them, jointly warrant on the terms and conditions herein, that we will repair, replace or adjust any part manufactured by Exmark and found by us (in the exercise of our reasonable discretion) to be defective in factory materials or workmanship for a period of two years.

This warranty applies to Exmark turf equipment purchased on or after October 1, 2004 sold in the US or Canada. This warranty may only be assigned or transferred to a second (or third) owner by an authorized Exmark dealer. The warranty period commences upon the date of the original retail purchase.

<u>Products</u>	<u>Warranty Period</u>
• All Products (except as noted below)	2 years
• All Attachments and Accessories	1 year
• Metro 21 and Metro 26 Series	1 year
• Belts and Tires	90 days
• Battery	1 Year Prorated
• Engine*	Warranty is covered by engine manufacturer

*Please refer to the engine manufacturer's warranty statement that is included in the literature packet. We are not authorized to handle warranty adjustments on engines.

This warranty only includes the cost of parts and labor.

Items and Conditions Not Covered

This warranty does not cover the following:

- Pickup and delivery charges to and from any authorized Exmark Service Dealer.
- Any damage or deterioration due to normal use, wear and tear, or exposure.
- Cost of regular maintenance service or parts, such as filters, fuel, lubricants, tune-up parts, and adjustments.
- Any product or part which has been altered or misused or required replacement or repair due to normal wear, accidents, or lack of proper maintenance.
- Any repairs necessary due to use of parts, accessories or supplies, including gasoline, oil or lubricants, incompatible with the turf equipment or other than as recommended in the operator's manual or other operational instructions provided by Exmark.

All warranty work must be performed by an authorized Exmark Service Dealer using Exmark approved replacement parts.

Instructions for Obtaining Warranty Service

1. Contact any Exmark Service Dealer to arrange service at their dealership. To locate a dealer convenient to you, access our website at www.exmark.com. U.S. Customers may also call 402-223-6375.
2. Bring the product and your proof of purchase (sales receipt) to the Exmark Service Dealer.

If for any reason you are dissatisfied with the Service Dealer's analysis or with the assistance provided, contact us at:

Exmark Customer Service Department
The Exmark Warranty Company
2101 Ashland Avenue
Beatrice, NE 68310
402-223-6375 or
service@exmark.com

Owner's Responsibilities

The Exmark turf equipment, including any defective part, must be returned to an authorized Exmark service dealer within the warranty period. This warranty extends only to turf equipment operated under normal conditions. You must properly service and maintain your Exmark product as described in the operator's manual. Such routine maintenance, whether performed by a dealer or by you, is at your expense.

As a condition to this warranty, customer shall have read the operator's manual and shall have completed and submitted to Exmark Warranty Company, within the prescribed time, the Exmark warranty registration.

General Conditions

The sole liability of Exmark and Exmark Warranty Company with respect to this warranty shall be repair and replacement as set forth herein. **Neither Exmark nor Exmark Warranty Company shall have any liability for any other cost, loss or damage, including but not limited to, any incidental or consequential loss or damage.**

In particular, we shall have no liability or responsibility for:

- Expenses related to gasoline, oil or lubricants.
- Travel time, overtime, after hours time or other extraordinary repair charges or charge relating to repairs or replacements outside of normal business hours at the place of business of the authorized Exmark service dealer.
- Rental of like or similar replacement equipment during the period of any warranty, repair or replacement work.
- Any telephone or telegram charges or travel charges.
- Loss or damage to person or property other than that covered by the terms of this warranty.
- Any claims for lost revenue, lost profit or additional cost as a result of a claim of breach of warranty.
- Attorney's fees.

No Claim of breach of warranty shall be cause for cancellation or rescission of the contract of sale of any Exmark mower.

There are no understandings, agreements, representations, or warranties, express or implied, including but not limited to any regarding the merchantability (that product is fit for ordinary use) or fitness for use (that product is fit for a particular purpose), not specified herein, respecting the equipment which is the subject of this warranty.

Some states do not allow exclusions of incidental or consequential damages, or limitations on how long an implied warranty lasts, so the above exclusions and limitations may not apply to you.

This warranty gives you specific legal rights, and you may also have other rights which vary from state to state.

NOTES

NOTES

SEE EXMARK'S COMPLETE LINE OF ACCESSORIES

RIDING ACCESSORIES

CUSTOM RIDE SEAT SUSPENSION SYSTEM
DECK LIFT ASSIST KIT
HITCH KIT
LIGHT KIT
MICRO-MULCH SYSTEM
ROLL OVER PROTECTION SYSTEM (ROPS)
SNOW BLADE
SUN SHADE
TRASH CONTAINER
TURF STRIPER
ULTRA VAC COLLECTION SYSTEM
ULTRA VAC QUICK DISPOSAL SYSTEM

WALK BEHIND ACCESSORIES

GRASS CATCHER
MICRO-MULCH SYSTEM
STEERABLE SULKY
SULKY HITCH KIT
TURF STRIPER
STANDON

Check us out on the Web:

www.exmark.com

© 2004-2006
EXMARK MFG. CO. INC.
INDUSTRIAL PARK BOX 808
BEATRICE, NE 68310
ALL RIGHTS RESERVED

PART NO. 109-5262 Rev A.
(402) 223-6300
FAX (402) 223-5489
PRINTED IN U.S.A.

