

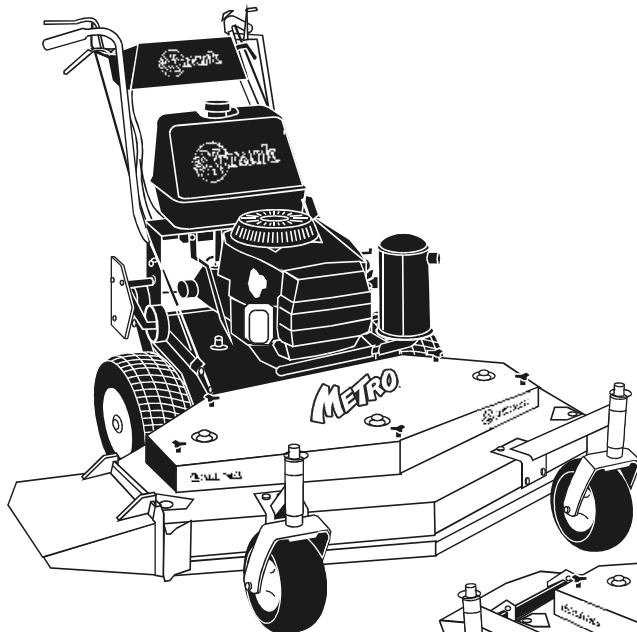

For Serial Nos.
670,000 & Higher

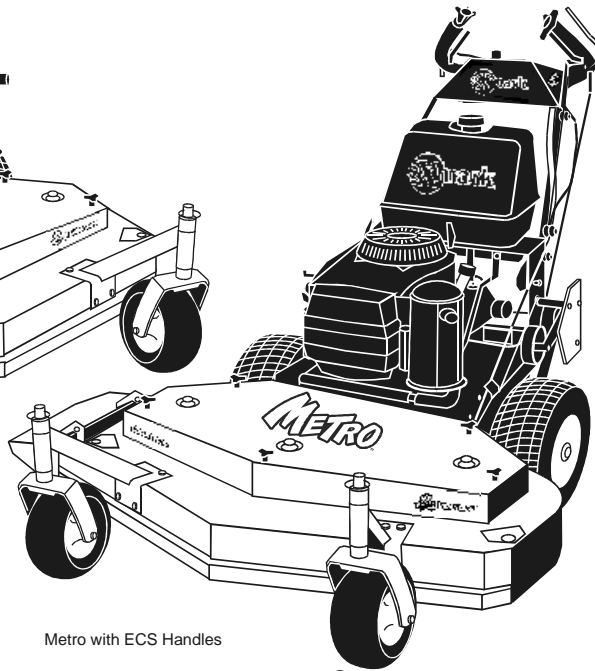

Metro with Pistol Grip Handles



Metro with ECS Handles

PARTS MANUAL

METRO[®]

CONGRATULATIONS on the purchase of your new Exmark mower. This product has been carefully designed and manufactured to give you a maximum amount of dependability and years of trouble-free operation. If additional information is needed, or should you require trained mechanic service, contact your authorized Exmark equipment dealer or distributor. If you need to order replacement parts from your dealer, always give the model number and serial number of your mower as well as the part number, description and quantity of the part needed.

The Serial No. plate is located on the top front engine frame on the right hand side of the machine. For ease of ordering and reference, we suggest that you record the information requested in the following identification table.

Place Model No. and Serial No. Label Here (Included in Literature Pack) or Fill in Below
Model No. _____
Serial No. _____

Engine Model No. and Spec. No. (Code) _____

Engine Serial No. (E/No) _____

Date Purchased _____

EXMARK PARTS PLUS® PROGRAM

EFFECTIVE DATE: September 1, 1995

Program

If your Exmark dealer does not have the Exmark part in stock, Exmark will get the parts to the dealer the next business day or the part will be FREE* Guaranteed!!

How the Program Works

1. If dealer does not have part in stock for a "down" unit at the time of request by customer, the dealer contacts his distributor by 1:00 p.m., local time, and requests Exmark Parts Plus® shipment of six (6) line items or less.
2. Distributor ships part(s) to dealer or customer, as requested by dealer, same day, overnight UPS. Distributor bills dealer for part and freight charges where applicable.
3. If distributor does not have the part(s) in stock to satisfy Exmark Parts Plus® order, he contacts Exmark by 3:00 p.m., central time, with an Exmark Parts Plus® order of six (6) line items or less.
4. If order is received by 3:00 p.m. central time, Exmark ships part(s) direct to dealer or customer, as requested by distributor, same day, overnight UPS. Exmark bills the distributor for parts and shipping charges, where applicable.
5. The customer pays for the part and freight if it is shipped under the Exmark Parts Plus® and if it arrive in accordance to the program.
6. Who pays for the part and freight if it fails to arrive overnight in accordance to the program?
 - A. Under any circumstance the customer does not pay.
 - B. If the part does not arrive overnight due to:
 1. The dealer not submitting the Exmark Parts Plus® order to his Exmark distributor by 1:00 p.m., the dealer pays for the part and freight.
 2. The Distributor being unable to ship the part the same day or not submitting the Exmark Parts Plus® order to Exmark by 3:00 p.m., central time, the Distributor pays for the part and freight.
 3. Exmark being unable to ship the part and the Exmark parts order is received by 3:00 p.m., central time, Exmark pays for the part and freight.
 4. If the part does not arrive overnight due to the shipper (UPS), the shipper pays for the freight and Exmark pays for the part.

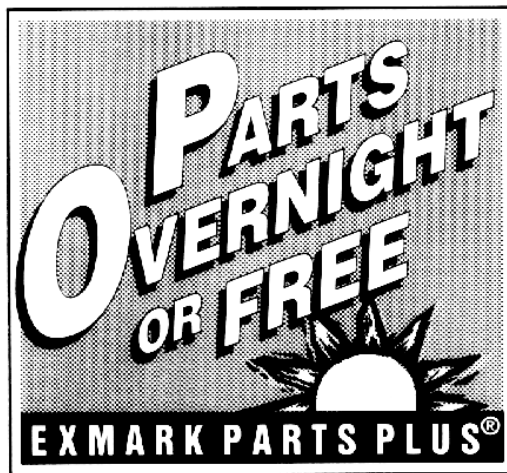

The following restrictions apply -- The Exmark Parts Plus® Program is available only through participating Exmark Dealers and applies only to orders submitted on this program Monday through Thursday. Parts Plus service is available only in the 48 contiguous United States. UPS has initiated a Saturday delivery program to many areas of the continental United States and can be requested for an overnight shipment on Friday to be delivered Saturday. The next day air charge, plus the Saturday delivery fee will be the responsibility of the purchaser. Exmark Mfg. will assume no responsibility for Saturday delivery shipments. To qualify, all Exmark Parts Plus® orders must be received by Exmark by 3:00 p.m., central time. Orders must be six (6) line items or less. Exclusions from the Exmark Parts Plus® Program are: Any wholegood or accessory in its entirety, engines and engine replacement parts, 5-speed Peerless transmissions and 5-speed transaxles, hydraulic or hydrostatic wheel motors, cutter decks and engine decks or any item exceeding United Parcel Service size and weight restrictions.

Due to UPS restrictions, aerosol spray paint is considered a hazardous material and cannot be shipped via UPS next day or Second Day Air.

Exmark Manufacturing stocks a limited supply of parts for transaxles, pumps and wheel motors. These parts can be ordered for Next Day Air shipment but will not be guaranteed per the Parts Plus Program.



**READ OPERATOR'S MANUAL BEFORE
OPERATING OR SERVICING EXMARK EQUIPMENT.**

TABLE OF CONTENTS

<u>Description</u>	<u>Page</u>
32" and 36" Mower Deck	3-4
48" Mower Deck	5-6
Decals.....	15
Engine Deck Group.....	7-10
Upper Handles & Controls, ECS	13-14
Upper Handles & Controls, Pistol Grip	11-12
Wiring Diagram	16

32" and 36" MOWER DECK

Item	Part No.	Description	Qty.
1	103-2312	Deck (103-2307-01) W/Decals & Dogleg(36")	1
	103-2313	Deck (103-2301-01) W/Decals & Dogleg (32")	1
2	1-302189-01	Wld, Dogleg Baffle	1
3	322-2	Screw, HH 5/16-18 x 5/8	7
4	32128-20	Nut, Whizlock 5/16-18	22
5	103-3600	Asm, Engagement Arm W/Bushings	1
6	302-52	Zerk, 1/8 NPT Straight	2
7	302-19	Zerk, 1/4-28 Straight	1
8	1-323385	Knob, Belt Cover	4
9	1-809020	Quick Pin, 10" Caster	2
10	3296-29	Nut, Nyloc 5/16-18	3
11	323-8	Screw, HH 3/8-16 x 1 1/2	8
12	3290-357	Nut, Whizlock 3/8-16	16
13	1-323748	Ring, Push-On 7/16	1
14	98-5975	Washer, Spring Disk 3/8	9
15	1-808280	Pin, Clevis 5/16 x 1	1
16	1-303105	Yoke	1
17	1-806003	Hairpin, Cotter #2	3
18	32151-103	E-Ring	1
19	702809	Screw, HH 3/8-16 x 1 7/8	1
20	103-6584	Blade, Notched (36")	2
●	103-6582	Blade, Mulching (36")	2
	103-6580	Blade, Low Lift (36")	2
	103-1578	Blade, Solid (36")	2
	103-6337	Blade, Extreme (36")	2
	103-6583	Blade, Notched (32")	2
●	103-6581	Blade, Mulching (32)	2
	103-2507	Blade, Low Lift (32")	2
	103-1577	Blade, Solid (32")	2
	103-6336	Blade, Extreme (32")	2
21	1-513338	Washer, Special	2
22	3253-7	Washer, Lock 1/2	2
23	3217-9	Nut, Hex 1/2-13	2
24	325-20	Screw, HH 1/2-13 x 6	2
25	1-303352	Washer, Spindle	1
26	32120-35	E-Ring	1
27	1-323733	Drive Belt (To Blades) 36" Model	1
	1-323734	Drive Belt (To Blades) 32" Model	1
28◆	1-803310	Setscrew, 5/16-18 x 3/8	2
29	322-6	Screw, HH 5/16-18 x 1 1/4	9
30	3256-23	Washer, 5/16 SAE	1
31	1-303537	Stud, Belt Shield (Short)	2
32	1-303536	Stud, Belt Shield (Long)	2
33	1-324208	Shield (1-302213-01) W/Decals, 36"	1
	1-324194	Shield (1-322149-01) W/Decals, 32"	1
34	1-323417	Washer, Belt Cover Mount	4
35	1-322145-01	Wld, Caster Fork	2
36	103-1236	Asm, Caster Wheel Assembly	2

Item	Part No.	Description	Qty.
37	1-302233-01	Chute	1
38	3296-56	Nut, Nyloc 1/4-20 Thin	1
39	1-323729	Bearing	2
40	323-4	Screw, HH 3/8-16 x 3/4	8
41	1-603843	Pulley, Idler	1
42	103-8387	Asm, Cutter Housing Complete	2
43	322-5	Screw, HH 5/16-18 x 1	2
44+	103-8280	Asm, Cutter Housing	2
45	302-61	Zerk, 45° 1/4-28	2
46	103-2535	Spacer	2
47	1-403179	Tube, Pivot	1
48	1-303314	Spacer, 10" Caster	8
49+	1-323529	Tube, Spindle	2
50	321-4	Screw, HH 1/4-20 x 3/4	2
51	1-303514	Flange, Thrust Bearing	4
52	1-323339	Washer	2
53+	1-403183	Sheave, Blade Driven	2
54	3219-6	Nut, Hex 5/8-18 UNF	2
55	1-800861	Screw, HH 5/8-18 x 8	2
56	1-807267	Key, 1/4 x 3/16 x 1 1/4	2
57	1-323539	Spacer, Blade Drive	8
58	1-513208	Washer, Spring Disc 5/8	2
59	1-303434	Bushing, Engagement	1
60	1-303348	Eye Bolt (Left Hand Thread)	1
61	1-303236	Turnbuckle Body	1
62	1-303238	Eye Bolt (Right Hand Thread)	1
63	1-322235	Arm, Assist	1
64	322-10	Screw, HH 5/16-18 x 2	1
65	1-323303	Linkage, Assist Arm	1
66◇	103-1238	Asm, Caster/Mount Complete	2
▲	103-2281	Asm, Caster/Mnt Complete, Weighted	2
67◇	1-302203	Asm, Caster Whl Support W/Bearings	2
▲	103-2296	Asm, Caster Wheel Support W/Bearings, Weighted	2
68◇	1-302194-01	Wld, Caster Wheel Support	2
▲	103-2297-01	Wld, Caster Wheel Support, Weighted	2
69	1-303334	Washer, Spring Disc 5/16	9
70	1-324372	Asm, Pad/Spring	1
71+	103-1330	Guard, Bearing Top	2
72	3256-3	Washer, 5/16 Std	1
73	1-323715	Rod, Brake 36"	1
	1-323718	Rod, Brake 32"	1
74	1-323071	Spring	1
75	1-323747	Spring, Compression	1
76	1-323746	Spacer, Flanged	1
77	3296-42	Nut, Nyloc 1/4-20	2
78	1-513547	Spacer, Front Caster	2
79	103-2171	Kit, Tire & Wheel Asm W/ Spacer	2
80	1-513809	Roller Bearing	1
81	1-513810	Bushing	4

Exmark red touch up paint (spray paint - P/N 1-850337 - .6 oz liquid bottle - P/N 103-9140).

- ◆ Use Pro-lock Nut Type (p/n 1-840022 .5 ml tube) on the setscrews.
- Requires installation of Micro-Mulch accessory for proper mulching. Mulch kit P/N's MK322(32") or MK362(36")
- ◆ Models with ECS handles only.
- ◇ Models with Standard pistol grip handles only.
- + Apply Mobil HTS grease (P/N 103-5217 1.5 oz packet) (or a food-grade anti-sieze) between the spindles & bearings and spindles & sheaves and under top bearing guard. DO NOT use a copper or nickel based anti-sieze.

32" & 36" MOWER DECK

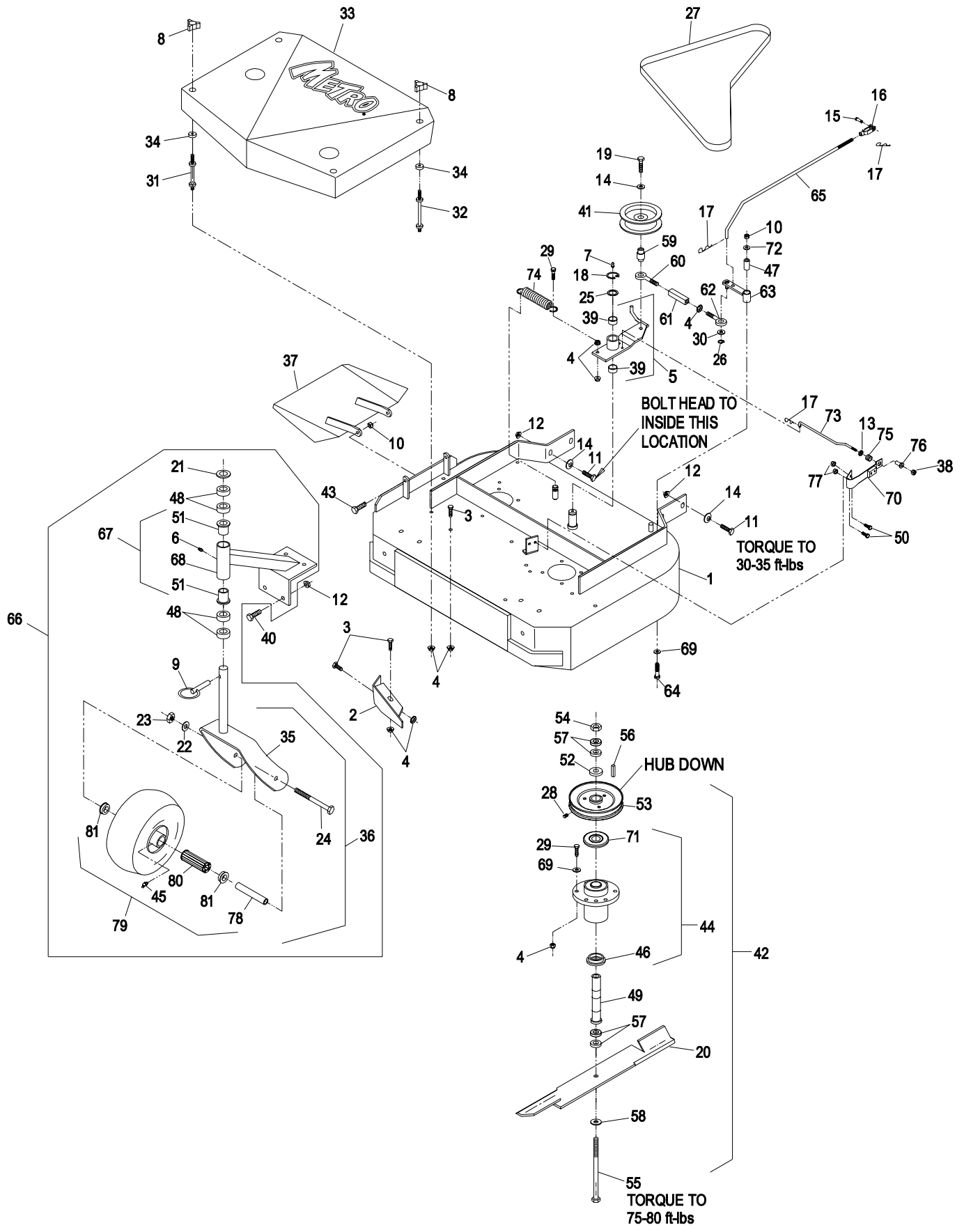

48" MOWER DECK

Item	Part No.	Description	Qty.
1	109-2601	Deck (103-9818-01)W/Dcls & Dogleg.....	1
2	1-402107-01	Wld, Dogleg Baffle	1
3	322-2	Screw, HH 5/16-18 x 5/8	4
4	32128-20	Nut, Whizlock 5/16-18	12
5	3296-29	Nut, Nyloc 5/16-18	3
6	323-7	Screw, HH 3/8-16 x 1 1/4 HH	18
7	3290-357	Nut, Whizlock 3/8-16	19
8	98-5975	Washer, Spring Disk 3/8.....	12
9	1-808280	Pin, Clevis 5/16 x 1	1
10	1-303105	Yoke	1
11	1-613098	Pulley, Idler Pulley.....	1
12	32151-103	E-Ring.....	1
13	103-6583	Blade, Notched (48").....	3
●	103-6581	Blade, Mulching (48").....	3
	103-2507	Blade, Low Lift (48").....	3
	103-1577	Blade, Solid (48")	3
	103-6336	Blade, Extreme (48").....	3
14	1-323303	Linkage, Assist Arm	1
15◆	1-803310	Setscrew, 5/16-18 x 3/8.....	3
16	323-13	Screw, HH 3/8-16 x 2 3/4	2
17	3296-42	Nut, Nyloc 1/4-20	2
18	1-403186	Pully, Idler.....	1
19	103-8387	Asm, Cutter Housing Complete.....	3
20+	103-8280	Asm, Cutter Housing.....	3
21	302-61	Zerk, 45° 1/4-28	2
22	103-2535	Spacer	3
23	1-513809	Bearing, Roller	2
24	702809	Screw, HH 3/8-16 x 1 7/8	1
25+	1-323529	Tube, Spindle.....	3
26	32120-35	E-Ring.....	1
27	3296-39	Nut, Nyloc 3/8-16	18
28	1-807267	Key, 1/4 x 3/16 x 1 1/4	3
29+	1-403183	Sheave, Blade Driven	3
30	1-513208	Washer Spring Disk 5/8.....	3
31	1-800861	Screw, HH 5/8-18 x 8	3
32	1-323539	Spacer, Blade Drive	12
33	1-323339	Washer	3
34	1-322235	Arm, Assist.....	1
35	3219-6	Nut, Hex 5/8-18 UNF.....	3
36	1-303434	Bushing, Engagement.....	1
37	1-303348	Eye Bolt (Left Hand Thread).....	1
38	1-303236	Turnbuckle Body	1
39	1-303238	Eye Bolt (Right Hand Thread)	1
40	1-323747	Spring, Compression.....	1
41	1-806003	Hairpin, Cotter #2.....	3
42	1-303352	Washer, Spindle.....	1
43	322-10	Screw, HH 5/16-18 x 2	1
44	1-323729	Bearing	2
45	1-303334	Washer, Spring Disk 5/16.....	1

Item	Part No.	Description	Qty.
46	103-3600	Asm, Engagement Arm W/Bushings	1
47	322-6	Screw, HH 5/16-18 x 1 1/4	1
48	302-19	Zerk, 1/4-28 Str.....	1
49	3256-24	Washer, 3/8 SAE	2
50	323-20	Screw, HH 3/8-16 x 3 1/4.....	1
51	3296-56	Nut, Nyloc 1/4-20 Thin	1
52	1-402106-01	Wld, Chute.....	1
53	1-403179	Tube, Pivot	1
54	3256-3	Washer, Flat 5/16 Std	1
55	1-323714	Rod, Brake LH	1
56	1-324372	Asm, Pad/Spring.....	1
57	3256-23	Washer, 5/16 SAE	1
58	1-603843	Pulley, Idler.....	1
59	1-403174	Belt, Drive (Main Deck) 48"	1
60	1-323746	Spacer, Flanged	1
61	1-403184	Bushing	2
62	322-5	Screw, HH 5/16-18 x 1	2
63	1-323071	Spring	1
64+	103-1330	Guard, Bearing Top	3
65◇	103-1238	Asm, Caster/Mount Complete	2
▲	103-2281	Asm, Caster/Mnt Complete, Weighted ...	2
66◇	1-302203	Asm, Caster Whl Support W/Bearings ...	2
▲	103-2296	Caster Wheel Support W/Bearings, Weighted	2
67◇	1-302194-01	Wld, Caster Wheel Support.....	2
▲	103-2297-01	Wld, Caster Wheel Support, Weighted... 2	
68	302-52	Zerk, 1/8 NPT	2
69	1-303514	Flange, Thrust Bearing	4
70	1-303314	Spacer, 10" Caster.....	8
71	103-1236	Asm, Caster Wheel.....	2
72	1-322145-01	Wld, Caster Fork.....	2
73	321-4	Screw, HH 1/4-20 x 3/4.....	2
74	1-323748	Ring, Push-On 7/16	1
75	1-323417	Washer, Belt Cover Mount.....	5
76	323-4	Screw, HH 3/8-16 x 3/4	8
77	325-20	Screw, HH 1/2-13 x 6.....	2
78	3217-9	Nut, Hex 1/2-13.....	2
79	3253-7	Washer, Lock 1/2.....	2
80	1-513338	Washer, Special.....	2
81	1-809020	Quick Pin, 10" Caster.....	2
82	1-303537	Stud, Belt Shield (Short)	2
83	1-303536	Stud, Belt Shield (Long)	3
84	1-323385	Knob, Belt Cover.....	5
85	1-404238	Shield (1-402100-01)W/Decals 48"	1
86	1-403188	Spacer, Belt Guide.....	1
87	323-8	Screw, HH 3/8-16 x 1 1/2.....	8
88	1-513547	Spacer, Front Caster.....	2
89	103-2171	Kit, Tire & Wheel Asm W/ Spacer	2
90	1-513810	Bushing	4

Exmark red touch up paint (spray paint - P/N 1-850337 - .6 oz liquid bottle - P/N 103-9140).

- ◆ Use Pro-lock Nut Type (p/n 1-840022 .5 ml tube) on the setscrews.
- Requires installation of Micro-Mulch accessory for proper mulching. Mulch kit P/N's MK483.
- ▲ Models with ECS handles only.
- ◇ Models with Standard pistol grip handles only.
- ✚ Apply Mobil HTS grease (P/N 103-5217 1.5 oz packet) (or a food-grade anti-sieze) between the spindles & bearings and spindles & sheaves and under top bearing guard. DO NOT use a copper or nickel based anti-sieze.

48" MOWER DECK

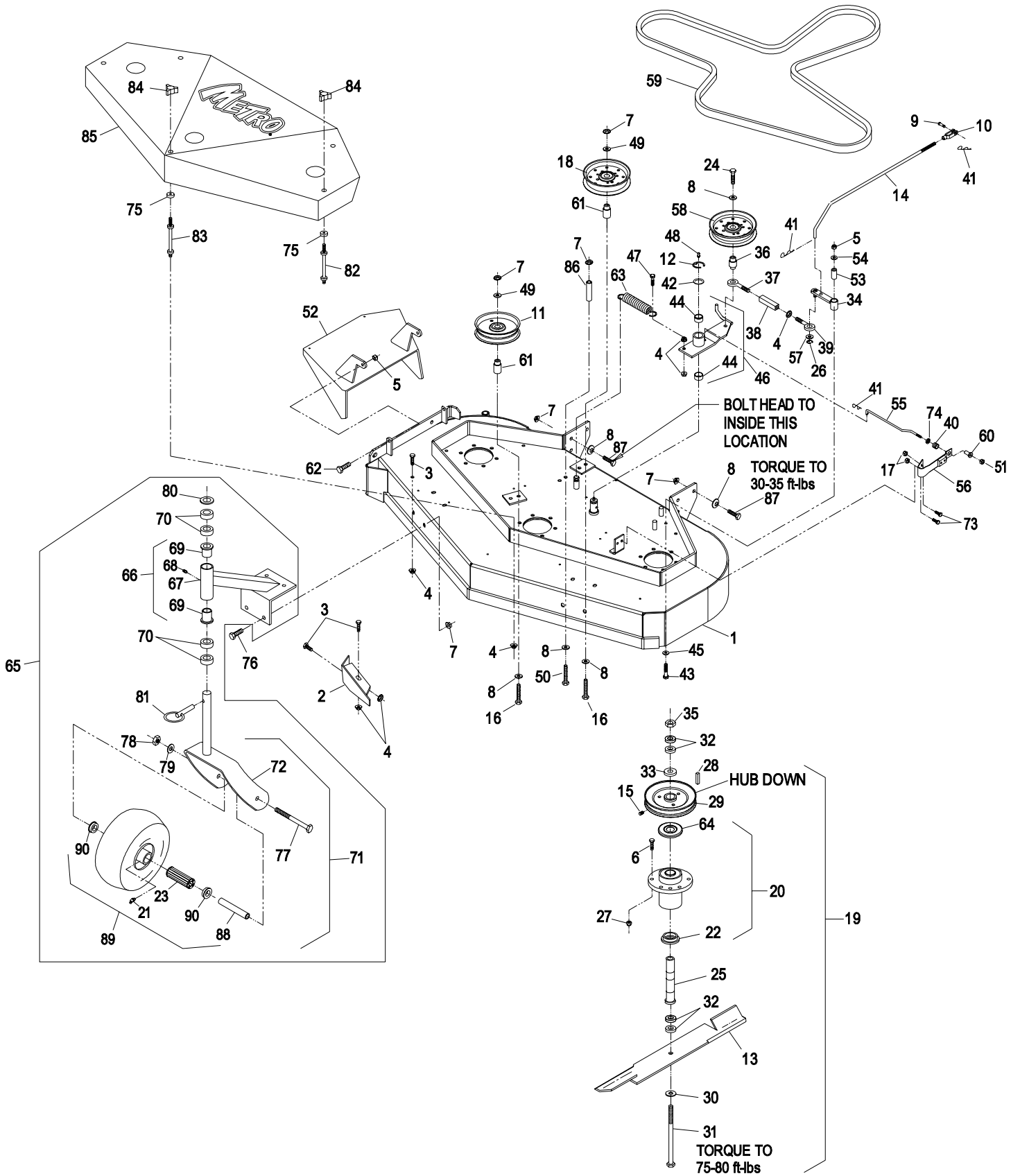

ENGINE DECK GROUP

Item	Part No.	Description	Qty.
1	103-3499	Rear Deck (103-9897-01) W/Decals.....	1
2	1-323500	Transmission.....	1
3	1-324340	Asm, Coupling, W/Guard And Zerk	2
4	1-323502	Shaft, Transmission Output.....	2
5	103-2587	Adapter, Oil Drain	1
6+	1-323252	Bearing, Transmission Shaft	2
7	1-323254	Flange, Bearing Transmission Shaft.....	2
8+	103-6511	Sheave, 3 1/4" (36"&48").....	2
+	103-6512	Sheave, 3 1/4" (32").....	2
9	32151-62	Ring, Retaining	2
10	1-805005	Washer, Lock 5/16 Heavy	4
11	1-373034	Washer, Flat	2
12◇	3245-41	Setscrew, 1/4-20 x 3/8 Cuppoint	2
13	1-323280	Belt, Transmission.....	1
14	3290-357	Nut, Whizlock 3/8-16.....	3
15	3296-39	Nut, Nyloc 3/8-16	1
16	103-3498	Shifter Plate (1-323387-03) W/Decals....	1
17	1-323389-03	Leg, Shifter Lever.....	2
18	3230-1	Bolt, Carriage 5/16-18 x 3/4	2
19	32128-20	Nut, Whizlock 5/16-18	2
20	51-4220	Coupler, Guard	2
21+	103-1666	Sheave, Trans. Drive, 2 3/4"	1
22+	103-1668	Sheave, Blade Drive (6.71")(36").....	1
+	103-1667	Sheave, Blade Drive(7.33")(32"&48")	1
23	5-1336	Key, 1/4 Sq x 2.....	1
24	1-303334	Washer , Spring Disk 5/16.....	4
25	32128-20	Nut, Whizlock 5/16-18	4
26	322-7	Screw, HH 5/16-18 x 1 1/2	4

Item	Part No.	Description	Qty.
27	323-13	Screw, HH 3/8-16x2 3/4.....	1
28◇	1-803310	Setscrew, 5/16-18 x 3/8 Cuppoint	2
29	1-633453	Spacer, Tube	1
30	1-603610	Washer, Spring Disk 7/16	2
31	9264964	Screw, HH 5/16-18 x 3/4 Tapping	4
32	1-303186	Crank, Bell.....	1
33+	1-323278	Sheave, Transmission Drive	1
34	1-323379	Washer, Shifter Lever	1
35	98-5975	Washer, Spring Disk, 3/8	1
36	3296-6	Nut, Nyloc 3/8-24	1
37	3257-5	Key, Woodruff 3/16 x 3/4	3
38	1-303282	Switch, Neutral.....	1
39	3231-6	Bolt, Carriage 3/8-16 x 2 SSN.....	1
40	3256-5	Washer , 7/16 Std.....	2
41	1-323285	Pulley, Transmission Drive.....	1
42	3256-24	Washer , 3/8 SAE	1
43	321-3	Screw, HH 1/4-20 x 5/8.....	4
44	3296-42	Nut, Nyloc 1/4-20	4
45	1-603403	Bolt, Shoulder 1/2 x 1.....	1
46◇	3212-6	Screw, HH ,7/16-20 x 1 1/2.....	1
47	1-513051	Switch, Blade Engagement.....	1
48	322-3	Screw, HH 5/16-18 x 3/4.....	4
49	3290-500	Screw, PPH #10-24 x 5/8.....	2
50	1-633181	Plate, Tapped	1
51	103-1606	Asm Shift Lever, W/Grip	1
52	103-1733	Grip	1
53	302-19	Zerk, 1/4-28 Str.....	2

Exmark red touch up paint (spray paint - P/N 1-850337 - .6 oz liquid bottle - P/N 103-9140).

Exmark black touch up spray paint – Gloss black

◇ Use Pro-lock (Nut type) Part No. 1-840022 (.5ml tube) on setscrew threads and on sheave retaining bolt in engine crankshaft.

+

Apply anti-seize compound to bore of blade drive and transmission drive sheaves on engine, drive sheave on transmission, and bearings and sheaves on transmission output shafts.

ENGINE DECK GROUP

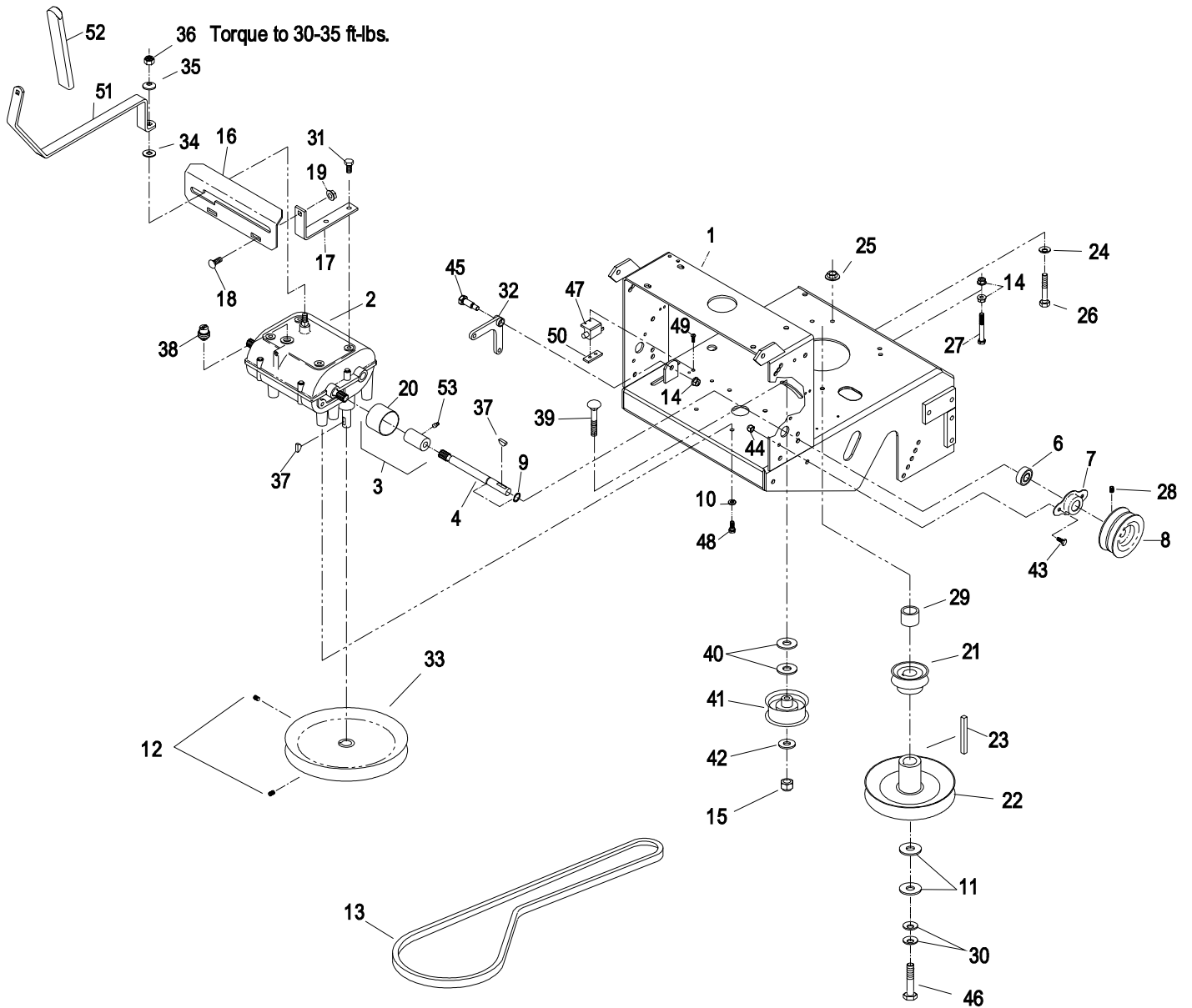

Oil Drain
Kawasaki Engines



5

ENGINE DECK GROUP (cont.)

Item	Part No.	Description	Qty.
1	103-1611-03	Wld, Brake Arm.....	2
2	302-19	Zerk, 1/4-28 Straight	4
3	1-322117-03	Wld, Axle (36" & 48" Models).....	1
	1-322141-03	Wld, Axle (32" Model).....	1
4	2412-104	Clip, Loom.....	2
5	103-1615-03	Wld, Idler Arm (LH)	1
6◇	1-806003	Hairpin, Cotter #2.....	4
■	1-806003	Hairpin, Cotter #2.....	2
7	103-1616-03	Wld, Idler Arm (RH).....	1
8■	32151-47	Klipring (For 3/8 Shaft)	6
◇	32151-47	Klipring (For 3/8 Shaft)	4
9	1-323288	Belt, Wheel Drive (36"&48" Models)	2
	1-323344	Belt, Wheel Drive (32" Model)	2
10	32128-20	Nut, Whizlock 5/16-18	4
11	1-323262	Band, Brake	2
12	110-5866	Wld, Brake Linkage Swivel.....	2
13	1-412358	Wld, Scraper (36"&48" Models).....	2
	1-603430	Scraper (32" Model)	2
14	3296-29	Nut, Nyloc 5/16-18	4
15	1-323277	Pulley, Idler (36"&48" Models).....	2
	1-323352	Pulley, Idler (32" Model)	2
16	322-6	Screw, HH 5/16-18 x 1 1/4	2
17	99-8664	Screw, HH 3/8-16 x 3 Tapping	2
18	3290-357	Nut, Whizlock 3/8-16.....	14
19	3296-39	Nut, Nyloc 3/8-16	4
20	1-323287-01	Shield, Wheel Drive.....	2
21	1-323283	Spacer	4
22	1-603402	Spring, Drive	2
23■	1-323548	Linkage, Brake	2
◇	103-1619	Linkage, Brake (LH)	1
◇	103-1620	Linkage, Brake (RH).....	2

Item	Part No.	Description	Qty.
24	1-513959	Wingnut, Nyloc 5/16-18.....	2
25	323-39	Screw, HH 5/8-16 x 5.....	4
26	1-523157	Spacer, Wheel (14 Ga.)	As Req'd.
	1-543436	Spacer, Wheel (18 Ga.)	As Req'd.
27	98-5975	Washer, Spring Disk 3/8	4
28	1-323307	Pin, Clevis 3/8.....	2
29	1-803051	Pushnut, 3/8	2
30■	103-1864	Swivel, Short Adjust.....	2
◇	103-1618	Swivel, Short Adjust.....	2
31	323-6	Screw, HH 3/8-16 x 1.....	4
32	109-4721	Asm, Wheel Drive (36"&48" Models)	2
	1-324193	Asm, Wheel Drive (32" Model)	2
33	1-323349	Sheave (32"Model)	2
34	109-4359	Asm, Drum & Sheave (36" & 48" Model) .	2
35	1-323261	Drum, Brake (32" Model)	2
36	1-323719	Asm, Wheel & Tire (36"&48"Models).....	2
	1-323346	Asm, Wheel & Tire (32"Model)	2
37	1-323720	Tire, 13 x 6.50-6 (4-Ply) (36"&48")	1
	1-323361	Tire, 13 x 5.00-6 (4-Ply) (32").....	1
38	1-323328	Asm, Wheel & Hub W/Brgs (36"&48")	1
	1-323360	Asm, Wheel & Hub W/Brgs (32").....	1
39	1-323329	Bearing, Flanged	4
40	322-5	Screw, HH 5/16-18 x 1	8
41	1-805005	Washer, Spring Disk 5/16	8
42	32120-47	E-Ring (For 1/2" Shaft).....	2
43■	1-323245	Spring, Compression	2
44	1-808519	E-Ring (For 1" Shaft)	2
45	1-373034	Washer, Swivel (32" Model Only).....	4
46■	3256-23	Washer, 5/16 SAE	4
47	98-3259	Shield, Trailing.....	1
48	322-3	Screw, HH 5/16-18 x 3/4.....	2

Exmark red touch up paint (spray paint - P/N 1-850337 - .6 oz liquid bottle - P/N 103-9140).

Exmark black touch up spray paint – Gloss black

◇ For units with ECS handles only.

■ For units with pistol grip handles only.

ENGINE DECK GROUP (cont.)

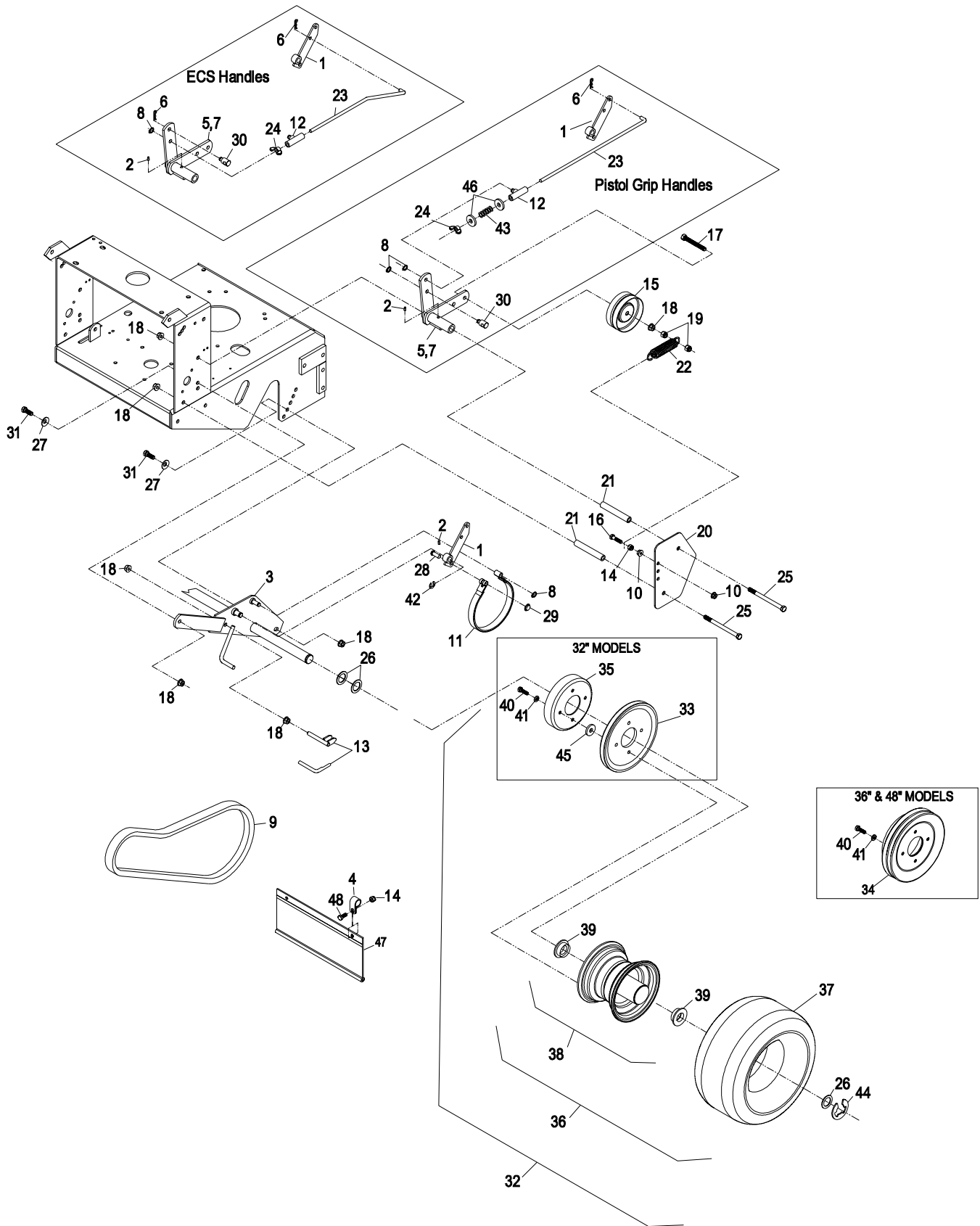

PISTOL GRIP UPPER HANDLES and CONTROLS

Item	Part No.	Description	Qty.
1	109-4695	Kit, Handle (109-4682-03) W/Decals	1
2	1-303097	Grip, Handle.....	2
3*	1-324279	Latch W/Grip (LH)	1
4	1-303019	Grip, Latch	2
5	1-302006	Drive Lever W/Grip.....	2
6	1-303021	Grip, Drive Lever.....	2
7	1-324280	Latch W/Grip (RH).....	1
8	1-323229	Clip, Loom 3/8.....	1
9	1-303435	Washer, Spring Disk 1/4.....	6
10	1-323359	Linkage, Wheel Drive	2
11	3296-42	Nut, Nyloc 1/4-20	3
12	3256-22	Washer, 1/4 SAE	1
13	321-18	Screw, HH 1/4-20 x 2 1/4	2
14	109-3958	Cable, Throttle	1
15	103-1797-01	Bracket, Choke Cable	1
16	1-303287	Tie, Plastic 5 1/2"	5
17	3296-39	Nut, Nyloc 3/8-16	5
18	3296-2	Nut, Nyloc 10-24	2
19	1-807513	Bolt, Carriage 10-24 x 1/2	2
20	1-806003	Cotter, Hairpin.....	4
21	1-808250	Pin, Clevis 3/16 x 1 3/4	2
22	1-803001	Palnut, 3/16.....	2
23	1-806340	Rollpin, 5/16 x 1	2
24	1-323549	Spacer	2
25●	1-412185-03	Lever, OPC (RH).....	1
26◇	1-803322	Setscrew, 5/16-24 x 5/16.....	2
27●	1-412183-03	Lever, OPC (LH)	1
28	323-6	Screw, HH 3/8-16 x 1	4
29	1-303365	Bushing, Nylon.....	2
30	1-322192-03	Rod, Connecting	1
31	1-403121	Switch, Key	1
	1-603511	Key, Ignition	1
	103-2106	Key, Exmark Logo	1
32	1-303363	Spring, Actuator	1
33	1-805004	Washer, Lock 1/4 Heavy	1
34	33114-016	Screw, HH M8-16 x 1.25	1

Item	Part No.	Description	Qty.
35	1-303088	Clip, Cable.....	1
36	1-303160	Spring, Compression	1
37	3256-23	Washer, 5/16 SAE	4
38	1-323298	Linkage, Blade Drive.....	1
39	1-322157	Engagmt. Lever, Blade W/Grip	1
40	1-303020	Grip, Lever.....	1
41	3256-4	Washer, 3/8 Std.....	2
42	323-10	Screw, HH 3/8-16 x 2.....	1
43	1-303335	Tie, Plastic Large	1
44	103-2893	Tank, Fuel W/Fitting.....	1
45	109-0346	Cap, Fuel Tank.....	1
46	1-808286	Pin, Clevis	2
47◇	103-2605	Fitting, Fuel Bulkhead W/Screen.....	1
48	103-0498	Nut, Ignition Switch	1
49	1-303077	Clamp, Fuel Line	4
50	321-4	Screw, HH 1/4-20 x 3/4.....	1
51	109-0306	Line, Fuel 6"	1
52	1-323430	Interlock, OPC.....	1
53	1-413510	Clip, Loom 1/2"	1
54	109-0293	Line, Fuel 8.5"	1
55	1-543296	Grommet	1
56	1-603770	Valve, Fuel	1
57	33113-016	Screw, HH M6-16 x 1	1
58	Kawasaki	PN 41019-1055 W/6" Fuel Line	1
59	321-3	Screw, HH1/4-20 x 5/8	2
60	103-1610	Harness, Wiring	1
61●	1-633023	Stud, Gas Tank.....	2
62	1-633349	Spring, Gas Tank.....	2
63	1-513051	Switch.....	1
64	1-633181	Plate, Tapped	1
65	3290-500	Screw, PPH #10-24 x 5/8.....	2
66	1-805005	Washer, Lock 5/16.....	2
67	3296-47	Nut, Nyloc 5/16-18.....	2
68	322-3	Screw, 5/16-18 x 3/4.....	2
69	32128-33	Nut, Whizlock 1/4-20	2
70	103-1796	Cable, Choke	1

NOTE: Use dielectric grease on all electrical connections.

Exmark black touch up spray paint – Gloss black

* Not illustrated.

◇ Use Pro-lock (Nut type) Part No. 1-840022 (.5 ml tube) on setscrew threads, and on fuel tank fitting.

● Use Pro-lock (Retaining) Part No. 1-840023 (.5 ml tube) on inside of bore of OPC hub and on fuel tank studs going into tank.

PISTOL GRIP UPPER HANDLES and CONTROLS

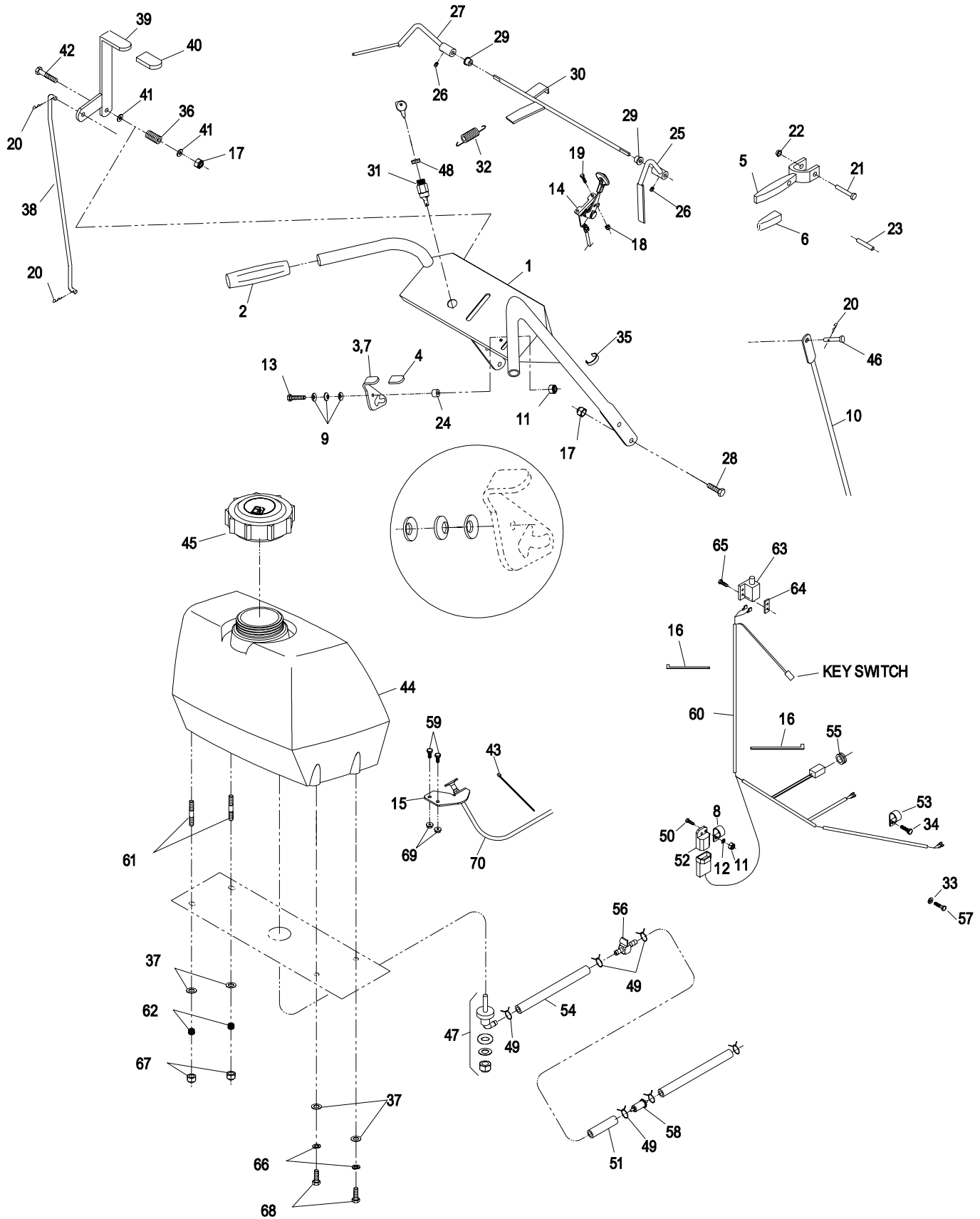

ECS UPPER HANDLES and CONTROLS

Item	Part No.	Description	Qty.
1◇	103-1566-03	Wld, Lever, OPC (LH)	1
2	1-303365	Bushing, Nylon.....	2
3◆	1-803322	Setscrew, 5/16-24 x 5/16.....	2
4	103-0769-03	Wld, OPC Rod	1
5	1-303363	Spring, Actuator	1
6	1-303335	Tie, Plastic 7 5/16"	1
7	1-807513	Bolt, Carriage 10-24 x 1/2	2
8	3296-2	Nut, Nyloc #10-24	2
9	109-3958	Cable, Throttle Control	1
10◇	103-1567-03	Wld, OPC Lever (RH).....	1
11	1-303020	Grip, Lever	1
12	103-1629	Lever, Clutch W/Grip.....	1
13	3296-29	Nut, Nyloc 5/16-18	2
14	3256-4	Washer, 3/8 Std	1
15	103-0027	Spacer	2
16	1-806003	Cotter, Hairpin.....	2
17	103-1627	Linkage, Upper.....	1
18	103-1604	Linkage, Wheel Drive	2
19	1-543296	Grommet.....	1
20	103-0815	Grip, Handle.....	2
21	1-303435	Washer, Spring Disk 1/4.....	6
22	103-1631	Latch, Thumb (LH) (Not Shown).....	1
	103-1630	Latch, Thumb (RH).....	1
23	3296-42	Nut, Nyloc 1/4-20	1
24	103-0770-03	Wld, Handle	1
25	1-303088	Clip, Cable	1
26	323-6	Screw, HH 3/8-16 x 1	4
27	109-0346	Cap, Fuel Tank	1
28	103-2893	Tank, Fuel W/Fitting.....	1
29◇	1-633023	Stud	2
30	1-633349	Spring, Fuel Tank.....	2
31	1-805005	Washer, Lock 5/16 Heavy	2
32	3296-47	Nut, Nyloc 5/16-18	2
33	322-3	Screw, HH 5/16-18 x 3/4	2
34◆	103-2605	Fitting, Fuel Bulkhead W/Screen	1
35	103-0498	Nut, Ignition Switch	1
36	1-303077	Clamp, Fuel Line	4
37	33114-016	Screw, HH M8-16 x1.25	1
38	1-603770	Valve, Fuel.....	1
39	1-805004	Washer, Lock 1/4 Heavy	1
40	Kawasaki	PN 41019-1055 W/6" Fuel Line.....	1

Item	Part No.	Description	Qty.
41	103-1610	Harness, Wiring.....	1
42	3256-22	Washer, 1/4 SAE	1
43	321-4	Screw, HH 1/4-20 x 3/4.....	1
44	1-403121	Switch, On/Off	1
	1-603511	Key, Ignition.....	1
	103-2106	Key, Exmark Logo	1
45	1-633181	Plate, Tapped.....	1
46	3296-39	Nut, Nyloc 3/8-16.....	5
47	3290-500	Screw, PPH #10-24 x 5/8.....	2
48	1-513051	Switch, Neutral Lockout	1
49	1-323229	Clip, Loom 3/8	1
50	1-303287	Tie, Plastic 5 1/2".....	6
51	1-323430	Module, Wiring Harness.....	1
52	323-14	Screw, HH 3/8-16 x 3.....	1
53	322-9	Screw, HH 5/16-18 x 1 3/4.....	2
54	1-413152	Bearing.....	4
55	103-2466-03	Lever, Drive (LH)	1
56	3219-3	Nut, Hex 3/8-24	2
57	321-14	Screw, HH 1/4-20 x 2 3/4.....	2
58	32128-33	Nut, Whizlock 1/4-20.....	12
59	103-0464	Pin, Spring 1/8 x 1/2	2
60	3256-22	Washer, 1/4 SAE	10
61◆	103-0235	Screw, 1/4-20 x 1 1/8 W/Nylon.....	2
62	103-2465-03	Lever, Drive (RH).....	1
63	3220-3	Nut, Jam 3/8-24	4
64	109-4934	Asm, Console (109-4649-03) W/Decals	1
65	3256-23	Washer, 5/16 SAE	4
66	321-3	Screw, HH 1/4-20 x 5/8.....	10
67	103-2513	Asm, Drive Lever (RH).....	1
	103-2514	Asm, Drive Lever (LH)	1
68	103-2463	Joint, .375 Ball End.....	2
69	103-0489-03	Bracket, OPC Axle.....	1
70	103-1796	Cable, Choke Push/Pull	1
71	103-1797-01	Bracket, Choke Cable.....	1
72	1-633080	Bushing	1
73	3256-14	Washer, #10 Std.....	1
74	109-0293	Hose, Fuel Line 8.5"	1
75	1-413510	Clip, Loom 1/2"	1
76	109-0306	Hose, Fuel Line 6"	1
77	33113-016	Screw, HH M6-16 x 1	1

NOTE: Use dielectric grease on all electrical connections.

Exmark black touch up spray paint – Gloss black

- ◆ Use Pro-lock (Nut type) Part No. 1-840022 (.5 ml tube) on setscrew threads, thumb latch screws and on fuel tank fitting.
- ◇ Use Pro-lock (Retaining) Part No. 1-840023 (.5 ml tube) on inside of bore of OPC hub and on fuel tank studs going into tank.

ECS UPPER HANDLES and CONTROLS

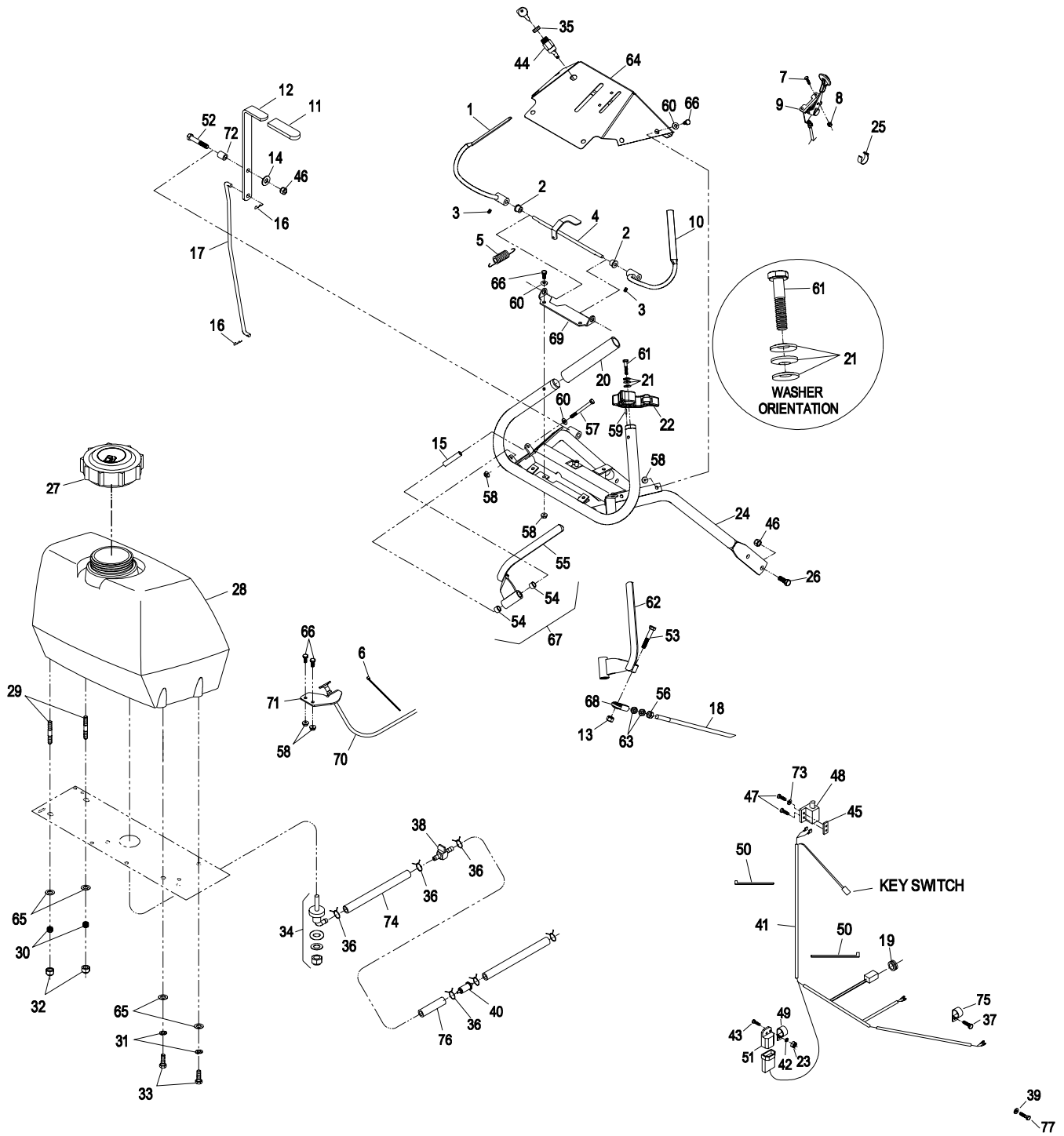

DECALS

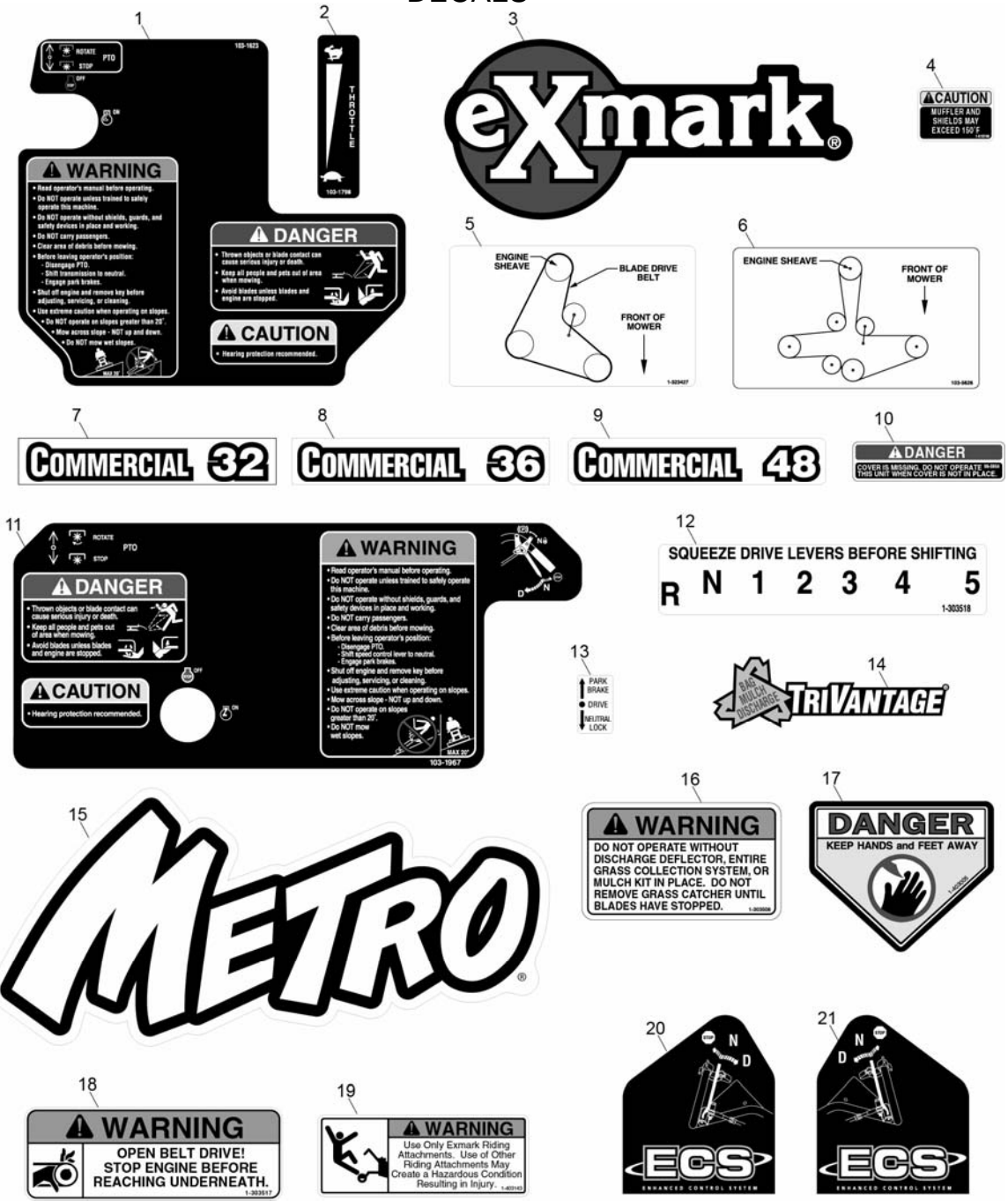

Item	Part No.	Description	Qty.
1●	103-1623	Decal, Console	1
2	103-1798	Decal, Throttle	1
3	103-2882	Decal, Exmark Logo.....	1
4	1-513746	Decal, Muffler.....	1
5	1-323427	Decal, Belt Routing (32" & 36").....	1
6	103-5626	Decal, Belt Routing (48").....	1
7	1-323410	Decal, Commercial (32").....	1
8	1-323411	Decal, Commercial (36").....	1
9	1-403131	Decal, Commercial (48").....	1
10	98-5954	Decal, Missing Cover	1
11★	103-1967	Decal, Console	1
12	1-303518	Decal, Shifter	1

Item	Part No.	Description	Qty.
13★	1-323550	Decal, Neutral/Brake.....	2
14	1-303520	Decal, TriVantage	1
15	103-2920	Decal, Metro Model.....	1
16	1-303508	Decal, Discharge Warning	1
17	1-403005	Decal, Danger (32" & 36").....	1
	1-403005	Decal, Danger (48")	2
18	1-303517	Decal, Belt Drive	1
19	1-403143	Decal, Sulky Warning.....	1
20●	103-2245	Decal, ECS Instruction (RH)	1
21●	103-2244	Decal, ECS Instruction (LH).....	1
	103-2640	Decal, Kit	1

- ★ Pistol Grip units only.
- ECS units only.

WIRING DIAGRAMS

KAWASAKI

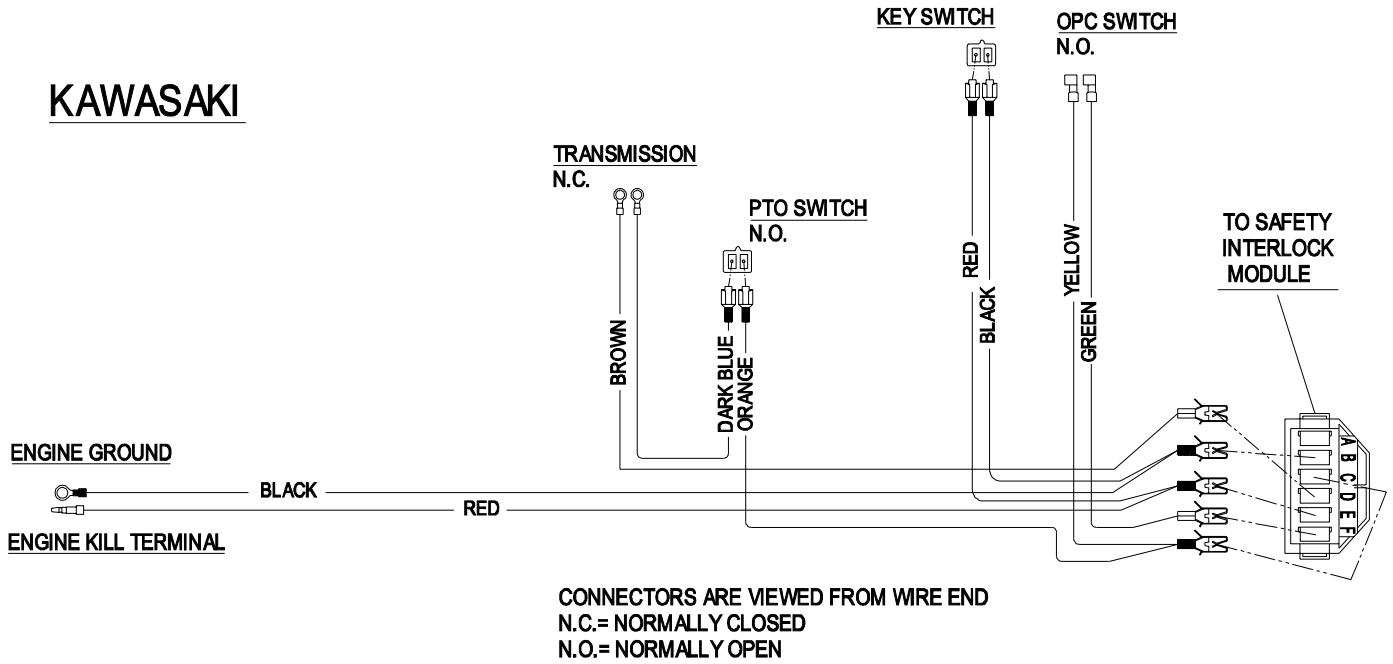

NOTES

SEE EXMARK'S COMPLETE LINE OF ACCESSORIES

RIDING ACCESSORIES

CUSTOM RIDE SEAT SUSPENSION SYSTEM
DECK LIFT ASSIST KIT
HITCH KIT
LIGHT KIT
MICRO-MULCH SYSTEM
ROLL OVER PROTECTION SYSTEM (ROPS)
SNOW BLADE
SUN SHADE
TRASH CONTAINER
TURF STRIPER
ULTRA VAC COLLECTION SYSTEM
ULTRA VAC QUICK DISPOSAL SYSTEM

WALK BEHIND ACCESSORIES

GRASS CATCHER
MICRO-MULCH SYSTEM
STEERABLE SULKY
SULKY HITCH KIT
TURF STRIPER
STANDON

Check us out on the Web:
www.exmark.com

© 1997-2006 EXMARK MFG. CO. INC.
INDUSTRIAL PARK BOX 808
BEATRICE, NE 68310

PART NO. 109-4171 Rev. A
(402) 223-6300
FAX (402) 223-5489

ALL RIGHTS RESERVED

PRINTED IN U.S.A.

