

For Serial Nos.
670,000 & Higher

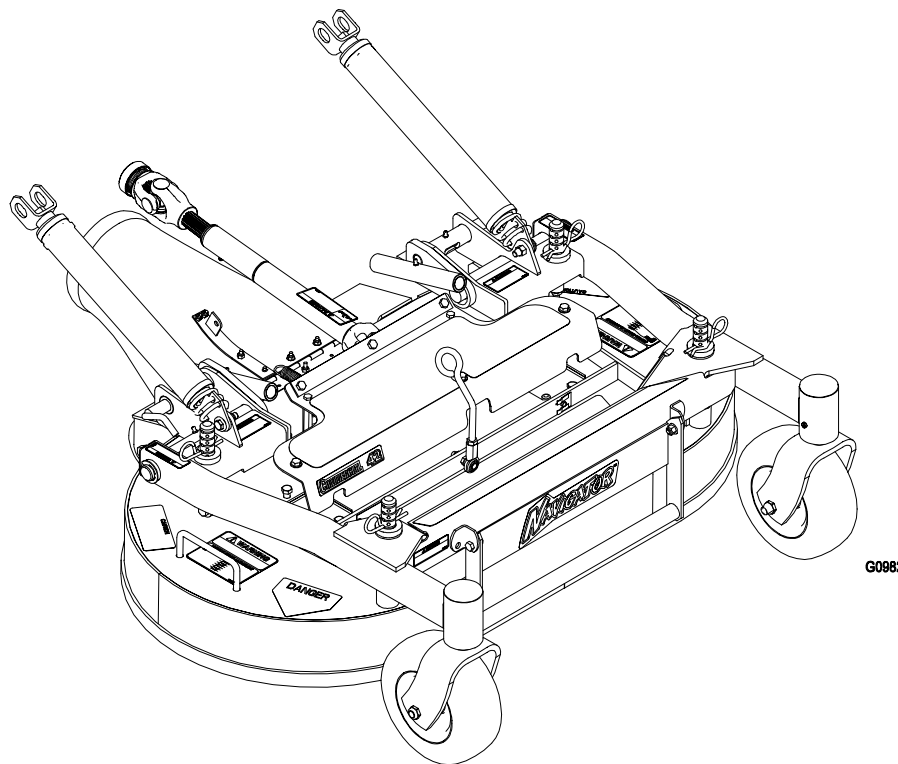

NAVIGATOR CD42CD/CD48CD

CONGRATULATIONS on the purchase of your new Exmark equipment. This product has been carefully designed and manufactured to give you a maximum amount of dependability and years of trouble-free operation. If additional information is needed, or should you require trained mechanic service, contact your authorized Exmark equipment dealer or distributor. If you need to order replacement parts from your dealer, always give the model number and serial number of your equipment as well as the part number, description and quantity of the part needed.

The Serial No. plate is located on the top of the deck in front of the right spindle. For ease of ordering and reference, we suggest that you record the information requested in the following identification table.

Place Model No. and Serial No. Label Here
(Included in Literature Pack)
or Fill in Below

Model No. _____

Serial No. _____

Date Purchased _____

OPERATOR'S & PARTS MANUAL

EXMARK PARTS PLUS® PROGRAM

EFFECTIVE DATE: September 1, 1995

Program

If your Exmark dealer does not have the Exmark part in stock, Exmark will get the parts to the dealer the next business day or the part will be FREE* Guaranteed!!

How the Program Works

1. If dealer does not have part in stock for a "down" unit at the time of request by customer, the dealer contacts his distributor by 1:00 p.m., local time, and requests Exmark Parts Plus® shipment of six (6) line items or less.
2. Distributor ships part(s) to dealer or customer, as requested by dealer, same day, overnight UPS. Distributor bills dealer for part and freight charges where applicable.
3. If distributor does not have the part(s) in stock to satisfy Exmark Parts Plus® order, he contacts Exmark by 3:00 p.m., central time, with an Exmark Parts Plus® order of six (6) line items or less.
4. If order is received by 3:00 p.m. central time, Exmark ships part(s) direct to dealer or customer, as requested by distributor, same day, overnight UPS, Exmark bills the distributor for parts and shipping charges, where applicable.
5. The customer pays for the part and freight if it is shipped under the Exmark Parts Plus® and if it arrives in accordance to the program.
6. Who pays for the part and freight if it fails to arrive overnight in accordance to the program?
 - A. Under any circumstance the customer does not pay.
 - B. If the part does not arrive overnight due to:
 1. The dealer not submitting the Exmark Parts Plus® order to his Exmark distributor by 1:00 p.m., the dealer pays for the part and freight.
 2. The Distributor being unable to ship the part the same day or not submitting the Exmark Parts Plus® order to Exmark by 3:00 p.m., central time, the Distributor pays for the part and freight.
 3. Exmark being unable to ship the part and the Exmark parts order is received by 3:00 p.m., central time, Exmark pays for the part and freight.
 4. If the part does not arrive overnight due to the shipper (UPS), the shipper pays for the freight and Exmark pays for the part.

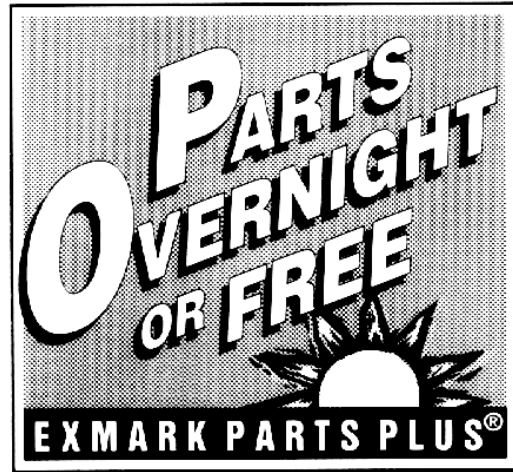

The following restrictions apply -- The Exmark Parts Plus® Program is available only through participating Exmark Dealers and applies only to orders submitted on this program Monday through Thursday. Parts Plus service is available only in the 48 contiguous United States. UPS has initiated a Saturday delivery program to many areas of the continental United States and can be requested for an overnight shipment on Friday to be delivered Saturday. The next day air charge, plus the Saturday delivery fee will be the responsibility of the purchaser. Exmark Mfg. will assume no responsibility for Saturday delivery shipments. To qualify, all Exmark Parts Plus® orders must be received by Exmark by 3:00 p.m., central time. Orders must be six (6) line items or less. Exclusions from the Exmark Parts Plus® Program are: Any wholegood or accessory in its entirety, engines and engine replacement parts, 5-speed Peerless transmissions and 5-speed transaxles, hydraulic or hydrostatic wheel motors, cutter decks and engine decks or any item exceeding United Parcel Service size and weight restrictions.

Due to UPS restrictions, aerosol spray paint is considered a hazardous material and cannot be shipped via UPS next day or Second Day Air.

Exmark Manufacturing stocks a limited supply of parts for transaxles, pumps and wheel motors. These parts can be ordered for Next Day Air shipment but will not be guaranteed per the Parts Plus Program.

 WARNING 	
POTENTIAL HAZARD	
◆ This product is a piece of power equipment.	
WHAT CAN HAPPEN	
◆ Failure to follow safe operating practices can result in serious operator injury or even death.	
HOW TO AVOID THE HAZARD	
◆ Keep all shields, guards, and safety devices (especially the grass discharge system) in place and in proper working condition.	
◆ Stop engine, wait for all moving parts to stop, and engage parking brake. Remove spark plug wire(s) or remove key before adjusting, servicing, or performing maintenance.	
◆ If mower deck becomes clogged, stop engine, wait for all moving parts to stop, and engage parking brake. Remove spark plug wire(s) or remove key before cleaning blockage.	
◆ Keep hands, feet, and clothing away from power driven parts.	
◆ Keep off mower unless seat platform is provided.	
◆ Keep others off mower.	

CONGRATULATIONS on the purchase of your Exmark Navigator Cutting Deck. This product has been carefully designed and manufactured to give you a maximum amount of dependability and years of trouble-free operation.

OPERATOR'S MANUAL

This manual contains assembly, operating, maintenance, adjustment, and safety instructions for your Navigator Cutting Deck.

BEFORE OPERATING YOUR MOWER, CAREFULLY READ THIS MANUAL IN ITS ENTIRETY.

By following the operating, maintenance, and safety instructions, you will prolong the life of your equipment, maintain its maximum efficiency, and promote safe operation.

If additional information is needed, or should you require trained mechanic service, contact your authorized Exmark equipment dealer or distributor.

All Exmark equipment dealers and distributors are kept informed of the latest methods of servicing and are equipped to provide prompt and efficient service in the field or at their service stations. They carry ample stock of service parts or can secure them promptly for you from the factory.

All Exmark parts are thoroughly tested and inspected before leaving the factory, however, attention is required on your part if you are to obtain the fullest measure of satisfaction and performance.

TABLE OF CONTENTS

	PAGE
1. SAFETY	
1.1 Safety Alert Symbol	1
1.2 Training	1
1.3 Preparation.....	1-2
1.4 Operation	2-3
1.5 Maintenance & Storage	3
1.6 Safety Signs	3
2. SPECIFICATIONS	
2.1 Model Number	4
2.2 Dimensions.....	4
2.3 Torque Requirements.....	4
3. ASSEMBLY INSTRUCTIONS	
3.1 Assemble Deck to Navigator	4-6
3.2 Deck Removal	6
4. MAINTENANCE & ADJUSTMENTS	
4.1 Deck Raising and Lowering	7-8
4.2 Adjusting the Fill Reduction System (FRS) Baffles	9-10
4.3 Maintenance.....	10-13
4.4 Adjustments	13-14
5. PARTS LIST	
5.1 Deck Group	15-16
5.2 Front Frame Group.....	17-18
5.3 Gearbox Components	19
6. WARRANTY	20

1. SAFETY

1.1 SAFETY ALERT SYMBOL

This SAFETY ALERT SYMBOL  is used both in this manual and on the unit to identify important safety messages which must be followed to avoid accidents. This symbol means:

ATTENTION! BECOME ALERT!
YOUR SAFETY IS INVOLVED!

The safety alert symbol appears above information which alerts you to unsafe actions or situations and will be followed by the word **DANGER**, **WARNING**, or **CAUTION**.

DANGER: White lettering / Red background. Indicates an imminently hazardous situation which, if not avoided, **WILL** result in death or serious injury.

WARNING: Black lettering / Orange background. Indicates a potentially hazardous situation which, if not avoided, **COULD** result in death or serious injury.



CAUTION: Black lettering / Yellow background. Indicates a potentially hazardous situation which, if not avoided, **MAY** result in minor or moderate injury.

1.2 TRAINING

- 1.2.1 Regard the Exmark mower as a piece of power equipment and teach this regard to all who operate this unit.
- 1.2.2 Before operating your mower, read the Navigator tractor and cutting deck manual instructions carefully. Familiarize yourself with the controls and the proper use of the equipment. If the operator(s) or mechanic(s) can not read English, it is the owner's responsibility to explain this material to them.
- 1.2.3 Do not allow operation of this machine by untrained personnel. Never allow children, teenagers, or people unfamiliar with these instructions to use the mower. Local regulations may restrict the age of the operator.
- 1.2.4 Avoid mowing while people, especially children, or pets, are nearby. Keep in mind that the operator or user is responsible for accidents or hazards occurring to other people or their property.

1.3 PREPARATION



- 1.3.1 Do not modify the Navigator cutting deck and only use on approved Exmark machines.
- 1.3.2 The use of personal protective equipment, such as (but not limited to) protection for the eyes, ears, feet, and head is recommended.

 CAUTION 	
POTENTIAL HAZARD	
◆ This machine produces sound levels in excess of 85 dBA at the operator's ear when in operation.	
WHAT CAN HAPPEN	
◆ Exposure to sound levels of 85 dBA or above for extended periods of time can cause hearing loss.	
HOW TO AVOID THE HAZARD	
◆ Wear hearing protection when operating this machine.	

- 1.3.3 While mowing, always wear substantial footwear and long trousers. Do not operate equipment when barefoot or when wearing open sandals.
- 1.3.4 Thoroughly inspect the area where the equipment is to be used and remove all stones, sticks, wires, bones, and other foreign objects which may damage the equipment or cause personal injury to the operator or bystanders.

1.4 OPERATION

Although hazard control and accident prevention are partially dependent upon the design and configuration of the equipment, these factors are also dependent upon the awareness, concern, prudence, and proper training of the personnel involved in the operation, transport, maintenance, and storage of the equipment. It is essential that all Operator Safety Mechanisms be connected and in operating condition prior to use for mowing.

 WARNING 	
POTENTIAL HAZARD	
◆ Hands, feet, hair, clothing, or accessories can become entangled in rotating parts.	
WHAT CAN HAPPEN	
◆ Contact with rotating parts can cause traumatic amputation or severe lacerations.	
HOW TO AVOID THE HAZARD	
◆ DO NOT operate the machine without guards, shields, and safety devices in place and working properly.	
◆ Keep hands, feet, hair, jewelry, or clothing away from rotating parts.	

- 1.4.1 Give complete, undivided attention to the job at hand.
- 1.4.2 Mow only in daylight or good artificial light, keeping away from holes and hidden hazards. **NEVER** carry passengers.
- 1.4.3 Use **EXTREME** caution when backing up. **LOOK BEHIND YOU!**
- 1.4.4 Stop the blades when crossing surfaces other than grass and when transporting the mower to and from the area to be mowed.

- 1.4.5 Never operate the mower with damaged guards, shields, or covers. Always have safety shields, guards, switches, and other devices in place and in proper working condition.

1.5 MAINTENANCE AND STORAGE

- 1.5.1 Check all bolts frequently to maintain proper tightness.
- 1.5.2 Keep all guards, shields, and all safety devices in place and in safe working condition.
- 1.5.3 Frequently check for worn or deteriorating components that could create a hazard.
- 1.5.4 All replacement parts must be the same as or equivalent to the parts supplied as original equipment.

1.6 SAFETY SIGNS

- 1.6.1 Keep all safety signs legible. Remove all grease, dirt and debris from safety signs and instructional labels.
- 1.6.2 Safety signs must be replaced if they are missing or illegible.
- 1.6.3 When new components are installed, be sure that current safety signs are affixed to the replaced components.
- 1.6.4 New safety signs may be obtained from Exmark Mfg. Co. Inc.
- 1.6.5 Safety signs may be affixed by peeling off the backing to expose the adhesive surface. Apply only to a clean, dry surface. Smooth to remove any air bubbles.
- 1.6.6 Familiarize yourself with the following safety signs and instruction labels. They are critical to the safe operation of your Exmark commercial mower.



PART NO. 103-8797
LOCATION: On Top RH and LH Sides of Front Frame



PART NO. 68-8340
LOCATION: On Top of Deck LH & RH Sides



PART NO. 1-403005
LOCATION: On Top of Mower Deck LH & RH Sides



PART NO. 98-5954
LOCATION: - On Top of Deck, Under Gear Box Cover
- On LH Frame, Under PTO Shield
- On RH Lower Frame, behind fuel tank



PART NO. 103-8798
LOCATION: Front RH Surface of Front Frame



PART NO. 103-8799
LOCATION: On Top of Front Frame, Near Deck Springs

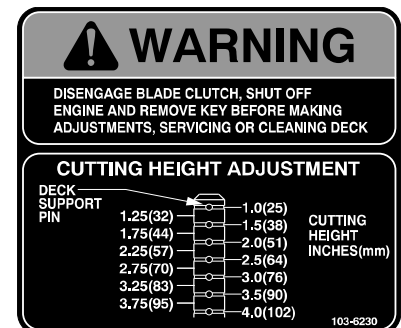

PART NO. 103-6230
LOCATION: On Top of Deck, Centered on Each Side



PART NO. 103-8425
LOCATION: On Driveshaft

2. SPECIFICATIONS

2.1 **MODEL NUMBER:** CD42CD; CD48CD

2.2 DIMENSIONS

	42" Deck	48" Deck
Overall Width	43.2" (109.7 cm)	49.2" (125.0 cm)
Overall Height	13.1" (33.3 cm)	13.1" (33.3 cm)
Overall Length	37.2" (94.4 cm)	39.9" (101.3 cm)
Weight	295 lbs. (134 kg)	325 lbs. (147 kg)

2.3 TORQUE REQUIREMENTS

<u>Bolt Location</u>	<u>Torque</u>
Blade Mounting Bolt.....	85-110 ft-lbs. (115-149 N-m)
Gearbox Mounting Bolts	30-35 ft-lbs. (41-47 N-m)
Gearbox Assembly Bolts.....	50-55 ft-lbs. (68-75 N-m)
Blade Shear Bolts.....	80-100 in-lbs. (922-1130 N-cm)

3. ASSEMBLY INSTRUCTIONS

WARNING

POTENTIAL HAZARD

- ◆ Operating a Navigator tractor without an approved Exmark front mount attachment increases the possibility of operator entanglement in drive wheels or forward tip over.

WHAT CAN HAPPEN

- ◆ Entanglement or tip-over could cause serious injury or death.

HOW TO AVOID THE HAZARD

- ◆ When operating a Navigator tractor without an approved Exmark front mount attachment, observe the following:
 - * DO NOT transport without a front mount attachment properly installed.
 - * Operation should be limited to only moving unit to install a different front mount attachment.
 - * Only operate on a flat level surface.
 - * Avoid sudden acceleration or deceleration.
 - * Reduce speed and use extreme caution.

3.1 ASSEMBLE DECK TO NAVIGATOR

IMPORTANT: Do not transport Navigator tractor without an approved Exmark front mount attachment.

- a) Stop engine, wait for all moving parts to stop and remove key. Engage parking brake.
- b) Roll the mower deck up to the Navigator tractor with the discharge tube down, making sure the deck springs are located above the drive wheel and below the console on each side.

- c) Raise seat and install drive shaft onto jackshaft (See Figure 1).

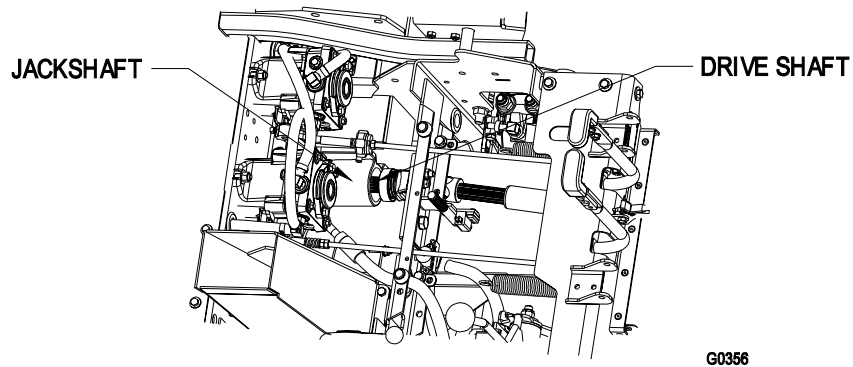

FIGURE 1

- d) Align deck push arm tubes to tractor push arms and push deck rearward. Secure push arms with lynch pins on left and right sides of the unit. See Figure 2.

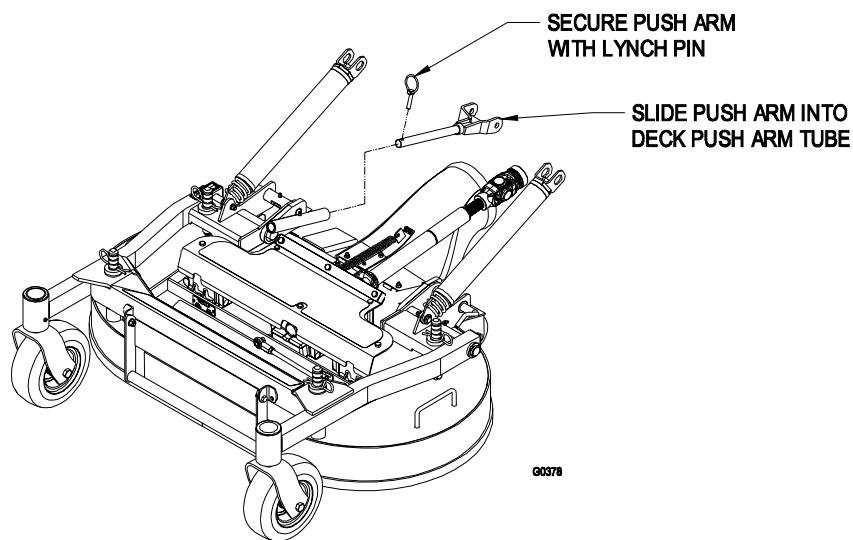

FIGURE 2

- e) Align upper portion of the PTO rubber guard to the tabs on the front of the console and secure with a clevis pin and hairpin on each side. See Figure 3.

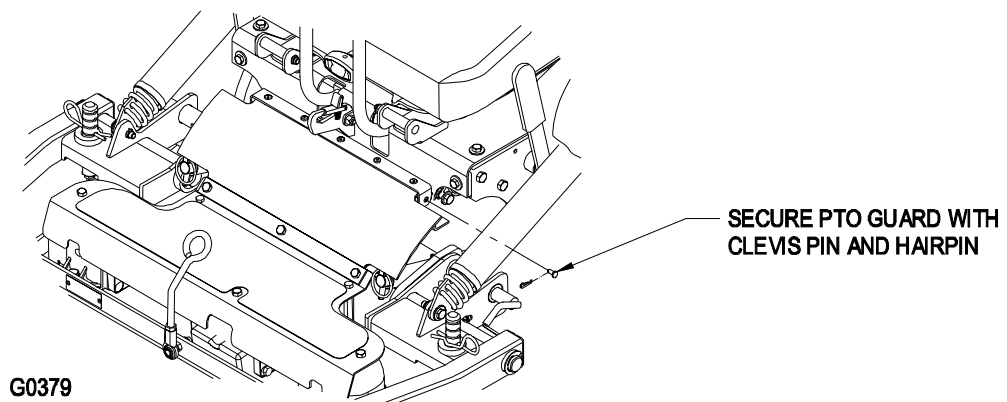

FIGURE 3

- f) Release the deck locking pins on each side, raise mower deck to the service position and secure deck latch onto hook. See section 4.1.1, Raising the Deck to the Service Position.

- g) Install springs onto the spring anchor pins under the left and right consoles and secure with a washer and hairpin. See Figure 4.

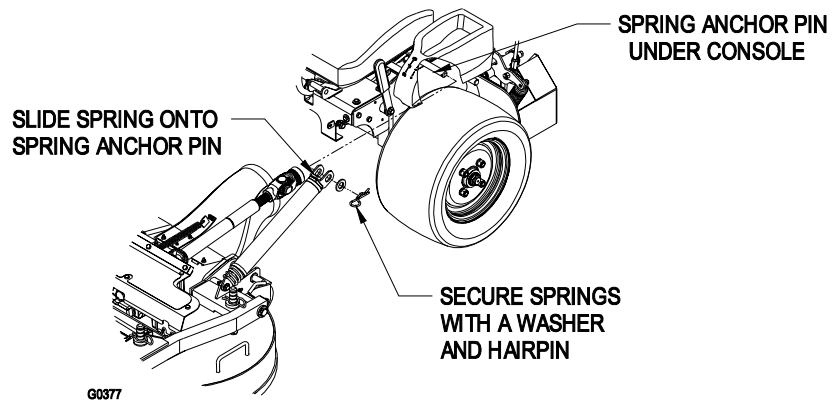

FIGURE 4



- h) Un-latch deck from raised position, slowly lower deck to ground and lock deck locking pins on each side per section 4.1.2, Lowering the Deck to the Operation Position.

3.2 DECK REMOVAL

- a) Stop engine, wait for all moving parts to stop, and remove key. Engage parking brake.
- b) Raise mower deck up and latch with deck locking pins per section 4.1.1, Raising the Mower Deck to the Service Position.
- c) Remove hairpins and washers at the top of the deck lift assist spring on each side of the unit. See Figure 4.
- d) Remove the spring from the spring anchor. Repeat for other side of unit.
- e) Un-latch deck from raised position and slowly lower deck to ground per section 4.1.2, Lowering the Mower Deck to the Operation Position.
NOTE: Deck will become heavier once springs are removed from the anchors. Lower deck carefully.
- f) Remove lynch pins at front of push arms on both sides of the unit. See Figure 2.
- g) Remove hairpin and clevis from both sides of the PTO guard. See Figure 3.
- h) Raise seat and disconnect drive shaft using quick coupler at jackshaft. See Figure 1.
- i) Pull mower deck forward to remove from unit.

IMPORTANT: Do not transport Navigator tractor without an approved Exmark front mount attachment.



4. MAINTENANCE & ADJUSTMENTS

 WARNING 	
POTENTIAL HAZARD <ul style="list-style-type: none">◆ While maintenance or adjustments are being made, someone could start the engine.	
WHAT CAN HAPPEN <ul style="list-style-type: none">◆ Accidental starting of the engine could seriously injure you or other bystanders.	
HOW TO AVOID THE HAZARD <ul style="list-style-type: none">◆ Remove the key from the ignition switch and engage parking brake. Pull the wire(s) off the spark plug(s) before you do any maintenance. Also push the wire(s) aside so it does not accidentally contact the spark plug(s).	

4.1 DECK RAISING AND LOWERING

4.1.1 Raising the Mower Deck into Service Position:

- a) Stop engine, wait for all moving parts to stop and remove key. Engage parking brake.

 WARNING 	
POTENTIAL HAZARD <ul style="list-style-type: none">◆ Incorrectly raising or lowering a mower deck can be dangerous.	
WHAT CAN HAPPEN <ul style="list-style-type: none">◆ A dropped mower deck can result in a serious injury or property damage.	
HOW TO AVOID THE HAZARD <ul style="list-style-type: none">◆ Always raise and lower deck on flat, dry ground, free of any obstructions.◆ Firmly grasp the deck lift handle and lower in a slow controlled manner.◆ Always make sure the deck is securely latched in the “up” or “down” position.	

- b) Release the deck locking pins on each side. See Figure 5.

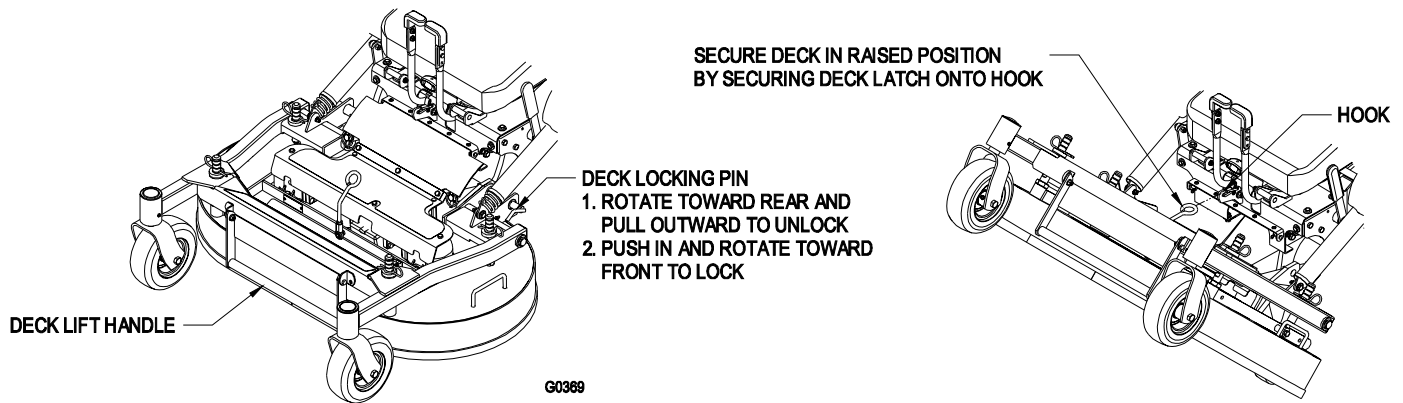

FIGURE 5

- c) Using deck lift handle, lift deck up and latch in “up” position (latch is located at front center of seat). See Figure 5.

WARNING	
POTENTIAL HAZARD	
<ul style="list-style-type: none"> ◆ Operating the mower deck in the raised service position can be dangerous. 	
WHAT CAN HAPPEN	
<ul style="list-style-type: none"> ◆ Engaging the PTO with a deck in the raised position can result in a serious injury or property damage. 	
HOW TO AVOID THE HAZARD	
<ul style="list-style-type: none"> ◆ Always lower and lock mower deck in the operation position before engaging the PTO. 	

4.1.2 Lowering the Mower Deck to the Operation Position:

- a) While firmly holding onto deck lift handle, unhook deck latch from tractor section and slowly lower deck to ground.
- b) Push deck locking pins inward and rotate forward to securely lock deck in lowered position. See Figure 5.

WARNING	
POTENTIAL HAZARD	
<ul style="list-style-type: none"> ◆ Operating mower without locking pins securely latched can result in the mower deck folding up unexpectedly. 	
WHAT CAN HAPPEN	
<ul style="list-style-type: none"> ◆ The mower deck folding up unexpectedly can cause serious injury. 	
HOW TO AVOID THE HAZARD	
<ul style="list-style-type: none"> ◆ Always operate mower with locking pins securely latched. 	

4.2 ADJUSTING FILL REDUCTION SYSTEM (FRS) BAFFLES

4.2.1 The Navigator's exclusive Fill Reduction System has been designed to allow you to reduce the amount of clippings collected by varying degrees. Advantages include less frequent emptying of the hopper and return of nutrients to the soil.

Possible Configurations:

1. Baffles open, standard blades – Maximum collection
2. Baffles closed, standard blades – Partial mulching
3. Baffles closed, mulch blades – Intermediate mulching
4. Mulch plug installed, mulch blades – Complete mulching (requires mulch kit)

4.2.2 To adjust the FRS baffles:

- a) Stop engine, wait for all moving parts to stop and remove key. Engage parking brake.
- b) Remove hair pins and clevis pins from both sides of the PTO guard. See figure 3. Fold guard forward.
- c) Loosen nyloc nuts on the rear studs of the FRS baffles.

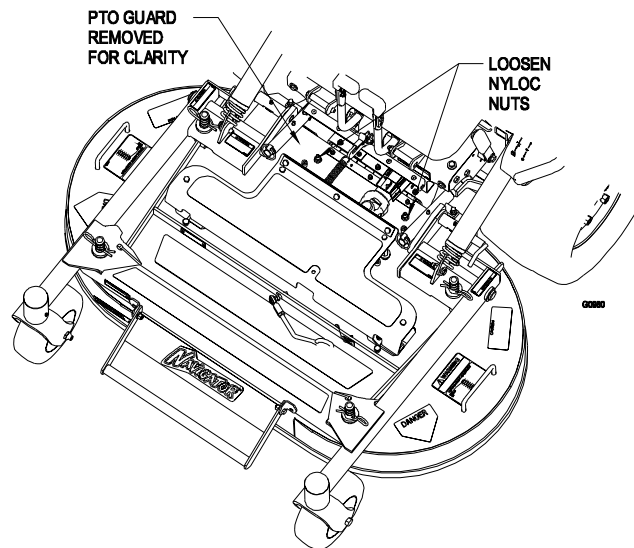

FIGURE 6

- d) Raise deck per section 4.1.1
- e) Remove bolt and washer at the front of each of the FRS baffles. Rotate baffles into desired position and reinstall bolt and washer.

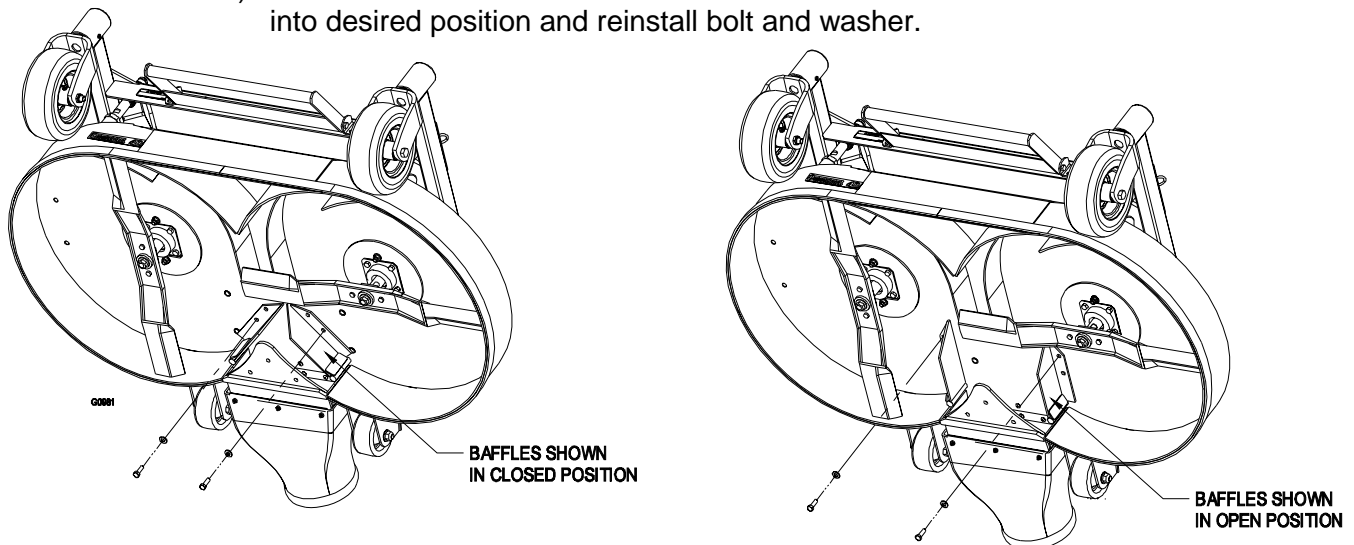

FIGURE 7

- f) Lower deck per section 4.1.2
- g) Snug nyloc nuts on the rear studs of the FRS baffles. These nuts may be left slightly loose if frequent baffle adjustment is anticipated.
- h) Reinstall PTO guard using clevis pins and hair pins removed in step b.

4.3 PERIODIC MAINTENANCE

4.3.1 Clean grass build-up under deck.

Service Interval: Daily

- a) Stop engine, wait for all moving parts to stop, and remove key. Engage parking brake.
- b) Raise mower deck and secure in latched position. See section 4.1.1, Raising the Mower Deck to the Service Position.
- c) Clean out any grass build-up from underside of deck and in discharge chute.
- d) Lower deck to cutting position and lock deck locking pins. See section 4.1.2, Lowering the Mower Deck to the Operation Position.



4.3.2 Check mower blades.

Service Interval: Daily

- a) Stop engine, wait for all moving parts to stop, and remove key. Engage parking brake.
- b) Lift deck and secure in raised position as stated in Section 4.1.1, Raising the Mower Deck to the Service Position.
- c) Inspect blades and sharpen or replace as required.
- d) To remove blade, use a block of wood or locking pliers to hold blade in place and remove the 1/2-20 x 2 1/4 blade bolt that secures the blade and blade driver.
- e) If blade is worn or damaged, remove the shear bolts that secure the blade driver to the blade. Re-install a new blade to the blade driver and secure with the shear bolts. Torque shear bolts to 80-100 in-lbs. (922-1130 N-cm).
- f) Re-install the blade driver (with new blades) by using a block of wood or locking pliers to hold the blade in place and torque the blade bolts to 85-110 ft-lbs. (115-149 N-m).

NOTE: Blade driver flats must be aligned with the flats on the shaft when installing blade on the mower deck.

- g) Lower the mower deck to the operation position. See section 4.1.2, Lowering the Mower Deck to the Operation Position.

 CAUTION 
POTENTIAL HAZARD <ul style="list-style-type: none">◆ Operating a mower deck with loose or weakened blade bolts can be dangerous.
WHAT CAN HAPPEN <ul style="list-style-type: none">◆ A loose or weakened blade bolt could allow a blade rotating at a high speed to come out from under the deck, causing serious injury or property damage.
HOW TO AVOID THE HAZARD <ul style="list-style-type: none">◆ Replace the blade bolt after striking a foreign object.◆ Use only genuine Exmark replacement parts.◆ DO NOT lubricate the threads of the bolt or spindle before assembly.◆ Torque the blade bolt to 85-110 ft. lbs. (115-149 N-m)◆ Torque the shear bolts to 80-100 in-lbs (922-1130 N-cm)

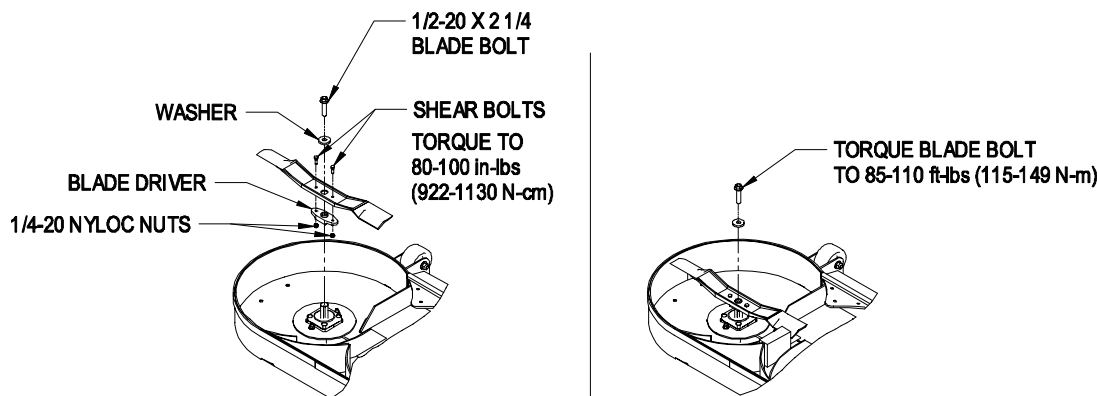

FIGURE 8

4.3.3 Check for loose hardware:

Service Interval: Daily

- a) Stop engine, wait for all moving parts to stop, and remove key. Engage parking brake.
- b) Visually inspect machine for any loose hardware or any other possible problem. Tighten hardware or correct the problem before operating the unit.

4.3.4 Check tire pressures:

The front caster tires are semi-pneumatic and do not need to be inflated.

NOTE: Do not add any type of tire liner or foam fill material to the tires.

Excessive loads created by foam filled tires may cause failures to the hydro drive system, frame, and other components. Foam filling tires will void the warranty.

4.3.5 Lubricate grease fittings:

Service Interval: Refer to chart.

- a) Stop engine, wait for all moving parts to stop, and remove key. Engage parking brake.
- b) Lubricate fittings with one to two pumps of NGLI grade #2 multi-purpose gun grease.

Refer to the following chart for fitting locations and lubrication schedule.

GREASE FITTING LUBRICATION CHART

FITTING LOCATIONS	INITIAL PUMPS	NO. of PLACES	SERVICE INTERVAL
1. Drive Shaft	1	3	40 hours
2. Front Caster Wheel Hub	1	2	8 hours
3. Deck Flip-Up	1	4	100 hours
4. Push Arm Tubes	1	2	100 hours
5. Caster Pivots	*0	2	*yearly

* See Section 4.2.5 c) for special lubrication instructions on the front caster pivots.

- c) Lubricate caster pivots once a year. Remove hex plug and cap. Thread grease zerk in hole and pump with grease until it oozes out around top bearing. Remove grease zerk and thread plug back in. Place cap back on.

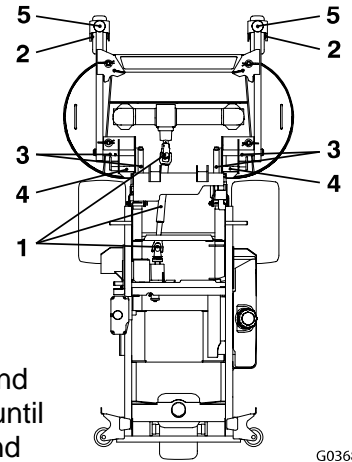

G0368

4.3.6 Change gearbox oil:

Change oil in all 3 gearbox housings after first 50 hrs of operation. Check every 100 hours thereafter. Add oil as needed until level with oil drain plug.

- a) Stop engine, wait for all moving parts to stop, and remove key. Engage parking brake.
- b) Place unit on a level surface.
- c) Remove the gearbox and drive shaft assembly from the mower deck. Retain hardware for re-use.
- d) Remove the large oil drain plug on the front of each of the 3 gearbox sections and drain oil. See Figure 9.
- e) Remove small magnetic plugs and wipe away any material accumulated on the plugs. See Figure 9.

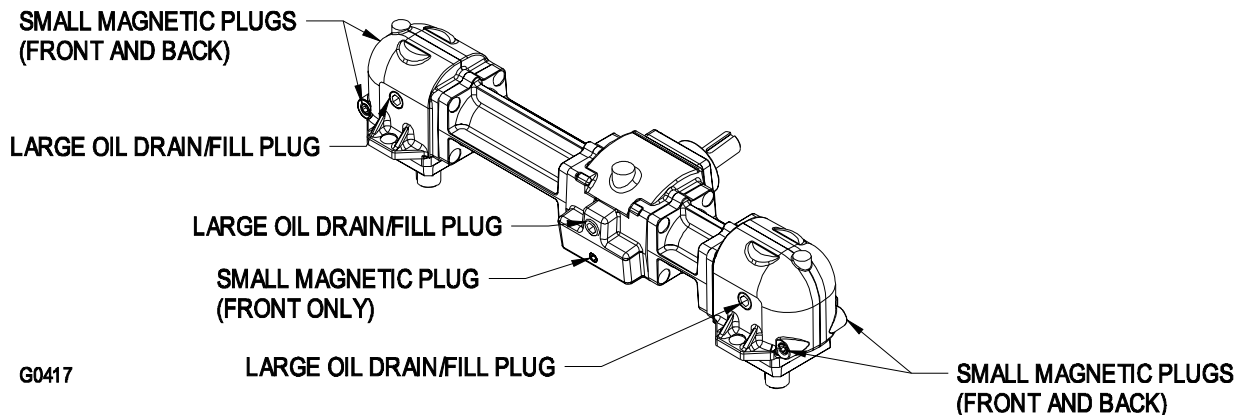

G0417

FIGURE 9

- f) Apply a Teflon pipe sealant to all small magnetic plugs and re-install into the gearbox.
- g) Re-install the gearbox and drive shaft assembly to the mower deck.
- h) Fill gearbox with Mobil SHC (synthetic) 75W-90 gear lube oil until level with oil drain/fill plug. Each of the gearbox sections must be filled separately.

NOTE: Mower deck should remain level to the ground when filling gearbox with oil. Do not fill gearbox with deck raised in the service position.

- i) Apply a Teflon pipe sealant to the 3 large oil plugs and re-install into the gearbox.

4.3.7 Thread locking adhesives such as “Loctite 242” or “Fel-Pro, Pro-Lock Nut Type” are used on the following fasteners:

- a) Caster wheel spacer nuts.

4.4 ADJUSTMENTS

IMPORTANT: Disengage PTO, shut off engine, wait for all moving parts to stop, remove key and engage parking brake before servicing, cleaning, or making any adjustments to the unit.

4.4.1 Cutting Height Adjustment:

- a) Stop engine, wait for all moving parts to stop, and remove key. Engage parking brake.
- b) Move cotter pins on four deck support pins to proper hole for height of cut desired.

4.4.2 Deck Leveling:

- a) Position mower on a flat surface.
- b) Stop engine, wait for all moving parts to stop, and remove key. Engage parking brake.
- c) Inflate drive tires to 15 psi (103 kPa).
- d) Verify all hairpins are in the 3” deck height holes with the spacers under the hair pins. See Figure 10.
- e) Shorten/lengthen each deck support pin to obtain blade tip height of 3.0” at the front of the deck and 3.25” at the rear of the deck.

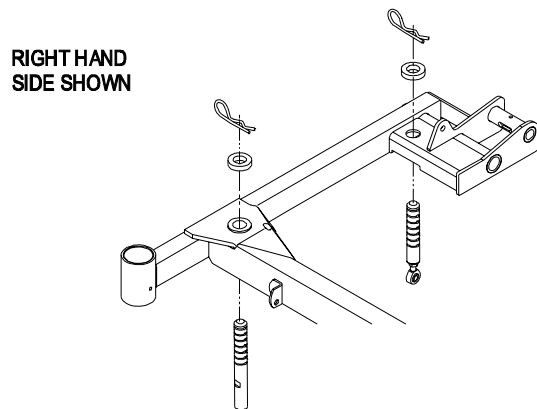

G0342

FIGURE 10

4.4.3 Caster pivot bearings pre-load adjustment:

- a) Remove dust cap from caster and tighten nyloc nut until washers are flat. Back the nyloc off 1/4 of a turn to properly set the pre-load on the bearings.

Note: If disassembled, make sure the spring washers are reinstalled as shown in Figure 11.

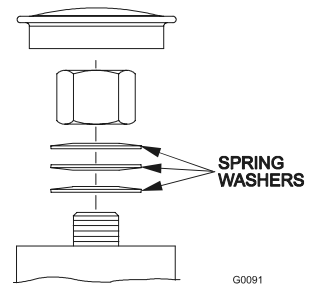

FIGURE 11

4.4.4 Deck locking pin stop adjustment:

- a) Slide deck locking pins in on both sides and rotate to lock the deck in the “operation” position.
- b) Loosen the jam nut and turn the stop screw clockwise until the locking pins is tight and cannot be rotated by hand. See Figure 12.
- c) Loosen the stop screw counter clockwise 1/2 turn and tighten the jam nut.
- d) Test the locking pin to make sure it slides freely. Readjust if necessary.

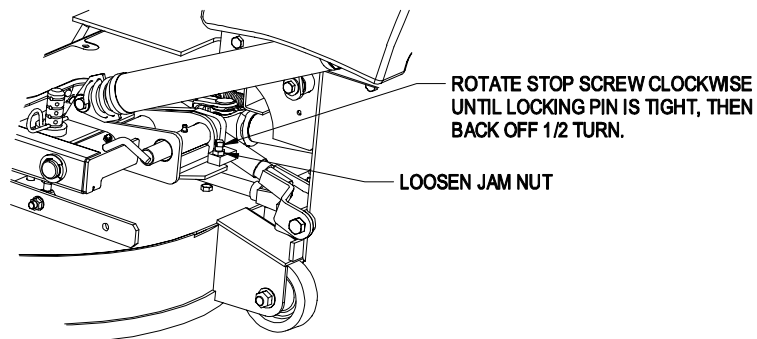

FIGURE 12

5. PARTS LIST

5.1 DECK GROUP

Item	Part No.	Description	Qty.
1★	1-403005	Danger, Decal.....	2
2	1-413425	Spacer, Deck Support.....	4
3	1-513690	Clip, Deck Holdup Rod.....	1
4	109-2365	Bumper.....	2
5	1-613204	Balljoint.....	2
6	1-803075	Screw, Truss Head #10-24 x 3/4.....	11
7	1-806003	Hairpin, Cotter.....	2
8	30-8770	Washer.....	2
9	67-7490	Key, Machine 1/4 x 1/4 x 1 1/2.....	1
10★	68-8340	Decal, Blade Bolt Torque.....	2
11	92-5816	Bolt, Blade 1/2-20 x 2 1/4.....	2
12★	98-5954	Decal, Danger.....	2
13	99-0283	Bolt, Shear 1/4-20 x 7/8.....	4
14	1-808280	Pin, Clevis 5/16 x 1.....	2
15	103-9487	Asm, Discharge Tube.....	1
16	109-0321	Asm, Front Deck Height Adj.....	2
17	109-2228-03	Guard, Plenum.....	1
18	103-3700	Roller, Deck.....	2
19✚	109-0322	Asm, Rear Deck Height Adj. (42").....	2
	109-0323	Asm, Rear Deck Height Adj. (48").....	2
20	103-9485	Asm, Drive Shaft W/Decal.....	1
	103-9327	Asm, Cross "U" Joint.....	2
	103-9328	Yoke, Keyed.....	1
	103-9329	Yoke, Quick Disconnect.....	1
21	103-4230	Spacer, Roller.....	2
22	103-4974	Hinge.....	1
23	103-5868-01	Wld, Spring Mount.....	1
24	103-5979	Guard, PTO.....	1
25	103-6183-03	Bracket, PTO Guard.....	1
26★	103-6230	Decal, Cutting Height Adjustment.....	2
27	103-6290-03	Plate, Drive Line Cover.....	1
28	103-7353	Hairpin, Cut Height.....	4
29	103-7705	Driver, Blade.....	2
30	103-7994	Balljoint.....	1
31	103-8307	Latch, Deck.....	1
32■	103-8363	Asm, Deck Latch.....	1
33★	103-8425	Decal, Driveline.....	1
34	103-8496	Nut, Jam 7/8-9.....	2
35	103-8610	Stand-Off, 1/2 Hex.....	2
36	103-8841	Spring.....	1
37	321-2	Screw, HH 1/4-20 x 1/2.....	2
38	322-3	Screw, HH 5/16-18 x 3/4.....	3
39	322-5	Screw, HH 5/16-18 x 1.....	5

Item	Part No.	Description	Qty.
40	323-11	Screw, HH 3/8-16 x 2 1/4 (42").....	2
	323-8	Screw, HH 3/8-16 x 1 1/2 (48").....	2
41	323-7	Screw, HH 3/8-16 x 1 1/4.....	4
42	323-9	Screw, HH 3/8-16 x 1 3/4.....	1
43	325-14	Screw, HH 1/2-13 x 3 1/2.....	2
44	3219-3	Nut, Hex 3/8-24.....	3
45▲	3247-2	Setscrew, 3/8-16 x 3/8.....	1
46	3256-14	Washer, #10 Std.....	9
47	3290-134	Screw, HH Machine 10-24 x 5/8.....	1
48	3290-357	Nut, Whizlock 3/8-16.....	6
49	3296-2	Nut, Nyloc #10-24.....	12
50	3296-29	Nut, Nyloc 5/16-18.....	5
51	3296-39	Nut, Nyloc 3/8-16.....	1
52	3296-6	Nut, Nyloc 3/8-24.....	1
53	1-303334	Washer, Spring Disk 5/16.....	4
54	32128-49	Nut, Whizlock 1/2-13.....	2
55	114439	Rivet.....	5
56★	103-9024	Decal, Commercial (42").....	1
	★ 1-403131	Decal, Commercial (48").....	1
57	106-5620	Spacer (42").....	2
	106-5597	Spacer (48").....	2
58◇	103-3460	Gearbox,(42") Std.....	1
	◇ 103-3387	Gearbox,48 Std.....	1
59●	109-4373	Asm, Deck W/Decals (42").....	1
	● 109-4372	Asm, Deck W/Decals (48").....	1
60	103-4209	Blade, LH (42") Black.....	1
	103-4207	Blade, LH (48") Black.....	1
61	103-4210	Blade, RH (42") Red.....	1
	103-4208	Blade, RH (48") Red.....	1
62○	103-9497	Asm, Gearbox Cover W/Decal (42").....	1
	○ 103-9496	Asm, Gearbox Cover W/Decal (48").....	1
63	109-4053-01	Wld, Baffle Discharge LH.....	1
64	109-4054-01	Wld, Baffle Discharge RH.....	1
65	103-8626	Pad, Anti Skid (42").....	1
	103-8629	Pad, Anti Skid (48").....	1
66	103-8667	Pad, Anti Skid (42").....	1
	103-8630	Pad, Anti Skid (48").....	1
67	3296-42	Nut, Nyloc 1/4-20.....	4
68	3256-23	Washer, 5/16 SAE.....	3
69	1-807533	Bolt, Carriage #10-24 x 5/8.....	3
70	3296-12	Nut, Nyloc #10-24 Thin.....	3
71	32148-7	Insert, Threaded 5/16-18.....	6

Exmark red touch up paint (spray paint - P/N 1-850337 - .6 oz liquid bottle - P/N 103-9140).

- ▲ Use Pro-Lock, Nut Type (P/N 1-840022, .5ml tube) on setscrew, item #45.
- Deck assembly includes anti skid pad, item #66.
- Gearbox cover assembly includes anti skid pad, item #62.
- Deck latch assembly includes nyloc nut, item #52.
- ✚ Rear deck height adj. assembly includes (1) whizlock nut. Item #48.
- ◇ Fill gearbox sections to drain/fill plug with Mobil SHC (synthetic) 75w-90 gear lube oil.
- ★ Decal kit P/N 103-9467 contains all decals for CD42CD and CD48CD.

5.1 DECK GROUP

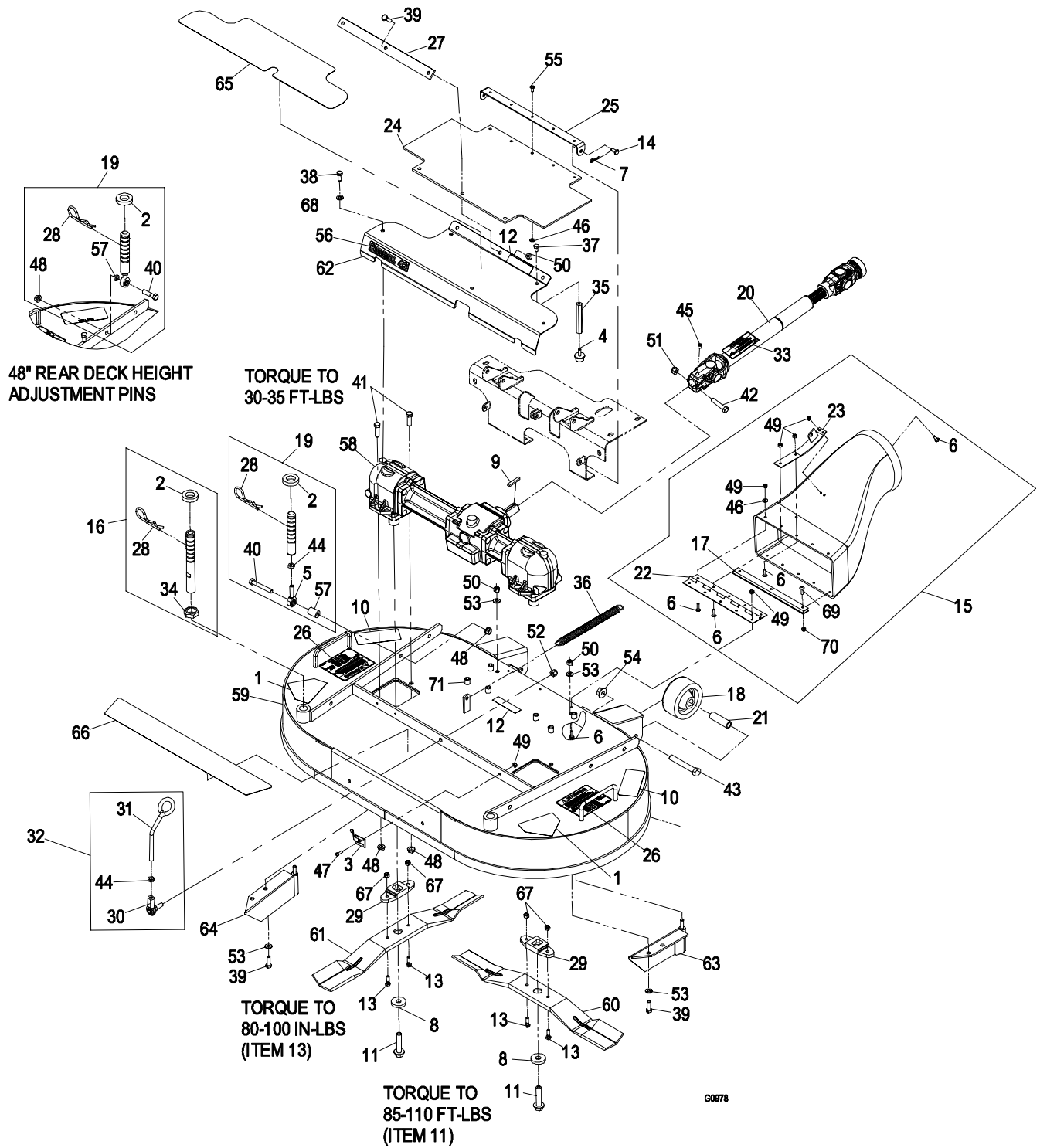

5.2 FRONT FRAME GROUP

Item	Part No.	Description	Qty.
1	1-303334	Washer, Spring Disk 5/16	2
2	1-513810	Bushing, Flanged.....	4
3	1-543508	Cup, Bearing Tapered Roller	4
4	1-543509	Cone, Bearing Tapered Roller.....	4
5	1-543511	Seal, Grease.....	2
6	1-633508	Washer, Spring Disk.....	6
7	1-811010	Plug	2
8■	103-3729-01	Wld, Deck Pivot (RH).....	1
9■	103-3732-01	Wld, Deck Pivot (LH)	1
10	103-3772	Plug, Spring Adjuster	2
11	103-3773	Shaft, Spring Adjustment	2
12	109-2094	Spacer, Front Caster.....	2
13	103-4118	Wld, Deck Lock (LH).....	1
14	103-4119	Wld, Deck Lock (RH)	1
15	103-9482	Asm, Deck Lift Handle W/Decal.....	1
16	103-4284	Wld, Spring Tensioner	2
17	103-4285	Mount, Deck Lift Spring.....	2
18	103-4588	Bearing, Roller Straight.....	2
19	103-4882	Cap, Grease	2
20	103-7353	Pin, Cut Height.....	2
21	103-7436	Bushing, Deck Support	2
22	103-7448	E-Ring.....	2
23	103-7865	Wld, Spring Tube.....	2
24	103-7971	Cover, Deck Spring.....	2
25★	103-8504	Decal, Navigator Model.....	1
26	103-8667	Pad, Anti Skid (42").....	1
	103-8630	Pad, Anti Skid (48").....	1

Item	Part No.	Description	Qty.
27★	103-8797	Decal, Folding Deck.....	2
28★	103-8798	Decal, Danger.....	1
29★	103-8799	Decal, Spring.....	2
30	302-19	Zerk, 1/4-28 Str.....	4
31	302-61	Zerk, 45° 1/4-28.....	4
32	322-4	Screw, HH 5/16-18 x 7/8.....	2
33	325-19	Screw, HH 1/2-13 x 5.....	2
34	3218-3	Nut, Jam 3/8-16.....	2
35	3243-5	Setscrew, SQH 3/8-16 x 1	2
36	3256-28	Washer, 3/4 SAE.....	2
37	3296-29	Nut, Nyloc 5/16-18.....	2
38	3296-39	Nut, Nyloc 3/8-16.....	4
39	3296-45	Nut, Nyloc 1/2-13.....	2
40	3296-51	Nut, Nyloc 3/4-10.....	2
41	32120-33	Ring, Retaining	2
42	32121-3	Rollpin 3/16 x 3/4.....	2
43	614672	Screw, Shoulder 3/8-16 x 1.295.....	2
44	109-1933-01	Wld, Fork & Spindle.....	2
45	103-4324	Asm, Wheel & Tire 8x3.00-4 Sp.....	2
46▲	103-9481	Asm, Front Frame W/Decals (42").....	1
▲	103-9480	Asm, Front Frame W/Decals (48").....	1
47	103-4281	Spring, Extension.....	2
48	103-9495	Asm, Caster Wheel W/Axle	2
49●	103-4280	Asm, Spring Lift Assist (48")	2
	109-1979	Asm, Spring Lift Assist (42")	2
50	109-1978	Spacer (42" Only)	2

Exmark red touch up paint (spray paint - P/N 1-850337 - .6 oz liquid bottle - P/N 103-9140).

- ▲ Includes frame weldment plus items #7, #13, #14, #19, #21, #25, #37, #38, and Decals.
- Include zerk, item #30.
- Includes (2) nyloc nuts, item #38.
- ★ Decal kit P/N 103-9467 contains all decals for CD42CD and CD48CD.

5.2 FRONT FRAME GROUP

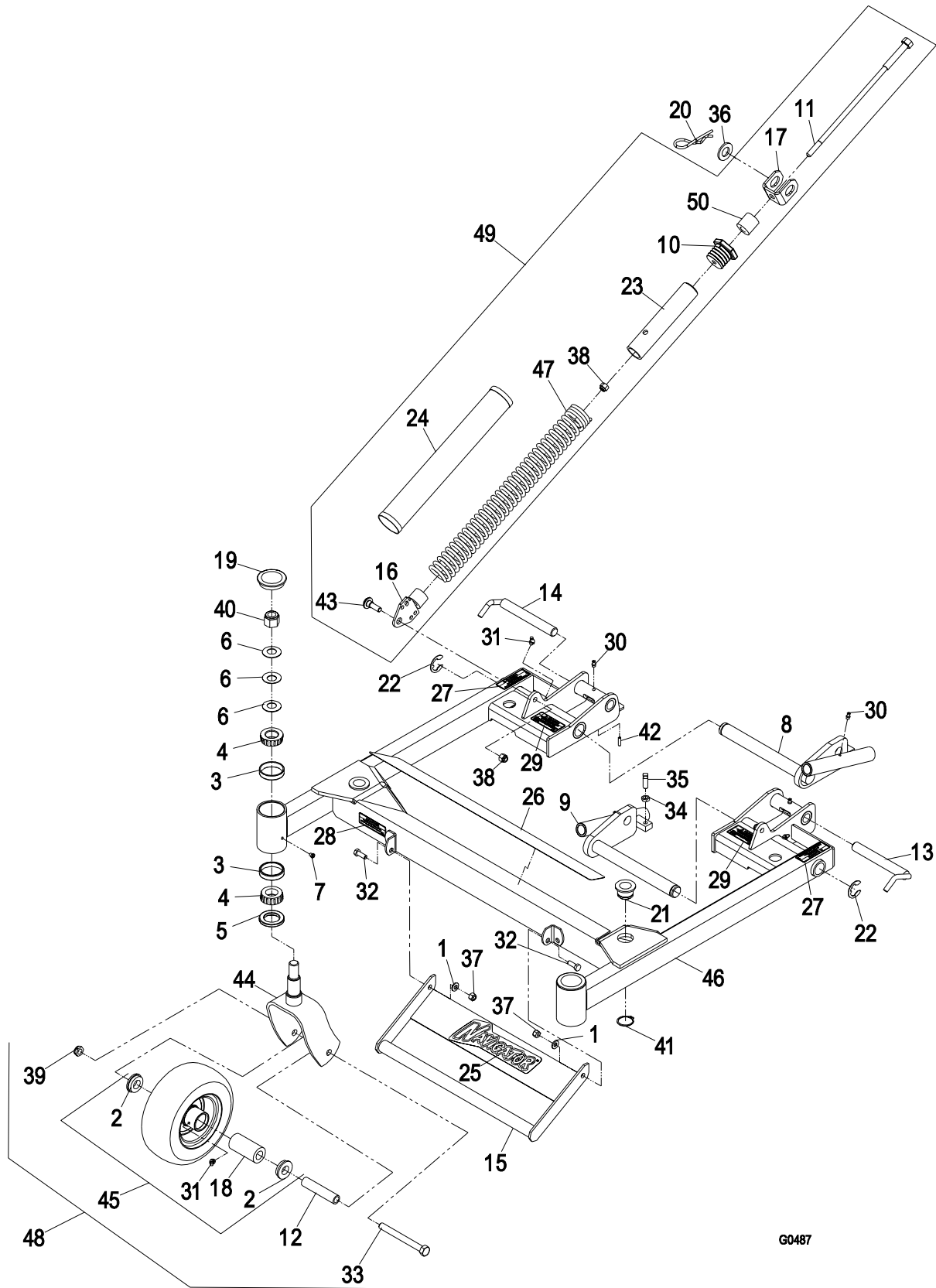

G0487

5.3 GEARBOX COMPONENTS FOR 103-3460 & 103-3387

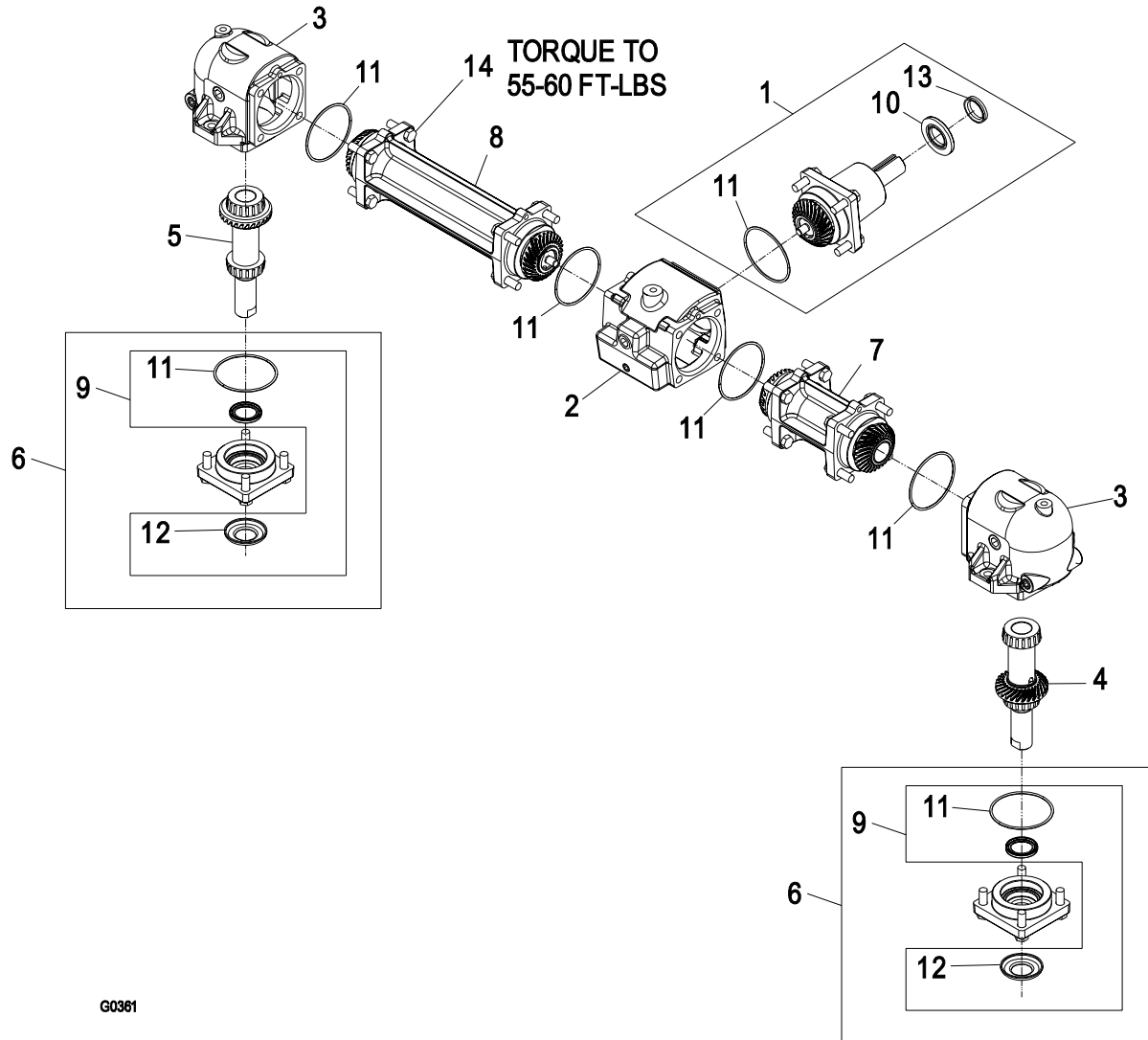

G0361

Item	Part No.	Description	Qty.
1	109-0188	Asm, Input Pinion 42".....	1
	109-0189	Asm, Input Pinion 48".....	1
2▲	109-0190	Center Housing W/Plugs.....	1
3▲	109-0191	End Housing W/Plugs & Race	2
4●	109-0192	Output Shaft, Gear & Brgs (42" LH)	1
●	109-0193	Output Shaft, Gear & Brgs (48" LH)	1
5●	109-0194	Output Shaft, Gear & Brgs (42" RH).....	1
●	109-0195	Output Shaft, Gear & Brgs (48" RH).....	1
6□	109-0196	Output Cap W/Race.....	2
7▲□	109-0197	Asm, Connector Tube 42" Short.....	1

Item	Part No.	Description	Qty.
▲	109-0198	Asm, Connector Tube 48" Short	1
8▲□	109-0199	Asm, Connector Tube 42" Long.....	1
▲	109-0200	Asm, Connector Tube 48" Long.....	1
9	109-0201	Kit, Output Seal	2
10+	109-0202	Seal, Input	1
11	109-0203	O-ring	7
12	109-0204	Washer, Cupped.....	1
13+	109-0205	V-ring.....	1
14	93-3987	Screw, HH 3/8-24 x 1 1/4 Gr8.....	28

Exmark red touch up paint (spray paint - P/N 1-850337 - .6 oz liquid bottle - P/N 103-9140).

Fill gearbox sections to drain/fill plug with Mobil SHC (synthetic) 75w-90 gear lube oil

▲ Includes o-rings, item #11

● Includes (1) output seal assembly, item #9

+ Apply bead of Mobil HTS grease (P/N 103-5217 1.5 oz packet) between seal, item #10 and v-ring, item #13.

□ Does not include screw, item #14.

6.

**2-Year Limited Warranty
Exmark Turf Equipment**

(For units purchased on or after October 1, 2004)

Conditions and Products Covered

Exmark Mfg. Co. Inc. and its affiliate, Exmark Warranty Company, pursuant to an agreement between them, jointly warrant on the terms and conditions herein, that we will repair, replace or adjust any part manufactured by Exmark and found by us (in the exercise of our reasonable discretion) to be defective in factory materials or workmanship for a period of two years.

This warranty applies to Exmark turf equipment purchased on or after October 1, 2004 sold in the US or Canada. This warranty may only be assigned or transferred to a second (or third) owner by an authorized Exmark dealer. The warranty period commences upon the date of the original retail purchase.

Products

Warranty Period

- | | |
|--|--|
| • All Products (except as noted below) | 2 years |
| • All Attachments and Accessories | 1 year |
| • Metro 21 and Metro 26 Series | 1 year |
| • Belts and Tires | 90 days |
| • Battery | 1 Year Prorated |
| • Engine* | Warranty is covered by engine manufacturer |

*Please refer to the engine manufacturer's warranty statement that is included in the literature packet. We are not authorized to handle warranty adjustments on engines.

This warranty only includes the cost of parts and labor.

Items and Conditions Not Covered

This warranty does not cover the following:

- Pickup and delivery charges to and from any authorized Exmark Service Dealer.
- Any damage or deterioration due to normal use, wear and tear, or exposure.
- Cost of regular maintenance service or parts, such as filters, fuel, lubricants, tune-up parts, and adjustments.
- Any product or part which has been altered or misused or required replacement or repair due to normal wear, accidents, or lack of proper maintenance.
- Any repairs necessary due to use of parts, accessories or supplies, including gasoline, oil or lubricants, incompatible with the turf equipment or other than as recommended in the operator's manual or other operational instructions provided by Exmark.

All warranty work must be performed by an authorized Exmark Service Dealer using Exmark approved replacement parts.

Instructions for Obtaining Warranty Service

1. Contact any Exmark Service Dealer to arrange service at their dealership. To locate a dealer convenient to you, access our website at www.exmark.com. U.S. Customers may also call 402-223-6375.
2. Bring the product and your proof of purchase (sales receipt) to the Exmark Service Dealer.

If for any reason you are dissatisfied with the Service Dealer's analysis or with the assistance provided, contact us at:

Exmark Customer Service Department
The Exmark Warranty Company
2101 Ashland Avenue
Beatrice, NE 68310
402-223-6375 or
service@exmark.com

Owner's Responsibilities

The Exmark turf equipment, including any defective part, must be returned to an authorized Exmark service dealer within the warranty period. This warranty extends only to turf equipment operated under normal conditions. You must properly service and maintain your Exmark product as described in the operator's manual. Such routine maintenance, whether performed by a dealer or by you, is at your expense.

As a condition to this warranty, customer shall have read the operator's manual and shall have completed and submitted to Exmark Warranty Company, within the prescribed time, the Exmark warranty registration.

General Conditions

The sole liability of Exmark and Exmark Warranty Company with respect to this warranty shall be repair and replacement as set forth herein. **Neither Exmark nor Exmark Warranty Company shall have any liability for any other cost, loss or damage, including but not limited to, any incidental or consequential loss or damage.**

In particular, we shall have no liability or responsibility for:

- Expenses related to gasoline, oil or lubricants.
- Travel time, overtime, after hours time or other extraordinary repair charges or charge relating to repairs or replacements outside of normal business hours at the place of business of the authorized Exmark service dealer.
- Rental of like or similar replacement equipment during the period of any warranty, repair or replacement work.
- Any telephone or telegram charges or travel charges.
- Loss or damage to person or property other than that covered by the terms of this warranty.
- Any claims for lost revenue, lost profit or additional cost as a result of a claim of breach of warranty.
- Attorney's fees.

No Claim of breach of warranty shall be cause for cancellation or rescission of the contract of sale of any Exmark mower.

There are no understandings, agreements, representations, or warranties, express or implied, including but not limited to any regarding the merchantability (that product is fit for ordinary use) or fitness for use (that product is fit for a particular purpose), not specified herein, respecting the equipment which is the subject of this warranty.

Some states do not allow exclusions of incidental or consequential damages, or limitations on how long an implied warranty lasts, so the above exclusions and limitations may not apply to you.

This warranty gives you specific legal rights, and you may also have other rights which vary from state to state.

NOTES

NOTES

SEE EXMARK'S COMPLETE LINE OF ACCESSORIES

RIDING ACCESSORIES

CUSTOM RIDE SEAT SUSPENSION SYSTEM
DECK LIFT ASSIST KIT
HITCH KIT
LIGHT KIT
MICRO-MULCH SYSTEM
ROLL OVER PROTECTION SYSTEM (ROPS)
SNOW BLADE
SUN SHADE
TRASH CONTAINER
TURF STRIPER
ULTRA VAC COLLECTION SYSTEM
ULTRA VAC QUICK DISPOSAL SYSTEM

WALK BEHIND ACCESSORIES

GRASS CATCHER
MICRO-MULCH SYSTEM
STEERABLE SULKY
SULKY HITCH KIT
TURF STRIPER
STANDON

Check us out on the Web:

www.exmark.com

© 2005-2006 EXMARK MFG. CO. INC.
INDUSTRIAL PARK BOX 808
BEATRICE, NE 68310

PART NO. 109-3928 Rev. A
(402) 223-6300
FAX (402) 223-5489

ALL RIGHTS RESERVED

PRINTED IN U.S.A.

