

For Serial Nos.
370,000 & Higher

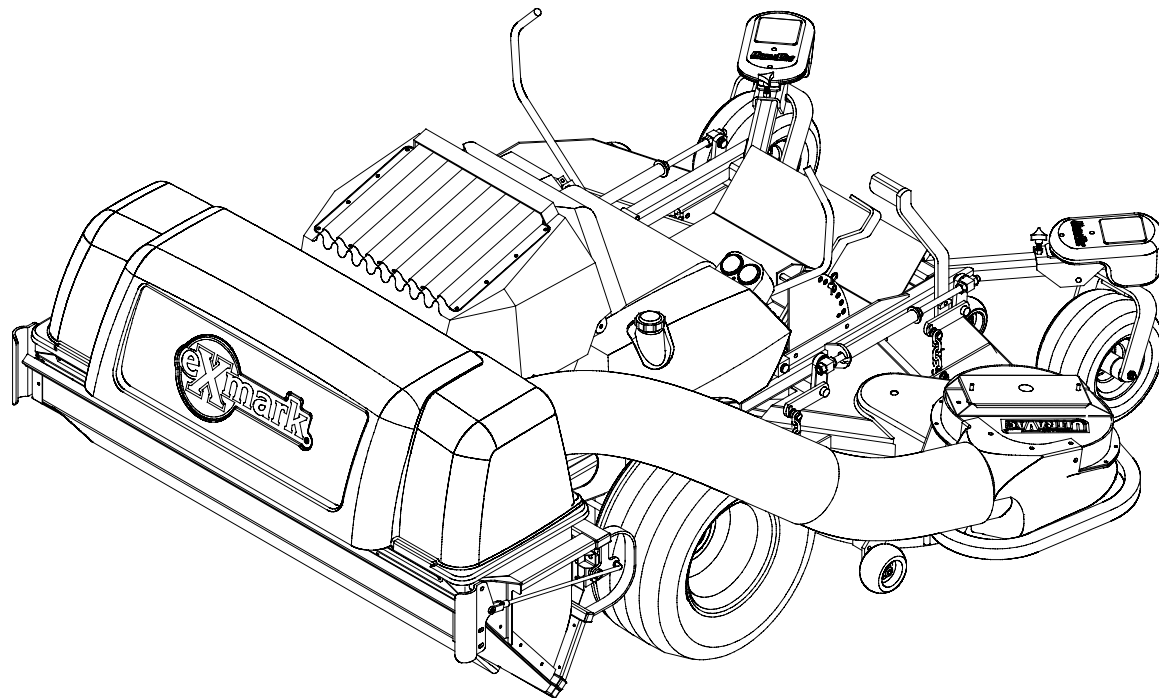

ULTRA VAC™ QDS

CONGRATULATIONS on the purchase of your new Exmark equipment. This product has been carefully designed and manufactured to give you a maximum amount of dependability and years of trouble-free operation. If additional information is needed, or should you require trained mechanic service, contact your authorized Exmark equipment dealer or distributor. If you need to order replacement parts from your dealer, always give the model number and serial number of your equipment as well as the part number, description and quantity of the part needed.

The Serial No. plate is located on the rear of the blower assembly. For ease of ordering and reference, we suggest that you record the information requested in the following identification table.

Place Model No. and Serial No. Label Here (Included in Literature Pack) or Fill in Below	
Model No.	_____
Serial No.	_____

Part No. 103-2716 Rev C

OPERATOR'S & PARTS MANUAL

 WARNING
POTENTIAL HAZARD <ul style="list-style-type: none">◆ This product is a piece of power equipment.
WHAT CAN HAPPEN <ul style="list-style-type: none">◆ Failure to follow safe operating practices can result in serious operator injury or even death.
HOW TO AVOID THE HAZARD <ul style="list-style-type: none">◆ Keep all shields, guards and safety devices (especially the grass discharge system) in place and in proper working condition.◆ Stop engine and wait for all moving parts to stop. Remove spark plug wire(s) or remove key before adjusting, servicing, or performing maintenance.◆ If mower deck becomes clogged, stop engine and wait for all moving parts to stop. Remove spark plug wire(s) or remove key before cleaning blockage.◆ Keep hands, feet and clothing away from power driven parts.◆ Keep off mower unless seat platform is provided.◆ Keep others off mower.

Exmark reserves the right to make changes or add improvements to its products at any time without incurring any obligation to make such changes to products manufactured previously. Exmark, or its distributors and dealers, accept no responsibility for variations which may be evident in the actual specifications of its products and the statements and descriptions contained in this publication.

EXMARK PARTS PLUS® PROGRAM

EFFECTIVE DATE: September 1, 1995

Program

If your Exmark dealer does not have the Exmark part in stock, Exmark will get the parts to the dealer the next business day or the part will be FREE* Guaranteed!!

How the Program Works

1. If dealer does not have part in stock for a "down" unit at the time of request by customer, the dealer contacts his distributor by 1:00 p.m., local time, and requests Exmark Parts Plus® shipment of six (6) line items or less.
2. Distributor ships part(s) to dealer or customer, as requested by dealer, same day, overnight UPS Distributor bills dealer for part and freight charges where applicable.
3. If distributor does not have the part(s) in stock to satisfy Exmark Parts Plus® order, he contacts Exmark by 3:00 p.m., central time, with an Exmark Parts Plus® order of six (6) line items or less.
4. If order is received by 3:00 p.m. central time, Exmark ships part(s) direct to dealer or customer, as requested by distributor, same day, overnight UPS Exmark bills the distributor for parts and shipping charges, where applicable.
5. The customer pays for the part and freight if it is shipped under the Exmark Parts Plus® and if it arrives in accordance to the program.
6. Who pays for the part and freight if it fails to arrive overnight in accordance to the program?
 - A. Under any circumstance the customer does not pay.
 - B. If the part does not arrive overnight due to:
 1. The dealer not submitting the Exmark Parts Plus® order to his Exmark distributor by 1:00 p.m., the dealer pays for the part and freight.
 2. The Distributor being unable to ship the part the same day or not submitting the Exmark Parts Plus® order to Exmark by 3:00 p.m., central time, the Distributor pays for the part and freight.
 3. Exmark being unable to ship the part and the Exmark parts order is received by 3:00 p.m., central time, Exmark pays for the part and freight.
 4. If the part does not arrive overnight due to the shipper (UPS), the shipper pays for the freight and Exmark pays for the part.

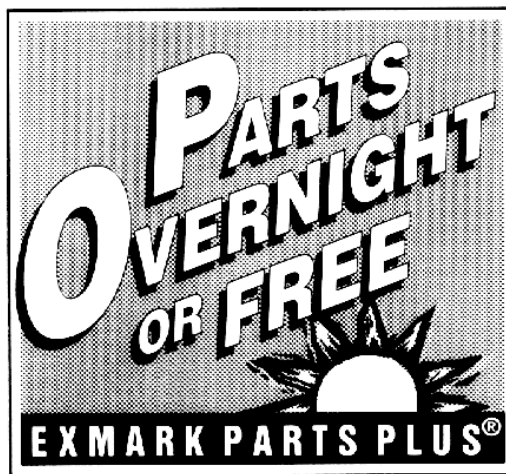

The following restrictions apply -- The Exmark Parts Plus® Program is available only through participating Exmark Dealers and applies only to orders submitted on this program Monday through Thursday. Parts Plus service is available only in the 48 contiguous United States. UPS has initiated a Saturday delivery program to many areas of the continental United States and can be requested for an overnight shipment on Friday to be delivered Saturday. The next day air charge, plus the Saturday delivery fee will be the responsibility of the purchaser. Exmark Mfg. will assume no responsibility for Saturday delivery shipments. To qualify, all Exmark Parts Plus® orders must be received by Exmark by 3:00 p.m., central time. Orders must be six (6) line items or less. Exclusions from the Exmark Parts Plus® Program are: Any wholegood or accessory in its entirety, engines and engine replacement parts, 5-speed Peerless transmissions and 5-speed transaxles, hydraulic or hydrostatic wheel motors, cutter decks and engine decks or any item exceeding United Parcel Service size and weight restrictions.

Due to UPS restrictions, aerosol spray paint is considered a hazardous material and cannot be shipped via UPS next day or Second Day Air.

Exmark Manufacturing stocks a limited supply of parts for transaxles, pumps and wheel motors. These parts can be ordered for Next Day Air shipment but will not be guaranteed per the Parts Plus Program.

OPERATOR'S MANUAL

This manual contains assembly, operating, maintenance, adjustment and safety instructions for your Exmark Ultra Vac QDS.

BEFORE OPERATING YOUR ULTRA VAC QDS, CAREFULLY READ AND UNDERSTAND THIS MANUAL AND THE OPERATOR'S MANUAL FOR YOUR MOWER IN THEIR ENTIRETY.

By following the operating, maintenance and safety instructions, you will prolong the life of your Ultra Vac QDS, maintain its maximum efficiency and promote safe operation.

If additional information is needed, or should you require trained mechanic service, contact your authorized Exmark equipment dealer or distributor.

All Exmark equipment dealers and distributors are kept informed of the latest methods of servicing and are equipped to provide prompt and efficient service in the field or at their service stations. They carry ample stock of service parts or can secure them promptly for you from the factory.

All Exmark parts are thoroughly tested and inspected before leaving the factory, however, attention is required on your part if you are to obtain the fullest measure of satisfaction and performance.

TABLE OF CONTENTS

<u>Description</u>	<u>Page</u>
1. Safety	
1.1 Safety Alert Symbol	6
1.2 Training	6
1.3 Preparation	6
1.4 Safety Signs.....	7
2. Assembly Instructions	
2.1 Assembly Diagram.....	8-9
2.2 Install Hood Assembly and Bags	9-11
2.3 Install Blower Assembly	11-13
2.4 Assemble Tubes	13
2.5 Install Weight Plates	13-14
2.6 Install Removable Weights	14
2.7 Adjustments	14-15
3. Operation	
3.1 Pre-Start	15-16
3.2 Mowing	16
3.3 Bagger Removal for Side Discharge	16-18
3.4 Transporting.....	18-19
4. Maintenance	
4.1 Adjustments	19
4.2 Periodic Maintenance	19-20
5. Specifications	
5.1 Model Number	20
5.2 Dimensions	21
5.3 Bagging System.....	21
6. Parts Lists	
6.1 Decals.....	22
6.2 Hitch Kit Assembly	23
6.3 Blower Assembly	24-25
6.4 Hood and Bag Assembly	26-27
6.5 Completing Kit Assembly	28-29
7. Warranty	30-31

1. SAFETY

1.1 SAFETY ALERT SYMBOL

This SAFETY ALERT SYMBOL  is used both in this manual and on the machine to identify important safety messages which must be followed to avoid accidents. This symbol means:

ATTENTION! BECOME ALERT! YOUR SAFETY IS INVOLVED!

The safety alert symbol appears above information which alerts you to unsafe actions or situations and will be followed by the word **DANGER**, **WARNING**, or **CAUTION**.

DANGER: White lettering/Red background. Indicates an imminently hazardous situation which, if not avoided, **WILL** result in death or serious injury.

WARNING: Black lettering/Orange background. Indicates a potentially hazardous situation which, if not avoided, **COULD** result in death or serious injury.

CAUTION: Black lettering/ Yellow background. Indicates a potentially hazardous situation which, if not avoided, **MAY** result in minor or moderate injury.

1.2 TRAINING

- 1.2.1 Regard the Exmark Ultra Vac QDS as a piece of power equipment and teach this regard to all who operate this unit.
- 1.2.2 Before operating your Ultra Vac QDS, carefully read and understand this manual and the operator's manual for your mower in their entirety. Familiarize yourself with the controls and the proper use of the equipment. If the operator(s) or mechanic(s) can not read English, it is the owner's responsibility to explain this material to them.
- 1.2.3 Do not allow operation of this machine by untrained personnel. Never allow children, teenagers, or people unfamiliar with these instructions to use the mower. Local regulations may restrict the age of the operator.
- 1.2.4 Avoid mowing while people, especially children, or pets, are nearby. Keep in mind that the operator or user is responsible for accidents or hazards occurring to other people or their property.

1.3 PREPARATION

- 1.3.1 Evaluate the terrain to determine what accessories and attachments are needed to properly and safely perform the job. Only use accessories and attachments approved by Exmark.
- 1.3.2 The use of personal protective equipment, such as (but not limited to) protection for the eyes, ears, feet, and head is recommended.

 CAUTION
POTENTIAL HAZARD <ul style="list-style-type: none">◆ This machine produces sound levels in excess of 85 dBA at the operator's ear when in operation.
WHAT CAN HAPPEN <ul style="list-style-type: none">◆ Exposure to sound levels of 85 dBA or above for extended periods of time can cause hearing loss.
HOW TO AVOID THE HAZARD <ul style="list-style-type: none">◆ Wear hearing protection when operating this machine.

- 1.3.3 While mowing, always wear substantial footwear and long trousers. Do not operate equipment when barefoot or when wearing open sandals.
- 1.3.4 Thoroughly inspect the area where the equipment is to be used and remove all stones, sticks, wires, bones, and other foreign objects which may damage the equipment or cause personal injury to the operator or bystanders.

1.4 SAFETY SIGNS

- 1.4.1 Keep all safety signs legible. Remove all grease, dirt and debris from safety signs and instructional labels.
- 1.4.2 Safety signs must be replaced if they are missing or illegible.
- 1.4.3 When new components are installed, be sure that current safety signs are affixed to the replaced components.
- 1.4.4 Replacement safety signs may be obtained from your authorized Exmark equipment dealer or distributor or from Exmark Mfg. Co. Inc.
- 1.4.5 Safety signs may be affixed by peeling off the backing to expose the adhesive surface. Apply only to a clean, dry surface. Smooth to remove any air bubbles.
- 1.4.6 Familiarize yourself with the following safety signs and instruction labels. They are critical to the safe operation of your Exmark Ultra Vac QDS.

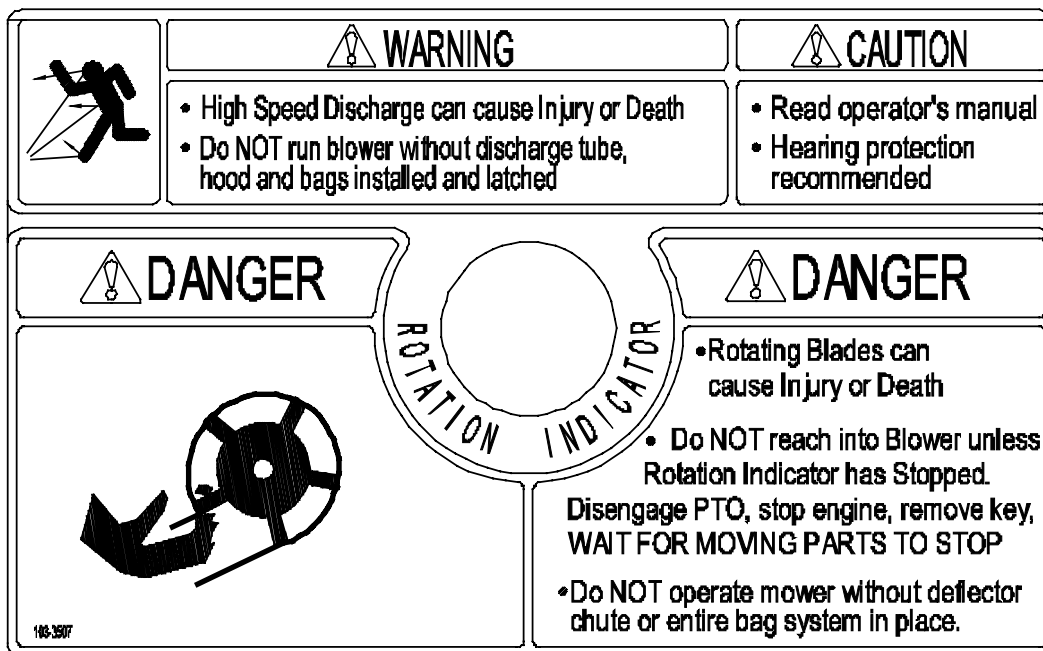

PART NO. 103-3507
LOCATION: Top of Blower



PART NO. 98-5954
LOCATION: Under Bearing Cover

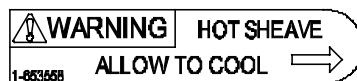

PART NO. 1-653558
LOCATION: Top of Idler Arm



PART NO. 1-653554
LOCATION: Rear of Bag



PART NO. 103-0878
LOCATION: Top of Weights & Top of Blower

2. ASSEMBLY INSTRUCTIONS – LAZER Z & LAZER Z XP**2.1 ASSEMBLY DIAGRAM**

Ref. No.	Description	Qty (60 / 72 LZ)	Qty (60 / 72 XP)
1	Hopper Assembly	1	1
2	Upper Tube	1	1
3	Lower Tube	1	1
4	#10-24 X .75 Screw	3 / 6	3 / 6
5	#10-24 Nyloc Nut	3 / 6	3 / 6
6	#10 Flat Washer	3 / 6	3 / 6
7	Handle Assembly	1	1
8	Blower Assembly	1	1
9	Bagger Mount Weldment	1	1
10	Belt Cover	1	1
11	Removable Weight	2	2
12	Jackshaft	1	1
13	Blower Drive Belt	1	1
14	Frame Bracket RH	1	
15	Frame Bracket LH	1	
16	Frame Bracket XP		2
17	XP Mount Spacer		2
18	Mount Pin Weldment	1	1
19	Clevis Pin	4	4
20	Hair Pin (large)	4	4
21	Chute Pivot Pin	1	1
22	Hair Pin (small)	1	1
23	3/8-16 x 1.00 Hex Screw	14	16
24	3/8 Whizlock Nut	21	23
25	3/8 Spring Disk Washer	14	16
26	XP Handle Mount		1
27	Belt Shield Stud	1	1
28	3/8-16 x .75 Hex Screw	3	3
29	Belt Cover Spacer	1 – 60 only	1 – 60 only
30	7/16 Spring Disk Washer	2 – 60 only	2 – 60 only
31	Washer – ¼ thick	2 – 60 only	
32	3/8-16x3.25 Tap Bolt	2 – 60 only	
33	Weight Bracket	2	2
34	3/8-16 Square Head Bolt	4	4
35	Weight Plate	5	5
36	5/16-18 x 1.75 Hex Screw	4	4
37	5/16 Flat Washer	4	4
38	5/16-18 Whizlock nut	4	4
39	Plug	1	1

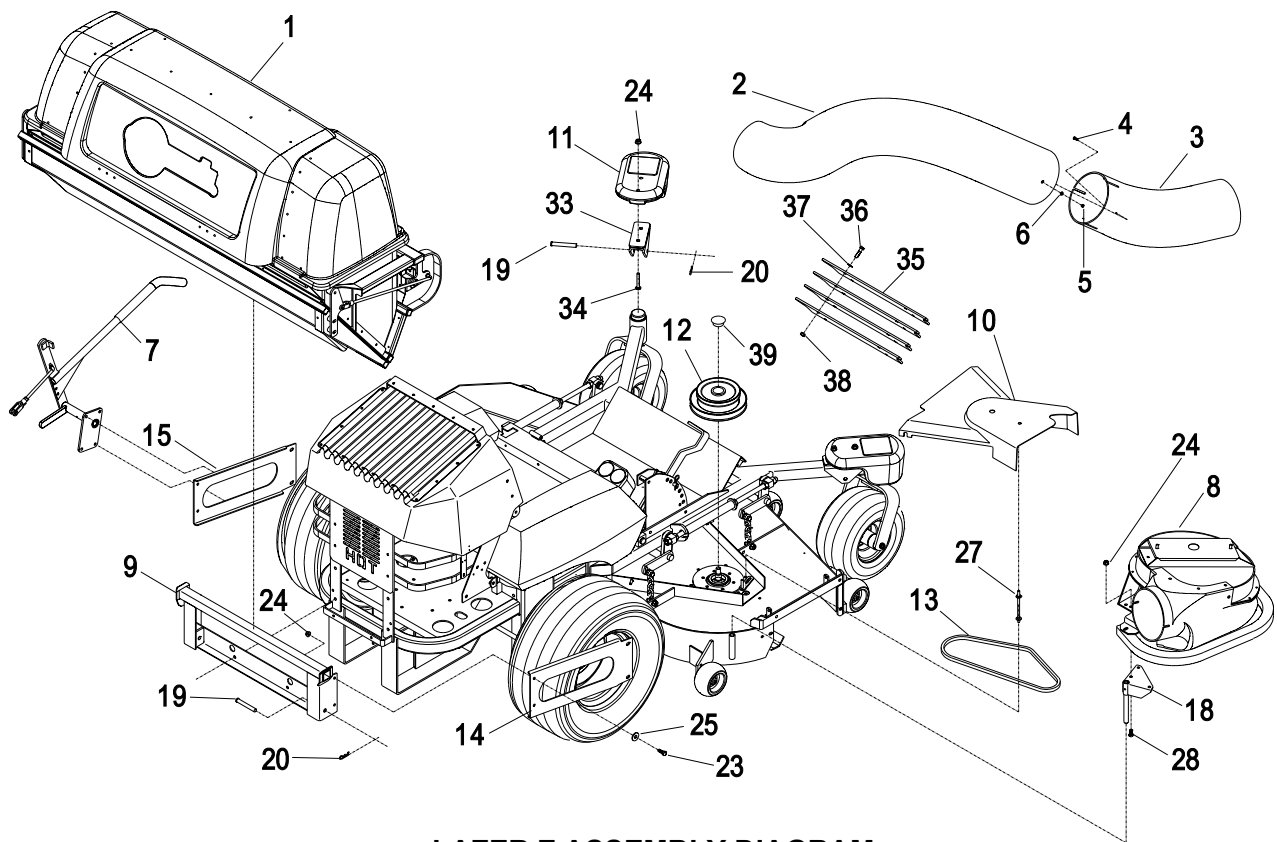

LAZER Z ASSEMBLY DIAGRAM

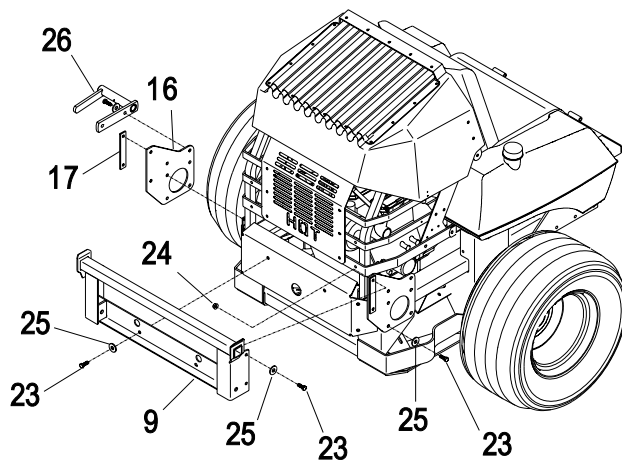

LAZER Z XP ASSEMBLY DIAGRAM

Items 21,22, 29, 30, 31 and 32 not shown. See figure 1 for installation of 31 and 32. See figure 5 for installation of 29 and 30. See figure 8 for installation of 21 and 22.

2.2 INSTALL THE HOPPER ASSEMBLY

Lazer Z units only (Lazer Z XP units skip to section 2.2.7)

2.2.1 When installing the Ultra Vac QDS onto a liquid cooled Lazer Z, the rear bumper plate must be removed. Remove rear bumper plate. Use two of the original screws, washers and whizlock nuts to attach the lower side bumper bars to the vertical "HOT" engine guard shield.

2.2.2 Remove the lower two screws holding the rear engine guard ("HOT" engine guard on liquid cooled units) to the rear frame of the Lazer Z unit. Units with serial numbers 159,999 and below will require disassembly of the clutch strap spacers to remove these screws.

2.2.3 On units with serial numbers 190,000 and higher install the mount weldment (Item 9) loosely to the rear of the machine using the two screws and nuts removed in section 2.2.2.

For units with serial numbers 189,999 and below, install washers (Item 31) between the bagger mount weldment and clutch guard when installing the bagger mount weldment. This will provide for proper alignment of the mount holes with the holes in the hopper assembly. See figure 1.

For units with serial numbers 159,999 and below, remove the two tap bolts that tie the clutch straps to the rear engine guard and replace with new tap bolts (Item 32). These units also require the use of the washers (Item 31) between the bagger mount weldment and the rear engine guard. These parts should be installed when the bagger mount weldment is installed on the rear of the unit. See figure 1.

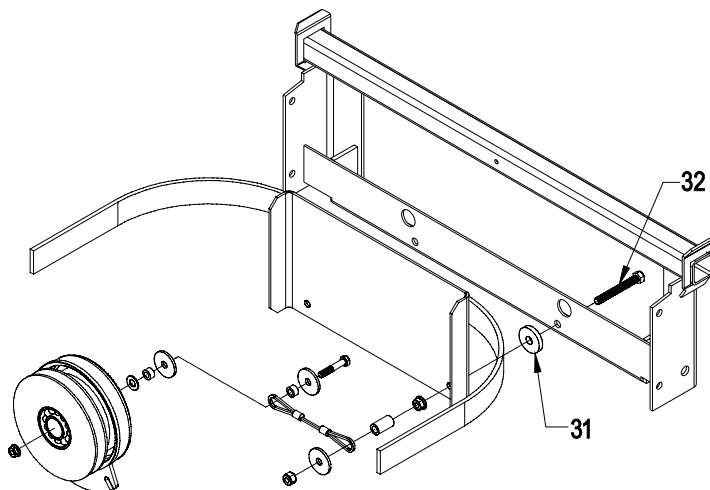



FIGURE 1

2.2.4 Jack the rear of the unit up and safely support it on jack stands. Remove the rear wheels.

 CAUTION	
POTENTIAL HAZARD	◆ Relying solely on mechanical or hydraulic jacks to support the mower could be dangerous.
WHAT CAN HAPPEN	◆ The mechanical or hydraulic jacks may not be enough support or may malfunction allowing the unit to fall, which could cause injury.
HOW TO AVOID THE HAZARD	◆ DO NOT rely solely on mechanical or hydraulic jacks for support. Use adequate jack stands or equivalent support.

2.2.5 Mount the handle assembly (Item 7) onto left hand frame bracket (Item 15) using 3/8-16 x 1.00 screws (Item 23), 3/8 spring disk washers (Item 25) and 3/8-16 whizlock nuts (Item 24). Make sure that the raised portion of the spring disk washer faces the head of the bolt.

- 2.2.6 Install the right and left hand frame brackets (Items 14 and 15) loosely to the mount weldment and the wheel channels of the Lazer Z frame. The flanges on the right and left hand frame brackets should face in towards the unit to provide the maximum tire clearance. Use the 3/8-16 x 1.00 screws (Item 23), 3/8 spring disk washers (Item 25) and 3/8-16 whizlock nuts (Item 24). Make sure that the raised portion of the spring disk washer faces the head of the bolt. On 60 inch units, the lower bolt on the wheel channel is best installed by positioning the nut behind the hole using a deep socket and turning the bolt through the hole into the nut.

Lazer Z XP units only (Lazer Z units continue at section 2.2.11)

- 2.2.7 Install mount weldment (Item 9) loosely to the rear bumper using the two holes provided. Use the 3/8-16 x 1.00 screws (Item 23), 3/8 spring disk washers (Item 25) and 3/8-16 whizlock nuts (Item 24).
- 2.2.8 Attach the XP handle mount (Item 26) onto frame bracket (Item 16) using 3/8-16 x 1.00 screws (Item 23), 3/8 spring disk washers (Item 25) and 3/8-16 whizlock nuts (Item 24). Make sure that the raised portion of the spring disk washer faces the head of the screw.
- 2.2.9 Remove the E-clip and handle from the handle assembly (Item 7). Discard the mount that came with the handle assembly. Install the handle and E-clip onto the XP handle mount that came in the completing kit.
- 2.2.10 Install the frame brackets (Item 16) and spacers (Item 17) loosely to the mount weldment and the mounting pads on the Lazer Z XP frame. Use the 3/8-16 x 1.00 screws (Item 23), 3/8 spring disk washers (Item 25) and 3/8-16 whizlock nuts (Item 24). Make sure that the raised portion of the spring disk washer faces the head of the screw.

All Units

- 2.2.11 Tighten all the hardware, starting with the screws that hold the mount weldment to the rear of the unit and working forward.
- 2.2.12 On Lazer Z units, reinstall the rear wheels and lower the unit from the jack stands.
- 2.2.13 Apply a light coat of grease to the front and rear of the upper tube of the mount weldment. Install the hopper assembly (Item 7) onto the mount by slipping the hook portion over the top mounting tube of the mount weldment. Secure the assembly to the mount using the clevis pins (Item 19) and hairpins (Item 20).
- 2.2.14 Attach the handle link to the actuation arm on the hopper assembly.

2.3 INSTALL BLOWER ASSEMBLY

- 2.3.1 Lower the deck fully. Remove the right hand belt cover. Remove the belt cover mounting stud that protrudes from the deck.
- 2.3.2 Remove the deck drive belt from around the right hand spindle sheave.
- 2.3.3 Support the right mower blade and shaft so that it will not fall out of the deck when the right sheave nut is removed.
- 2.3.4 Remove the right sheave nut, spring disk washer, and sheave from the spindle shaft.

NOTE: On units with wrench flats on the spindle just above the blade use a 1-inch wrench on the flat sides of the spindle shaft to prevent the spindle from turning. On units that do not have a wrench flat, block the blade rotation with a block of wood between the blade and baffles as indicated in the blade service section of the Lazer operator's manual. Do not use the blade bolt to prevent rotation.

On units with serial numbers below 352,000 replace the spindle shaft at this point with the shaft included in the spindle kit.

- 2.3.5 Apply a light coat of Mobile HTS grease (or food grade antisieze) to the top portion of the spindle shaft where the sheave mounts.
- 2.3.6 Install the jackshaft (Item 12) onto the right spindle shaft. Install the spring disk washer and nut. Torque the sheave nut to 140-145 ft. lbs. Make sure that the spring disk washer cone is installed towards nut. See Figure 2.

NOTE: On units with wrench flats on the spindle just above the blade use a 1-inch wrench on the flat sides of the spindle shaft to prevent the spindle from turning. On units that do not have a wrench flat, block the blade rotation with a block of wood between the blade and baffles as indicated in the blade service section of the Lazer Z operator's manual. Do not use the blade bolt to prevent rotation. Check blade bolt torque after completing this installation (115 – 120 ft. lbs.).

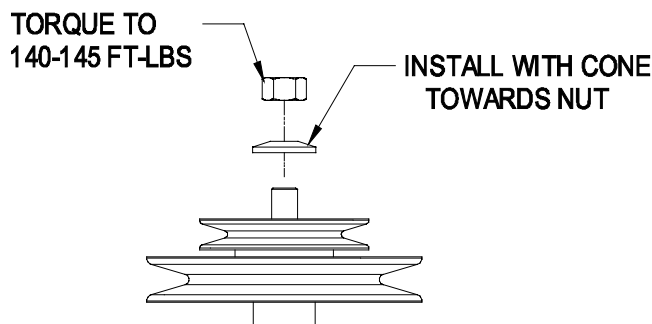

FIGURE 2

- 2.3.7 Re-install the deck drive belt in the lower groove of the double sheave. Install the plug (Item 24) into the bore of the double sheave.
- 2.3.8 Remove the discharge chute from the deck. Discard the mounting hardware, but save the discharge chute for use during side discharge operation. The chute pivot pin (Item 21) and hairpin (Item 22) may be stored in the pivot holes on the discharge chute during bagging operation.
- 2.3.9 Install the belt cover mounting stud (Item 27) included in the Ultra Vac QDS completing kit.

For 60 inch units only, install the spacer (Item 29), two 7/16 spring disk washers (Item 30) and the plastic knob as shown in Figure 3. The knob does not need to be tightened against the washers at this time.

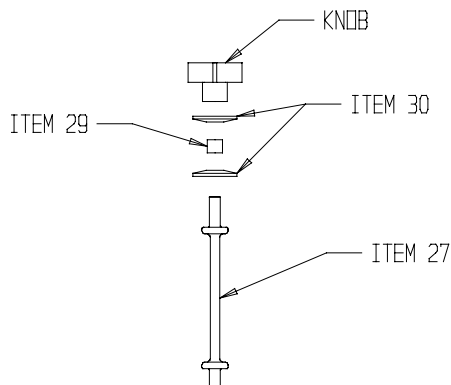

FIGURE 3

- 2.3.10 Install the mounting pin weldment (Item 18) to the blower assembly using the 3/8-16 x .75 screws (Item 28) and whizlock nuts (Item 24). Maximum deck clearance will be provided if the bolts are installed from below the mounting pin. The mount pin can be installed in two positions. For 60 inch decks the pin should be installed as far away from the bumper end as possible. For 72 inch decks that pin should be installed close to the bumper end.
- 2.3.11 Install the belt (Item 13) onto the blower by working it around the impeller sheave.
- 2.3.12 72" units serial number 259,999 and below will require the deck to be modified by adding the accessory mounting tube. Exmark kit 103-0583 contains the parts and templates required. Follow the instructions in this kit. These decks will also require drilling the hole at the front upper corner of the discharge opening to 1/2 inch diameter. (See Figure 4). Touch up with red paint Exmark P/N 1-850337.

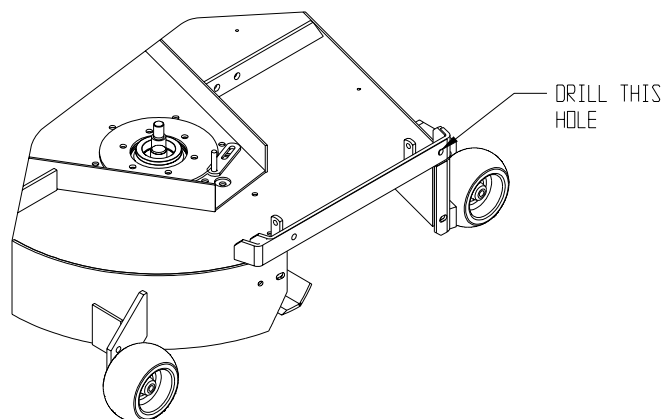

FIGURE 4

- 2.3.13 Mount the blower on the deck by sliding the mounting pin into the tube at the rear right corner of the deck. Swing the blower closed. Adjust the position of the front pin to engage the slot in the front of the deck. Use the latch to lock the blower in this position. Adjust the tension on the latch to draw the blower up to the deck, yet allow for release by hand.
- 2.3.14 Pull the spring loaded idler back and slip the belt over the top sheave on the deck spindle.
- 2.3.15 Install the plastic belt cover (Item 10). On 60" units the outside end of the cover is slotted and can slip between the two washers assembled in step 2.3.9. The plastic knob does not need to be removed. On 72" units the cover has a hole, and the plastic knob must be installed after the cover has been positioned.

2.4 ASSEMBLE THE TUBES

- 2.4.1 Remove the screws, nuts, and washers (Items 4,5,and 6) from the lower tube (Item 3) and slide the lower and upper tube (Item 2) together. The arrow on the upper tube should align with the dimple on the lower tube. There are two sets of holes on the lower tube. The first set reached is for use with Lazer XP units. The second set reached is for Lazer Z units. Align the arrow on the upper tube with the dimple on the lower tube and slide them together until the proper set of holes is reached.
- 2.4.2 Fasten the upper and lower tubes together using three of the hardware sets removed from the lower tube in step 2.4.1. The heads of the screws must be inside the tube to prevent accumulation of grass inside the tube. The washer and the nut should be installed on the outside of the tube. Use the remaining three hardware sets to plug the exposed holes in the lower tube. On 60 " Lazer Z units, discard the remaining hardware sets.
- 2.4.3 Slip the upper end of the tube assembly into the hopper opening. Slide the lower end of the tube assembly over the blower outlet and align the notch with the tube latch. Latch the tube to the blower.

2.5 INSTALL THE WEIGHT PLATES

- 2.5.1 Four of the weight plates (Item 35) must be installed under the front panel of the floor pan. One of the weight plates must be mounted on top of the front panel of the floor pan. These weights give proper balance to the machine when the mount and handle are installed and the blower, hopper, and tubes are removed for side discharge operation.
- 2.5.2 Locate the position of the mounting holes. Holes should be located by clamping a weight plate to the front of the floor pan (See Figure 5). The ears on the weight plate should be towards the bottom (upside down from the actual mounted position). Align the bottom edge of the weight plate with the bottom edge of the floor pan front panel. Center the weight plate side to side. On some machines hole positions are indicated by tool marks on the floor pan. Mark the position of all four holes using a center punch.
- 2.5.3 Drill 3/8 inch holes at the points marked.

- 2.5.4 Open the floor pan and install four weight plates behind the front panel, and one weight plate in front of the panel using the 5/16-18 x 1.75 screws, 5/16 washers and 5/16-18 whizlock nuts (Items 36, 37, and 38). The weight plates will only fit with the ears located near the bend in the floor pan. Apply the decal included in the literature pack to the center of the weight plate that was mounted to the top of the floor pan.

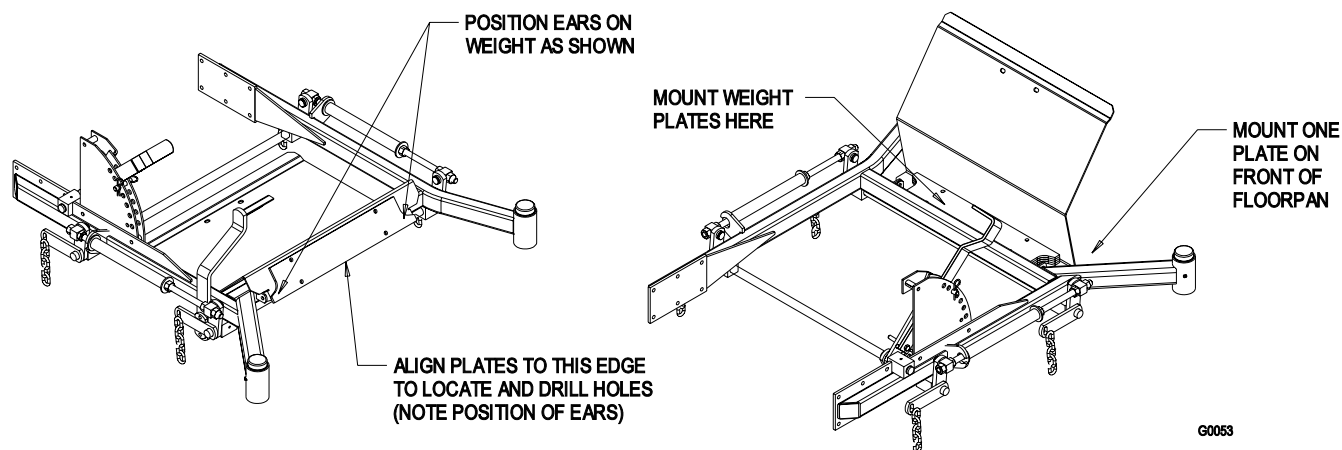
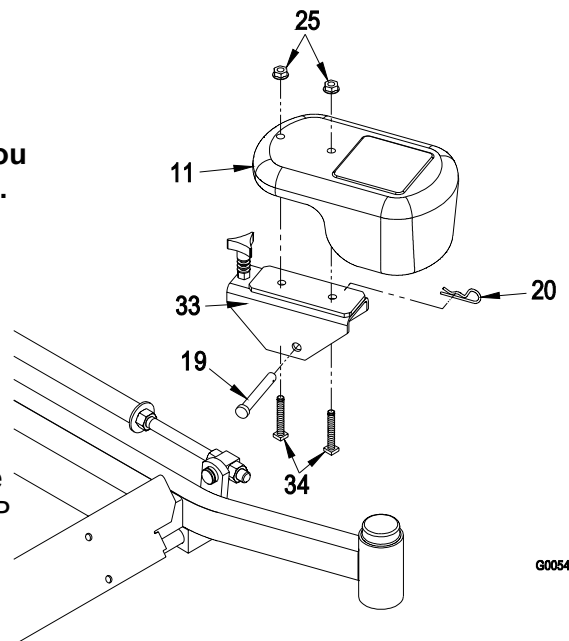

**FIGURE 5
FLOORPAN WEIGHT INSTALLATION**

2.6 INSTALL THE REMOVABLE WEIGHTS

Note: The removable weights are heavy. Use care when lifting them. Make sure that you can hold them securely before lifting them. Use caution when positioning your hands so that you do not set them down on your hands or fingers.

- 2.6.1 Assemble the weight brackets (Item 33) to the removable weights (Item 11) using the 3/8-16 square head bolts (Item 34) and 3/8 whizlock nuts (Item 25).
- 2.6.2 Install the removable weight assemblies over the caster arms. On 60 inch Lazer Z machines one weight has a wide mounting bracket and one has a narrow bracket. They will only fit the machine one way. Weights for the 60 Lazer XP and all 72's are interchangeable left and right.
- 2.6.3 Install a clevis pin (Item 19) and hairpin (Item 20) on each caster weight to retain them.
- 2.6.4 Tighten knob on weight assembly until the weight is clamped securely to the caster arm.



**FIGURE 6
REMOVABLE WEIGHT
INSTALLATION**

2.7 Adjustments:

Your Ultra Vac QDS was adjusted at the factory to operate properly. However, there are three basic adjustments that can be made, should your unit require them:

- 2.7.1 **Door closing:** The closing of the door is controlled by the two hinge links (Figure 7 – A) and the two stop screws (Figure 7 – B). The stop screws should be adjusted so that both will be contacted when the contacting arm is straight up and down. With the stop screws adjusted, the length of the hinge links can be changed to provide complete closing of the door, and reasonable force on the handle to latch or unlatch the door. Lengthen the links to reduce the force. Shorten the links to increase the force. With the door closed, both links should be slightly tight to minimize rattling.

- 2.7.2 **Door opening:** After adjusting the hinge links for door closing, the handle link (Figure 7 – C) can be adjusted to obtain maximum door opening. Lengthen the link to open the door farther. Shorten the link to open the door less. The maximum door opening is limited by the contacting arm hitting the stop (Figure 7 – D). This stop is non adjustable, and prevents over opening damage from occurring to the linkage.
- 2.7.3 **Latches:** Once the open and closed positions have been set, the latches (Figure 7 – E) can be adjusted. With the door closed, the latch link should be set so that the latch plate completely engages and contacts the latch rod welded to the door. The latch plates should not be tight against the latch rod. They should easily “wobble”.

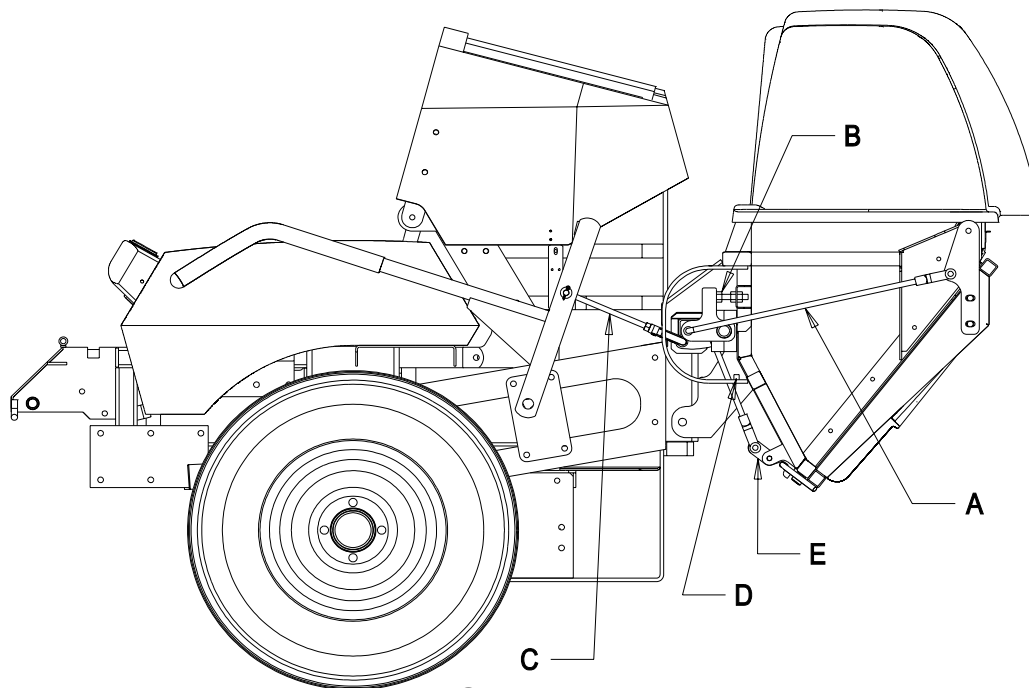

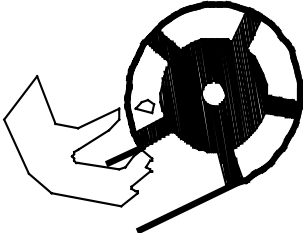
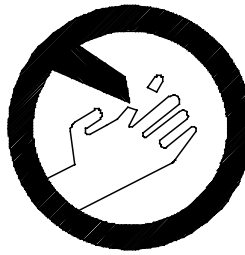

FIGURE 7

3. OPERATION:

Although hazard control and accident prevention are partially dependent upon the design and configuration of the equipment, these factors are also dependent upon the awareness, concern, prudence, and proper training of the personnel involved in the operation, transport, maintenance, and storage of the equipment. It is essential that all Operator Safety Mechanisms be connected and in operating condition prior to use for mowing. Refer to the Operator's Manual for the mower for additional hazard control and accident prevention information.

 WARNING	
POTENTIAL HAZARD	◆ An uncovered discharge opening will allow objects to be thrown in operator's or bystander's direction. Also, contact with blade could occur.
WHAT CAN HAPPEN	◆ Thrown objects or blade contact can cause serious injury or kill you or bystanders.
HOW TO AVOID THE HAZARD	◆ Never operate mower unless discharge chute or entire grass collection system is installed.

 DANGER		
	POTENTIAL HAZARD <ul style="list-style-type: none"> ◆ There are rotating blades in the blower and under the mower deck. 	
	WHAT CAN HAPPEN <ul style="list-style-type: none"> ◆ Blade contact can cause serious operator or bystander injury or even death. 	
	HOW TO AVOID THE HAZARD <ul style="list-style-type: none"> ◆ Do NOT reach into Blower unless Rotation Indicator has Stopped. Disengage PTO, stop engine, remove key, WAIT FOR MOVING PARTS TO STOP ◆ Do NOT operate mower without deflector chute or entire bag system in place. 	

3.1 PRE-START

Note: When mowing in areas with sandy soil, use low lift blades on the cutting deck and higher cutting heights to minimize wear on the blower components.

- 3.1.1 Read the operator's manual for your mower and familiarize yourself with all controls before operating the machine. Make sure that you understand the controls, their locations, their functions, and their safety requirements.
- 3.1.2 Ensure the blower, belt cover, door mesh, tube and hopper are in good condition, properly attached, and latched.

3.2 MOWING

- 3.2.1 The Ultra Vac QDS blower operates when deck drive is engaged. Be sure that **all** persons are **clear** of the mower deck **before engaging** the cutting blades. Set the throttle to "midway" position. Pull outward on the PTO switch to the "ROTATE" position. Accelerate to full throttle to begin mowing.
- 3.2.2 To disengage the PTO and blower, set the throttle to "idle" position. Push in on the PTO switch to the "STOP" position to stop the cutting blades and blower. The cutting blades will require a slightly longer amount of time to come to a complete stop when the blower is installed on the deck. Verify that all rotation indicators have stopped before clearing blower assembly or mower deck
- 3.2.3 To empty the hopper, first shut off deck drive. Lift up on the handle to open the door and empty the hopper. **If the unit is to be driven onto a truck or trailer with the hopper full, always back the unit up the ramp. This will reduce the chance of rearward tip up.**
- 3.2.4 Close and latch the door before continuing mowing. **Do not engage the cutting blades while the door is in the open position.**

3.3 BAGGER REMOVAL FOR SIDE DISCHARGE:

- 3.3.1 Disengage the PTO, stop engine and wait for all moving parts to stop. Remove spark plug wire(s) or remove key.
- 3.3.2 Remove the discharge tube by releasing the latch at the blower. Slide the tube off the blower outlet and remove the upper end from the hopper.
- 3.3.3 Remove the Belt cover by loosening the knobs. For 60" units the outboard knob does not need to be removed completely to remove the belt cover.

 CAUTION	
POTENTIAL HAZARD	◆ The deck sheave will become very hot
WHAT CAN HAPPEN	◆ Touching a hot deck sheave can cause severe burns.
HOW TO AVOID THE HAZARD	◆ Allow the deck sheave to cool completely before removing the belt.

- 3.3.4 Pull the idler release handle and remove the belt from the upper groove of the deck sheave.
- 3.3.5 Unlatch the front end of the blower. Pivot the blower back and lift it off the deck.
- 3.3.6 Install the discharge chute using the chute pivot pin and hairpin (See Figure 8).

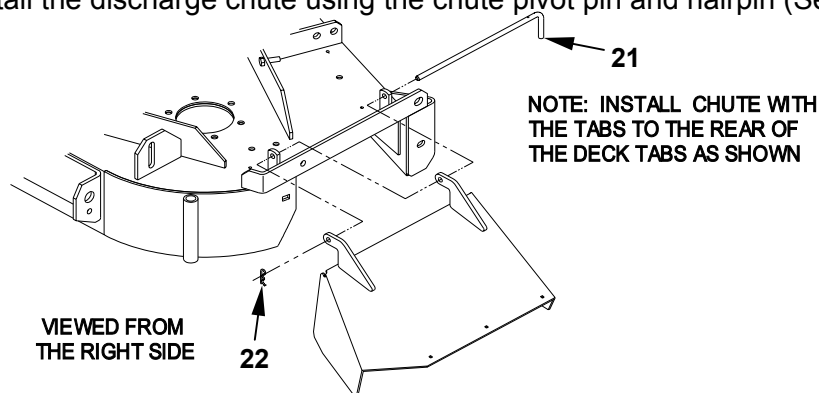



FIGURE 8
DISCHARGE CHUTE INSTALLATION

- 3.3.7 Re-install the plastic belt cover and tighten the knobs.
- 3.3.8 Disconnect the handle link from the actuation arm on the hopper. Connect the link to the arm on the handle mount for storage during side discharge operation.
- 3.3.9 Remove the hair pins and clevis pins holding the hopper assembly to the mount weldment.
- 3.3.10 Lift the hopper assembly off the mount.
- 3.3.11 The removable weights must be removed from above the caster wheels. Loosen the clamping knobs until the weight can be moved relative to the caster arm. Remove the hairpins and clevis pins that hold the weights to the caster arms. Carefully lift the weights off of the caster arms. The weights attached to the floorpan remain on the unit.

Note: The removable weights are heavy. Use care when lifting them. Make sure that you can hold them securely before lifting them. Use caution when positioning your hands so that you do not set them down on your hands or fingers.

Note: The portions of the Ultra Vac QDS bagger that are not bolted to the mower are designed to be installed or removed in their entirety. Do not operate the mower with only a portion of the Ultra Vac QDS installed.

 CAUTION
POTENTIAL HAZARD <ul style="list-style-type: none"> ◆ Caster weights installed without bagger may cause Loss of Traction and Steering control.
WHAT CAN HAPPEN <ul style="list-style-type: none"> ◆ Loss of control can result in an accident, which may cause Death, Injury, or property damage.
HOW TO AVOID THE HAZARD <ul style="list-style-type: none"> ◆ Install caster weights ONLY when bagger is installed.

3.3.12 The machine can now be used for side discharge mowing.

3.4 TRANSPORTING

3.4.1 Transporting a Unit: Use a heavy-duty trailer or truck to transport the machine. Lock brake and block wheels. Securely fasten the machine to the trailer or truck with straps, chains, cable, or ropes. Be sure that the trailer or truck has all necessary lighting and marking as required by law. Secure a trailer with a safety chain.

 CAUTION
POTENTIAL HAZARD <ul style="list-style-type: none"> ◆ This unit does not have proper turn signals, lights, reflective markings, or a slow moving vehicle emblem. These items are required to drive on a public street or roadway.
WHAT CAN HAPPEN <ul style="list-style-type: none"> ◆ Driving on a street or roadway without such equipment is dangerous and can lead to accidents causing personal injury. ◆ Driving on a street or roadway without such equipment may also be a violation of State laws and the operator may be subject to traffic tickets and/or fines.
HOW TO AVOID THE HAZARD <ul style="list-style-type: none"> ◆ Do not drive a unit on a public street or roadway.

 WARNING
POTENTIAL HAZARD <ul style="list-style-type: none"> ◆ Loading a unit on a trailer or truck increases the possibility of backward tip-over.
WHAT CAN HAPPEN <ul style="list-style-type: none"> ◆ Backward tip-over of the unit could cause serious injury or death.
HOW TO AVOID THE HAZARD <ul style="list-style-type: none"> ◆ Use extreme caution when operating a unit on a ramp. ◆ Use only a single, full width ramp; DO NOT use individual ramps for each side of the unit. ◆ If individual ramps must be used, use enough ramps to create an unbroken ramp surface wider than the unit. ◆ DO NOT exceed a 15° angle between ramp and ground or between ramp and trailer or truck. ◆ Avoid sudden acceleration while driving unit up a ramp to avoid tipping backward. ◆ Avoid sudden deceleration while backing unit down a ramp to avoid tipping backward.

- 3.4.2 **Loading a Unit:** **If the unit is to be driven onto a truck or trailer with the hopper full, always back the unit up the ramp. This will reduce the chance of rearward tip up.** Use extreme caution when loading units on trailers or trucks. One full width ramp that is wide enough to extend beyond the rear tires is required instead of individual ramps for each side of the unit. The lower rear section of the tractor frame extends back between the rear wheels and serves as a stop for tipping backward. Having a full width ramp provides a surface for the frame members to contact if the unit starts to tip backward. If it is not possible to use one full width ramp, use enough individual ramps to simulate a full width continuous ramp.

Ramp should be long enough so that the angles between the ramp and the ground and the ramp and the trailer or truck do not exceed 15°. A steeper angle may cause mower deck components to get caught as the unit moves from ramp to trailer or truck. Steeper angles may also cause the unit to tip backward. If loading on or near a slope, position the trailer or truck so it is on the down side of the slope and the ramp extends up the slope. This will minimize the ramp angle. The trailer or truck should be as level as possible.

DO NOT attempt to turn the unit while on the ramp, you may lose control and drive off the side.

Avoid sudden acceleration when driving up a ramp and sudden deceleration when backing down a ramp. Both maneuvers can cause the unit to tip backward.

Do not transport the unit with the hopper full.

4. MAINTENANCE:

4.1 ADJUSTMENTS

Your Ultra Vac QDS was adjusted at the factory to operate properly. However, there are three basic adjustments that can be made, should your unit require them:

Door closing: The closing of the door is controlled by the two hinge links (Figure 7 – A) and the two stop screws (Figure 7 – B). The stop screws should be adjusted so that both will be contacted when the contacting arm is straight up and down. With the stop screws adjusted, the length of the hinge links can be changed to provide complete closing of the door, and reasonable force on the handle to latch or unlatch the door. Lengthen the links to reduce the force. Shorten the links to increase the force. With the door closed, both links should be slightly tight to minimize rattling.

Door opening: After adjusting the hinge links for door closing, the handle link (Figure 7 – C) can be adjusted to obtain maximum door opening. Lengthen the link to open the door farther. Shorten the link to open the door less. The maximum door opening is limited by the contacting arm hitting the stop (Figure 7 – D). This stop is non adjustable, and prevents over opening damage from occurring to the linkage.

Latches: Once the open and closed positions have been set, the latches (Figure 7 – E) can be adjusted. With the door closed, the latch link should be set so that the latch plate completely engages and contacts the latch rod welded to the door. The latch plates should not be tight against the latch rod. They should easily “wiggle”.

4.2 PERIODIC MAINTENANCE

IMPORTANT: **Before conducting any maintenance, Disengage the PTO, stop engine and wait for all moving parts to stop. Remove spark plug wire(s) or remove key.**

- 4.2.1 Blower Housing/Impeller **Service Interval: Daily.**

Inspect for wear or damage daily. Replace or repair worn parts as needed.

Note: When mowing in areas with sandy soil, use low lift blades on the cutting deck and higher cutting heights to minimize wear on the blower components.

- 4.2.2 Idler Bushings: **Service Interval: 25 Hours.**
Lubricate with 1-2 pumps of SAE No. 2 multi-purpose grease.

- 4.2.3 Door cloth mesh: **Service Interval: Daily.**

Inspect the cloth mesh for wear, tears, or damage.

 WARNING
POTENTIAL HAZARD ♦ Under normal use the cloth mesh will deteriorate and wear. Objects could exit through worn cloth mesh at high speeds.
WHAT CAN HAPPEN ♦ Thrown objects can cause serious injury or kill you or bystanders.
HOW TO AVOID THE HAZARD ♦ Check cloth mesh frequently for tears and holes. Replace worn cloth mesh.

4.2.4 Belts. **Service Interval: 50 Hours.**

Inspect the belt for damage or wear. Replace belt with one of the following.

60" deck – PN 103-0866

72" deck – PN 103-0867

4.2.5 Clean muffler and rear frame area: **Service Interval: Daily**

 WARNING
POTENTIAL HAZARD ♦ Operating engine parts, especially the muffler, become extremely hot.
WHAT CAN HAPPEN ♦ Severe burns can occur on contact. ♦ Debris, such as leaves, grass, brush, etc. can catch fire.
HOW TO AVOID THE HAZARD ♦ Allow engine parts, especially the muffler, to cool before touching. ♦ Remove accumulated debris from muffler and engine area. ♦ Install and maintain in working order a spark arrester before using equipment on forest-covered, grass-covered, brush-covered unimproved land.

5. SPECIFICATIONS

5.1 MODEL NUMBER:

LZUVD60

Use with drive kit: Lazer Z with 60" deck – 103-2973
 Lazer Z XP with 60" deck – 103-2976

Units below 190,000 require spindle kit 103-2998

Units between 190,000 and 260,000 require spindle kit 103-3140

Units between 260,000 and 352,000 require spindle kit 103-2999

LZUVD72

Use with drive kit: Lazer Z with 72" deck – 103-2974
 Lazer Z XP with 72" deck – 103-2977

Units below 260,000 require spindle kit 103-2999 and accessory tube kit 103-0583

Units between 260,000 and 352,000 require spindle kit 103-2999

5.2 DIMENSIONS

1 Overall unit length w/ Ultra Vac QDS

Lazer Z XP		
60" Deck	107.90"	(274.1 cm)
72" Deck	112.00"	(284.5 cm)

Lazer Z - Air Cooled		
60" Deck	106.65"	(270.9 cm)
72" Deck	110.75"	(281.3 cm)

Lazer Z - Liquid Cooled		
60" Deck	106.90"	(271.5 cm)
72" Deck	111.00"	(281.9 cm)

2 Overall unit width w/ Ultra Vac QDS

Lazer Z and Lazer Z XP		
60" Deck	74.44"	(189.1 cm)
72" Deck	86.49"	(219.7 cm)

5.3 BAGGING SYSTEM

5.3.1 Weight:

60" Deck – 290 lbs. (132 kg) includes weight kit

72" Deck – 237 lbs. (108 kg) includes weight kit

5.3.2 Collection Hopper: Steel and Polyethylene hopper. Commercial grade, cloth mesh door with reinforced bottom.

Capacity: 11.0 bushels

5.3.3 Dump Mechanism: Manual dump from seat

5.3.4 Blower tube: fixed, abrasion resistant molded polyethylene

5.3.5 Impeller: 5-bladed, 0.25" thick abrasion resistant steel, with vertical axis.

Impeller bearings: 1" (2.54 cm) sealed "non-greaseable bearings"

6. PARTS LISTS

6.1 DECALS



	WARNING	CAUTION
	<ul style="list-style-type: none"> • High Speed Discharge can cause Injury or Death • Do NOT run blower without discharge tube, hood and bags installed and latched 	<ul style="list-style-type: none"> • Read operator's manual • Hearing protection recommended

2

DANGER		DANGER
		<ul style="list-style-type: none"> • Rotating Blades can cause Injury or Death • Do NOT reach into Blower unless Rotation Indicator has Stopped. Disengage PTO, stop engine, remove key, WAIT FOR MOVING PARTS TO STOP • Do NOT operate mower without deflector chute or entire bag system in place.

103-3507

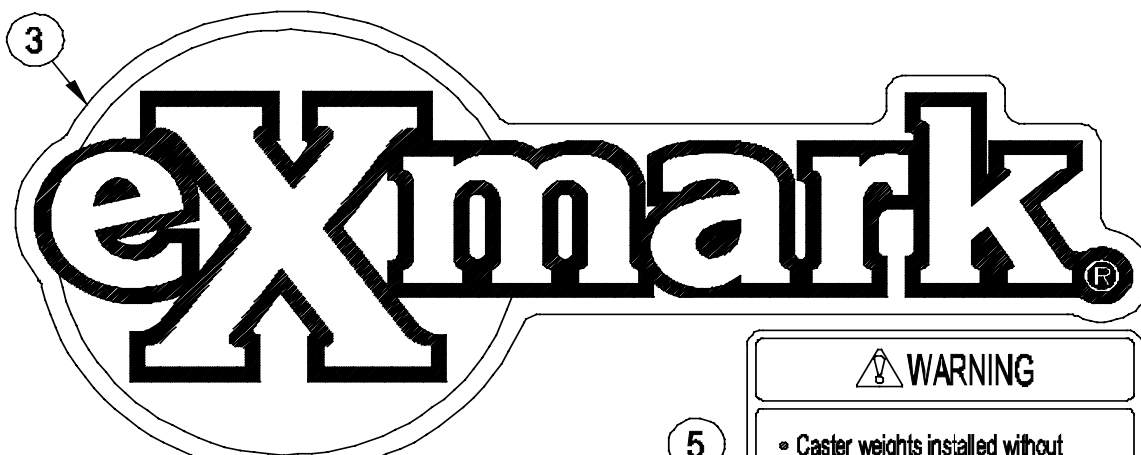

4

WARNING HOT SHEAVE
ALLOW TO COOL →

1-653558

6

DANGER
COVER IS MISSING. DO NOT OPERATE THIS UNIT WHEN COVER IS NOT IN PLACE. 98-5954

5

WARNING

- Caster weights installed without bagger may cause Loss of Traction and Steering Control.
- Bagger installed without caster weights will cause Reduction of Stability.
- Install caster weights ONLY when bagger is installed.

103-0878

Ref. No.	Part No.	Description	Qty. Req'd.
1	103-3302	Decal, Ultra Vac QDS.....	1
2	103-3507	Decal, Warning LZUV.....	1
3	103-0438	Decal, Exmark 60 & 72	1
4	1-653558	Decal, Hot Sheave.....	1
5	103-0878	Decal, Caster Weights.....	1
6	98-5954	Decal, Missing Cover	1

6.2 HITCH and HANDLE ASSEMBLY – LAZER Z 60 & 72 and LAZER Z XP 60 & 72

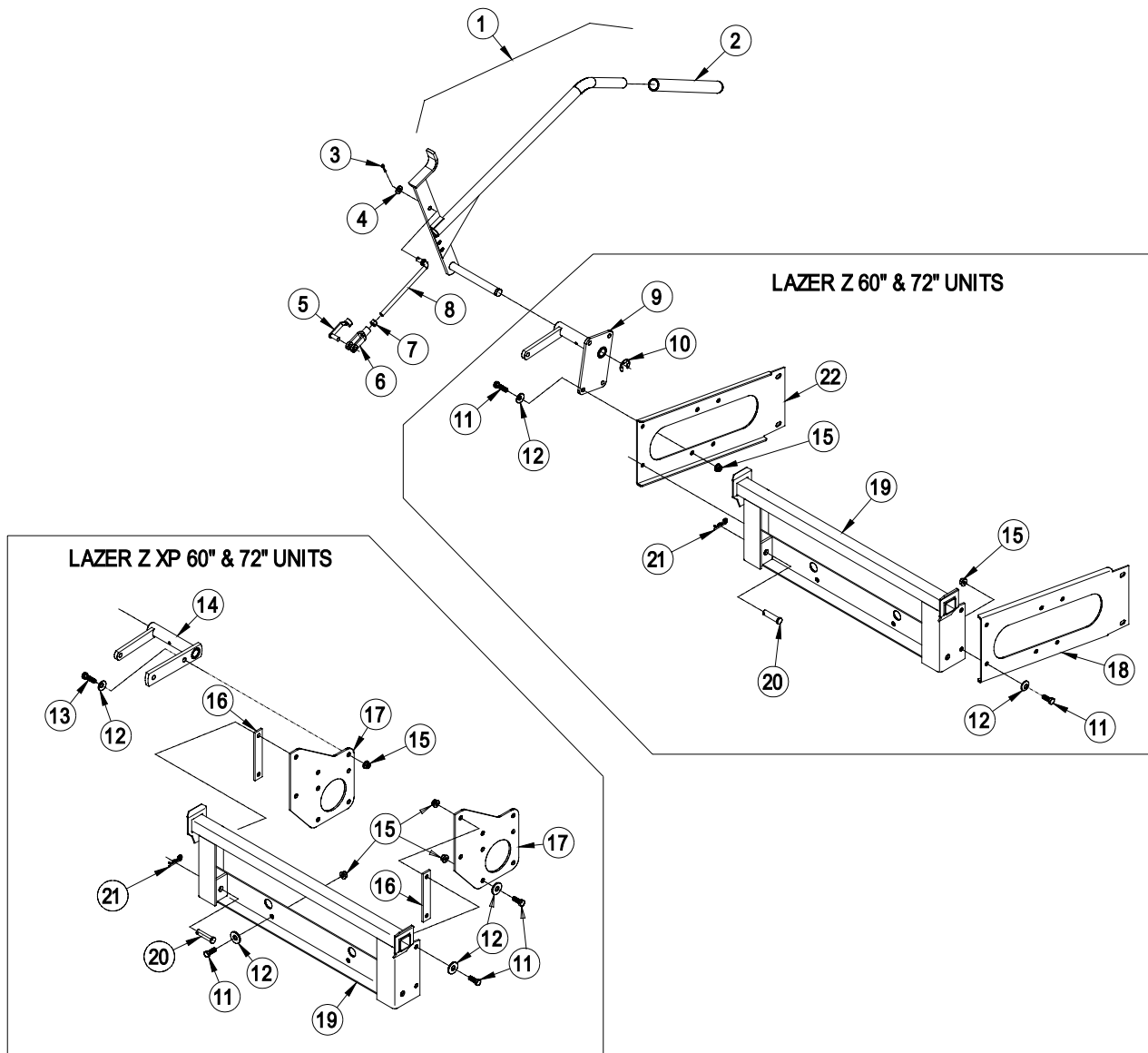

Ref. No.	Part No.	Description	Qty. Req'd.	Ref. No.	Part No.	Description	Qty. Req'd.
1	103-2738	Asm,handle w/grip	1	12	98-5975	Washer,spring disc (LZ)	12
2	103-3005	Grip,handle	1	12	98-5975	Washer,spring disc (XP)	16
3	3272-10	Pin,cotter .125 x .75	1	13	323-7	Screw,HH 3/8-16x1.25 (XP).....	2
4	3256-24	Washer,flat .406 x .813	1	14	103-2980-03	Wld,handle mount (XP)	1
5	103-2399	Pin,spring clevis 3/8	1	15	3290-357	Nut,whizlock 3/16-16 (LZ)	12
6	1-633131	Yoke,linkage brake	1	15	3290-357	Nut,whizlock 3/16-16 (XP).....	16
7	3219-3	Nut,HH 3/8-24	1	16	103-1155-03	Spacer (XP)	2
8	103-2413	Link,handle	1	17	103-1154-03	Plate,bagger mount (XP).....	2
9	103-2373-03	Wld,handle mount (LZ)	1	18	103-0399-03	Bracket,frame RH (LZ)	1
10	32151-48	E-ring	1	19	103-0429-03	Wld,bagger mount	1
11	323-6	Screw,HH 3/8-16x1 (LZ).....	12	20	283-69	Pin,clevis	2
	323-6	Screw,HH 3/8-16x1 (XP)	14	21	1-806005	Pin,hair	2
				22	103-2972-03	Bracket,frame LH (LZ).....	1

6.3 HOOD AND BAG ASSEMBLY – LAZER Z 60 & 72 and LAZER Z XP 60 & 72

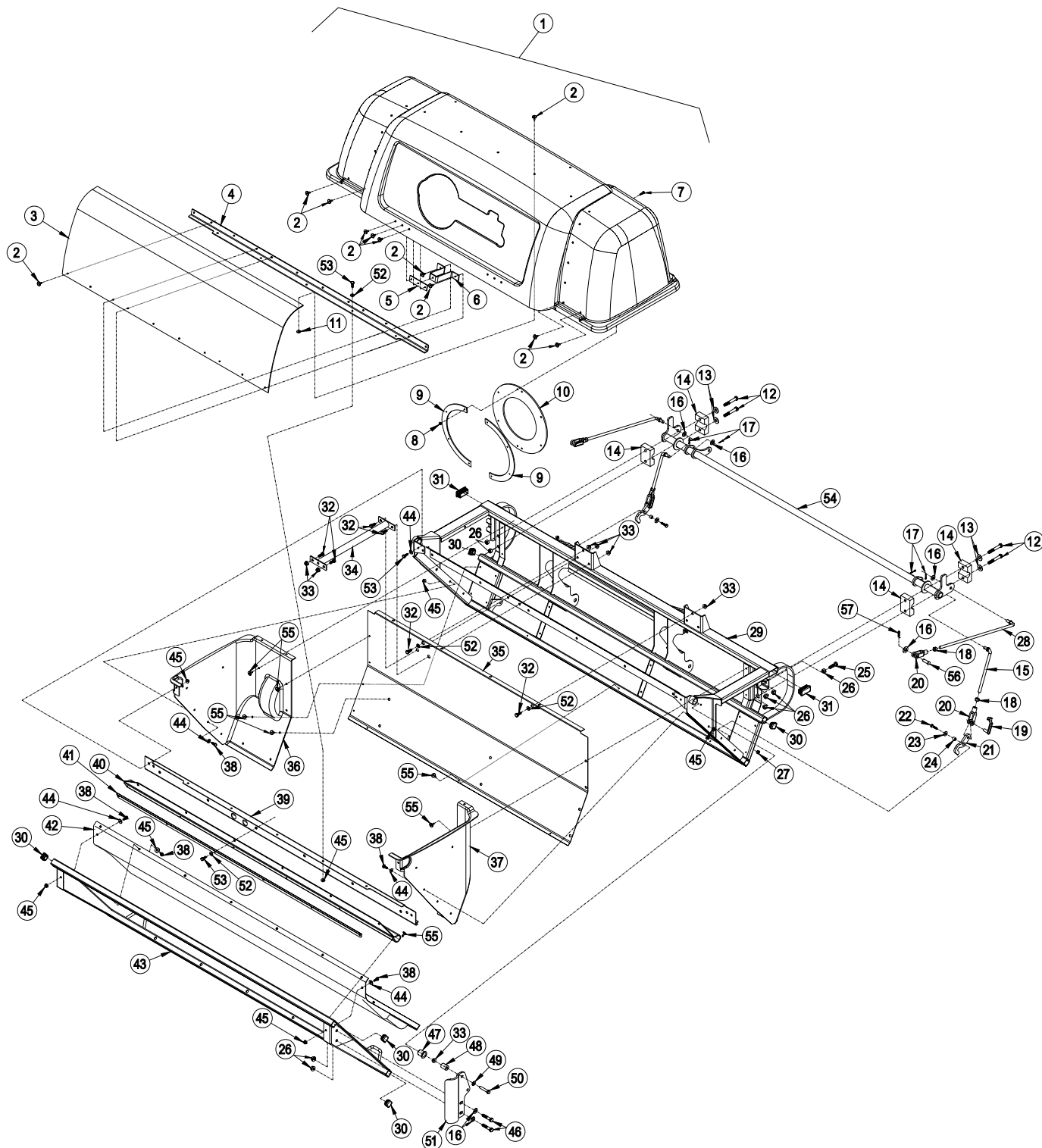

6.3 HOOD AND BAG ASSEMBLY – LAZER Z 60 & 72 and LAZER Z XP 60 & 72 (cont.)

Ref. No.	Part No.	Description	Qty. Req'd.	Ref. No.	Part No.	Description	Qty. Req'd.
1◆	103-2736	Asm,Hood Dump.....	1	30	103-3202	Cap,Tube 1 x 1.....	6
2	114439	Rivet,Pop 3/16 x 1/2.....	33	31	103-3201	Cap,Tube 1 x 2.....	2
3	103-0440	Screen,Bagger.....	1	32	322-3	Screw,HH 5/16-18 x .75.....	6
4	103-2662-03	Support,Screen.....	1	33	32128-20	Nut,Whizlock 5/16-18.....	8
5	103-0376	Plate,Latch reinforce.....	2	34	103-2414-03	Asm,Rear crossmember.....	1
6	103-0379	Bracket,Mount.....	2	35	103-2404-03	Sheet,wall.....	1
7	1-803075	Screw,#10-24x.75 CRTH.....	8	36	103-2419	Panel,Bagger LH.....	1
8	3296-2	Nut,Nyloc #10-24.....	8	37	103-2418	Panel,Bagger RH.....	1
9	103-0378	Clamp,Seal.....	2	38	321-3	Screw,HH 1/4-20 x .625.....	32
10	103-0439	Seal, Tube.....	1	39	103-2710	Asm,Rear crossmember.....	1
11	3256-61	Washer,Flat .216 x .750.....	15	40	103-2360	Seal,Door hinge.....	1
12	323-12	Screw,HH 3/8-16 x 2 1/2.....	4	41	103-3010-03	Strap,Hold down.....	1
13	3256-4	Washer,Flat 7/16 x 2.....	4	42	103-2383	Asm,Bag & bottom panel.....	1
14	103-2409	Bearing,Block half.....	4	43	103-2737	Asm,Door frame.....	1
15	103-2413	Linkage,Handle.....	2	44	3256-2	Washer,Flat .250 x .750.....	36
16	3256-24	Washer,Flat .406 x .813.....	10	45	32128-33	Nut,Whizlock 1/4-20.....	36
17	3272-10	Pin,Cotter 1/8 x 3/4.....	4	46	323-6	Screw,HH 3/8-16 x 1.0.....	4
18	3219-3	Nut,HH 3/8-24.....	4	47	103-2377	Bushing.....	2
19	103-2399	Pin,Spring clevis 3/8.....	2	48	103-2361	Pin,Hinge pivot.....	2
20	1-633131	Yoke,Brake linkage.....	4	49	3256-23	Washer,Flat .344 x .688.....	2
21	103-3191-03	Latch.....	2	50	322-9	Screw,HH 5/16-18 x 1.75.....	2
22	321-6	Screw,HH 1/4-20 x 1.....	2	51	103-3332-03	Arm,Hinge LH.....	1
23	3256-55	Washer,Flat 1/4.....	2		103-3331-03	Arm,Hinge RH (not shown)....	1
24	1-633545	Spacer,Gommet.....	2	52	3256-24	Washer,Flat .312 x .625.....	2
25	323-53	Bolt,Tap 3/8-16 x 1.75.....	2	53	321-4	Screw,HH 1/4-20 x 3/4.....	22
26	3290-357	Nut,HHF 3/8-16.....	12	54	103-2412-03	Wld,intermediate link.....	1
27	3296-42	Nut,Nyloc 1/4-20.....	2	55	114439	Rivet,Pop 3/16 x 1/2.....	23
28	103-2365	Link,Hinge.....	2	56	1-808285	Pin,Clevis.....	2
29	103-2434-03	Wld,Upright.....	1	57	1-806003	Pin,Hair.....	2

◆ Includes items 2 – 11 and large Exmark decal

6.4 BLOWER ASSEMBLY – LAZER Z 60 & 72 and LAZER Z XP 60 & 72

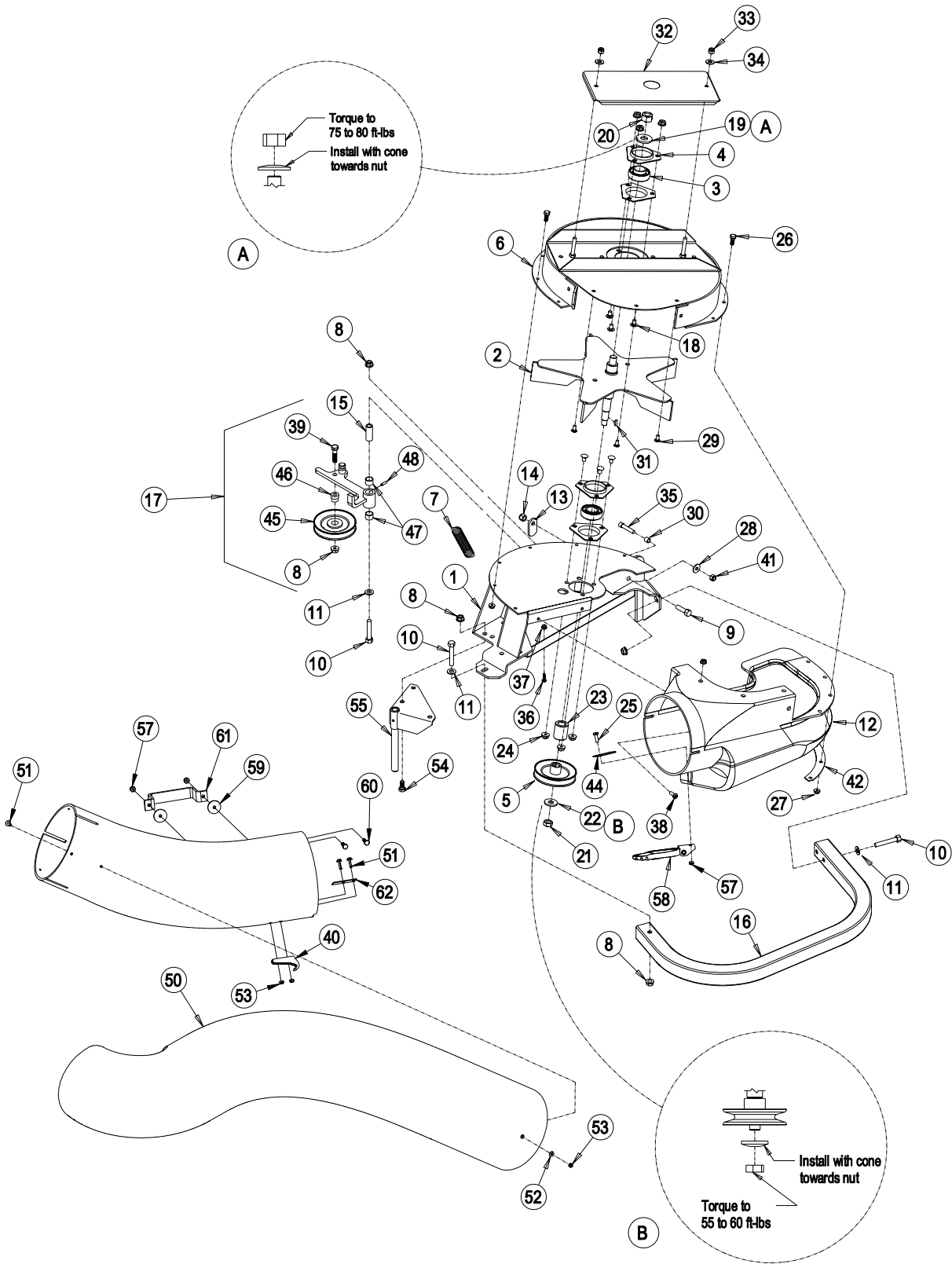

6.4 BLOWER ASSEMBLY – LAZER Z 60 & 72 and LAZER Z XP 60 & 72 (cont.)

Ref. No.	Part No.	Description	Qty. Req'd.	Ref. No.	Part No.	Description	Qty. Req'd.
1	103-0454-03	Blower mount wldmt 60" & 72".	1	32	103-3583	Cover, bearing (103-3584-03) with decal.	1
2	103-0455	Impeller wldmt.	1	33	3296-29	5/16-18 nyloc nut.	2
3	1-653346	Bearing, SPH. OD.	2	34	3256-3	5/16x7/8 OD flat washer.	2
4	1-513013	Housing, flange.	4	35	3274-18	5/16-18x1.25 Soc. Hd Screw.	1
5♦	103-0456	Sheave, blower.	1	36	1-803075	#10-24x.75 CRTH Screw.	3
6	103-3593	Upper housing weldment (103-0457-03) with decals.	1	37	1-809112	#10-24 whizlock nut.	3
7	1-653331	Spring, idler.	1	38	1-803076	1/4-20x.75 CRTH Screw.	2
8	3290-357	3/8-16 whizlock nut.	8	39	323-8	3/8 – 16 x 1.50 screw.	1
9	323-7	3/8-16 x 1.25 screw.	1	40	103-2897	Latch, catch.	1
10	323-11	3/8-16 x 2.25 screw.	4	41	3217-6	5/16-18 nut.	1
11	3256-4	Flat washer -.438x1.00x.083.	4	42	103-0461-03	Plate, Blower Backing.	1
12	103-0426	Chute, blower.	1	44	103-3093	Plate, backing.	1
13	1-353054	Latch, grass catcher.	1	45	103-0483	Idler.	1
14	3296-39	3/8-16 nyloc nut.	1	46	1-653367	Hub, spacer.	1
15	1-603044	Bushing, idler pivot.	1	47	1-653600	Bearing.	2
16	103-0458-01	Bumper.	1	48	302-19	Zerk, 1/8 – 28 straight.	1
17	103-0448	Idler Assy with bushings (103-0462-03) zerk, & decal.	1	49	103-2420	Tube, lower.	1
18	3230-18	5/16-18 x .62 carriage bolt.	6	50	103-0424	Tube, upper 60".	1
19	1-513208	Spring - disk.	1		103-0425	Tube, upper 72".	1
20	3219-6	5/8-18 nut.	1	51	32105-13	Screw, HWH #10-24 x .75.	8
21	3220-5	1/2-20 Jam nut.	1	52	3256-61	Washer, flat .216 x .75 x .05.	6
22	1-513435	Spring - disk.	1	53	3296-2	#10-24 Nyloc Nut.	8
23	103-0460	Spacer.	1	54	323-4	3/8-16 x .75 Hex Hd Screw.	3
24	32128-20	5-16-18 whizlock nut.	6	55	103-0445-03	Mount Pin weldment.	1
25	321-4	Screw, HH 1/4-20 x .75.	1	56	103-0450	Blower Assy, 60 & 72 (includes items 1-48 & decals).	1
26	321-3	1/4-20x.62 Hex Screw.	10	57	3296-42	Nut, nyloc 1/4-20.	3
27	32128-33	1/4-20 whizlock nut.	17	58	103-2898	Latch, rubber.	1
28	1-303334	5/16 Spring disk washer.	1	59	3256-55	Washer, flat .26 x 1.25.	2
29	3229-11	1/4-20x.62 Carr bolt		60	321-6	Screw, HH 1/4-20 x 1.00.	2
	RHSN.....5						
30	103-0126	Bushing, Locator.	1	61	1-353005-03	Handle.	1
31	3257-32	5/8x3/16 #61 Woodruff key.	1	62	103-3079	Plate, backing.	1

Exmark red touch up spray paint - P/N 1-850337

- ♦ Apply Mobil HTS grease (or a food-grade antisieze) on bore of sheave.

Kit 103-0583 is available to add or repair the welded on accessory mounting tube on all 44"-72" decks.

6.5 COMPLETING KIT ASSEMBLY – LAZER Z 60, & 72; Lazer Z XP 60 & 72

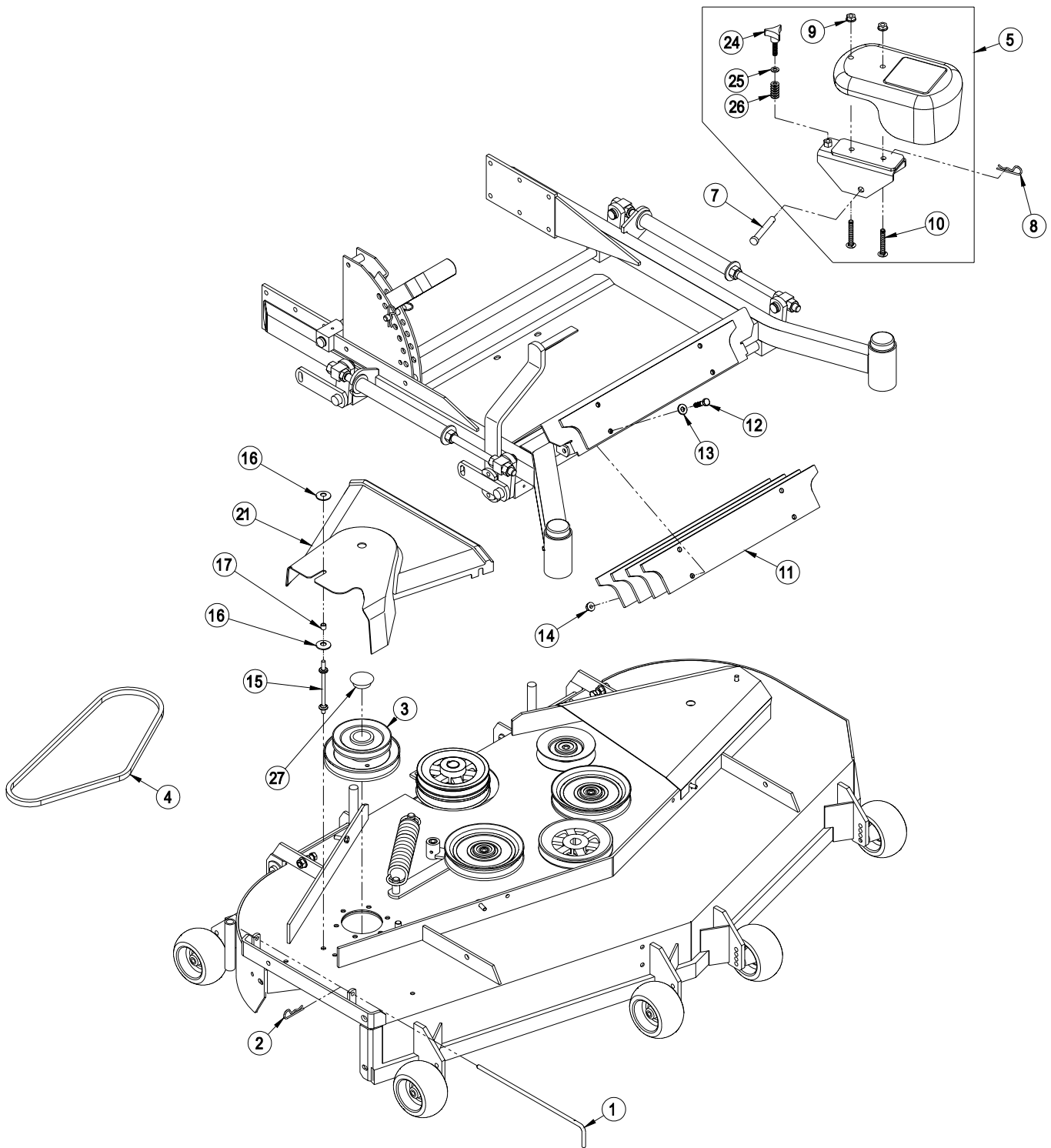

6.5 COMPLETING KIT ASSEMBLY - LAZER Z 60, & 72; LAZER Z XP 60 & 72 (cont.)

Ref. No.	Part No.	Description	LAZER		LAZER XP	
			60"	72"	60"	72"
			103-2973	103-2974	103-2976	103-2977
1	103-0453	Pin, Chute Pivot	1	1	1	1
2	1-806003	Pin, Hair	1	1	1	1
3	103-2792	Jackshaft, LZUV 60	1		1	
	103-2796	Jackshaft, LZUV 72		1		1
4	103-0866	Belt, Blower Drive 60	1		1	
	103-0867	Belt, Blower Drive 72		1		1
5	103-0899**	Weight, 70lb w/ 1.5" bracket	1			
	103-0900**	Weight, 70lb w/ 2.0" bracket	1			
	103-0902**	Weight, 43lb w/ 2.0" bracket		2	2	2
6	103-2180-01	Wld, Weight Bracket 2.0	1	2	2	2
	103-2181-01	Wld, Weight Bracket 1.5	1			
7	283-69	Pin, Clevis	2	2	2	2
8	1-806005	Hairpin, Cotter	2	2	2	2
9	3290-357	Nut, Whizlock 3/8-16	4	4	4	4
10	103-2500	Screw, Sq Head 3/8-16x2.5		4		4
	103-2189	Screw, Sq Head 3/8-16x4.0	4		4	
11	103-1425-01	Plate, Weight	5	5	5	5
12	322-7	Screw, HH 5/16 -18x1.5	4	4	4	4
13	3256-23	Washer, flat 5/16	4	4	4	4
14	32128-20	Nut, Whizlock 5/16-18	4	4	4	4
15	103-1028	Stud, Belt Shield	1	1	1	1
16	1-603610	Washer, Spring Disc 7/16	2		2	
17	1-633545	Spacer, Grommet	1		1	
18						
19						
20						
21	103-0735	Belt Cover 60"	1		1	
	103-0736	Belt Cover 72"		1		1
22*	1-543610	Washer, 1/4	2			
23*	323-49	Bolt, Tap 3/8-16x3.25	2			
24	103-2187	Knob	2	2	2	2
25	3256-24	Washer	2	2	2	2
26	103-2188	Spring	2	2	2	2
27	103-1279	Plug	1	1	1	1

* Items Not Shown. Used for mounting the bagger mount weldment to the rear of the units with Serial Numbers less than 190,000

** Includes items 6, 9, 10, weight and decal.

7. WARRANTY

Limited Warranty Exmark Commercial Turf Equipment

Exmark Mfg. Co. Inc. and its affiliate, Exmark Warranty Company, pursuant to an agreement between them, jointly warrant on the terms and conditions herein, that we will repair, replace or adjust any part manufactured by Exmark and found by us (in the exercise of our reasonable discretion) to be defective in factory material or workmanship.

This warranty is limited to one year from the date of original retail purchase (90 days for rental use) for any Exmark mower that is used for commercial or any other income producing purpose. The blade spindle assemblies will be warranted for three years, one year parts and labor with an additional two years parts only, from date of original retail purchase against defects in materials or workmanship. The frame and hydrostatic traction drive system, excluding hoses, will be warranted for two full years from date of original retail purchase against defects in materials or workmanship. We will extend the Peerless 5-speed transmission manufacturer's warranty from 90 days to one year. Belts and tires are warranted for 90 days against defects in materials or workmanship.

The engine warranty is covered by its respective engine manufacturer. Please refer to the engine manufacturer's warranty statement that is included in the literature packet. We are not authorized to handle warranty adjustments on engines. Engine warranties should be referred to the nearest authorized service outlet of the engine manufacturer.

This warranty extends only to the original retail purchaser of the equipment. This warranty may not be assigned or transferred without the prior express written consent of Exmark and Exmark Warranty Company. The warranty period commences upon the date of the original retail purchase.

The Exmark turf equipment, including any defective part, must be returned to an authorized Exmark service dealer within the warranty period. The warranty shall extend to the expense of repair or replacement (as determined by us) of the defective part, including labor. The warranty shall not extend to the expense of delivering the mower to the dealer for warranty work nor the expense of returning it back to the owner after repair or replacement. Our responsibility in respect to claims is limited to making the required repairs or replacements, and no claim of breach of warranty shall be cause for cancellation or rescission of the contract of sale of any Exmark mower. Proof of purchase may be required by the dealer to substantiate any warranty claim. All warranty work must be performed by an authorized Exmark service dealer.

This warranty extends only to turf equipment operated under normal conditions and properly serviced and maintained. The warranty expressly does not cover: (i) any damage or deterioration due to normal use, wear and tear, or exposure; (ii) normal maintenance services, such as oil change, cleaning, lubrication; adjustment; (iii) replacement of service items, such as oil, lubricants, spark plugs, or other items subject to normal service replacement; (iv) damage or defects arising out of or relating to misuse, neglect, alteration, negligence or accident; (v) repair or replacement arising from operation of or use of the turf equipment which is not in accordance with operating instructions as specified in the operator's manual or other operational instructions provided by Exmark; (vi) repair or replacement arising as a result of any operation from turf equipment that has been altered or modified so as to, in the determination of Exmark or Exmark Warranty Company, adversely affect the operation, performance or durability of the equipment or that has altered, modified or affected the turf equipment so as to change the intended use of the product; (vii) repair or replacement necessitated by use of parts, accessories or supplies, including gasoline, oil or lubricants, incompatible with the turf equipment or other than as recommended in the operator's manual or other operational instructions provided by Exmark; (viii) repairs or replacements resulting from parts or accessories which have adversely affected the operation, performance or durability of the turf equipment; or (ix) damage or defects due to or arising out of repair of turf equipment by person or persons other than an authorized Exmark service dealer or the installation of parts other than genuine Exmark or Exmark recommended parts. As a condition to this warranty, customer shall have read the operator's manual and shall have completed and returned to Exmark Warranty Company, within the prescribed time, the Exmark warranty registration.

The sole liability of Exmark and Exmark Warranty Company with respect to this warranty shall be repair and replacement as set forth herein. Neither Exmark nor Exmark Warranty Company shall have any liability for any other cost, loss or damage, including but not limited to, any incidental or consequential loss or damage. In particular, we shall have no liability or responsibility for: (i) expenses relating to gasoline, oil or lubricants; (ii) loss, cost or expense relating to transportation or delivery of turf equipment from the location of owner or location where used by owner to or from any authorized Exmark service dealer; (iii) travel time, overtime, after hours time or other extraordinary repair charges or charge relating to repairs or replacements outside of normal business hours at the place of business of the authorized Exmark service dealer; (iv) rental of like or similar replacement equipment during the period of any warranty, repair or replacement work; (v) any telephone or telegram charges or travel charges; (vi) loss or damage to person or property other than that covered by the terms of this warranty; (vii) any claims for lost revenue, lost profit or additional cost as a result of a claim of breach of warranty; or (viii) attorney's fees.

There are no representations or warranties which have been authorized and provided to the buyer of the turf equipment, other than as set forth in this warranty. Any and all statements or representations made by any seller of this equipment, including those set forth in any sales literature or made orally by any sales representative, are superseded by the terms of this warranty. Any affirmation of fact or promise made by Exmark, Exmark Warranty Company or any of their representatives to the buyer which relates to the goods that are the subject of this warranty shall not be regarded as part of the basis of the bargain and shall not be deemed to create any express warranty that such goods shall conform to the affirmation or promise.

THERE ARE NO UNDERSTANDINGS, AGREEMENTS, REPRESENTATIONS, OR WARRANTIES, EXPRESS OR IMPLIED (INCLUDING BUT NOT LIMITED TO ANY REGARDING THE MERCHANTABILITY OR FITNESS FOR A PARTICULAR PURPOSE), NOT SPECIFIED HEREIN, RESPECTING THE EQUIPMENT WHICH IS THE SUBJECT OF THIS WARRANTY.

This warranty applies to all Exmark turf equipment sold in the United States and Canada and intended to be used for commercial purposes.

**SEE EXMARK'S COMPLETE
LINE OF PRODUCTS FOR TURF CARE**

LAZER Z[®]

LAZER Z[®] HP

LAZER Z[®] XP

TURF RANGER[®]

TURF TRACER[®]

TURF TRACER[®] HP

VIKING HYDRO

METRO[®]

METRO[®] HP

SELF STEERING SULKY

ULTRA VAC[™]

ULTRA VAC QDS[™]

GRASS CATCHER

MICRO-MULCH[™] ACCESSORY

©2000 - 2002 EXMARK MFG. CO. INC. PART NO. 103-2716 Rev C
INDUSTRIAL PARK BOX 808 (402) 223-6300
BEATRICE, NE 68310 FAX (402) 223-5489

ALL RIGHTS RESERVED

PRINTED IN U.S.A.

