

\$1.50

RAPTOR II RACING ENGINES

Illustrated Parts List Motorsports Model Series



133230

TYPE NUMBER
8014.



WARNING:



- **MODEL 133230-8014-01 IS A RACING ENGINE**
- **SPECIAL SKILLS AND KNOWLEDGE ARE REQUIRED TO PREPARE THE ENGINES FOR COMPETITIVE USE. IF YOU ARE NOT FAMILIAR WITH THE PROPER TECHNIQUES AND PROCEDURES, HAVE QUALIFIED INDIVIDUALS DO THE WORK FOR YOU**
- **THE ENGINES DO NOT HAVE GOVERNORS. ANY THROTTLE MECHANISM MUST HAVE A RETURN-TO-IDLE SPRING SO THE ENGINE WILL RETURN TO IDLE SPEED WHEN THE THROTTLE PEDAL IS RELEASED**

**FAILURE TO FOLLOW THESE WARNINGS COULD
RESULT IN SERIOUS PERSONAL INJURY OR DEATH**

TO FIND THE CORRECT NUMBER OF THE PART YOU NEED: FOLLOW THE INSTRUCTIONS ON THE REVERSE SIDE

- Refer to Engine Model, Type and Code Number that is stamped on the blower housing of engine. Engine type numbers such as 0123 01 are listed only as 0123 in most instances. The two digits (01 or 02, etc.) to the right of the space may be required for more accurate parts identification in some instances. Select the Illustrated Parts List covering the correct Model Series and Type Number.
- Refer to the Illustrations and compare the original part with Illustration. The number next to the illustration is the Reference Number. Assemblies include all parts shown in frames. All parts shown in assembly frames having individual reference numbers can be purchased separately.
- After the Reference Number has been identified, refer to the Numerical text, where Reference and Primary Part Number are listed. **THE PRIMARY PART IS USED ON ALL TYPE NUMBERS EXCEPT THOSE TYPE NUMBERS UNDER "NOTE."**
- If a "Note" appears below the Primary Part Number, it means that this part differs from the Primary Part for certain types. If your Type number is listed under "Note," order the part referred to at the "Note."
- If your Engine Type Number does not appear after any part number listed under "Note," use the Primary Part Number.
- For Engine Type Numbers not covered by this book, check other Parts Lists having the same engine model or contact your source of supply.

PRINTED IN U.S.A.



BRIGGS & STRATTON



COPYRIGHT by BRIGGS & STRATTON CORPORATION
All rights reserved. No part of this material may be reproduced or transmitted, in any form or by any means, electronic or mechanical, including photocopying, recording or by any information storage and retrieval system, without permission in writing from Briggs & Stratton Corporation.

In the Interest of Safety



This safety alert symbol indicates that this message involves personal safety. The words “danger”, “warning” and “caution” indicate degree of hazard. Death, personal injury and/or property damage may occur unless instructions are followed carefully.



You are not ready to operate this engine if you have not read and understood the following safety items. Read the entire owner's manual and the operating instructions of the equipment this engine powers.

The Briggs & Stratton engine is made of the finest material in a state-of-the-art manufacturing facility. Please understand that Briggs & Stratton sells engines to original equipment manufacturers. It also sells to others in the distribution chain who may sell to the ultimate consumer, an equipment manufacturer, another distributor or a dealer. As a result, Briggs & Stratton does not necessarily know the application on which the engine will be placed. For that reason, carefully read and understand the operating instructions of the equipment before you repair or operate it.

You should also understand that there are equipment applications for which Briggs & Stratton does not approve the use of its engines. Briggs & Stratton engines are not to be used on vehicles with less than 4 wheels. They include motor bikes, aircraft products and All Terrain Vehicles. Moreover, Briggs & Stratton does not approve of its engines being used in competitive events. FOR THAT REASON, BRIGGS & STRATTON ENGINES ARE NOT AUTHORIZED FOR ANY OF THESE APPLICATIONS. Failure to follow this warning could result in death, serious injury (including paralysis) or property damage.



DO NOT run engine in an enclosed area. (Exhaust gases contain carbon monoxide, an odorless and deadly poison.)

DO NOT remove fuel tank cap nor fill fuel tank while engine is hot or running. DO NOT refuel indoors or in an unventilated area. (Allow engine to cool 2 minutes before refueling.)

DO NOT place hands or feet near moving or rotating parts.

DO NOT store, spill, or use gasoline near an open flame, nor near an appliance like a stove, furnace, or water heater that uses a pilot light or can create a spark.

DO NOT refuel indoors or in an unventilated area.

DO NOT operate or tip engine/equipment at such a severe angle that causes gasoline spillage.

DO NOT operate engine if gasoline is spilled or when smell of gasoline is present or other explosive conditions exist. (Move equipment away from spill and avoid any ignition until gasoline has evaporated.)

DO NOT transport engine with fuel in tank or fuel shut-off valve open.

DO NOT choke carburetor to stop engine, especially in an enclosed vehicle. (Whenever possible, gradually reduce engine speed before stopping.)

DO NOT tamper with governor springs, links or other parts to increase engine speed. (Run engine at speed set for equipment manufacturer.)

DO NOT check for spark with spark plug removed. (Use an approved tester.)

DO NOT run engine without blower housing or other safety shields removed when doing repairs.

DO NOT crank engine with spark plug removed. (If engine is flooded, place throttle in FAST and crank until engine starts.)

DO NOT strike flywheel with a hammer or hard object as this may cause flywheel to shatter in operation. (To remove flywheel, use Briggs & Stratton approved tools and procedures only.)

DO NOT operate engine without a muffler. (Inspect periodically and replace if worn or leaking. If engine is equipped with muffler deflector, inspect periodically and replace if necessary. Replacement parts must be same as on original equipment.)

DO NOT operate engine with an accumulation of grass, leaves or other combustible material in muffler area.

DO NOT use this engine on any forest covered, brush covered, or grass covered unimproved land unless a spark arrester is installed on muffler. The spark arrester must be maintained in working order by the owner and/or operator. In the State of California the above is required by law (Section 4442 of the California Public Resources Code). Other states may have similar laws. Federal laws apply on federal lands.

DO NOT touch hot muffler, cylinder, or fins which can cause burns.

DO NOT start engine with air cleaner or air cleaner cover removed (or cover over carburetor air intake, if Sno/Gard engine).

DO NOT attempt to start engine with cutting blade loose or removed. (Blade must be tight, otherwise a kickback may occur.)



- ✓ Prior to work, read and understand the section(s) of this manual that pertain to the job. Follow all safety warnings.
- ✓ PULL starter cord slowly until resistance is felt. Then pull cord rapidly to avoid kickback and prevent hand or arm injury.
- ✓ WEAR suitable eye protection (safety glasses, goggles or face shield when performing repair procedures.
- ✓ PREVENT ACCIDENTAL STARTING by removing spark plug wire from spark plug when servicing engine or equipment. Disconnect negative wire from battery terminal if equipped with electric starting system.
- ✓ REMOVE blower housing periodically and clean engine. Keep cylinder fins and governor parts free of dirt, grass and other debris which can affect engine speed.
- ✓ USE fresh gasoline. Stale fuel can gum carburetor and cause leakage.
- ✓ CHECK fuel lines and fittings frequently for cracks or leaks. Replace if necessary.
- ✓ USE ONLY Genuine Briggs & Stratton Parts or their equivalent. The use of replacement parts which are not of equivalent quality may damage the engine.

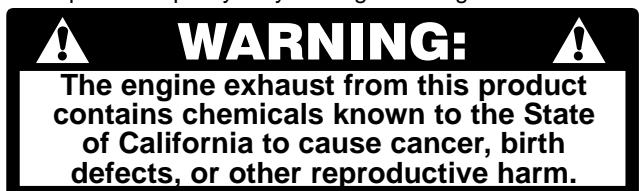

133230

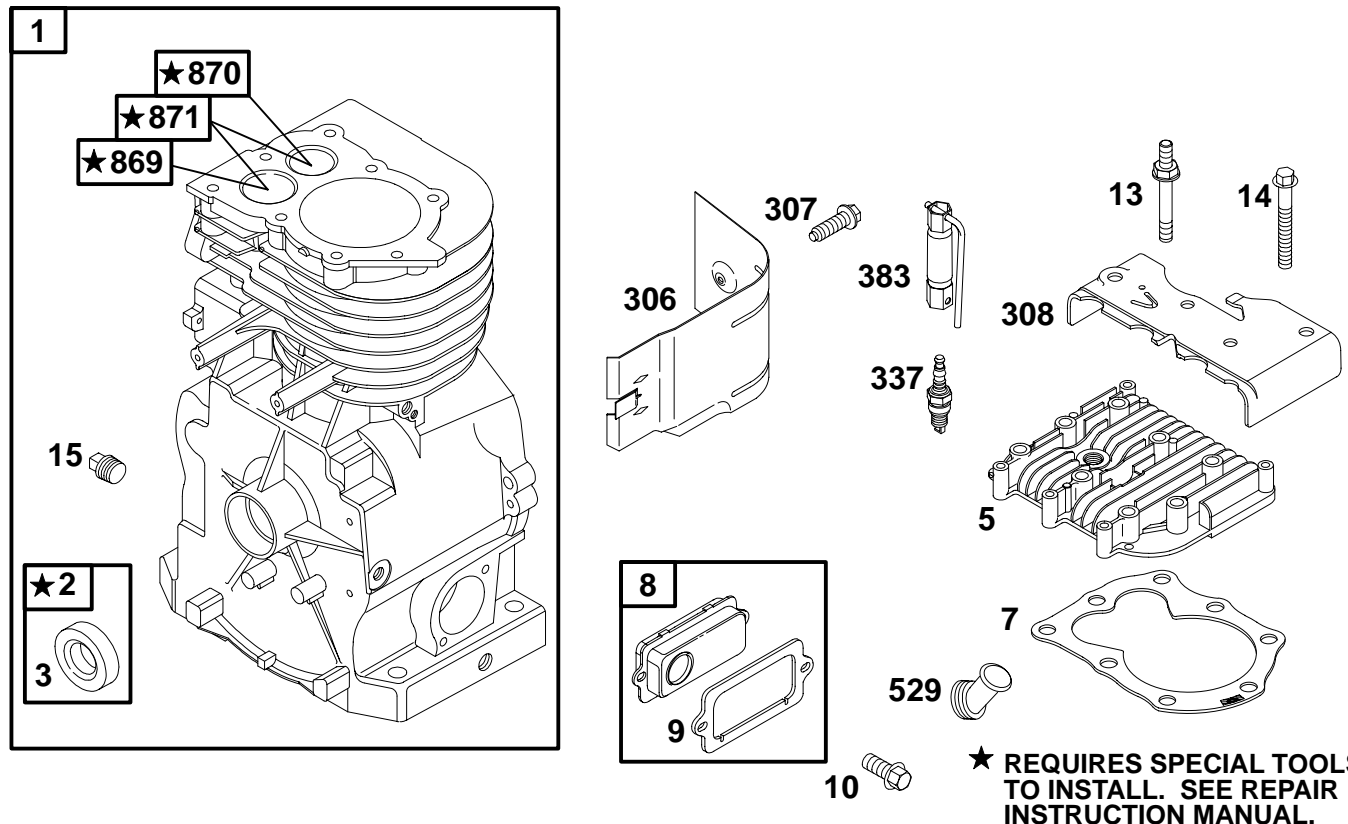

| REF. NO. | PART NO. | DESCRIPTION | REF. NO. | PART NO. | DESCRIPTION | REF. NO. | PART NO. | DESCRIPTION |
|----------|----------|-------------------------------------|----------|----------|-------------------------|----------|----------|------------------------------|
| 1 | 555206 | Cylinder Assembly | 306 | 555057 | Shield-Cylinder | 871 | 555214 | Bushing-Guide Exhaust Valve) |
| 2 | 555140 | Bushing | 307 | 555046 | Screw (Cylinder Shield) | | | (Sintered Bronze) |
| 3 | ★555071 | Seal-Oil | 308 | 555056 | Cover-Cylinder Head | OR | | |
| 5 | 555257 | Head-Cylinder | 337 | 555132 | Plug-Spark | 555158 | | Bushing-Guide Exhaust Valve) |
| 7 | ★555187 | Gasket-Cylinder Head | 383 | 89838 | Wrench-Spark Plug | | | (Sintered Iron) |
| 8 | 555073 | Breather Assembly | 529 | 555074 | Grommet | | | Note |
| 9 | ★555036 | Gasket-Breather | 869 | 555136 | Seat-Intake Valve | 555139 | | Bushing-Guide Intake Valve) |
| 10 | 555043 | Screw (Breather) | 870 | 555137 | Seat-Exhaust Valve | | | |
| 13 | 555082 | Stud-Cylinder Head | | | | | | |
| 14 | 555045 | Screw Cylinder Head (2 15/32" Long) | | | | | | |
| 15 | 555079 | Plug-Oil Drain | | | | | | |

★ Included in Gasket Set-Part No. 555210.

● Included in Carburetor Kit-Part No. 555130.

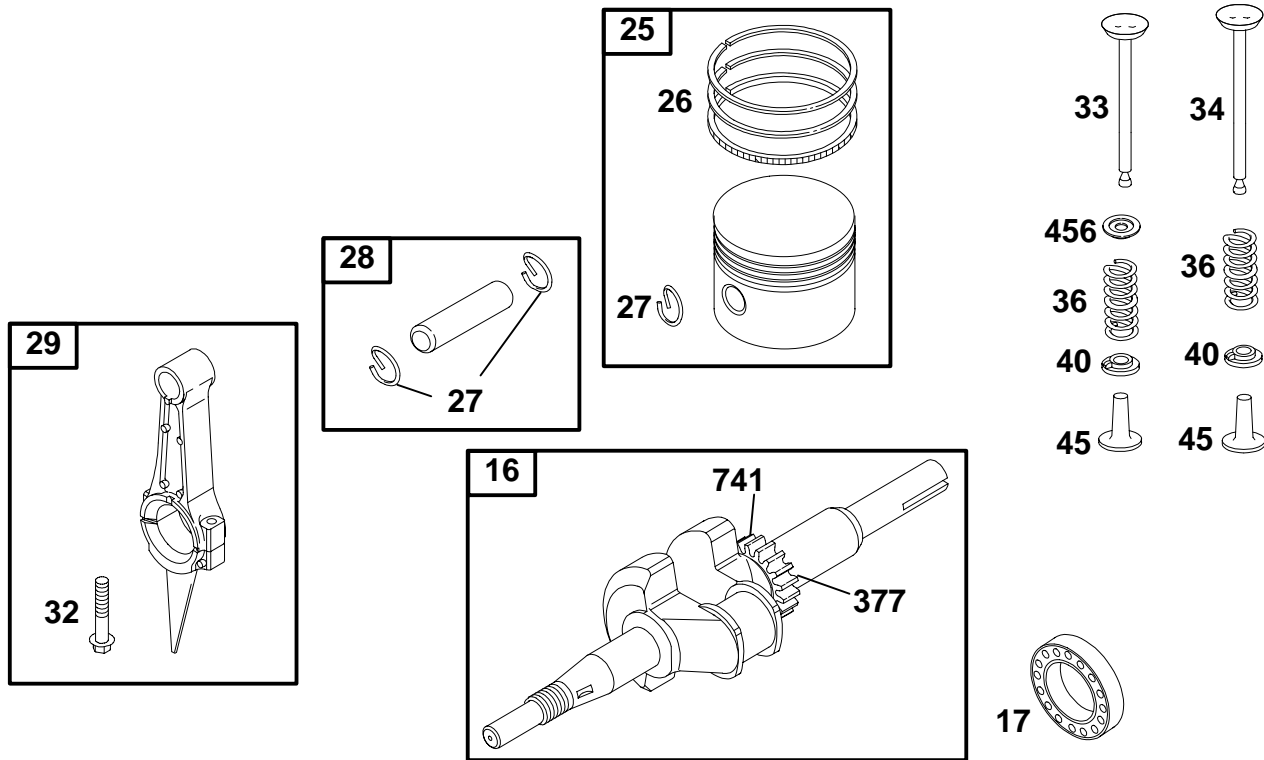

| REF. NO. | PART NO. | DESCRIPTION | REF. NO. | PART NO. | DESCRIPTION | REF. NO. | PART NO. | DESCRIPTION |
|----------|----------|----------------------------------|----------|----------|----------------------------------|----------|----------|------------------------|
| 16 | 555204 | Crankshaft | 27 | 555035 | Lock-Piston Pin | 40 | 555039 | Retainer-Spring |
| 17 | 555050 | Bearing-Ball | 28 | 555058 | Pin-Piston (Standard) | 45 | 555061 | Tappet-Valve |
| 25 | 555092 | Piston Assembly | | | Note | 377 | 555049 | Key-Woodruff |
| | | Note | | | 555059 | 555147 | 555147 | Retainer-Spring |
| | | 555093 Piston Assy. (.010" O.S.) | | | (.005" O.S.) | 741 | 555235 | Gear-Timing (Tempered) |
| | | 555094 Piston Assy. (.020" O.S.) | 29 | 555207 | Rod-Connecting (Standard) | | | |
| | | 555095 Piston Assy. (.030" O.S.) | | | Note | | | |
| 26 | 555088 | Ring Set (Standard) | | | 555208 | | | |
| | | Note | 32 | 555070 | Rod-Connecting (.020" Undersize) | | | |
| | | 555089 Ring Set (.010" O.S.) | | | Screw-Connecting Rod | | | |
| | | 555090 Ring Set (.020" O.S.) | 33 | 555077 | Valve-Exhaust | | | |
| | | 555091 Ring Set (.030" O.S.) | 34 | 555062 | Valve-Intake | | | |
| | | | 36 | 555076 | Spring-Valve | | | |

★ Included in Gasket Set-Part No. 555210.

● Included in Carburetor Kit-Part No. 555130.

133230

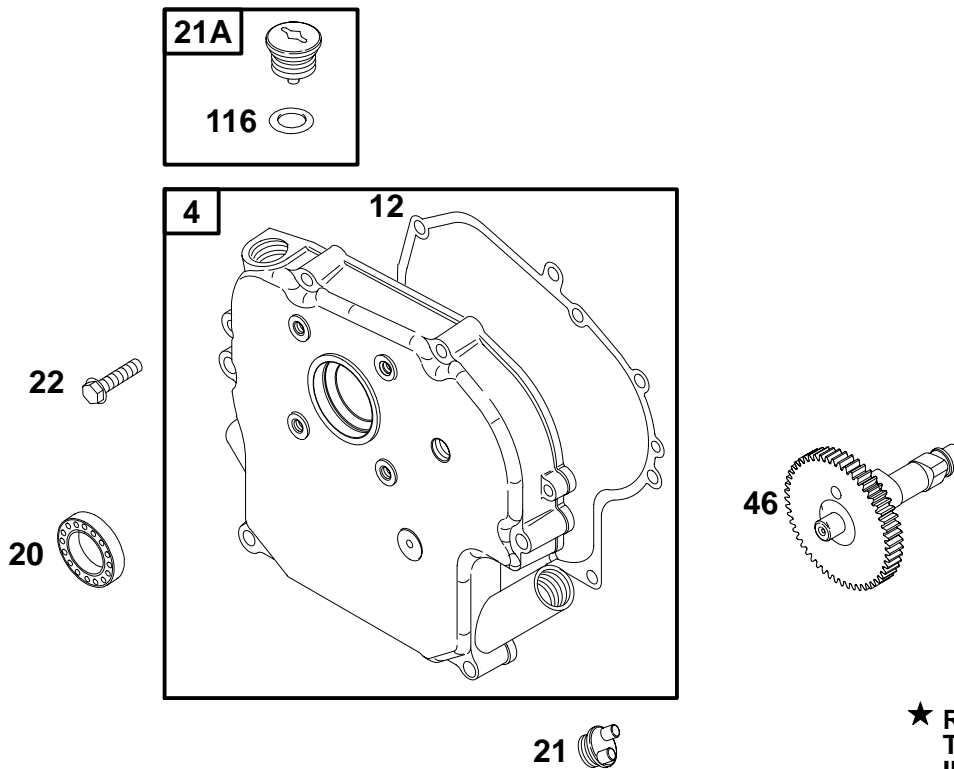

★ **REQUIRES SPECIAL TOOLS TO INSTALL. SEE REPAIR INSTRUCTION MANUAL.**

| REF. NO. | PART NO. | DESCRIPTION | REF. NO. | PART NO. | DESCRIPTION | REF. NO. | PART NO. | DESCRIPTION |
|----------|----------|--------------------------------------|----------|----------|---------------|----------|----------|------------------------------------|
| 4 | 555209 | Cover-Crankcase | 20 | ★555087 | Seal-Oil | 46 | 555052 | Gear-Cam (Machined Lobes) |
| 12 | ★555191 | Gasket-Crankcase (.015" Thick, Std.) | 21 | 555037 | Plug-Oil Fill | | | Note |
| | ★555064 | Gasket-Crkse. (.005" Thick) | 21A | 555138 | Plug-Oil Fill | | | 555000 Gear-Cam (Unmachined Lobes) |
| | ★555065 | Gasket-Crkse. (.009" Thick) | 22 | 555047 | Screw-Hex. | 116 | ★555135 | Ring-Oil Retainer |

★ Included in Gasket Set-Part No. 555210.

● Included in Carburetor Kit-Part No. 555130.

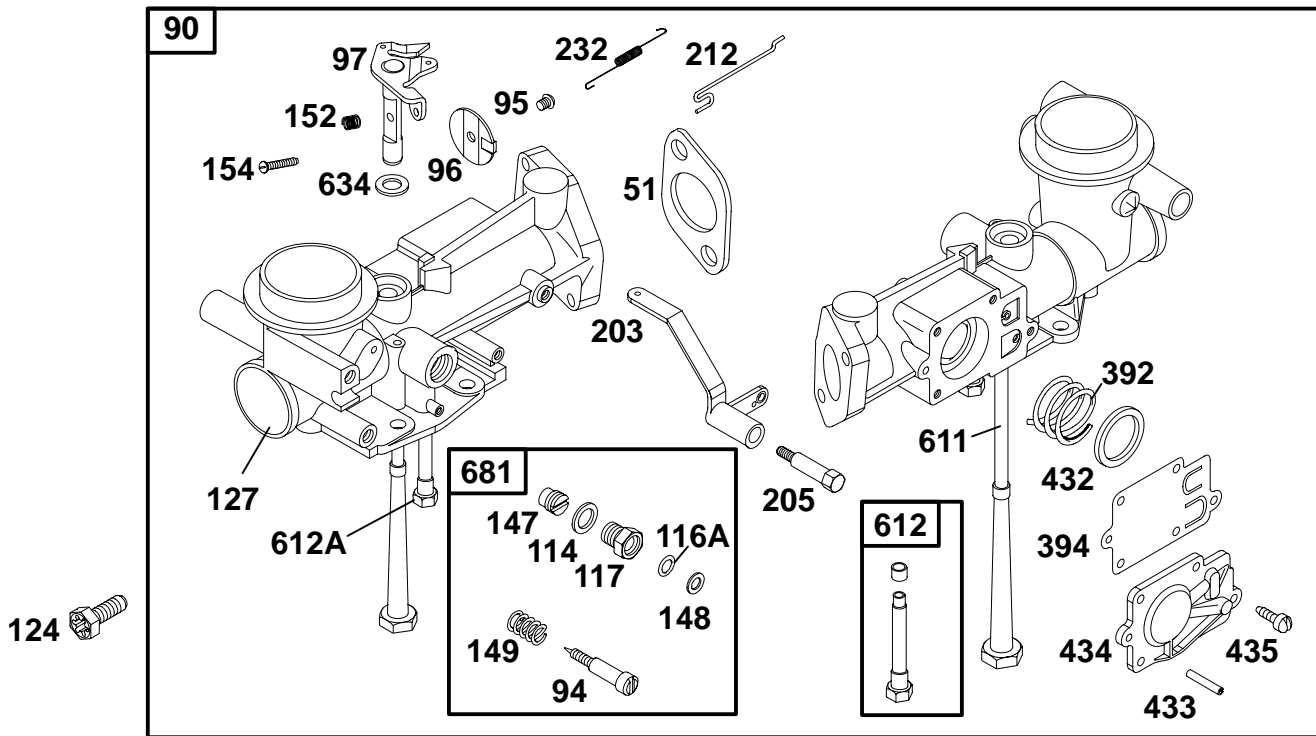

| REF. NO. | PART NO. | DESCRIPTION | REF. NO. | PART NO. | DESCRIPTION | REF. NO. | PART NO. | DESCRIPTION |
|----------|----------|---------------------------|----------|----------|---------------------|----------|----------|----------------------|
| 51 | ★555078 | Gasket-Intake Elbow | 127 | 555105 | Plug-Welch | 394 | ★555119 | Diaphragm-Carburetor |
| 90 | 555129 | Carburetor | 147 | ★555114 | Seat-Needle Valve | 432 | 555113 | Cap-Spring |
| 94 | ★555124 | Valve-Idle Adjustment | 148 | ★555125 | Washer-Needle Valve | 433 | 555108 | Pin-Roll |
| 95 | 555232 | Screw-Hex. | 149 | ★555123 | Spring-Needle Valve | 434 | 555112 | Cover-Diaphragm |
| 96 | 555109 | Valve-Throttle | 152 | 555101 | Spring-Adjustment | 435 | 555107 | Screw-Hex. |
| 97 | 555100 | Shaft-Throttle | 203 | 555104 | Crank-Bell | 611 | 555103 | Tube-Pick-up |
| 114 | ★555106 | Gasket-Valve | 205 | 555110 | Screw-Shoulder | 612 | 555128 | Tube-Pick-up |
| 116A | ★555122 | Packing-Valve | 212 | 555116 | Link-Throttle | 612A | 555120 | Tube-Pick-up |
| 117 | ★555126 | Nut-Needle Valve | 232 | 555117 | Spring-Link | 634 | 555118 | Washer-Shaft |
| 124 | 555238 | Screw-Carburetor Mounting | 392 | 555115 | Spring-Diaphragm | 681 | ★555127 | Valve-Needle Kit |

★ Included in Gasket Set-Part No. 555210.

● Included in Carburetor Kit-Part No. 555130.

133230

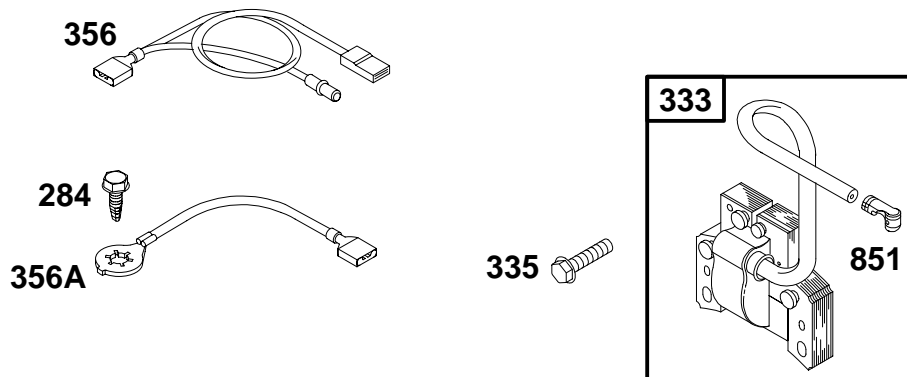

| REF. NO. | PART NO. | DESCRIPTION | REF. NO. | PART NO. | DESCRIPTION | REF. NO. | PART NO. | DESCRIPTION |
|----------|----------|------------------|----------|----------|-----------------------------------|----------|----------|---|
| 284 | 555080 | Screw-Hex. | 356 | 555086 | Wire-Stop (Armature to Switch) | 356A | 555099 | Wire-Stop (Stop Switch to Ground) |
| 333 | 555075 | Armature-Magneto | | | | 851 | 555072 | Terminal-Cable |
| 335 | 555040 | Screw-Hex. | | | | | | |

★ Included in Gasket Set-Part No. 555210.

● Included in Carburetor Kit-Part No. 555130.

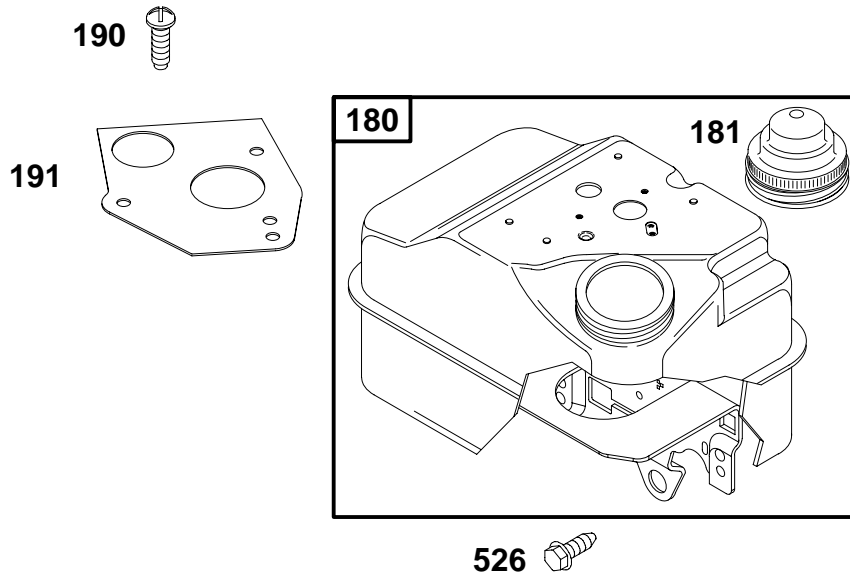

| REF. NO. | PART NO. | DESCRIPTION | REF. NO. | PART NO. | DESCRIPTION | REF. NO. | PART NO. | DESCRIPTION |
|------------|---------------|---------------|------------|----------------|------------------|------------|---------------|-------------|
| 180 | 555192 | Tank-Fuel | 190 | 555048 | Screw-Hex. | 526 | 555044 | Screw-Hex. |
| 181 | 555085 | Cap-Fuel Tank | 191 | ★555084 | Gasket-Tank Mtg. | | | |

★ Included in Gasket Set-Part No. 555210.

● Included in Carburetor Kit-Part No. 555130.

133230

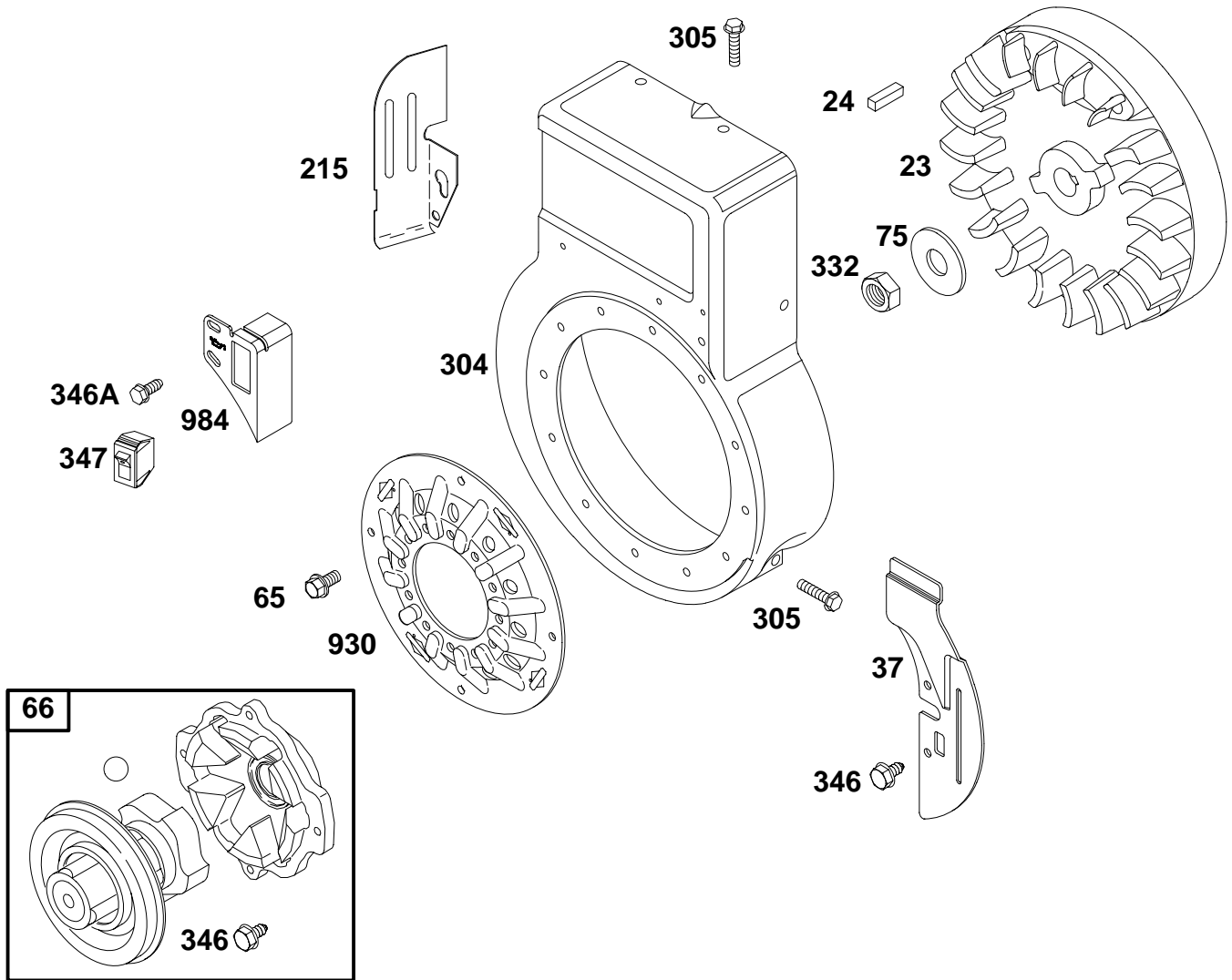

★ **REQUIRES SPECIAL TOOLS TO INSTALL. SEE REPAIR INSTRUCTION MANUAL.**

| REF. NO. | PART NO. | DESCRIPTION | REF. NO. | PART NO. | DESCRIPTION | REF. NO. | PART NO. | DESCRIPTION |
|----------|----------|-----------------|----------|----------|----------------|----------|----------|-------------------------|
| 23 | 555067 | Flywheel | 215 | 555055 | Guide-Air | 346A | 555081 | Screw-Hex. |
| 24 | 555054 | Key-Flywheel | 304 | 555256 | Housing-Blower | 347 | 555098 | Switch-Stop |
| 37 | 555053 | Guard-Flywheel | 305 | 555051 | Screw-Hex. | 930 | 555255 | Guard-Finger |
| 65 | 555211 | Screw-Torx® | 332 | 555038 | Nut-Hex. | 984 | 555097 | Bracket-Indicator Light |
| 66 | 555171 | Clutch-Starter | 346 | 555046 | Screw-Hex. | | | |
| 75 | 555083 | Washer-Flywheel | | | | | | |

★ Included in Gasket Set-Part No. 555210.

● Included in Carburetor Kit-Part No. 555130.

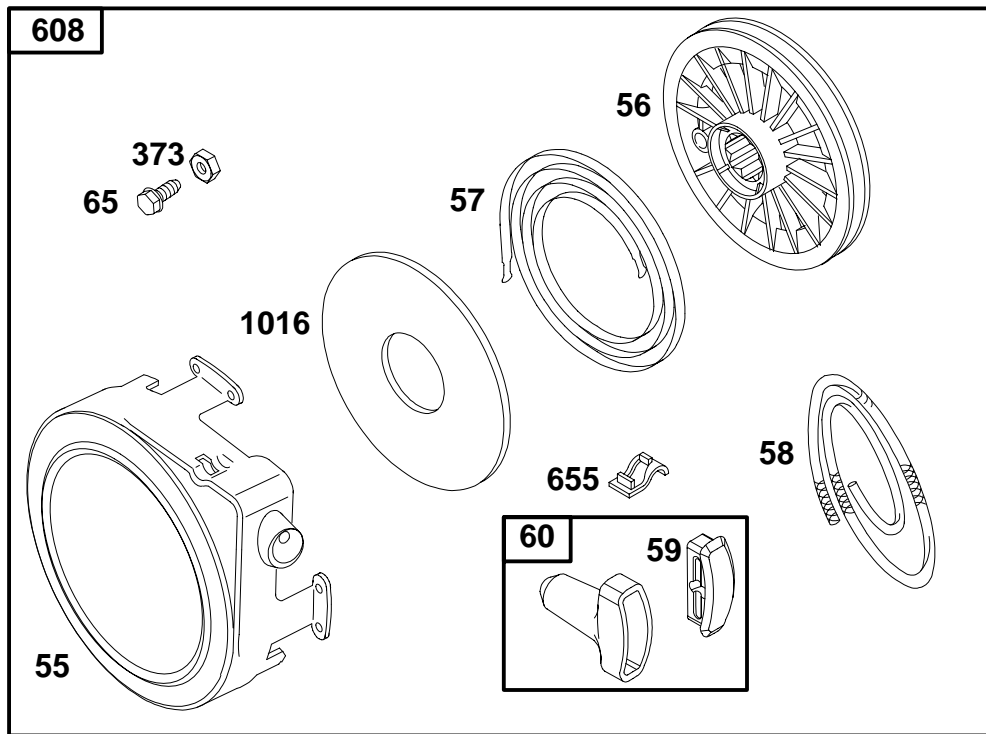

| REF. NO. | PART NO. | DESCRIPTION | REF. NO. | PART NO. | DESCRIPTION | REF. NO. | PART NO. | DESCRIPTION |
|----------|----------|------------------------|----------|----------|-------------------------|----------|----------|----------------|
| 55 | 555222 | Housing–Rewind Starter | 58 | 555221 | Rope–Starter (63" Long) | 373 | 555230 | Nut–Hex. |
| 56 | 555224 | Pulley–Starter | 59 | 555227 | Insert–Grip | 608 | 555165 | Starter–Rewind |
| 57 | 555226 | Spring–Rewind Starter | 60 | 555228 | Grip–Starter Rope | 655 | 555223 | Anchor–Spring |
| | | | 65 | 555229 | Screw–Hex. | 1016 | 555225 | Spacer–Rewind |

★ Included in Gasket Set–Part No. 555210.

● Included in Carburetor Kit–Part No. 555130.

133230

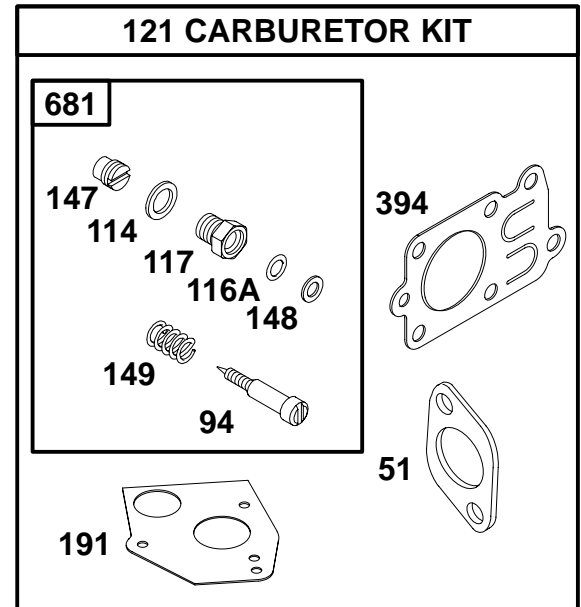
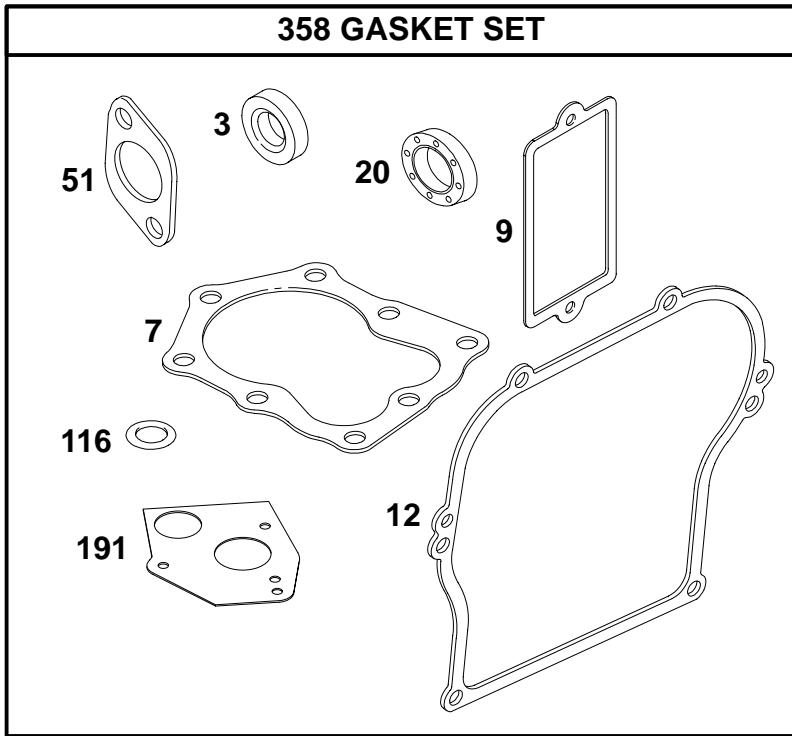

| REF. NO. | PART NO. | DESCRIPTION | REF. NO. | PART NO. | DESCRIPTION | REF. NO. | PART NO. | DESCRIPTION |
|----------|----------|---|----------|----------|-----------------------|----------|----------|----------------------|
| 3 | ★555071 | Seal-Oil | 20 | ★555087 | Seal-Oil | 149 | ●555123 | Spring-Needle Valve |
| 7 | ★555187 | Gasket-Cylinder Head | 51 | ★555078 | Gasket-Intake Elbow | 191 | ★●555084 | Gasket-Tank Mtg. |
| 9 | ★555036 | Gasket-Breather | 94 | ●555124 | Valve-Idle Adjustment | 358 | 555210 | Gasket Set |
| 12 | ★555191 | Gasket-Crankcase (.015" Thick, Std.) | 114 | ●555106 | Gasket-Valve | 394 | ●555119 | Diaphragm-Carburetor |
| | ★555064 | Gasket-Crankcase (.005" Thick) | 116 | ★555135 | Ring-Oil Retainer | 681 | ●555127 | Valve-Needle Kit |
| | ★555065 | Gasket-Crankcase (.009" Thick) | 116A | ●555122 | Packing Valve | | | |
| | | | 117 | ●555126 | Nut-Needle Valve | | | |
| | | | 121 | 555130 | Carburetor Kit | | | |
| | | | 147 | ●555114 | Seat-Needle Valve | | | |
| | | | 148 | ●555125 | Washer-Needle Valve | | | |

★ Included in Gasket Set-Part No. 555210.

● Included in Carburetor Kit-Part No. 555130.