

Illustrated Parts List

Model Series

90200 to 90299

TYPE NUMBERS
0100, 0101, 0104,
0107, 0108, 0216.

TO FIND
THE CORRECT NUMBER OF THE PART YOU NEED:
FOLLOW THE INSTRUCTIONS BELOW

- A. Refer to Engine Model, Type and Code Number that is stamped on the blower housing of engine. Engine type numbers such as 0123 01 are listed only as 0123 in most instances. The two digits (01 or 02, etc.) to the right of the space may be required for more accurate parts identification in some instances. Select the Illustrated Parts List covering the correct Model Series and Type Number.
- B. Refer to the Illustrations and compare the original part with Illustration. The number next to the illustration is the Reference Number. Assemblies include all parts shown in frames. All parts shown in assembly frames having individual reference numbers can be purchased separately.
- C. After the Reference Number has been identified, refer to the Numerical text, where Reference and Primary Part Number are listed. **THE PRIMARY PART IS USED ON ALL TYPE NUMBERS EXCEPT THOSE TYPE NUMBERS UNDER "NOTE."**
- D. If a "Note" appears below the Primary Part Number, it means that this part differs from the Primary Part for certain types. If your Type number is listed under "Note," order the part referred to at the "Note."
- E. If your Engine Type Number does not appear after any part number listed under "Note," use the Primary Part Number.
- F. For Engine Type Numbers not covered by this book, check other Parts Lists having the same engine model or contact your source of supply.

PRINTED IN U.S.A.



COPYRIGHT by BRIGGS & STRATTON CORPORATION
All rights reserved. No part of this material may be reproduced or transmitted, in any form or by any means, electronic or mechanical, including photocopying, recording or by any information storage and retrieval system, without permission in writing from Briggs & Stratton Corporation.

90200 to 90299

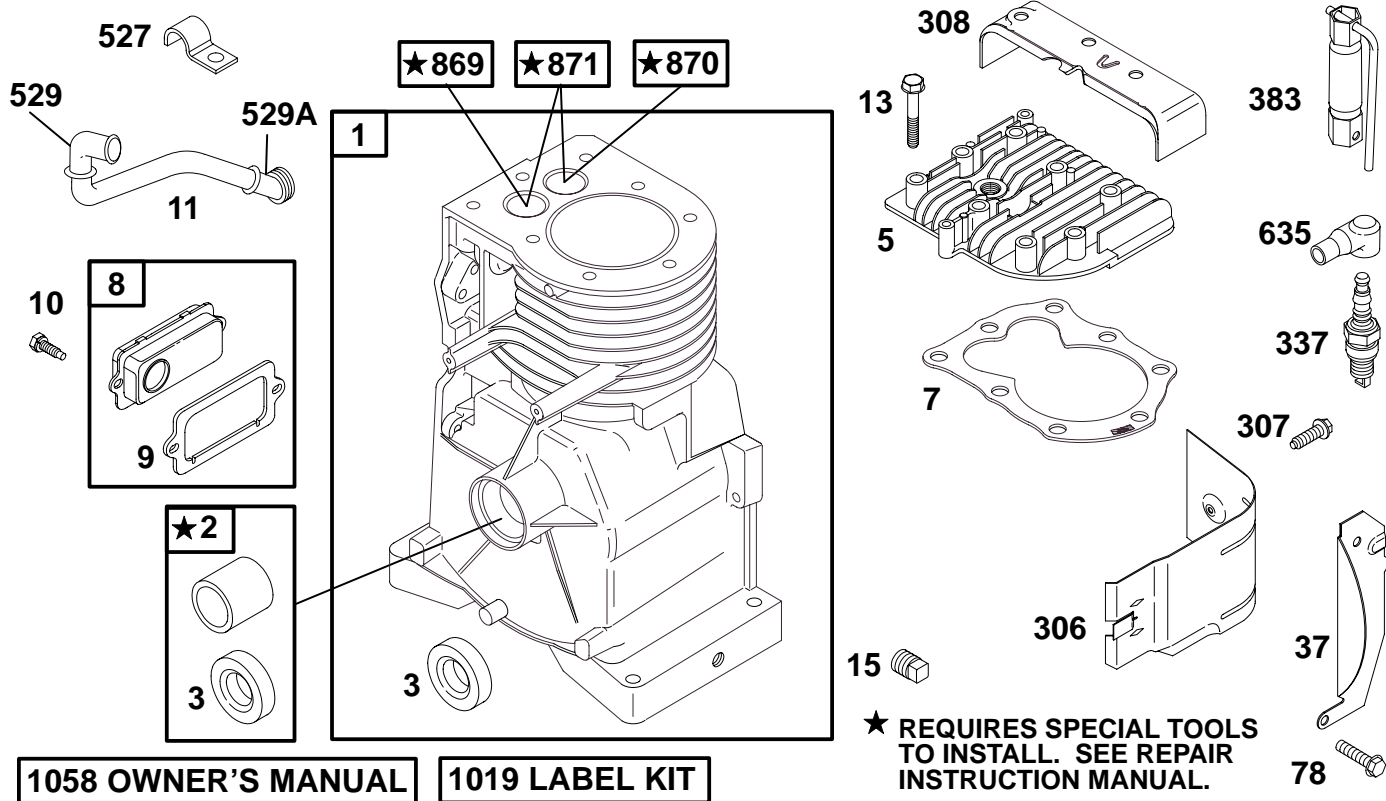

1058 OWNER'S MANUAL

1019 LABEL KIT

★ REQUIRES SPECIAL TOOLS TO INSTALL. SEE REPAIR INSTRUCTION MANUAL.

REF. NO.	PART NO.	DESCRIPTION	REF. NO.	PART NO.	DESCRIPTION	REF. NO.	PART NO.	DESCRIPTION
1	494549	Cylinder Assembly	10	94621	Screw (Breather)	529	★67838	Grommet
2	399269	Bushing/Seal Kit	11	231527	Tube-Breather	529A	★66578	Grommet
3	★299819	Seal-Oil	13	94960	Screw (Cylinder Head)	635	66538	Boot-Spark Plug
5	214277	Head-Cylinder	15	94916	Plug-Oil Drain	869	211172	Seat-Valve (Intake)
		Note	37	224557	Guard-Flywheel	870	211291	Seat-Valve (Exhaust)
		213942 Head-Cylinder (Used Before Code Date 96080100).	78	94811	Screw (Flywheel Guard)	871	262001	Bushing-Guide (Exhaust Valve)
7	272694	Gasket-Cylinder Head	306	224555	Shield-Cylinder			Note
		Note	307	93758	Screw (Cylinder Shield)			231348 Bushing-Guide (Exhaust Valve)
		Ø★272536 Gasket-Cylinder Head (Used Before Code Date 96080100).	308	224556	Cover-Cylinder			(Used Before Code Date 92072000).
8	495774	Breather Assembly	337	492167	Plug-Spark			63709 Bushing-Guide (Intake Valve)
9	Ø★27549	Gasket-Breather			Note	1019	491069	Label Kit
					802592 Plug-Spark (Resistor Type)	1058	272484	Owner's Manual
			383	89838	Wrench-Spark Plug			
			527	223786	Clamp-Tube			

★ Included in Gasket Set-See Ref. 358.

Ø Included in Valve Overhaul Gasket Set-Part 498524.

90200 to 90299

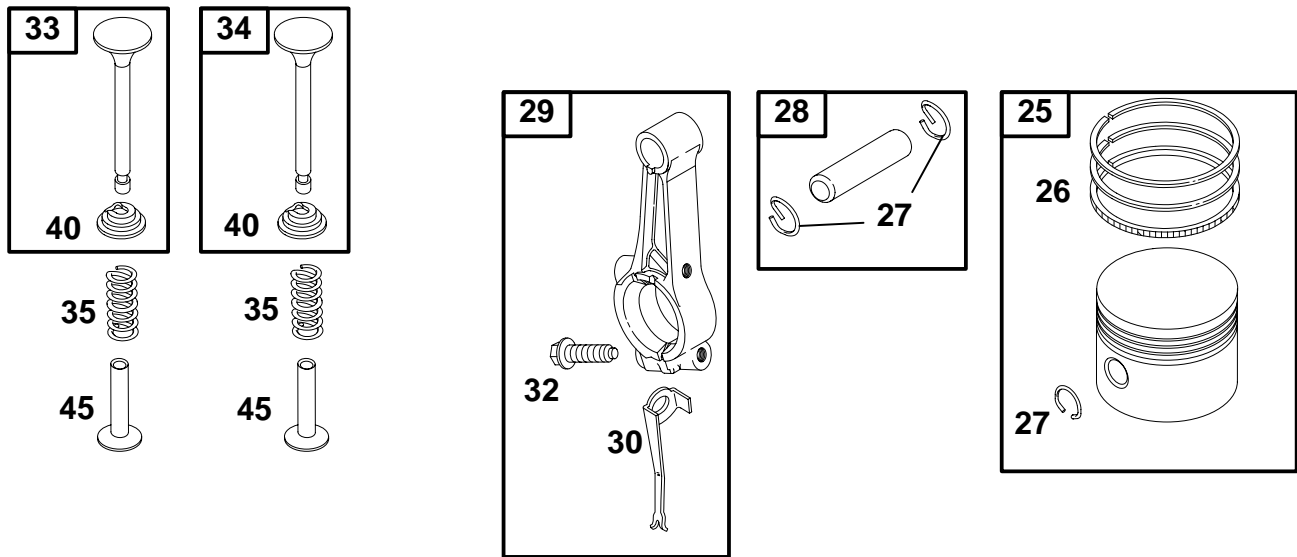

REF. NO.	PART NO.	DESCRIPTION	REF. NO.	PART NO.	DESCRIPTION	REF. NO.	PART NO.	DESCRIPTION		
25	498668	Piston Assembly (Standard) Note 298904 Piston Assy. (Standard) (Used Before Code Date 96012900)	26	498680	Ring Set (Standard) Note 298982 Ring Set (Standard) (Used Before Code Date 96012900).	28	298909	Pin-Piston (Standard) Note 298908 Pin-Piston (.005" O.S.)		
	498669	Piston Assy. (.010" O.S.)		498681	Ring Set (.010" O.S.)		29	294367	Rod-Connecting (Standard) Note 296079 Rod-Conn. (.020" Undersize)	
	298905	Piston Assy. (.010" O.S.) (Used Before Code Date 96012900).		298983	Ring Set (.010" O.S.) (Used Before Code Date 96012900).		30	220670	Dipper-Connecting Rod	
	498670	Piston Assy. (.020" O.S.)		498682	Ring Set (.020" O.S.)		32	94699	Screw (Connecting Rod)	
	298906	Piston Assy. (.020" O.S.) (Used Before Code Date 96012900).		298984	Ring Set (.020" O.S.) (Used Before Code Date 96012900).		33	296676	Valve-Exhaust	
	498671	Piston Assy. (.030" O.S.)		498683	Ring Set (.030" O.S.)		34	296677	Valve-Intake	
	298907	Piston Assy. (.030" O.S.) (Used Before Code Date 96012900).		298985	Ring Set (.030" O.S.) (Used Before Code Date 96012900).		35	260552	Spring-Valve	
				27	26026		Lock-Piston Pin	40	93312	Retainer-Valve
								45	230173	Tappet-Valve

★ Included in Gasket Set-See Ref. 358.

Ø Included in Valve Overhaul Gasket Set-Part 498524.

90200 to 90299

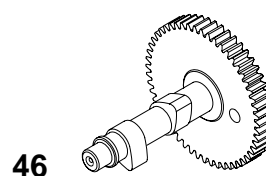
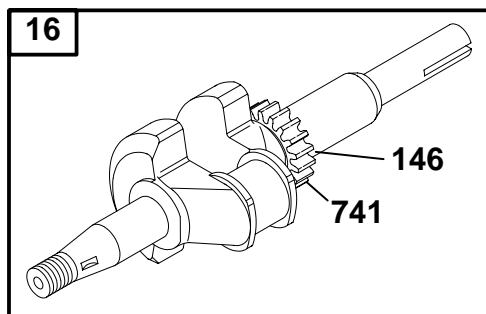

REF. NO.	PART NO.	DESCRIPTION	REF. NO.	PART NO.	DESCRIPTION	REF. NO.	PART NO.	DESCRIPTION
16	493632	Crankshaft	17	495484	Bearing-Ball	146	499047	Key-Timing
		Note	24	222698	Key-Flywheel	357	91539	Key-Drive Pulley
	492880	Crankshaft Used on Type No(s). 0101, 0104.	46	493747	Gear-Cam	741	261533	Gear-Timing
	493599	Crankshaft Used on Type No(s). 0108.						
	495211	Crankshaft (Used After Code Date 93071900). Used on Type No(s). 0107.						
	493633	Crankshaft (Used Before Code Date 93072000). Used on Type No(s). 0107.						

★ Included in Gasket Set-See Ref. 358.

⊘ Included in Valve Overhaul Gasket Set-Part 498524.

★ REQUIRES SPECIAL TOOLS TO INSTALL. SEE REPAIR INSTRUCTION MANUAL.

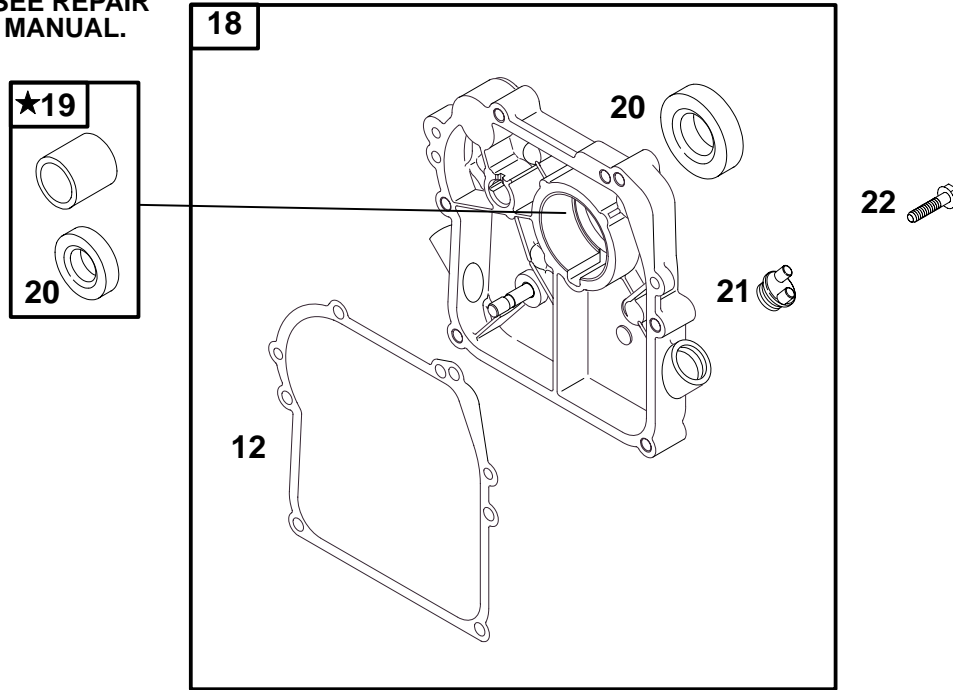

REF. NO.	PART NO.	DESCRIPTION	REF. NO.	PART NO.	DESCRIPTION	REF. NO.	PART NO.	DESCRIPTION
12	★270833	Gasket-Crankcase (.015" Thick, Std.) ———— Note ———— ★270895 Gasket-Crankcase (.005" Thick) ★270896 Gasket-Crankcase (.009" Thick)	18	496679	Cover-Crankcase ———— Note ———— 394820 Cover-Crankcase Used on Type No(s). 0101, 0104. 497502 Cover-Crankcase Used on Type No(s). 0107.	20	★299819	Seal-Oil ———— Note ———— 495355 Seal-Oil Used on Type No(s). 0100, 0107, 0216.
			19	220538	Bushing/Seal Kit ———— Note ———— 399269 Bushing/Seal Kit Used on Type No(s). 0101.	21	281658	Cap-Oil Fill
						22	94682	Screw (Crankcase Cover) ———— Note ———— 94885 Screw-Hex. Used in positions 1 and 6. Used on Type No(s). 0180. 94970 Screw-Hex. Used in positions 1 and 6 Used on Type No(s). 0216.

★ Included in Gasket Set—See Ref. 358.

Ø Included in Valve Overhaul Gasket Set—Part 498524.

90200 to 90299

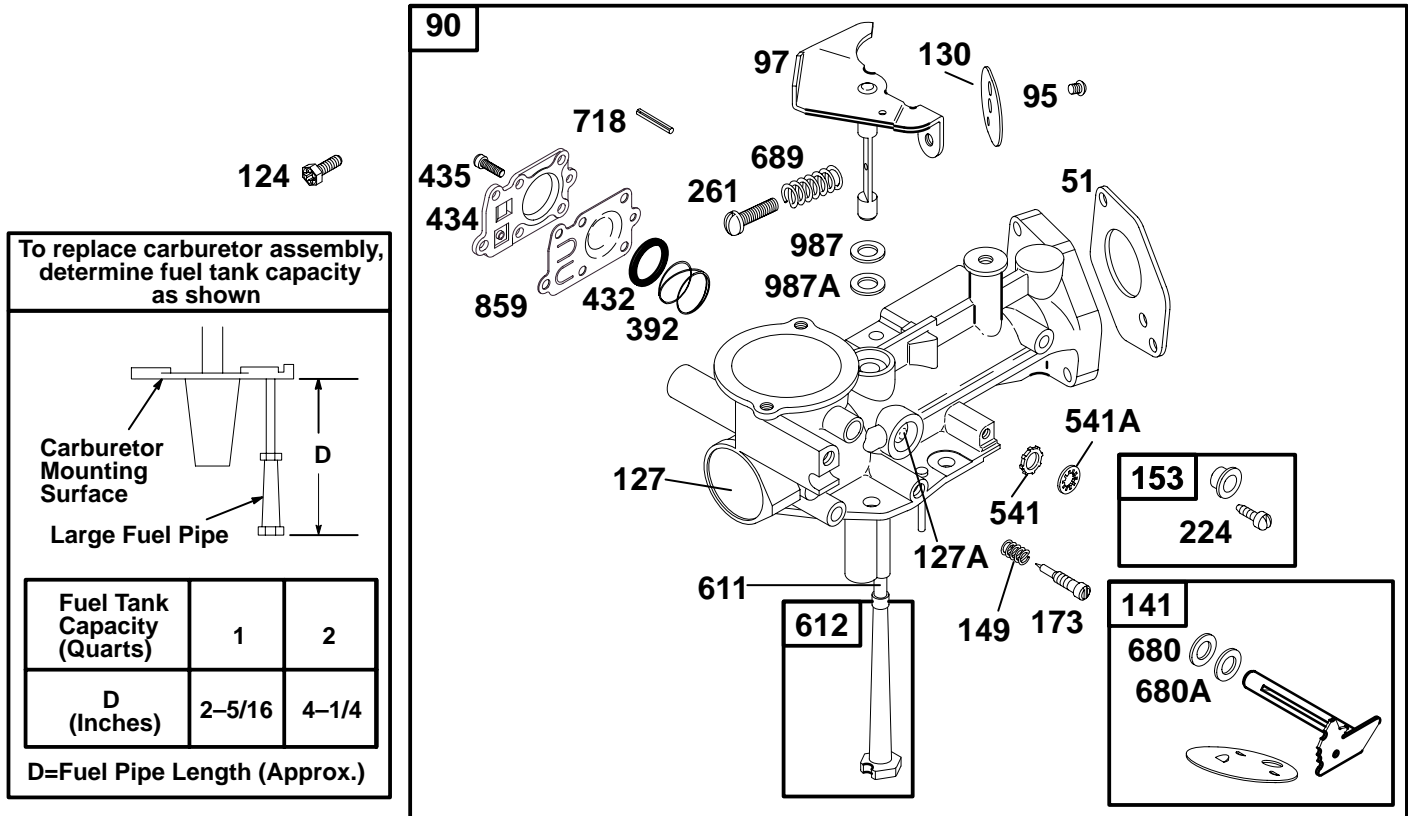

REF. NO.	PART NO.	DESCRIPTION	REF. NO.	PART NO.	DESCRIPTION	REF. NO.	PART NO.	DESCRIPTION
51	273113	Gasket-Intake	149	26336	Spring-Needle Valve	612	391813	Tube-Pick Up
90	495459	Carburetor (2 Quart Tank)	153	490501	Collar/Screw Kit	Note 297219 Tube-Pick Up Used on Type No(s). 0101, 0216.		
		Note	173	231533	Valve-Idle Adjust	680	270382	Washer (Choke Shaft)
		495461 Carburetor (1 Quart Tank)	224	93955	Screw (Collar)	680A	221839	Washer (Choke Shaft)
95	93499	Screw (Throttle Valve)	261	93527	Screw (Idle Speed Adjust)	689	260575	Spring-Friction
97	495313	Shaft-Throttle	392	262328	Spring-Pump Diaphragm	718	93265	Pin-Locating
124	94913	Screw (Carburetor Mounting)	432	221377	Cap-Spring	859	272538	Diaphragm-Pump
127	220352	Plug-Welch	434	213963	Cover-Spring	Note 270026 Diaphragm-Pump (Used Before Code Date 92090700).		
127A	223789	Plug-Welch	435	93141	Screw (Diaphragm Cover)	987	271853	Seal-Throttle Shaft
130	223793	Valve-Throttle	541	93397	Washer (Speed Adjust Lever)	987A	398970	Seal-Throttle Shaft
141	497230	Kit-Choke Shaft	541A	92507	Washer (Speed Adjust Lever)			
		Note	611	231067	Pipe-Fuel			
		491177 Kit-Choke Shaft (Used Before Code Date 94090100).						

★ Included in Gasket Set-See Ref. 358.

Ø Included in Valve Overhaul Gasket Set-Part 498524.

90200 to 90299

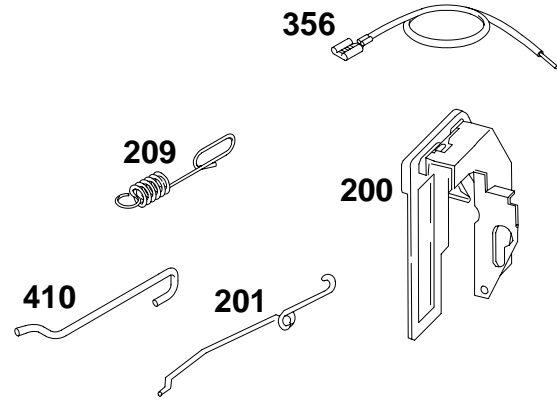
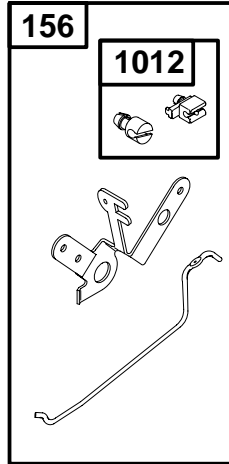
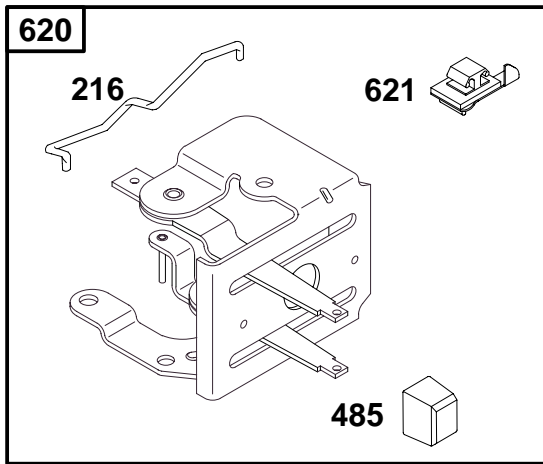
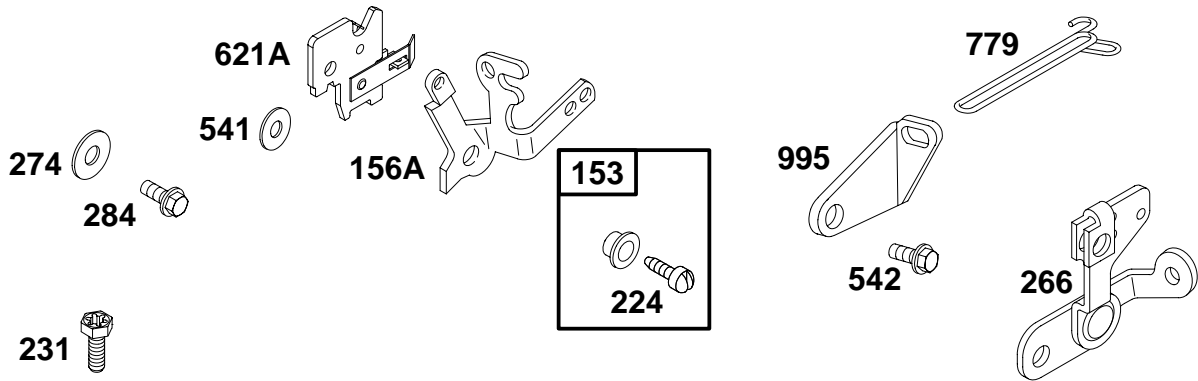

REF. NO.	PART NO.	DESCRIPTION	REF. NO.	PART NO.	DESCRIPTION	REF. NO.	PART NO.	DESCRIPTION
153	490501	Collar/Screw Kit	231	94924	Screw (Control Bracket)	542	94897	Screw (Link Bracket)
156	492905	Lever-Speed Adjusting	266	497195	Control-Throttle (Cable Casing)	620	490649	Panel-Speed Control
156A	223857	Lever-Speed Adjusting	274	66432	Washer (Cable Casing)	621	396847	Switch-Stop
200	498770	Blade-Governor	284	93543	Screw (Cable Casing)	621A	296110	Switch-Stop
201	262325	Link-Air Vane	356	398808	Wire-Stop	779	262570	Link-Bell Crank
209	262317	Spring-Governor	410	262470	Link-Control	995	225057	Bracket-Link
		Note	485	280715	Knob-Control			Note
		262392 Spring-Gov. Used on Type No(s). 0216.	541	22398	Washer (Speed Adjust Lever) (Used In Place Of Stop Switch, Ref. 621)			223887 Bracket-Link (Used Before Code Date 94090100). Used on Type No(s). 0101.
216	262359	Link-choke				1012	490507	Retainer-Link
224	93955	Screw (Collar)						

★ Included in Gasket Set-See Ref. 358.

Ø Included in Valve Overhaul Gasket Set-Part 498524.

90200 to 90299

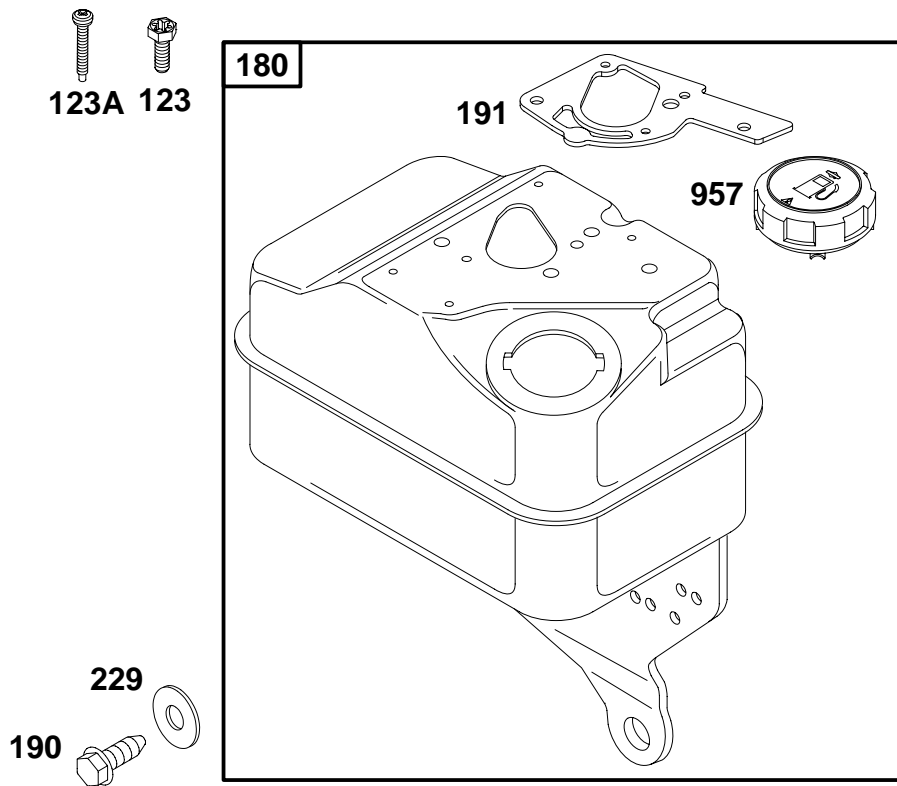

REF. NO.	PART NO.	DESCRIPTION	REF. NO.	PART NO.	DESCRIPTION	REF. NO.	PART NO.	DESCRIPTION
123	94924	Screw (Carburetor To Tank)	180	495377	Tank-Fuel (2 Quart)	191	★272489	Gasket-Fuel Tank ———— Note ———
123A	94919	Screw (Carburetor To Tank) (Used After Code Date 92090600).			———— Note ——— 495370 Tank-Fuel (1 Quart)			★272996 Gasket-Fuel Tank (Used Before Code Date 92060800).
			190	94914	Screw (Tank Mounting)	229	66432	Washer (Fuel Tank)
						957	494559	Cap-Fuel Tank

★ Included in Gasket Set—See Ref. 358.

Ø Included in Valve Overhaul Gasket Set—Part 498524.

90200 to 90299

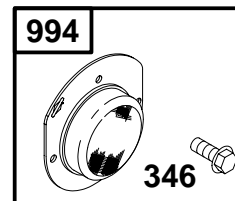
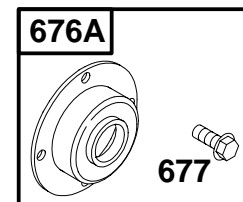
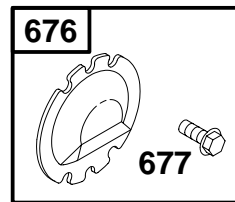
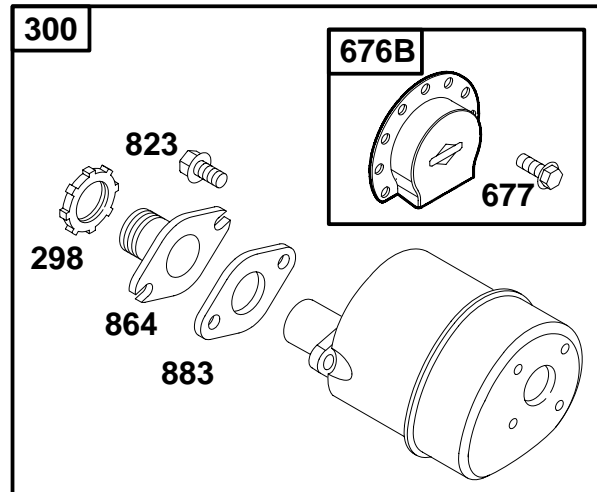
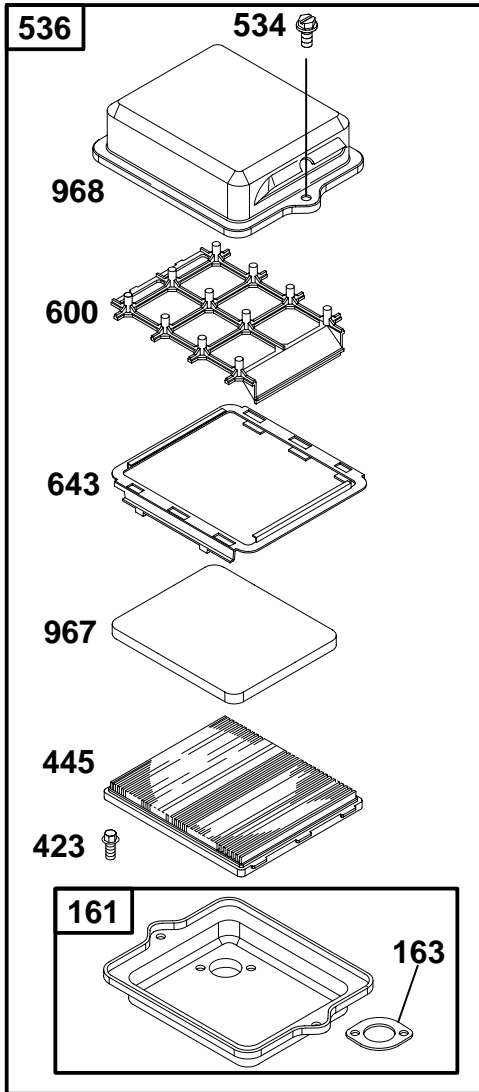

REF. NO.	PART NO.	DESCRIPTION	REF. NO.	PART NO.	DESCRIPTION	REF. NO.	PART NO.	DESCRIPTION
161	492797	Base–Air Cleaner	534	490073	Screw (Air Cleaner Cover)	823	94523	Screw (Muffler Adaptor)
163	★271935	Gasket–Air Cleaner	536	494279	Cleaner–Air	864	492232	Adapter–Muffler
298	220859	Locknut–Muffler	600	280737	Spacer–Air Filter	883	★272203	Gasket–Exhaust
300	493288	Muffler–Exhaust	643	280726	Retainer–A/C	967	491435	Filter–Pre-Cleaner
346	94896	Screw (Spark Arrestor)	676	393756	Deflector–Muffler	968	495872	Cover–Air Cleaner
423	94902	Screw (Air Cleaner Base)	676A	397931	Deflector–Muffler	994	398067	Arrester–Spark
445	491588	Filter–A/C Cartridge	676B	393760	Deflector–Muffler			
			677	94896	Screw (Muffler Deflector)			

★ Included in Gasket Set–See Ref. 358.

Ø Included in Valve Overhaul Gasket Set–Part 498524.

90200 to 90299

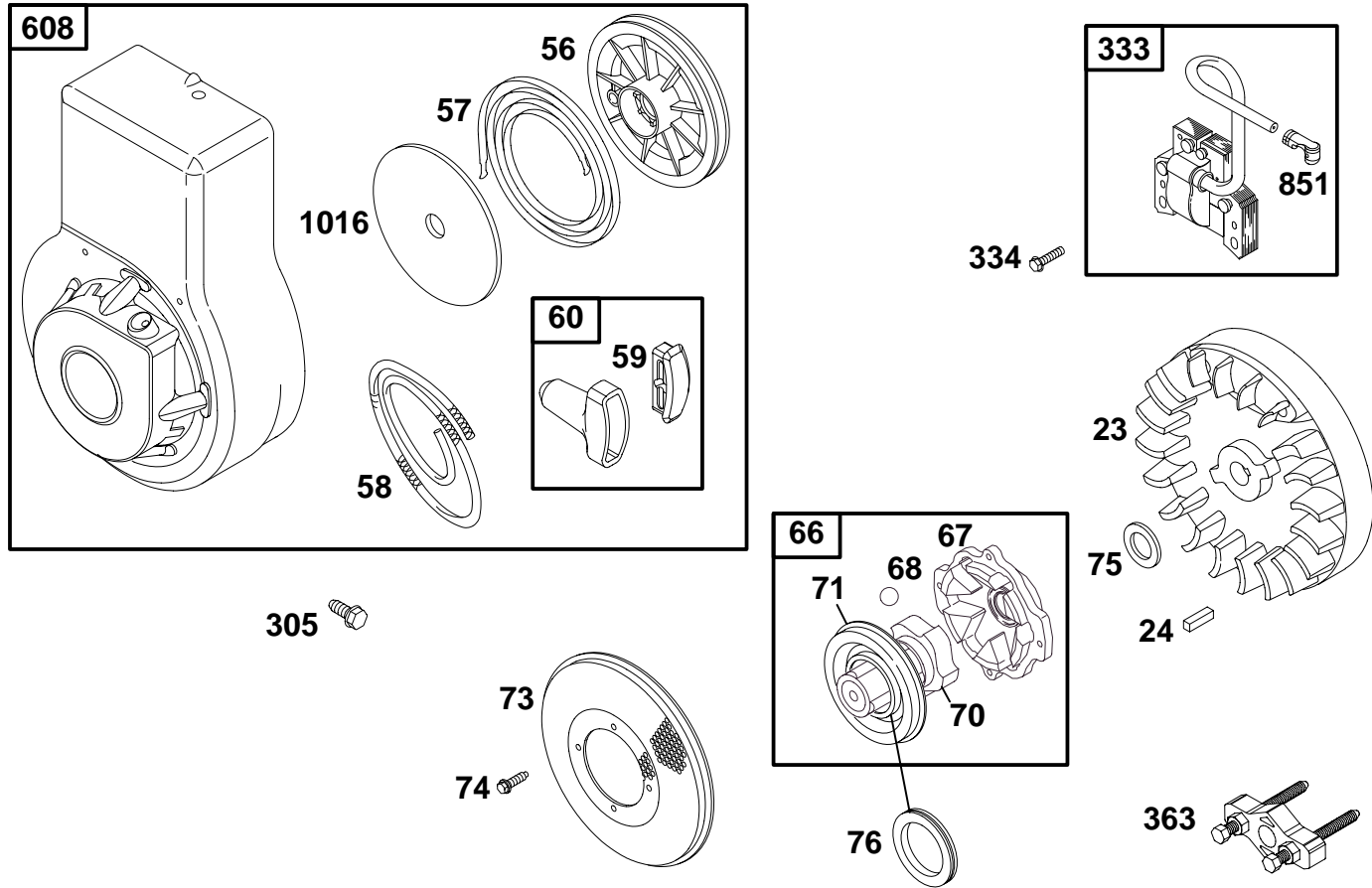

REF. NO.	PART NO.	DESCRIPTION	REF. NO.	PART NO.	DESCRIPTION	REF. NO.	PART NO.	DESCRIPTION
23	496278	Flywheel	70	298799	Ratchet-Clutch	363	19069	Flywheel Puller
24	222698	Key-Flywheel	71	394506	Cover-Ratchet	608	498007	Starter-Rewind (10 O'Clock)
56	280439	Pulley-Starter	73	221661	Screen-Rotating			Note
57	490179	Spring-Rewind Starter	74	94058	Screw (Rotating Screen)			498002 Starter-Rewind (12 O'Clock)
58	280399	Rope-Starter (Cut to Required Length)	75	223047	Washer-Flywheel			Used on Type No(s). 0100, 0101, 0216.
59	396892	Insert-Grip	76	68238	Seal	851	493880	Terminal-Cable
60	393152	Grip-Starter Rope	305	94786	Screw (Blower Housing)	1016	490817	Spacer-Rewind
66	399671	Clutch-Starter	333	496914	Armature-Magneto			
67	394897	Housing-Clutch	334	94731	Screw (Armature)			
68	63770	Ball-Clutch						

★ Included in Gasket Set-See Ref. 358.

∅ Included in Valve Overhaul Gasket Set-Part 498524.

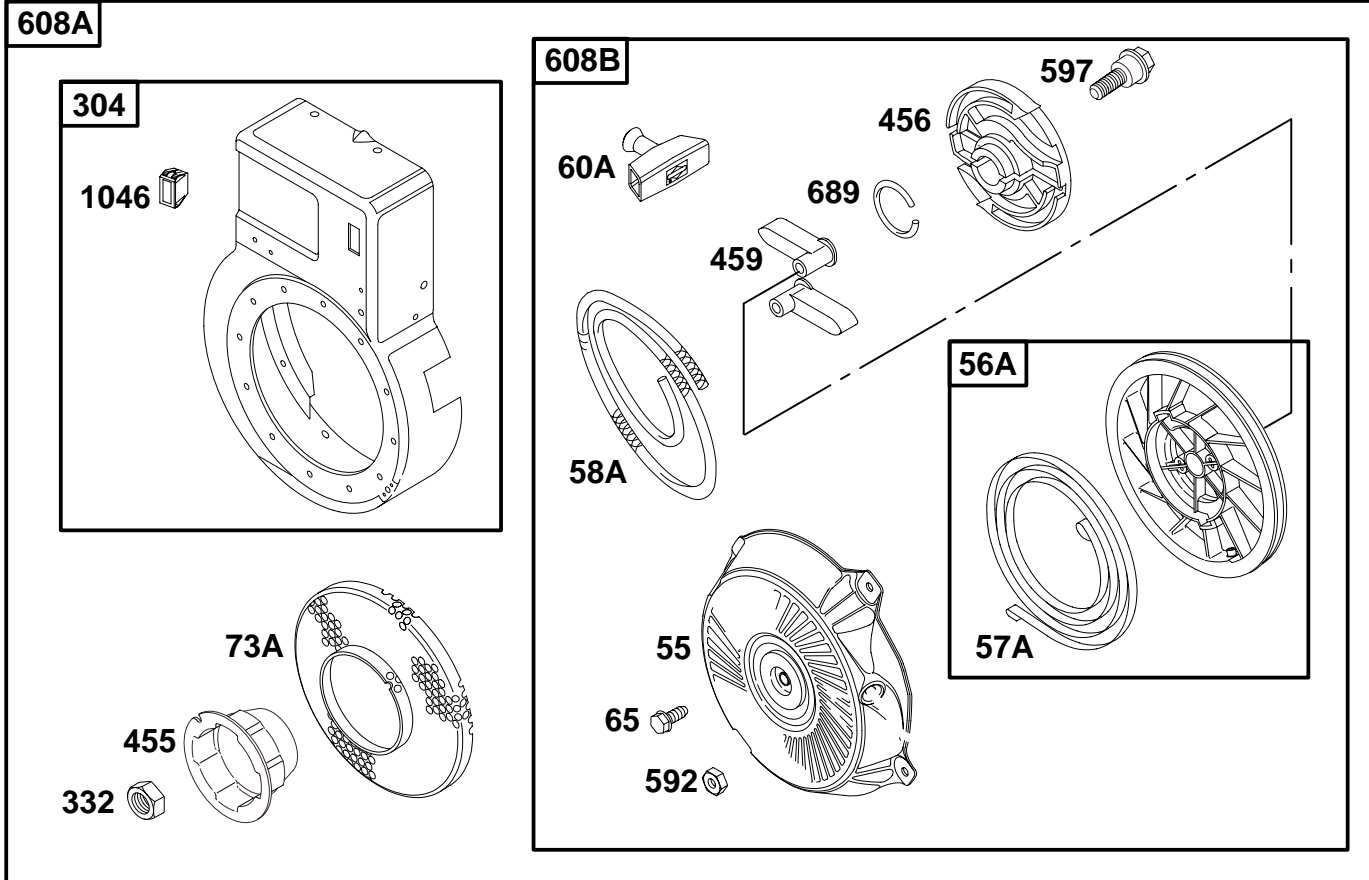

REF. NO.	PART NO.	DESCRIPTION	REF. NO.	PART NO.	DESCRIPTION	REF. NO.	PART NO.	DESCRIPTION
55	499441	Housing—Rewind Starter	304	692622	Housing—Blower	597	94943	Screw (Pawl Friction Plate)
56A	499901	Pulley—Starter	332	94877	Nut (Flywheel)	608A	690098	Starter—Rewind (Susa Replacement Kit)
57A	263074	Spring—Rewind Starter	455	225502	Cup—Flywheel	608B	690101	Starter—Rewind
58A	280399	Rope—Starter	456	281503	Plate—Pawl Friction	689	263073	Spring—Friction
60A	281101	Grip—Starter Rope	459	281505	Pawl—Ratchet	1046	281412	Plug—Blower Housing
65	94904	Screw (Rewind Starter)	592	94908	Nut (Rewind Starter)			
73A	225381	Screen—Rotating						

★ Included in Gasket Set—See Ref. 358.

Ø Included in Valve Overhaul Gasket Set—Part 498524.

90200 to 90299

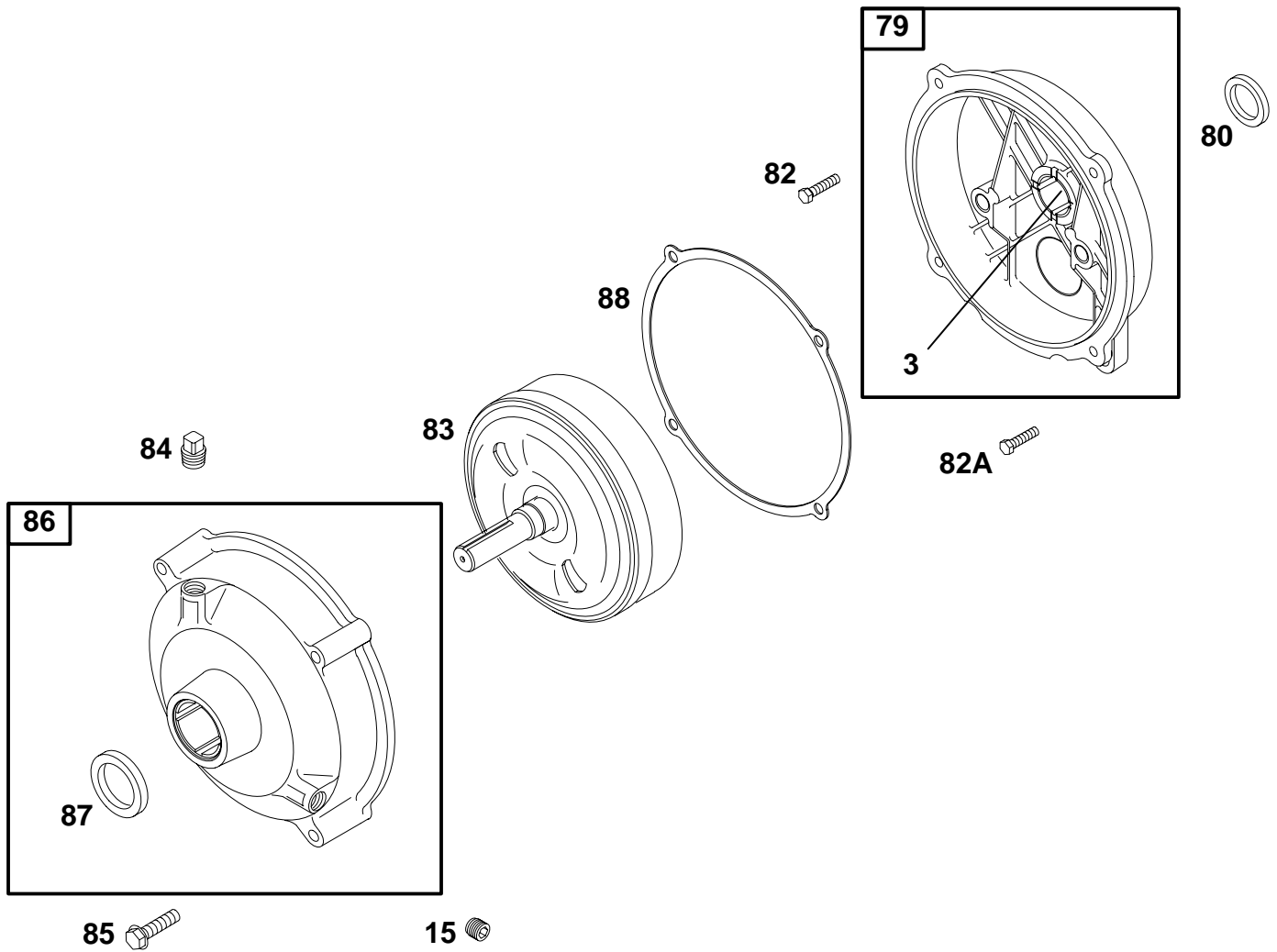

REF. NO.	PART NO.	DESCRIPTION	REF. NO.	PART NO.	DESCRIPTION	REF. NO.	PART NO.	DESCRIPTION
3	★299819	Seal-Oil	82A	94922	Screw-Hex. (Gearcase 1-1/2" Long)	85	94885	Screw (Gear Cover Assembly)
15	94886	Plug-Oil Drain	83	211293	Shaft-Auxiliary Drive	86	291730	Cover Assembly- Gear
79	290779	Case-Gear Reduction	84	94918	Plug-Breather	87	19011	Seal-Oil
80	27667	Gasket-Gear Case				88	27313	Gasket-Cover
82	94921	Screw-Hex. (Gearcase -7/8" Long)						

★ Included in Gasket Set-See Ref. 358.

Ø Included in Valve Overhaul Gasket Set-Part 498524.

90200 to 90299

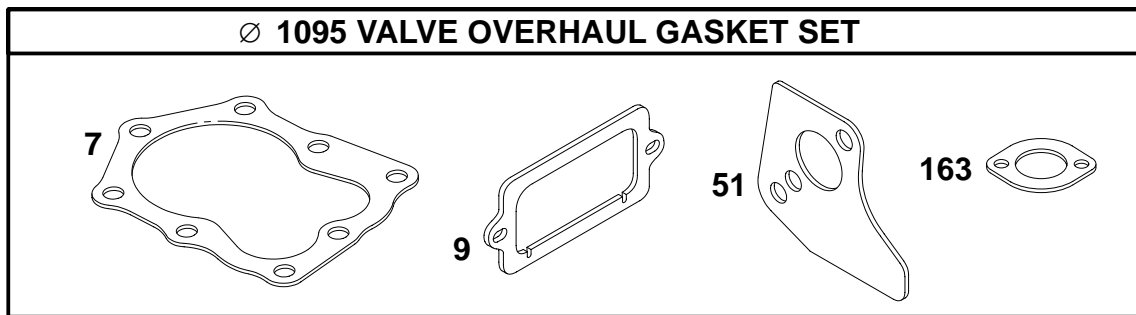
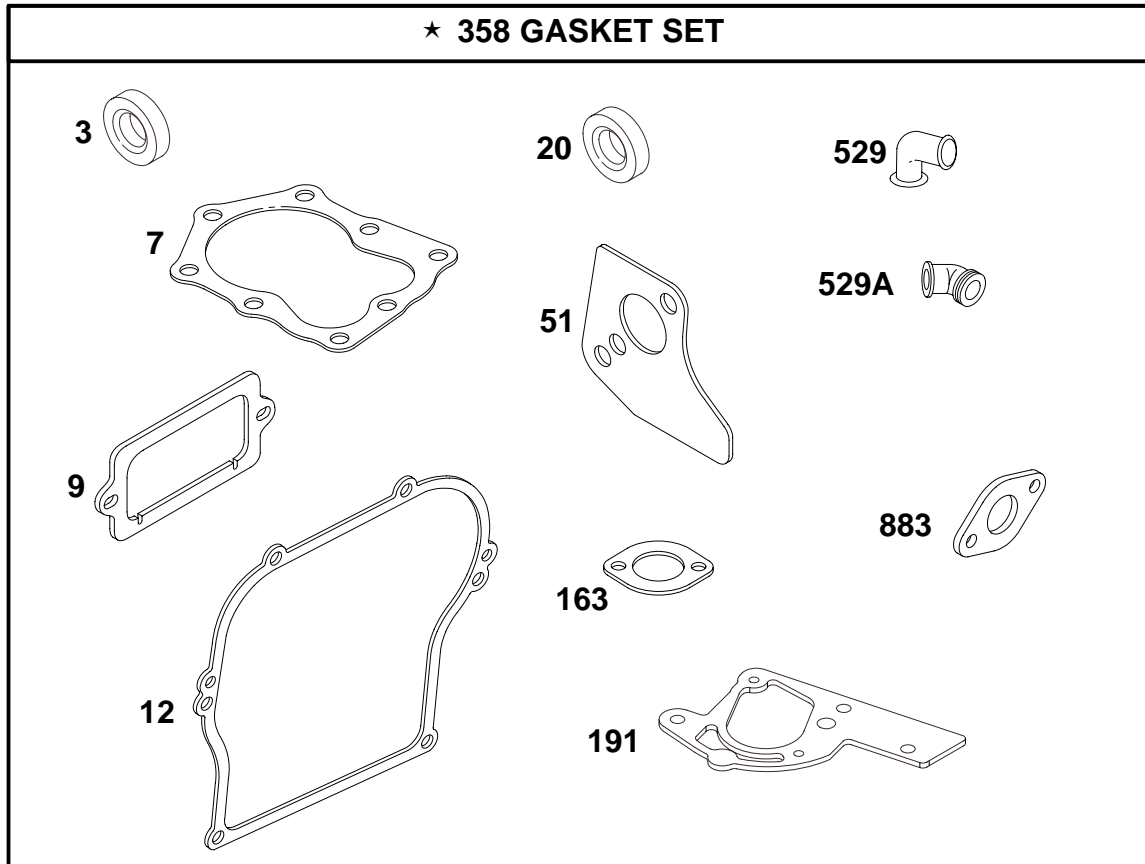

REF. NO.	PART NO.	DESCRIPTION	REF. NO.	PART NO.	DESCRIPTION	REF. NO.	PART NO.	DESCRIPTION
3	★299819	Seal-Oil	20	★299819	Seal-Oil	358	495605	Gasket Set
7	∅★272536	Gasket-Cylinder Head	51	∅★272585	Gasket-Intake			Note
9	∅★27549	Gasket-Breather	163	∅★271935	Gasket-Air Cleaner			494550 Gasket Set
12	★270833	Gasket-Crankcase (.015" Thick, Std.)	191	★272489	Gasket-Fuel Tank			(Used Before Code Date 92060800).
		Note			Note			
		★270895 Gasket-Crankcase (.005" Thick)			★272996 Gasket-Tank Mounting (Used Before Code Date 92060700).		529	★67838 Grommet
		★270896 Gasket-Crankcase (.009" Thick)					529A	★66578 Grommet
							883	★272203 Gasket-Exhaust
							1095	498524 Gasket Set-Valve Overhaul

★ Included in Gasket Set-See Ref. 358.

∅ Included in Valve Overhaul Gasket Set-Part 498524.