

290400 to 290499

Illustrated Parts List

Model Series

290400 to 290499

TYPE NUMBERS

0022 through 0035,
0040 through 0062,
0070, 0076, 0100,
0102,
0120 through 0125,
0307, 0318, 0320,
0326,
0340 through 0366,
0370 through 0378,
0382, 0385, 0390,
0391, 0394, 0398,
0402,

TYPE NUMBERS

0406 through 0454,
0457 through 0460,
0500 through 0505,
1066,
1072 through 1077,
1094, 1106, 1114,
1133, 1136, 1137,
1146 through 1149,
1152, 1153, 1154,
1157 through 1160,
1163, 1191, 1205,
1206.

TO FIND

**THE CORRECT NUMBER OF THE PART YOU NEED:
FOLLOW THE INSTRUCTIONS BELOW**

- A. Refer to Engine Model, Type and Code Number that is stamped on the blower housing of engine. Engine type numbers such as 0123 01 are listed only as 0123 in most instances. The two digits (01 or 02, etc.) to the right of the space may be required for more accurate parts identification in some instances. Select the Illustrated Parts List covering the correct Model Series and Type Number.
- B. Refer to the Illustrations and compare the original part with Illustration. The number next to the illustration is the Reference Number. Assemblies include all parts shown in frames. All parts shown in assembly frames having individual reference numbers can be purchased separately.
- C. After the Reference Number has been identified, refer to the Numerical text, where Reference and Primary Part Number are listed. **THE PRIMARY PART IS USED ON ALL TYPE NUMBERS EXCEPT THOSE TYPE NUMBERS UNDER "NOTE."**
- D. If a "Note" appears below the Primary Part Number, it means that this part differs from the Primary Part for certain types. If your Type number is listed under "Note," order the part referred to at the "Note."
- E. If your Engine Type Number does not appear after any part number listed under "Note," use the Primary Part Number.
- F. For Engine Type Numbers not covered by this book, check other Parts Lists having the same engine model or contact your source of supply.

PRINTED IN U.S.A.



COPYRIGHT by BRIGGS & STRATTON CORPORATION
All rights reserved. No part of this material may be reproduced or transmitted, in any form or by any means, electronic or mechanical, including photocopying, recording or by any information storage and retrieval system, without permission in writing from Briggs & Stratton Corporation.

290400 to 290499

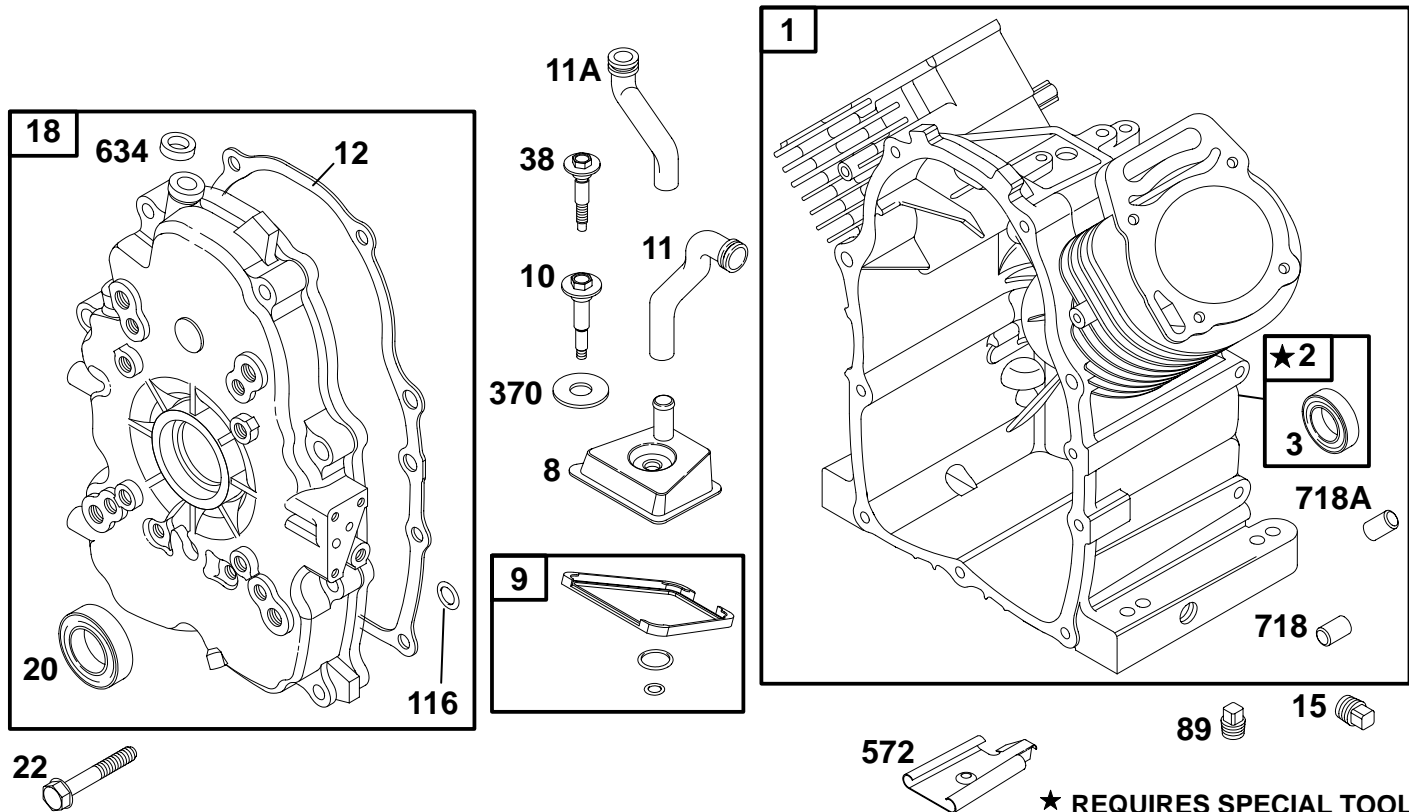

★ **REQUIRES SPECIAL TOOL TO INSTALL. SEE REPAIR INSTRUCTION MANUAL.**

1019 LABEL KIT

1058 OWNER'S MANUAL

REF. NO.	PART NO.	DESCRIPTION	REF. NO.	PART NO.	DESCRIPTION	REF. NO.	PART NO.	DESCRIPTION
1	808440	Cylinder Assembly Note 807521 Cylinder Assembly (Used Before Code Date 97050100).	12	806190	Gasket-Crankcase Note ★805112 Gasket-Crankcase (Used Before Code Date 97050100).	20	★805049	Seal-Oil
2	807687	Bushing	15	805048	Plug-Oil Drain	22	805017	Screw-Hex.
3	★805101	Seal-Oil	18	808502	Cover-Crankcase Note 807628 Cover-Crankcase (Used Before Code Date 97050100). 808506 Cover-Crankcase Used on Type No(s). 0414, 1114, 1163, 1211. 807884 Cover-Crankcase (Used Before Code Date 97050100). Used on Type No(s). 0414, 1114, 1163.	38	805194	Screw-Hex. (Used Before Code Date 90111500).
8	807795	Breather Assembly Note 807893 Breather Assembly (Used Before Code Date 90111500).				89	805059	Plug-Oil
9	★807688	Gasket-Breather				116	806191	Seal-O-Ring Note ★805198 Seal-O-Ring (Used Before Code Date 97050100).
10	805751	Screw-Shoulder				370	805484	Washer
11	806114	Tube-Breather (Used After Code Date 96101000).				572	805197	Plate-Breather
11A	805362	Tube-Breather (Used Before Code Date 96101100).				634	805416	Washer
						718	805103	Dowel-Sleeve
						718A	805102	Dowel-Sleeve (Used Before Code Date 90091100).
						1019	808035	Label Kit
						1058	272105	Owner's Manual

★ Included in Gasket Set-See Ref. 358.
● Included in Carburetor Kit-See Ref. 121.

△ Included in Valve Overhaul Kit-See Ref. 1033.

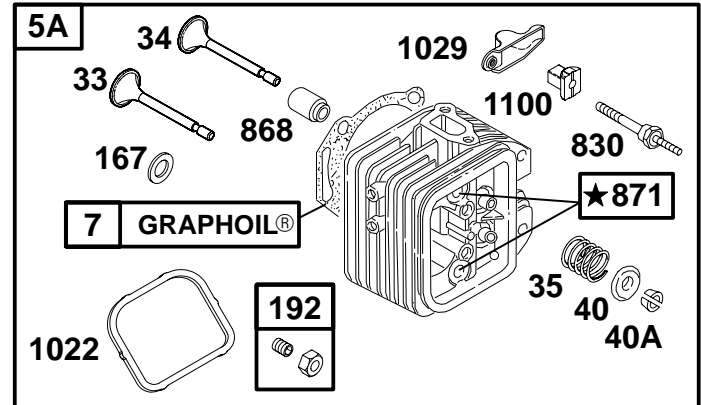
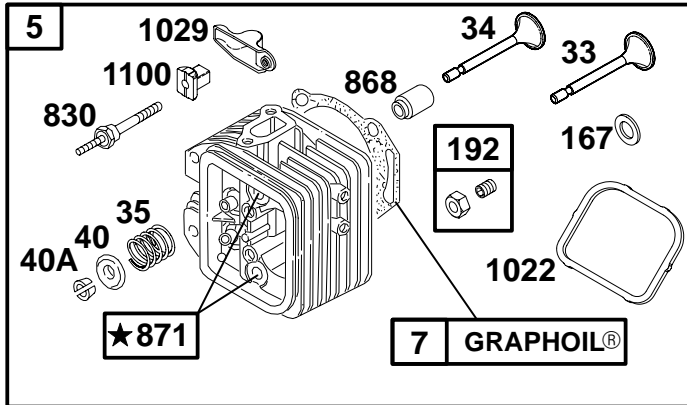
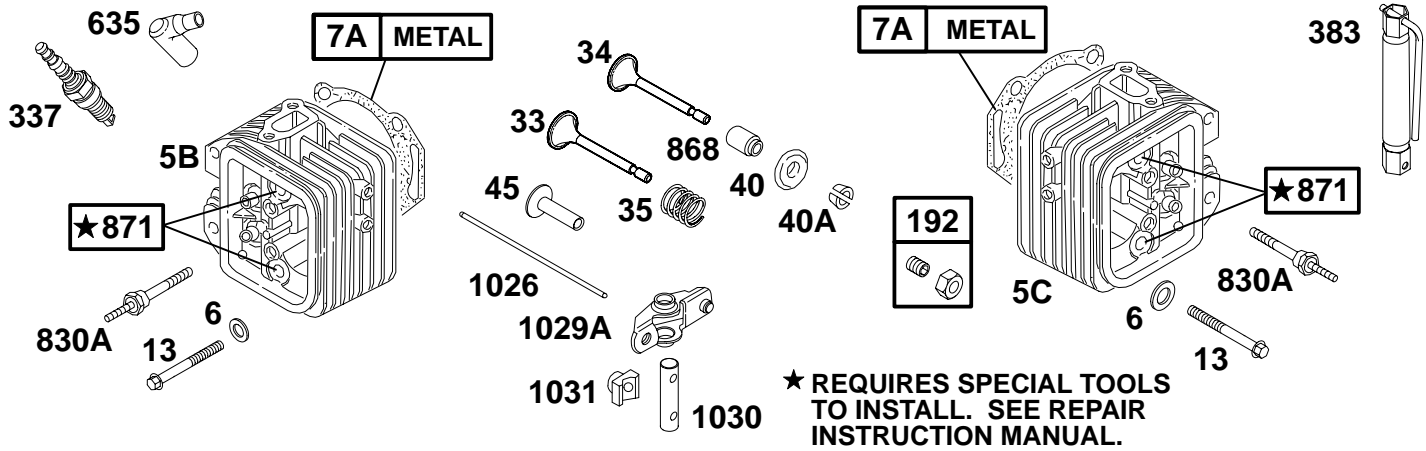

REF. NO.	PART NO.	DESCRIPTION	REF. NO.	PART NO.	DESCRIPTION	REF. NO.	PART NO.	DESCRIPTION
5	808381	Head-Cylinder #1	35	805937	Spring-Valve	1022	★Δ806039	Gasket-Rocker Cover
5A	808382	Head-Cylinder #2			Note	1026	805352	Rod-Push (Steel)
5B	807987	Head-Cylinder #1 (Used Before Code Date 96040100).			805078 Spring-Valve (Used Before Code Date 94011800).			Note
5C	807988	Head-Cylinder #2 (Used Before Code Date 96040100).	40	805092	Retainer-Valve	1029	806036	Arm-Rocker (Used After Code Date 96033100).
6	Δ805193	Washer (Used Before Code Date 94050100).	40A	807683	Retainer-Valve	1029A	808096	Arm-Rocker (Used After Code Date 96011700).
7	★Δ806085	Gasket-Cylinder Head	45	262679	Tappet-Valve			Note
7A	★Δ807986	Gasket-Cylinder Head (Used Before Code Date 96040100).	167	★Δ805420	Washer			808159 Arm-Rocker (Used Before Code Date 94011800).
13	805097	Screw-Hex.	192	807623	Screw-Valve Adj.	1030	805342	Shaft-Rocker Arm
33	807681	Valve-Exhaust	337	491055	Plug-Spark	1031	805341	Support-Rocker Arm
34	807680	Valve-Intake	383	19374	Wrench-Spark Plug	1100	806038	Pivot-Rocker Arm
			635	805529	Boot-Spark Plug			
			830	806037	Stud-Rocker Arm			
			830A	805343	Stud-Rocker Arm (Used Before Code Date 96040100).			
			868	805094	Seal-Valve			
			871	805084	Bushing-Guide			

★ Included in Gasket Set-See Ref. 358.
 ● Included in Carburetor Kit-See Ref. 121.

Δ Included in Valve Overhaul Kit-See Ref. 1033.

290400 to 290499

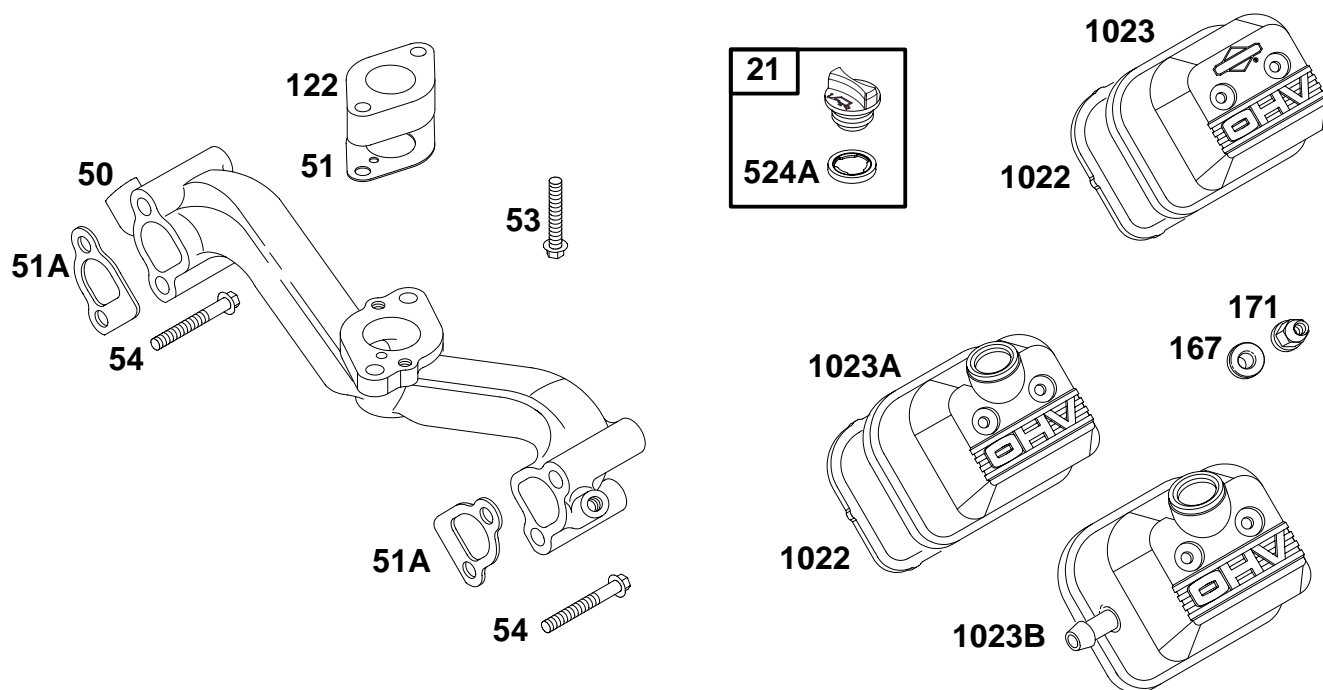

REF. NO.	PART NO.	DESCRIPTION	REF. NO.	PART NO.	DESCRIPTION	REF. NO.	PART NO.	DESCRIPTION
21	491832	Dipstick	122	805328	Spacer-Carburetor	1023B	808032	Cover-Rocker Cyl. #1 Fuel Pump Installed
50	805772	Manifold-Intake	167	★△805420	Washer			Note 805997 Cover-Rocker Used on Type No(s). 1074, 1137, 1157, 1159, 1160, 1163, 1205, 1206.
		Note 805409 Manifold-Intake (Used Before Code Date 92050100).	171	△805019	Nut-Lock			
51	★805700	Gasket-Intake	524A	★△271983	Seal-Fill Tube			
51A	★△805023	Gasket-Intake	1022	★△806039	Gasket-Rocker Cover			
53	805466	Screw-Hex.	1023	805100	Cover-Rocker			
54	805006	Screw-Hex.			Note 807665 Cover-Rocker Cyl. #1 Fuel Pump Installed			
			1023A	805842	Cover-Rocker			

★ Included in Gasket Set-See Ref. 358.
 ● Included in Carburetor Kit-See Ref. 121.

△ Included in Valve Overhaul Kit-See Ref. 1033.

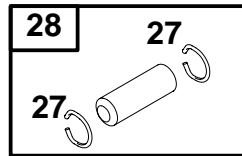
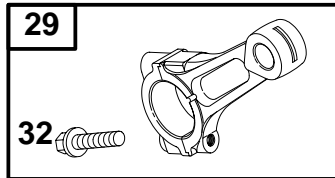
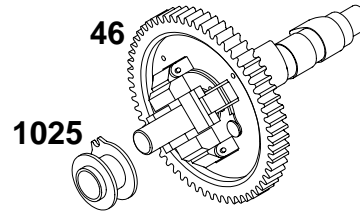
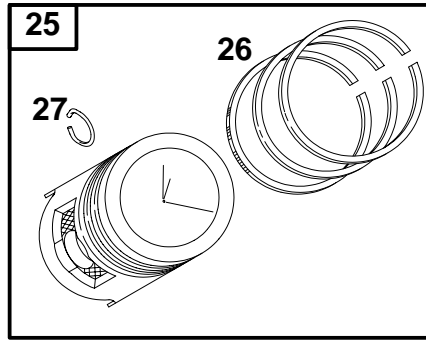

REF. NO.	PART NO.	DESCRIPTION	REF. NO.	PART NO.	DESCRIPTION	REF. NO.	PART NO.	DESCRIPTION
25	807619	Piston Assembly (Standard) _____ Note _____ 807807 Piston Assy. (.010 Oversize) 807809 Piston Assy. (.020 Oversize) 807811 Piston Assy. (.030 Oversize)	27	805099	Lock-Piston Pin	32	805395	Screw-Hex.
			28	807621	Pin-Piston	46	807542	Gear-Cam
			29	807900	Rod-Connecting (Standard) _____ Note _____ 807803 Rod-Connecting (.020 Undersize)	1025	805313	Spool-Governor
26	807620	Ring Set (Standard) _____ Note _____ 807808 Ring Set (.010 Oversize) 807810 Ring Set (.020 Oversize) 807812 Ring Set (.030 Oversize)						

★ Included in Gasket Set-See Ref. 358.
 ● Included in Carburetor Kit-See Ref. 121.

△ Included in Valve Overhaul Kit-See Ref. 1033.

290400 to 290499

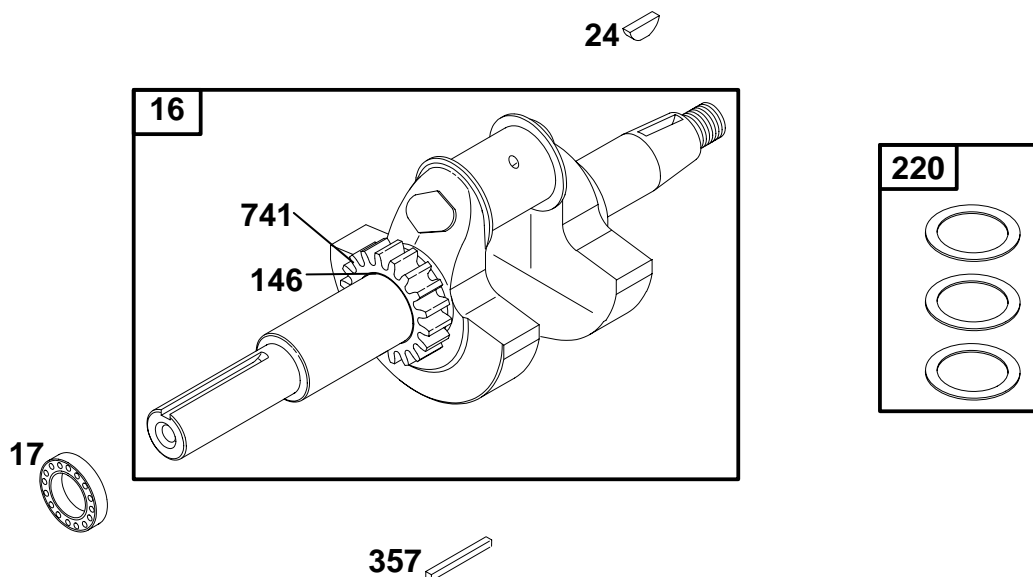

REF. NO.	PART NO.	DESCRIPTION	REF. NO.	PART NO.	DESCRIPTION	REF. NO.	PART NO.	DESCRIPTION		
16	807589	Crankshaft Note — 807590 Crankshaft Used on Type No(s). 0041, 0049, 0051, 0351, 1147, 1153. 807745 Crankshaft (Used After Code Date 89051700). Used on Type No(s). 0022, 0027, 0042, 0044, 0052, 0054, 0059, 0060, 0061, 0062, 0122, 0318, 0320, 0342, 0350, 0352, 0354, 0359, 0360, 0361, 0366, 0373, 0374, 0377, 0378, 0382, 0385, 0390, 0391, 0394, 0398, 0408, 0412, 0413, 0415, 0416, 0417, 0419, 0427, 0433, 0436, 0443, 0445, 0446, 0447, 0448, 0452, 0457, 0458, 0460, 0501, 0502, 0505, 1066, 1073, 1077, 1094, 1133, 1136, 1137, 1146, 1148, 1152, 1157, 1160, 1191, 1205, 1206.								
				807806	Crankshaft Used on Type No(s). 0124, 0407, 0421, 0429, 0451. 807849 Crankshaft Used on Type No(s). 0414, 1114, 1163. 808000 Crankshaft Used on Type No(s). 0500. 808417 Crankshaft Used on Type No(s). 1074, 1075, 1106, 1149, 1154, 1159. 808419 Crankshaft Used on Type No(s). 1077, 1137, 1146, 1157, 1160, 1205, 1206. 808422 Crankshaft Used on Type No(s). 1163.					
						17	805213	Bearing—Ball		
						24	806066	Key—Flywheel Note — 805016 Key—Flywheel (Used Before Code Date 95030100).		
						146	94196	Key—Timing		
						220	807625	Washer Set		
						357	91540	Key—Drive Pulley		
						741	805675	Gear—Timing		

★ Included in Gasket Set—See Ref. 358.
 ● Included in Carburetor Kit—See Ref. 121.

△ Included in Valve Overhaul Kit—See Ref. 1033.

290400 to 290499

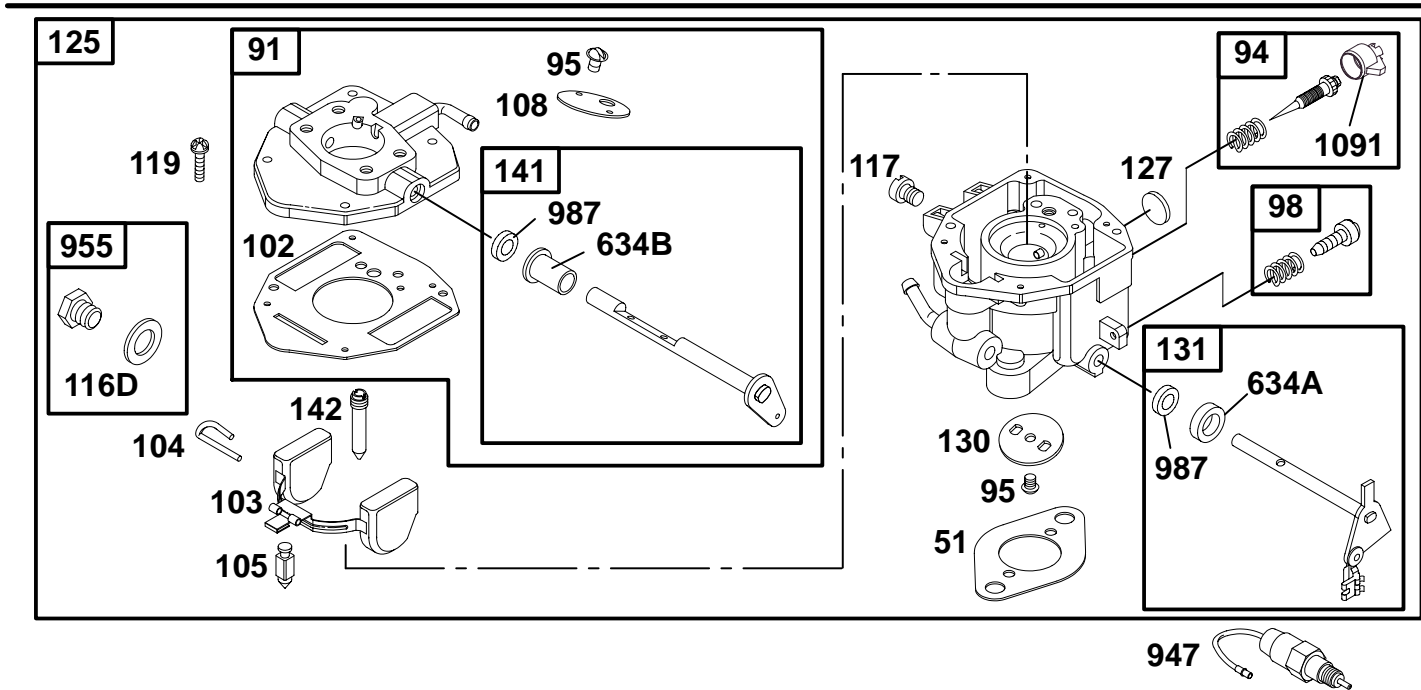

REF. NO.	PART NO.	DESCRIPTION	REF. NO.	PART NO.	DESCRIPTION	REF. NO.	PART NO.	DESCRIPTION		
51	★805700	Gasket-Intake	105	●805547	Valve-Needle (Pump Feed Carburetors)	125	808249	Carburetor (Pump Feed) (Used After Code Date 90113000).		
91	807919	Body Assembly-Upper Note 807721 Body Assy-Upper (Used Before Code Date 90120100).			Note ●805620 Valve-Needle (Gravity Feed Carburetors)			Note 807832 Carburetor (Pump Feed) (Used Before Code Date 90120100).		
94	●808257	Valve-Idle Adjustment Note ●807719 Valve-Idle Adjustment (Used Before Code Date 95010100).	108	805539	Valve-Choke	127	●805559	Plug-Welch		
95	805538	Screw-Slotted	116D	●805549	Washer-Seal	130	805554	Valve-Throttle		
98	808177	Screw-Idle Speed	117	●805852	Jet-Main (Standard) (Used After Code Date 94123100).	131	807720	Shaft-Throttle		
102	●805541	Gasket-Carburetor Body			Note ●805624 Jet-Main (Standard) (Used Before Code Date 95010100).	141	807722	Shaft-Choke		
103	805546	Float-Carburetor			●805625 Jet-Main (High Altitude) (Used After Code Date 89111700).	142	●805553	Nozzle-Carburetor		
104	●805545	Pin-Float Hinge			119	805540	Screw-Slotted	634A	●805557	Collar-Throttle
								634B	●805543	Collar-Choke Shaft
								947	807664	Solenoid-Fuel
								955	807723	Plug-Carburetor
								987	●805544	Seal-Shaft
								1091	●805862	Cap-Limiter

★ Included in Gasket Set-See Ref. 358.
● Included in Carburetor Kit-See Ref. 121.

△ Included in Valve Overhaul Kit-See Ref. 1033.

290400 to 290499

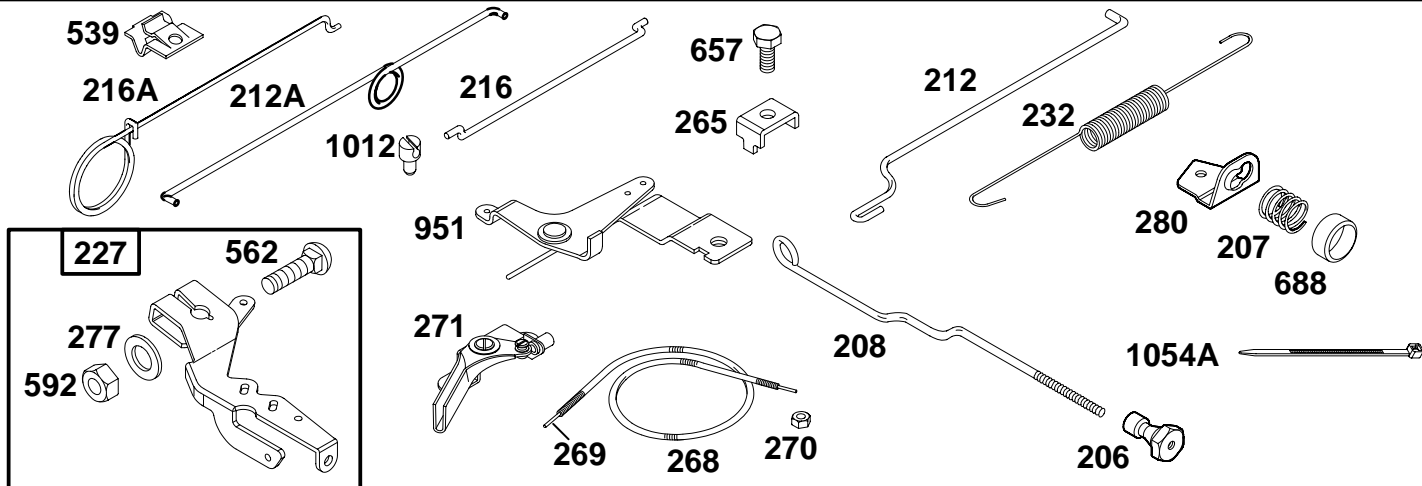

REF. NO.	PART NO.	DESCRIPTION	REF. NO.	PART NO.	DESCRIPTION	REF. NO.	PART NO.	DESCRIPTION
206	805470	Nut	216	805439	Link-choke	270	63426	Locknut-Casing
207	805473	Spring-Control Rod	216A	805509	Rod-Hand Choke	271	290568	Lever-Control
208	806080	Rod-Control (Used After Code Date 96033100).	227	807528	Lever-Governor	277	805018	Washer
		Note	232	805465	Spring-Link	280	805926	Bracket-Rod
		808453 Rod-Control (Used Before Code Date 96040100).	265	221535	Clamp-Casing			Note
		805996 Rod-Control (Used After Code Date 94113000 and Before Code Date 96040100).			22372 Clamp-Casing Used on Type No(s). 0123, 0409.			805472 Bracket-Rod (Used Before Code Date 95050100).
		805471 Rod-Control (Used Before Code Date 94120200).	268	65616	Casing-Wire (72" Long) (Cut to Required Length)	539	221372	Clip-Rod
212	805480	Link-Throttle	269	26633	Wire-Control (78" Long) (Cut to Required Length)	562	805381	Bolt-Carriage
212A	805918	Link-Throttle				592	805383	Nut
						657	805762	Screw-Hex.
						688	805485	Cap-Spring
						951	807609	Control-choke
						1012	280869	Retainer-Link
						1054A	710349	Tie-Cable

★ Included in Gasket Set-See Ref. 358.
● Included in Carburetor Kit-See Ref. 121.

△ Included in Valve Overhaul Kit-See Ref. 1033.

290400 to 290499

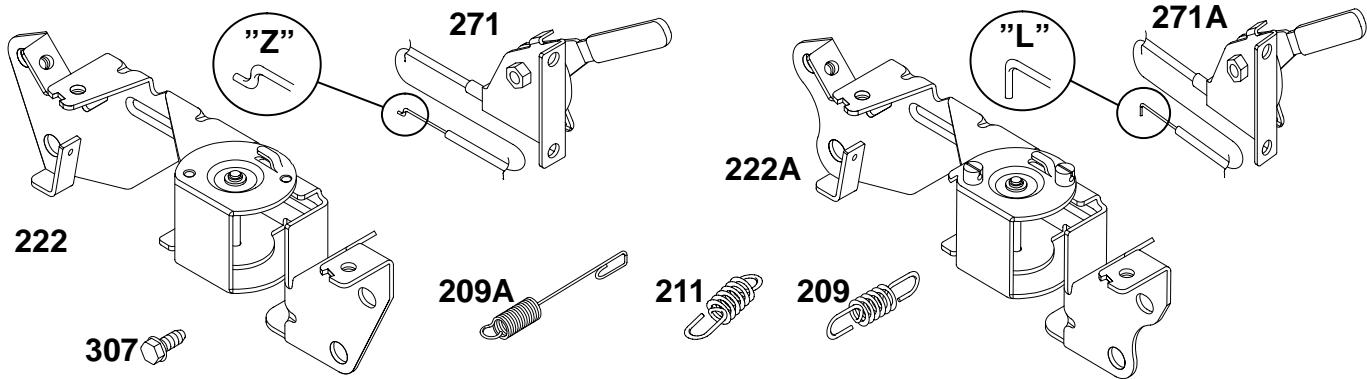

REF. NO.	PART NO.	DESCRIPTION	REF. NO.	PART NO.	DESCRIPTION	REF. NO.	PART NO.	DESCRIPTION
209	805460	Spring—Governor Note 805455 Spring—Gov. Used on Type No(s). 0022, 0042, 0044, 0052, 0342, 0352, 0378. 805456 Spring—Gov. Used on Type No(s). 0027, 0054, 0059, 0060, 0061, 0062, 0318, 0320, 0350, 0354, 0359, 0360, 0361, 0366, 0373, 0374, 0377, 0382, 0385, 0390, 0391, 0394, 0398, 0408, 0412, 0413, 0414, 0415, 0416, 0417, 0419, 0427, 0433, 0436, 0443, 0445, 0446, 0447, 0448, 0452, 0457, 0458, 0460, 0501, 0502, 0505, 1066, 1073, 1077, 1094, 1114, 0122, 1133, 1136, 1137, 1146, 1148, 1152, 1157, 1160, 1163, 1191, 1205, 1206 805459 Spring—Gov. Used on Type No(s). 0123, 0326, 0409, 0437. 805461 Spring—Gov. Used on Type No(s). 0500, 0503. 805462 Spring—Gov. Used on Type No(s). 0364, 0426.			805463 Spring—Gov. Used on Type No(s). 0407, 0425, 0441, 0451. 805464 Spring—Gov. Used on Type No(s). 0418, 0429.			805454 Spring—Governor Idler Used on Type No(s). 0326, 0437.
	209A	806060 Spring—Governor Used on Type No(s). 0327, 1210.				222	808195	Bracket—Control Note (Used With Control Lever and/or Wire With a "Z" Formed End) 807610 Bracket—Control (Used With Control Lever and/or Wire With a "Z" Formed End) (Used Before Code Date 94120100).
	211	805453 Spring—Governor Idler Note 805450 Spring—Governor Idler Used on Type No(s). 0022, 0042, 0044, 0052, 0342, 0352, 0378. 805451 Spring—Governor Idler Used on Type No(s). 0027, 0054, 0059, 0060, 0061, 0062, 0122, 0318, 0320, 0350, 0354, 0359, 0360, 0361, 0366, 0373, 0374, 0377, 0382, 0385, 0390, 0391, 0394, 0398, 0408, 0412, 0413, 0414, 0415, 0416, 0417, 0419, 0427, 0433, 0436, 0443, 0445, 0446, 0447, 0448, 0452, 0457, 0458, 0460, 0501, 1066, 1073, 1077, 1094, 1114, 1133, 1136, 1137, 1146, 1148, 1152, 1157, 1160, 1163, 1191, 1205, 1206.				222A	808115	Bracket—Control Note (Used With Control Lever and/or Wire With a "L" Formed End) 808196 Bracket—Control (Used After Code Date 95043000). Used on Type No(s). 1114, 1155, 1178. 808014 Bracket—Control (Used Before Code Date 95050100). Used on Type No(s). 0414, 0478, 1114, 1178.
						271	807763	Lever—Control (Cable Wire With a "Z" Formed End)
						271A	808118	Lever—Control (Cable Wire With a "L" Formed End)
						307	805025	Screw—Hex.

★ Included in Gasket Set—See Ref. 358.
● Included in Carburetor Kit—See Ref. 121.

△ Included in Valve Overhaul Kit—See Ref. 1033.

290400 to 290499

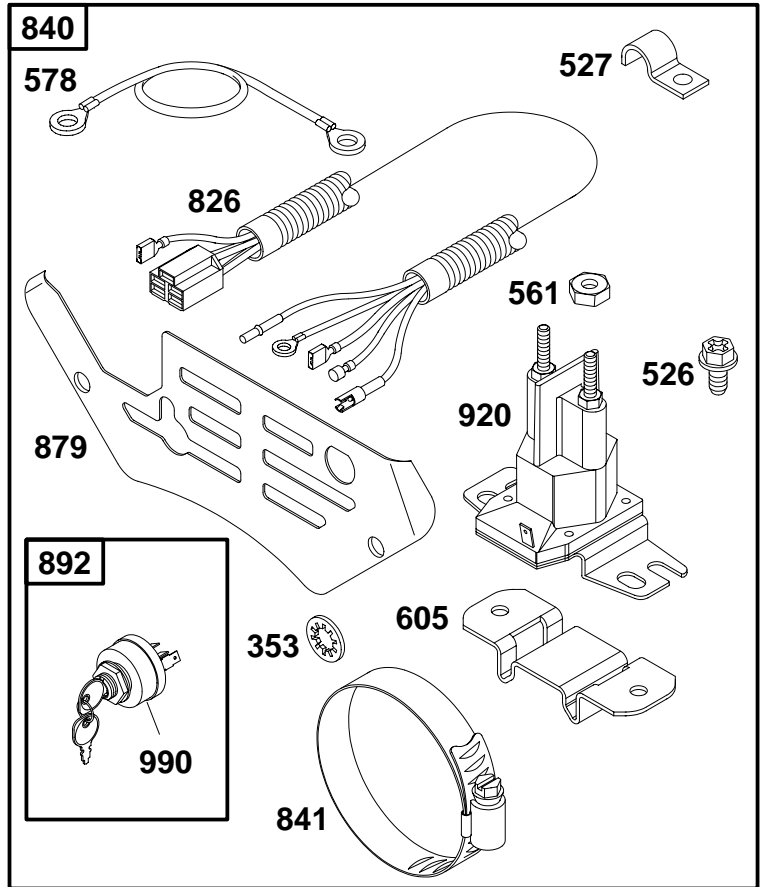
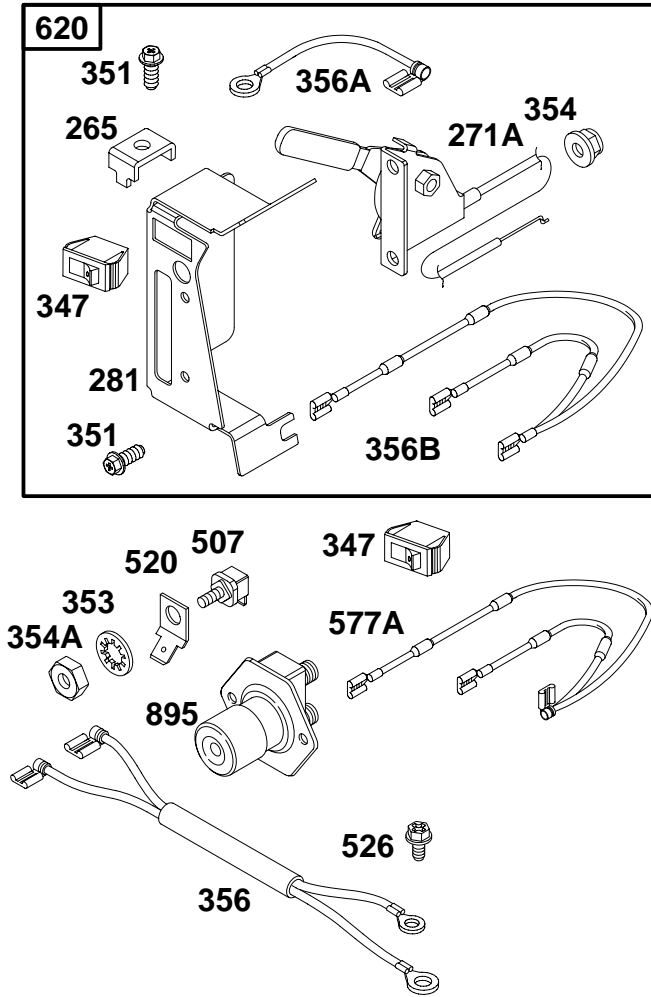

REF. NO.	PART NO.	DESCRIPTION	REF. NO.	PART NO.	DESCRIPTION	REF. NO.	PART NO.	DESCRIPTION
265	221535	Clamp-Casing	356B	493864	Wire-Stop (Ignition Coil)	620	494052	Bracket-Control (Ignition Coil)
271A	808118	Lever-Control	507	398525	Insulator	826	493624	Harness-Wiring
		Note _____	520	93722	Terminal	840	807817	Kit-Panel
		807763 Lever-Control	526	805448	Screw-Phillips Hex.	841	393514	Clamp
281	805627	Panel-Control	527	223167	Clamp-Tube	879	805841	Cover-Carburetor
347	493521	Switch-Stop	561	92278	Nut-Hex.	892	493625	Keyswitch
351	805762	Screw-Hex.	561A	93837	Nut-Hex.	895	299139	Switch-Starting
353	92791	Washer-Lock	577A	493792	Wire Assembly	920	807829	Solenoid-Starter
354	805496	Nut-Lock	578	493623	Wire Assembly	990	392832	Key Set-Starter Switch
354A	90576	Nut-Hex.	605	222934	Bracket-Mounting			
356	494771	Wire-Stop						
356A	493863	Wire-Stop						

★ Included in Gasket Set-See Ref. 358.
● Included in Carburetor Kit-See Ref. 121.

△ Included in Valve Overhaul Kit-See Ref. 1033.

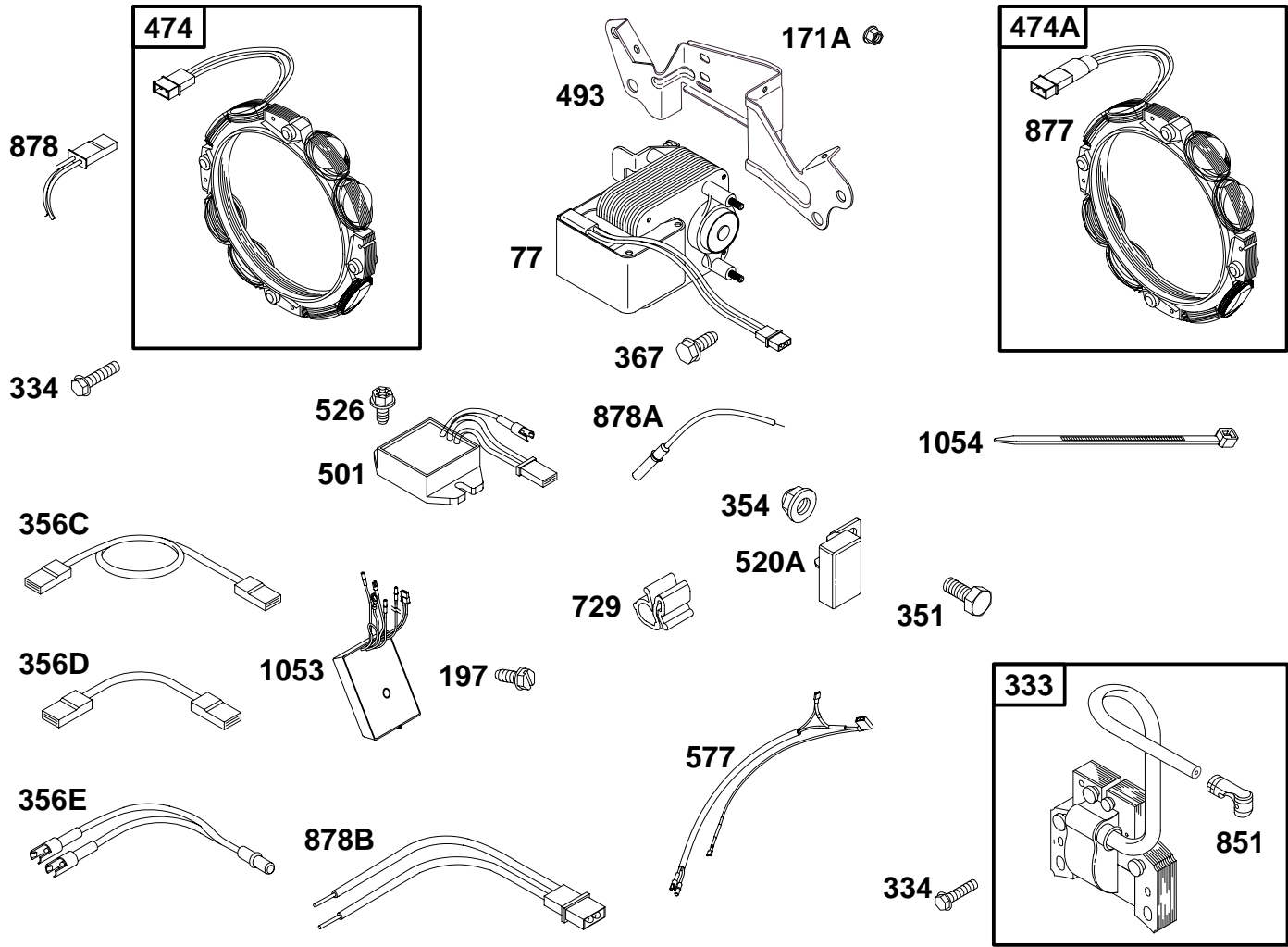

REF. NO.	PART NO.	DESCRIPTION	REF. NO.	PART NO.	DESCRIPTION	REF. NO.	PART NO.	DESCRIPTION
77	495169	Motor-Servo	356D	807594	Wire-Stop (Cylinder No. 2) (Used Before Code Date 90120200).	526	805448	Screw-Phillips Hex.
171A	94860	Nut-Hex.	356E	497296	Wire-Stop	577	494289	Wire Assembly
197	94866	Screw-Hex.	367	810036	Screw-Hex.	729	280470	Clip-Wire
333	492341	Armature-Magneto	474	393295	Alternator	851	493880	Terminal-Cable
334	805407	Screw-Hex.	474A	393474	Alternator	877	393456	Wire-Alternator
351	805762	Screw-Hex.	493	805917	Bracket-Mounting	878	393362	Harness-Alternator
354	805496	Nut-Lock	501	394890	Regulator	878A	393422	Harness-Alternator
356C	807593	Wire-Stop (Cylinder No. 1) (Used Before Code Date 90120200).	520A	807527	Terminal (Used Before Code Date 90120200).	878B	399916	Harness-Alternator
356D						1053	494994	Module
356E						1054	280275	Tie-Cable

★ Included in Gasket Set-See Ref. 358.
● Included in Carburetor Kit-See Ref. 121.

△ Included in Valve Overhaul Kit-See Ref. 1033.

290400 to 290499

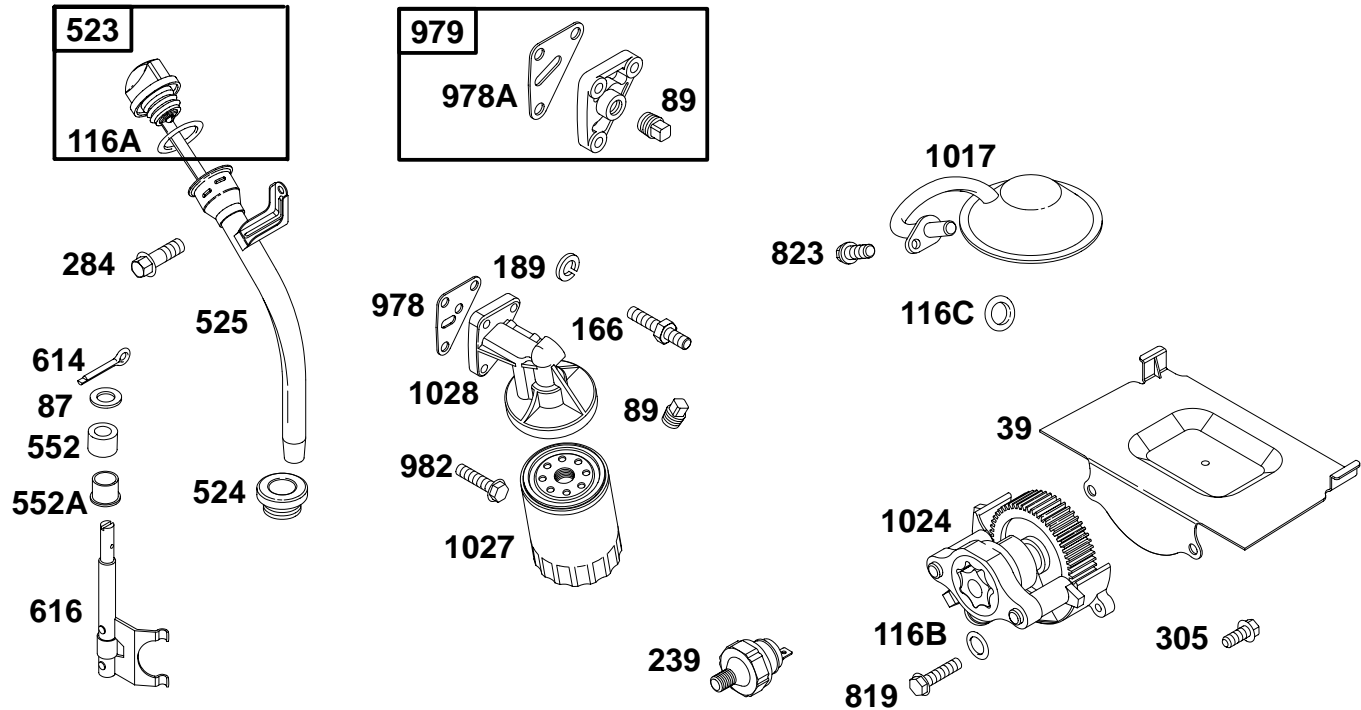

REF. NO.	PART NO.	DESCRIPTION	REF. NO.	PART NO.	DESCRIPTION	REF. NO.	PART NO.	DESCRIPTION
	39	805300 Deflector—Oil		524	★281370 Seal—Fill Tube		1024	807644 Pump—Oil
	87	★805054 Seal—Governor Shaft		525	807584 Tube—Oil Fill		1027	492932 Filter—Oil (2 1/4" Long)
	89	805059 Plug—Oil		552	805412 Bushing—Gov. Crank			———— Note ————
	116A	★805386 Seal—O-Ring		552A	805413 Bushing—Gov. Crank			491056 Filter—Oil
	116B	★805058 Seal—O-Ring (Oil Pump)		614	805417 Pin—Cotter			(3 1/4" Long)
	116C	★805316 Seal—O-Ring (Pick-Up Tube)		616	807596 Crank—Governor			(Used Before Code Date 95020600).
	166	805073 Stud—Hex. Drive		819	805057 Screw—Hex.		1028	808235 Adapter—Filter
	189	805449 Washer—Lock		823	805317 Screw—Hex.			———— Note ————
	239	491657 Switch—Oil Pressure		978	★805250 Gasket			808033 Adapter—Filter
	284	805177 Screw—Hex.		978A	★805229 Gasket			Horizontal Mounted Oil Filter
	305	805406 Screw—Hex.		979	807689 Cover—Pump			
	523	807977 Dipstick		982	805030 Screw—Hex.			
				1017	807598 Screen—Oil Pump			

★ Included in Gasket Set—See Ref. 358.
● Included in Carburetor Kit—See Ref. 121.

△ Included in Valve Overhaul Kit—See Ref. 1033.

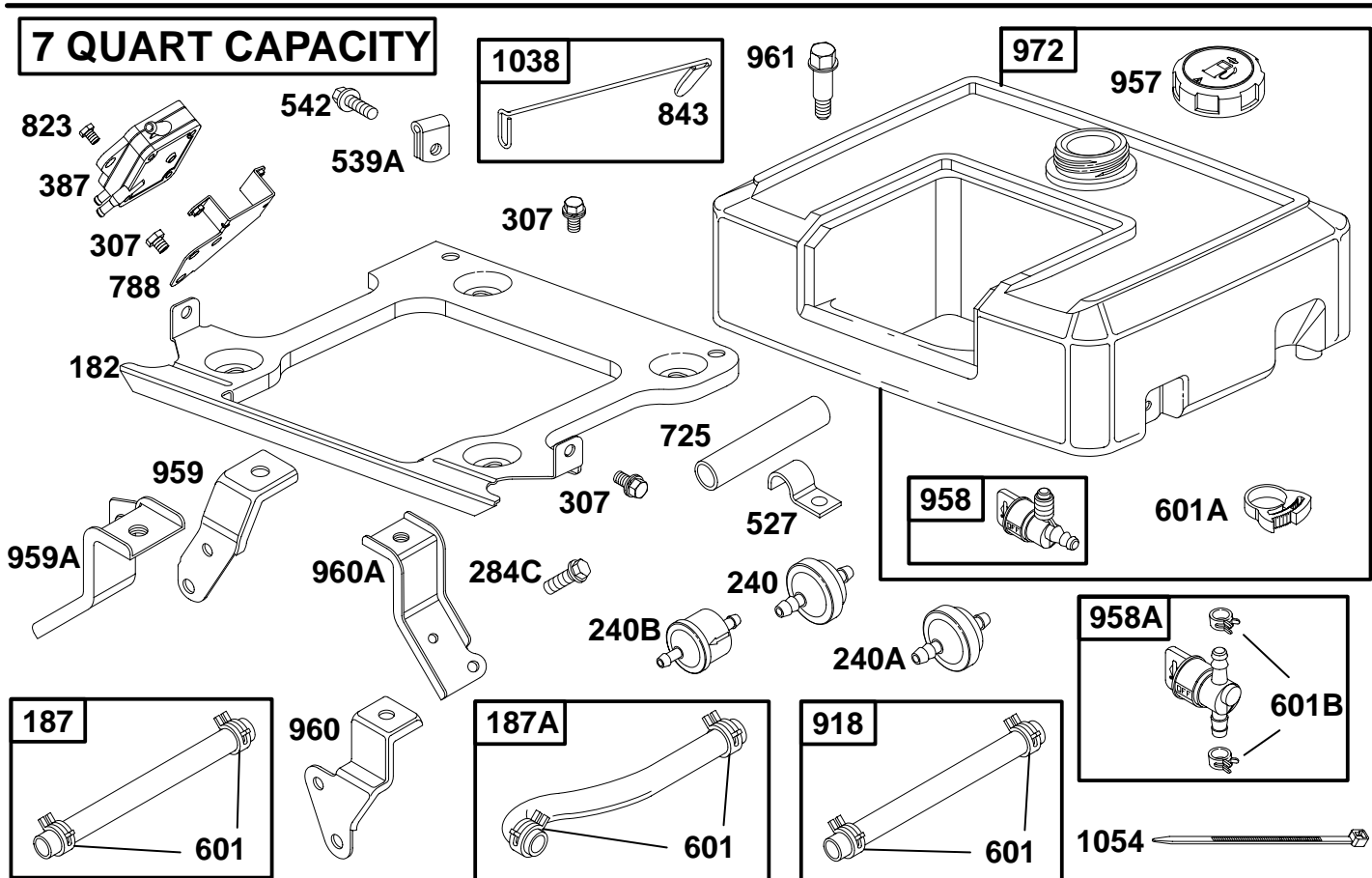

REF. NO.	PART NO.	DESCRIPTION	REF. NO.	PART NO.	DESCRIPTION	REF. NO.	PART NO.	DESCRIPTION
182	492317	Bracket-Fuel Tank	601	93053	Clamp-Hose	957	491367	Cap-Fuel Tank (Plastic)
187	492790	Line-Fuel	601A	805813	Clamp-Hose	958	399517	Valve-Shut-Off
187A	398367	Line-Fuel (Molded)	601B	93807	Clamp-Fuel Line	958A	494768	Valve-Shut-Off
240	298090	Filter-Fuel (Red)	725	280866	Shield-Heat (Cut to Required Length)	959	492318	Bracket-Fuel Tank
240A	394358	Filter-Fuel (White)	788	807685	Bracket-Pump	959A	492320	Bracket-Fuel Tank
240B	493629	Filter-Fuel	823	805317	Screw-Hex.	960	492319	Bracket-Fuel Tank
284C	805247	Screw-Hex.	843	280643	Sleeve-Lever	960A	492321	Bracket-Fuel Tank
307	805025	Screw-Hex.	918	393815	Hose-Vacuum (Rocker Cover-To-Impulse Pump) (Cut to Required Length)	961	94536	Screw-Shoulder
387	808322	Pump-Fuel				972	492369	Tank-Fuel (Plastic)
527	223167	Clamp-Tube				1038	492374	Rod-Fuel Shut-Off
539A	94484	Clamp				1054	280275	Tie-Cable
542	94504	Screw-Hex.						

★ Included in Gasket Set-See Ref. 358.
● Included in Carburetor Kit-See Ref. 121.

△ Included in Valve Overhaul Kit-See Ref. 1033.

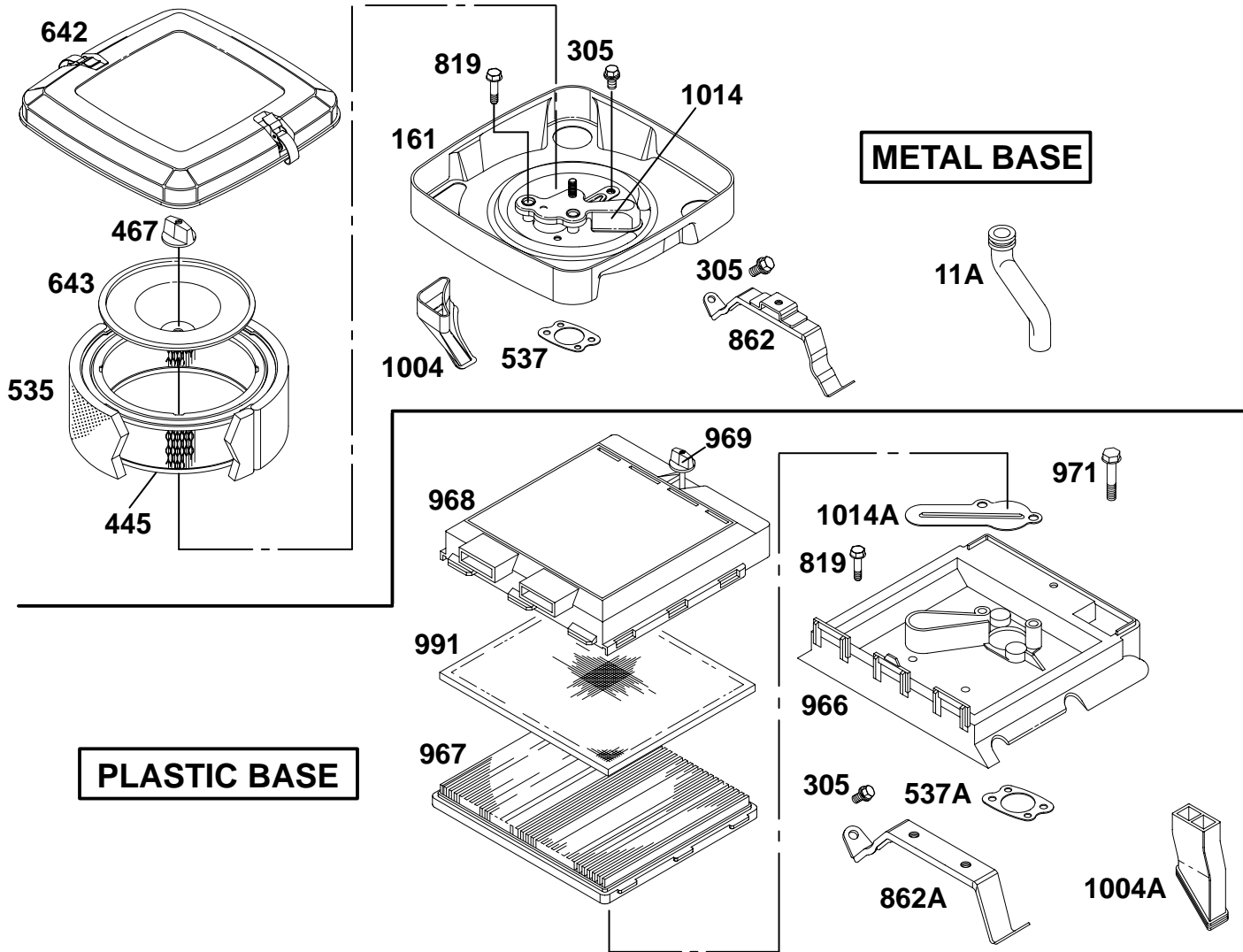

REF. NO.	PART NO.	DESCRIPTION	REF. NO.	PART NO.	DESCRIPTION	REF. NO.	PART NO.	DESCRIPTION
11A	805362	Tube-Breather (Used Before Code Date 96101100).	642	807862	Cover-Air Cleaner	968	805359	Cover-Air Cleaner
161	807857	Base-Air Cleaner	643	805631	Retainer-Air Filter	969	807565	Screw-Wing
305	805406	Screw-Hex.	819	805057	Screw-Hex.	971	805405	Screw-Hex.
445	394018	Filter-Air	862	807796	Strap-Cleaner Mounting	991	805267	Filter-Air
467	491875	Knob	862A	807563	Strap-Cleaner Mounting	1004	805632	Duct-Air
535	272490	Filter-Air	966	807564	Base-Air Cleaner	1004A	805363	Duct-Air
537	★805655	Gasket-Air Cleaner	967	805113	Filter-Air	1014	807797	Shield-Carburetor
537A	★805003	Gasket-Air Cleaner				1014A	805370	Shield-Carburetor

★ Included in Gasket Set-See Ref. 358.
● Included in Carburetor Kit-See Ref. 121.

△ Included in Valve Overhaul Kit-See Ref. 1033.

290400 to 290499

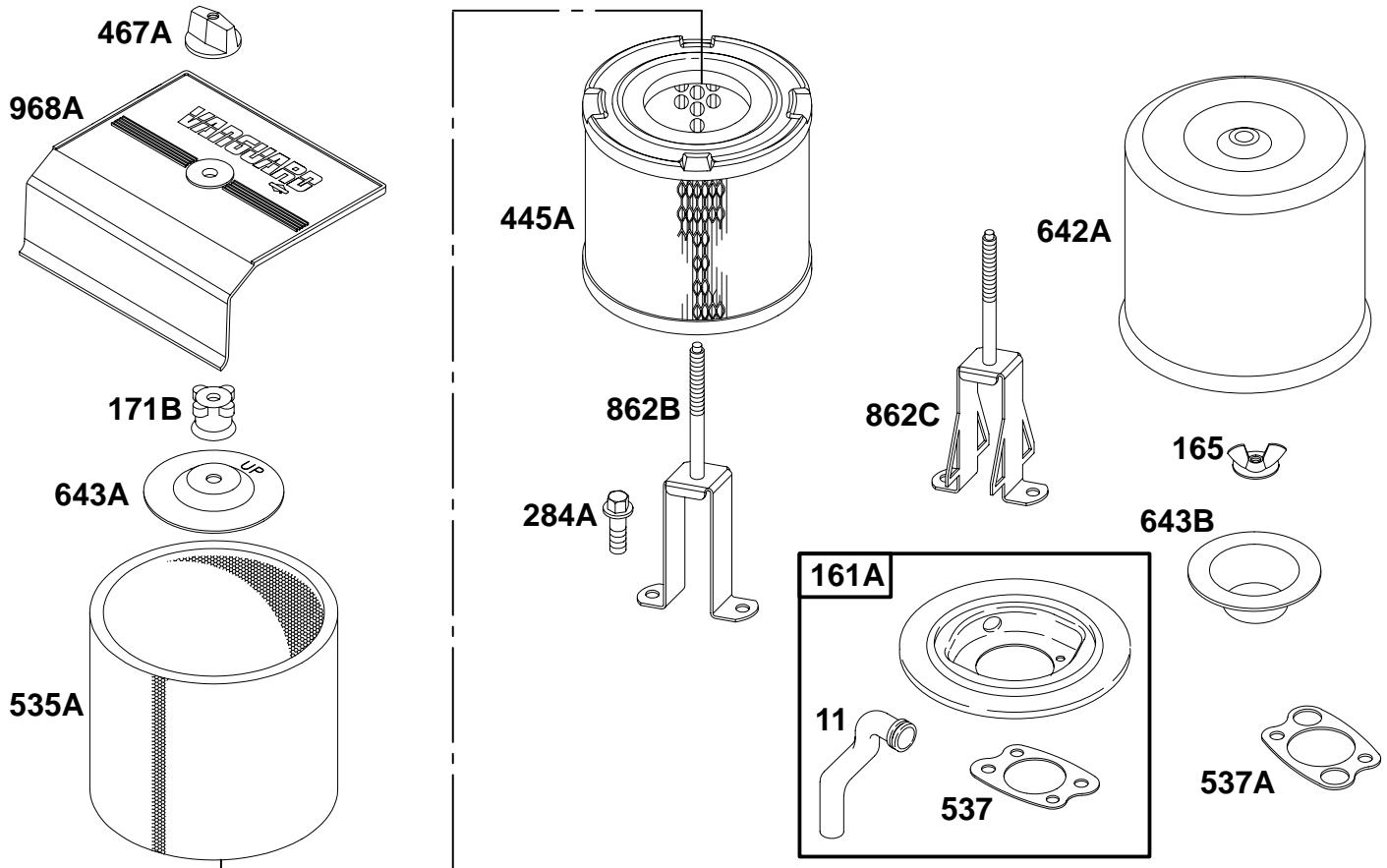

REF. NO.	PART NO.	DESCRIPTION	REF. NO.	PART NO.	DESCRIPTION	REF. NO.	PART NO.	DESCRIPTION
11	806114	Tube—Breather (Used After Code Date 96101000).	165	94289	Nut—Wing	643A	224198	Retainer—Air Filter
161A	808414	Base—Air Cleaner (Used After Code Date 96101000). Note 808117 Base—Air Cleaner (Used Before Code Date 96101100).	171B	281051	Nut	643B	222272	Retainer—Air Filter
			284A	810037	Screw—Hex.	862B	492133	Strap—Cleaner Mounting
			445A	393957	Filter—Air	862C	808113	Strap—Cleaner Mounting
			467A	493903	Knob	968A	280903	Cover—Air Cleaner
			535A	271794	Filter—Air			
			537	★805655	Gasket—Air Cleaner			
			537A	★805003	Gasket—Air Cleaner			
			642A	224885	Cover—Air Cleaner			

★ Included in Gasket Set—See Ref. 358.
● Included in Carburetor Kit—See Ref. 121.

△ Included in Valve Overhaul Kit—See Ref. 1033.

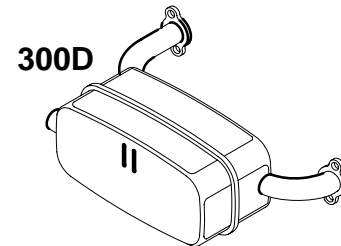
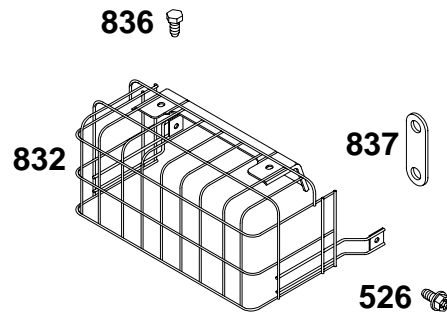
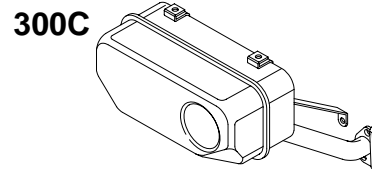
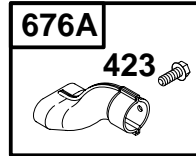
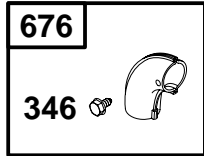
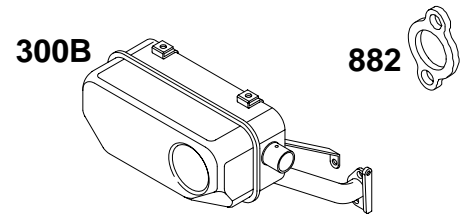
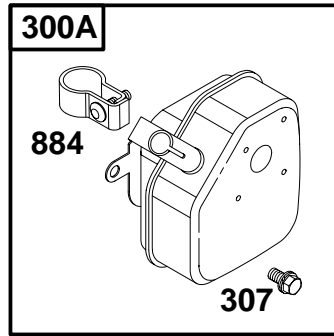
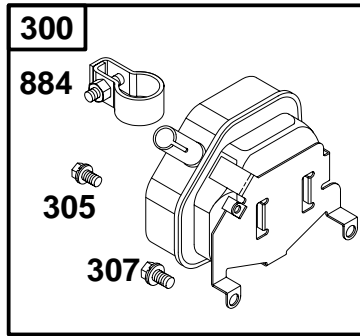

REF. NO.	PART NO.	DESCRIPTION	REF. NO.	PART NO.	DESCRIPTION	REF. NO.	PART NO.	DESCRIPTION
300	807741	Muffler-Exhaust (Used With Manifold 805378)	305	805406	Screw-Hex.	832	808227	Guard-Muffler
300A	807742	Muffler-Exhaust Used With Manifold 805142	307	805025	Screw-Hex.			Note
300B	807965	Muffler-Exhaust	346	810079	Screw-Hex.			808009 Guard-Muffler (Used Before Code Date 96042400).
300C	807964	Muffler-Exhaust	423	805260	Screw-Phillips Hex.	836	805849	Screw-Hex.
300D	808340	Muffler-Exhaust	526	805448	Screw-Phillips Hex.	837	808085	Spacer (Includes 2)
			676	495518	Deflector-Muffler	882	805502	Flange-Exhaust
			676A	808393	Deflector-Muffler	884	807595	Clamp-Muffler

★ Included in Gasket Set-See Ref. 358.
● Included in Carburetor Kit-See Ref. 121.

△ Included in Valve Overhaul Kit-See Ref. 1033.

290400 to 290499

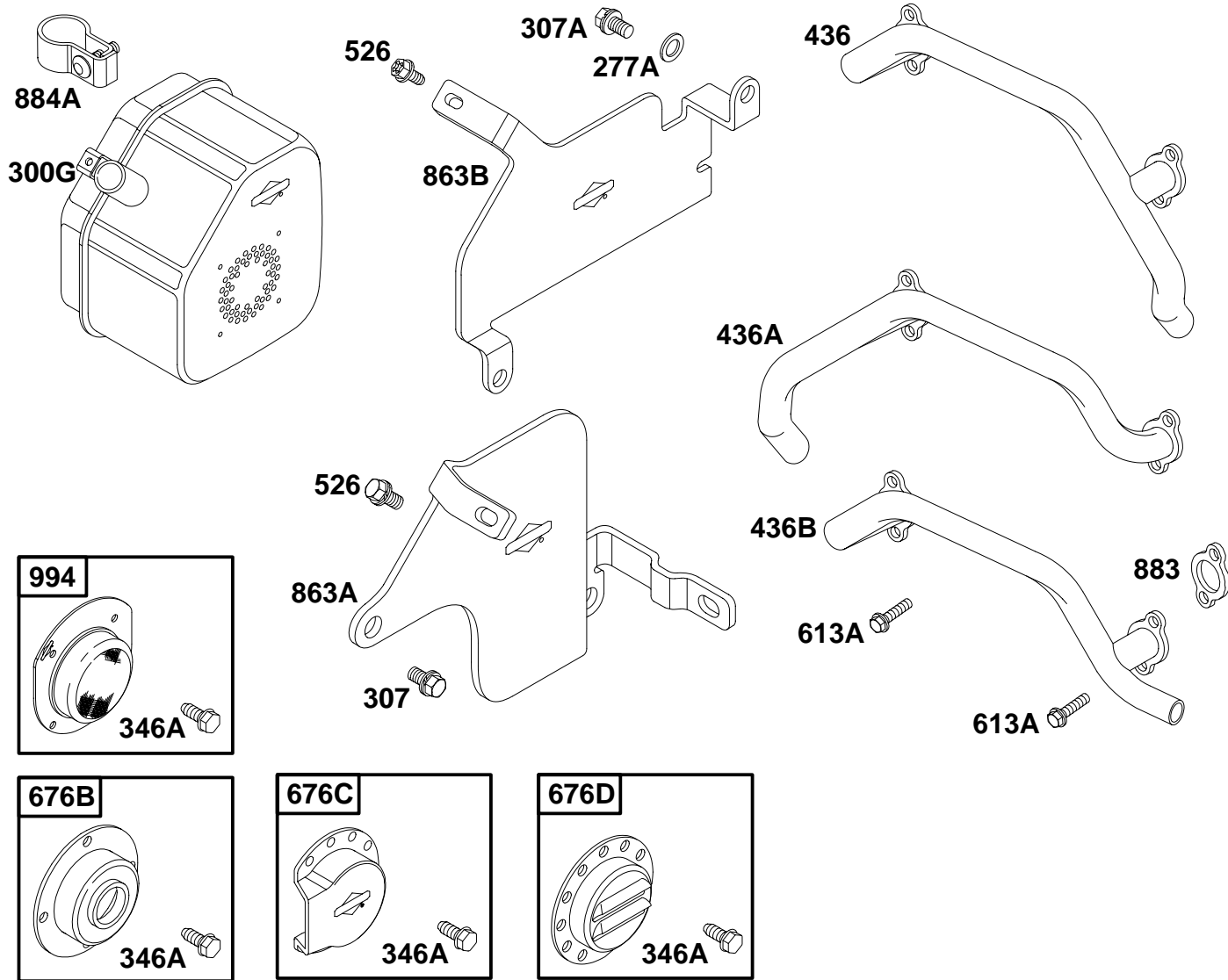

REF. NO.	PART NO.	DESCRIPTION	REF. NO.	PART NO.	DESCRIPTION	REF. NO.	PART NO.	DESCRIPTION	
277A	810108	Washer	436B	805403	Manifold-Exhaust (Muffler Supplied By Customer)	863B	805811	Bracket-Muffler	
300G	807948	Muffler-Exhaust		526	805448	Screw-Phillips Hex.	883	★△805024	Gasket-Exhaust
307	805025	Screw-Hex.		613A	805158	Screw-Hex.	884A	392649	Clamp-Muffler
307A	810107	Screw-Socket		676B	396903	Deflector-Muffler	994	392390	Arrester-Spark
346A	93705	Screw-Hex.		676C	393761	Deflector-Muffler			
436	805142	Manifold-Exhaust (Used With Muffler 807742)		676D	397630	Deflector-Muffler			
436A	805378	Manifold-Exhaust (Used With Muffler 807741)		863A	805812	Bracket-Muffler			

★ Included in Gasket Set-See Ref. 358.
● Included in Carburetor Kit-See Ref. 121.

△ Included in Valve Overhaul Kit-See Ref. 1033.

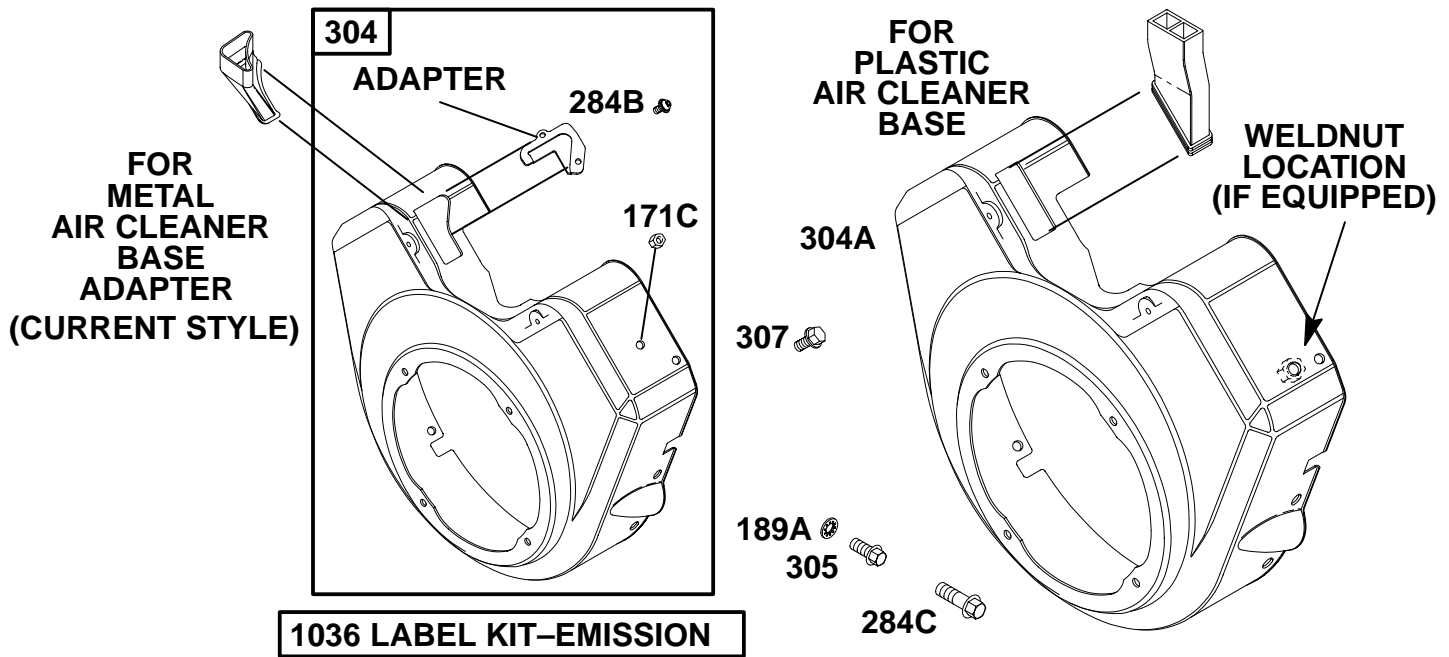

REF. NO.	PART NO.	DESCRIPTION	REF. NO.	PART NO.	DESCRIPTION	REF. NO.	PART NO.	DESCRIPTION
171C	810056	Nut-Hex.		807820	Housing-Blower (Red Without Weld Nut)			(Black With Weld Nut)
189A	806101	Washer-Lock		807892	Housing-Blower (Red Without Weld Nut)	305	805406	Screw-Hex.
284B	93410	Screw-Hex.		808008	Housing-Blower (Red With Weld Nut)	307	805025	Screw-Hex.
304	808055	Housing-Blower (Red Without Weld Nut)		807654	Housing-Blower (Red With Weld Nut)			Note
		Note		807891	Housing-Blower (Black Without Weld Nut)			805247 Screw-Hex.
		808408 Housing-Blower (Black Without Weld Nut)		807662	Housing-Blower	1036	499365	Label Kit-Emission
304A	807814	Housing-Blower (Black Without Weld Nut)						Used on Type No(s). 1066, 1072, 1073, 1074, 1075, 1076, 1077, 1094, 1106, 1114, 1133, 1136, 1137, 1146, 1147, 1148, 1149, 1152, 1153, 1154, 1157, 1159, 1160, 1163, 1191, 1205, 1206.
		Note						
		807891 Housing-Blower (Black Without Weld Nut) (Used Before Code Date 90111700).						

★ Included in Gasket Set-See Ref. 358.
 ● Included in Carburetor Kit-See Ref. 121.

△ Included in Valve Overhaul Kit-See Ref. 1033.

290400 to 290499

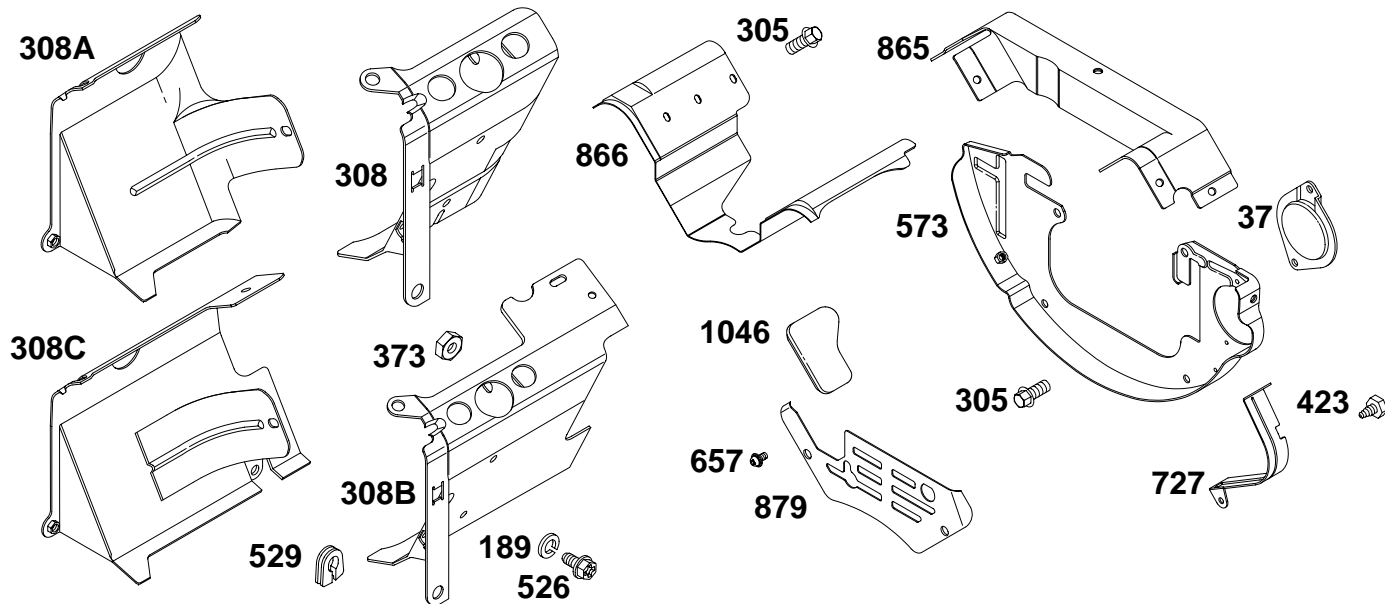

REF. NO.	PART NO.	DESCRIPTION	REF. NO.	PART NO.	DESCRIPTION	REF. NO.	PART NO.	DESCRIPTION
37	805506	Guard-Flywheel (Black) ———— Note ———— 805504 Guard-Flywheel (Red)	308B	808310	Cover-Cylinder (Used After Code Date 95071400). ———— Note ———— 807870 Cover-Cylinder (Cylinder #1 Black) (Used After Code Date 90111600 and Before Code Date 95071500). 807658 Cover-Cylinder (Cylinder #1 Black) Or 807650 Cover-Cylinder (Cylinder #1 Red)	373	805383	Nut
189	805449	Washer-Lock				423	805260	Screw-Phillips Hex.
305	805406	Screw-Hex.				526	805448	Screw-Phillips Hex.
308	808309	Cover-Cylinder (Used After Code Date 95071400). ———— Note ———— 807868 Cover-Cylinder (Cylinder #1 Black) (Used After Code Date 90111600 and Before Code Date 95071500). 807656 Cover-Cylinder (Cylinder #1 Black) (Used Before Code Date 90111700).	308C	808100	Cover-Cylinder (Used After Code Date 90111600). ———— Note ———— 807659 Cover-Cylinder (Cylinder #2 Black) Or 807651 Cover-Cylinder (Cylinder #2 Red) (Used Before Code Date 90111700).	529	805641	Grommet
308A	807869	Cover-Cylinder (Cylinder #2 Black) (Used After Code Date 90111600). ———— Note ———— 807657 Cover-Cylinder (Cylinder #2 Black) Or 807649 Cover-Cylinder				573	807663	Plate-Back (Black) ———— Note ———— 807655 Plate-Back (Red)
						657	805009	Screw-Phillips
						727	805505	Cover-Starter Drive (Black) ———— Note ———— 805503 Cover-Starter Drive (Red) Used on Type No(s). 0026, 0121.
						865	807661	Cover-Air Guide (Black) ———— Note ———— 807653 Cover-Air Guide (Red)
						866	805738	Cover-Air Guide (Black) ———— Note ———— 807652 Cover-Air Guide (Red)
						879	805841	Cover-Carburetor
						1046	805753	Plug-Blower Housing

★ Included in Gasket Set-See Ref. 358.
● Included in Carburetor Kit-See Ref. 121.

△ Included in Valve Overhaul Kit-See Ref. 1033.

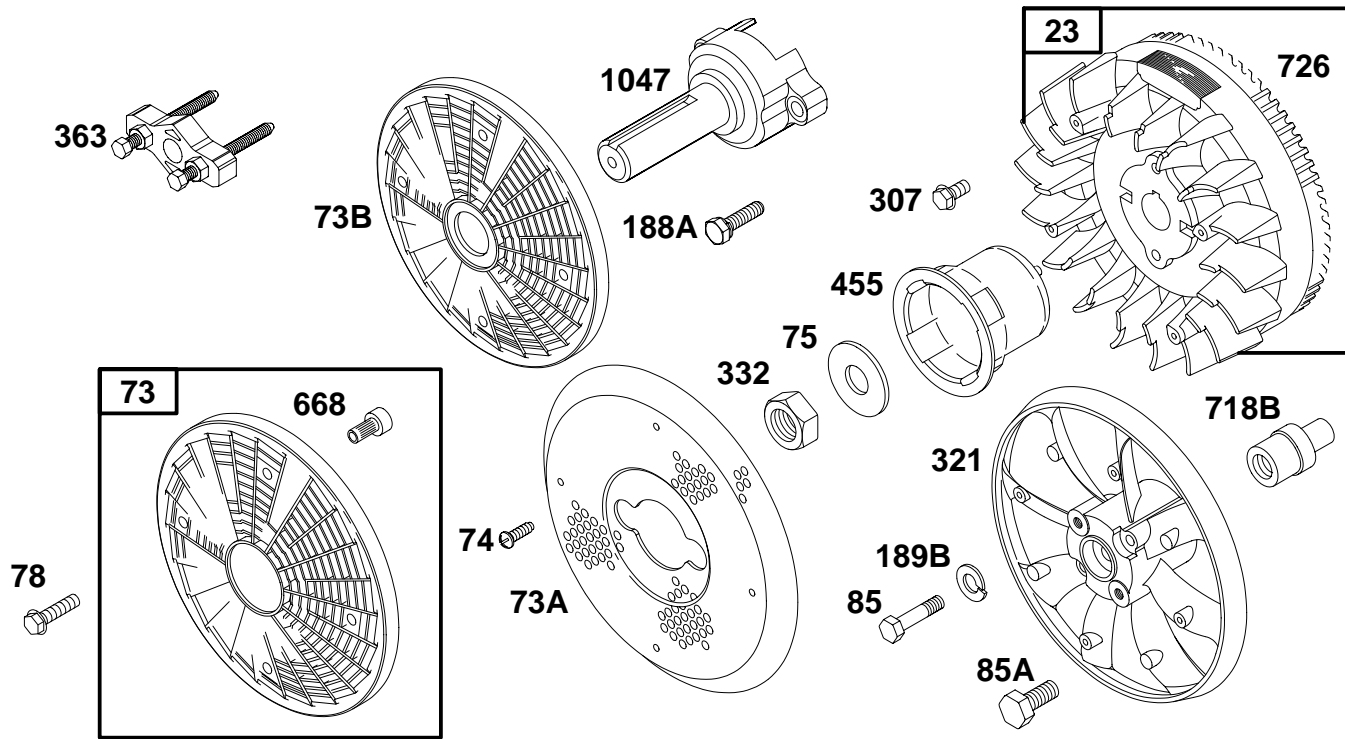

REF. NO.	PART NO.	DESCRIPTION	REF. NO.	PART NO.	DESCRIPTION	REF. NO.	PART NO.	DESCRIPTION
23	807531	Flywheel	73	494439	Screen-Rotating	363	19203	Flywheel Puller
		Note	73A	224779	Screen-Rotating	455	805876	Cup-Flywheel
	807520	Flywheel	73B	805723	Screen-Rotating			Note
		Used on Type No(s).	74	94626	Screw-Phillips			805153 Cup-Flywheel
		0307, 0318, 0320,	75	805007	Washer-Spring			(Used Before Code
		0340, 0347, 0350,	78	805447	Screw-Hex.			Date 93072600).
		0353, 0357, 0359,	85	94385	Screw-Hex.	668	805402	Spacer
		0360, 0361, 0363,	85A	94493	Screw-Hex.	718B	805613	Pin-Locating
		0366, 0370, 0372,	188A	93847	Screw-Hex.	726	807805	Gear-Ring
		0385, 0390, 0391,	189B	90366	Washer-Lock	1047	807867	Shaft-Stub
		0398, 0402, 0408,	307	805025	Screw-Hex.			
		0409, 0412, 0415,	321	213472	Fan-Booster			
		0416, 0422, 0426,	332	805021	Nut-Flywheel			
		0427, 0433, 0443,						
		0445, 0446, 0447,						
		0448, 0454, 0457,						
		0458, 0459, 0500,						
		0503, 0505, 1066,						
		1072, 1133, 1136,						
		1146, 1147, 1148,						
		1157, 1159, 1191,						
		1205, 1206.						
	807530	Flywheel						
		Used on Type No(s).						
		0124, 0407, 0410,						
		0414, 0421, 0429,						
		0430, 0503, 1114,						
		1163.						

★ Included in Gasket Set-See Ref. 358.
 ● Included in Carburetor Kit-See Ref. 121.

△ Included in Valve Overhaul Kit-See Ref. 1033.

290400 to 290499

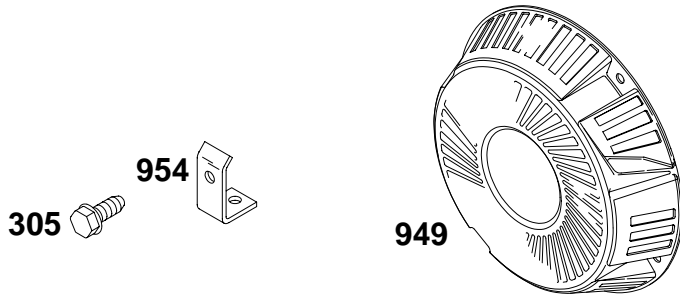
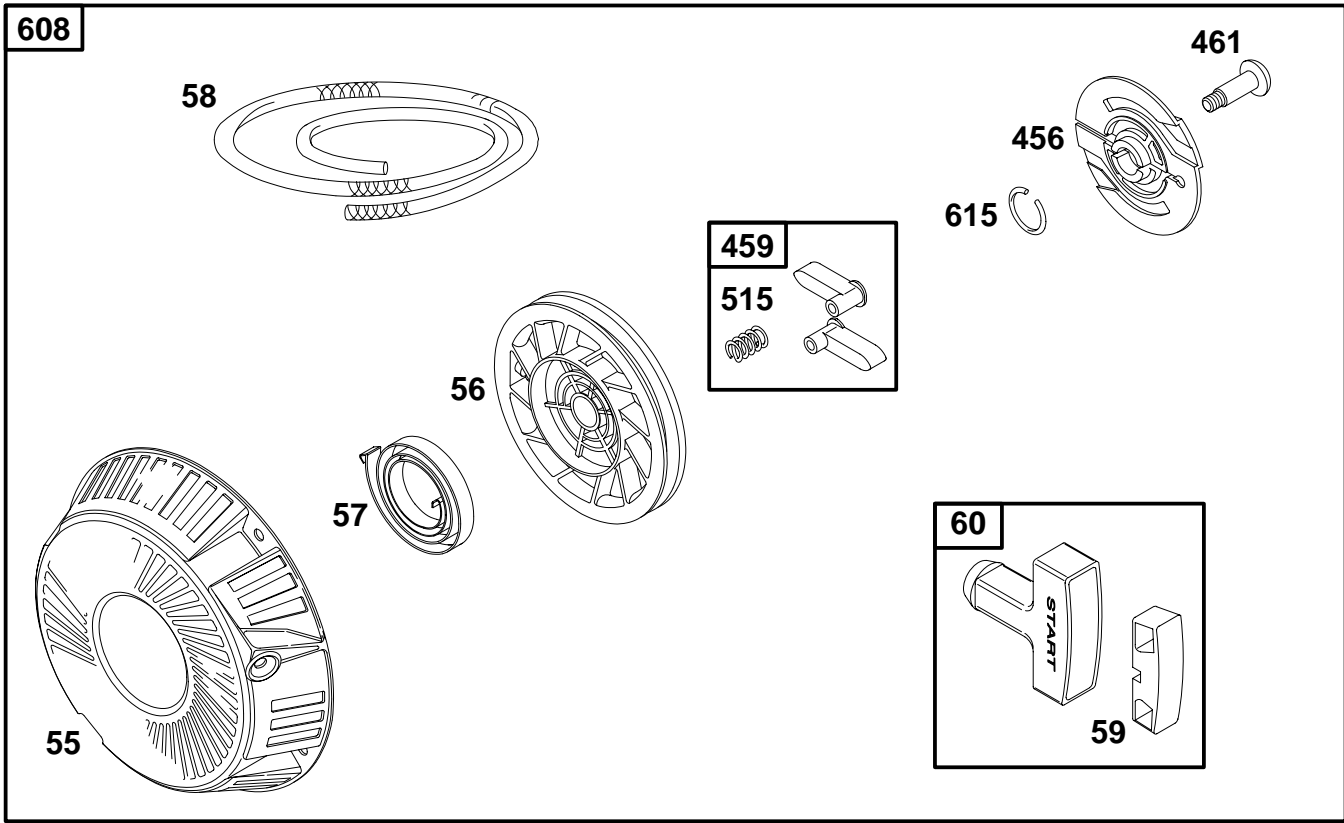

REF. NO.	PART NO.	DESCRIPTION	REF. NO.	PART NO.	DESCRIPTION	REF. NO.	PART NO.	DESCRIPTION
55	808186	Housing-Rewind Starter	60	808167	Grip-Starter Rope	615	805952	Retainer
56	805949	Pulley-Starter	305	805406	Screw-Hex.	949	808086	Guard-Finger Used on Type No(s). 0431, 0504, 1149, 1154.
57	805951	Spring-Rewind Starter	456	805954	Plate-Retainer	954	805430	Bracket-Mounting
58	66574	Rope-Starter (Cut to Required Length)	459	808166	Pawl-Ratchet			
59	805957	Insert-Grip	461	805955	Screw-Shoulder			
			515	805953	Spring-Pawl			
			608	808087	Starter-Rewind			

★ Included in Gasket Set-See Ref. 358.
● Included in Carburetor Kit-See Ref. 121.

△ Included in Valve Overhaul Kit-See Ref. 1033.

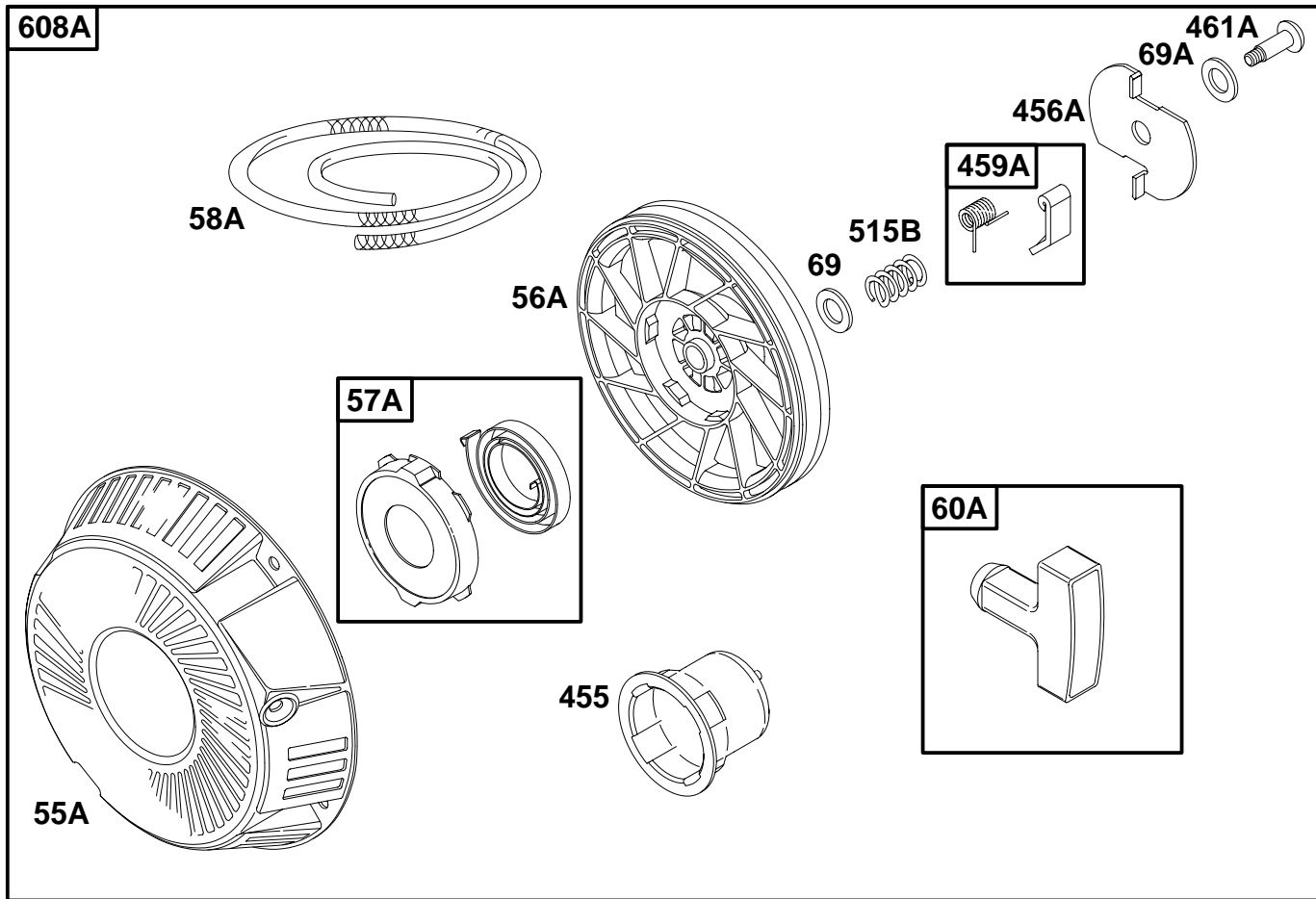

305

REF. NO.	PART NO.	DESCRIPTION	REF. NO.	PART NO.	DESCRIPTION	REF. NO.	PART NO.	DESCRIPTION
55A	492193	Housing-Rewind Starter	60A	490652	Grip-Starter Rope	459A	492431	Spring-Pawl
56A	280918	Pulley-Starter	69	94464	Washer	461A	94463	Screw-Shoulder
57A	492194	Spring-Rewind Starter	69A	94462	Washer	515B	262564	Spring-Friction
58A	66894	Rope-Starter (Cut to Required Length)	305	805406	Screw-Hex.	608A	808152	Starter-Rewind (Used Before Code Date 93072600).
			455	805876	Cup-Flywheel			
			456A	224228	Retainer-Spring			

★ Included in Gasket Set-See Ref. 358.
● Included in Carburetor Kit-See Ref. 121.

△ Included in Valve Overhaul Kit-See Ref. 1033.

290400 to 290499

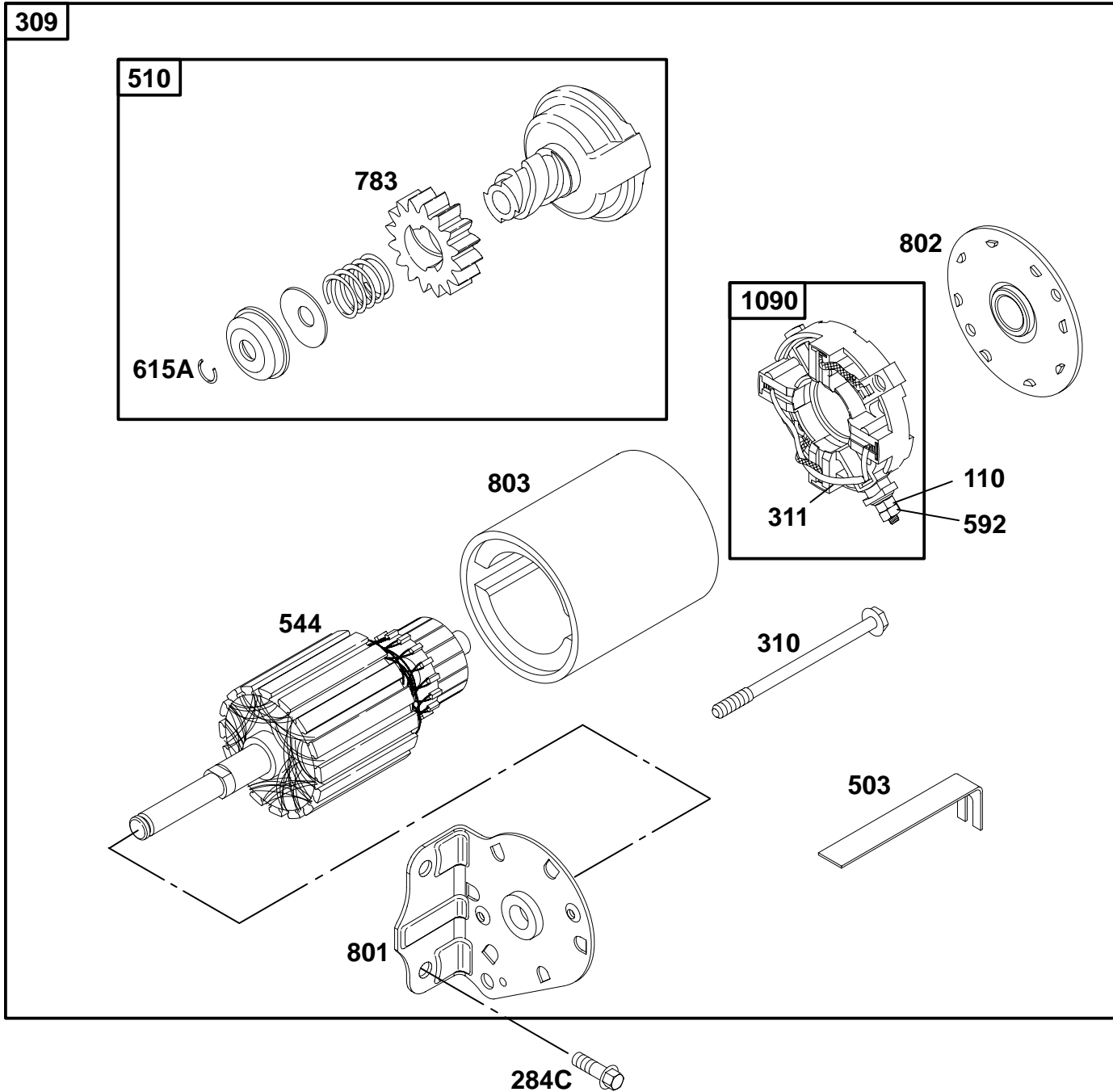

REF. NO.	PART NO.	DESCRIPTION	REF. NO.	PART NO.	DESCRIPTION	REF. NO.	PART NO.	DESCRIPTION
110	225137	Washer	544★		Armature-Starter (Served By 499521 Starter Motor Only)	801	497626	Cap-Drive
284C	805247	Screw-Hex.				802	497607	Cap-End
309	499521	Motor-Starter				803★		Housing-Starter (Served By 499521 Starter Motor Only)
310	95035	Screw-Hex.	592	92278	Nut-Hex.			
311	497608	Brush Set	615A	263080	Retainer	1090	497605	Retainer-Brush
503	806000	Strap-Starter	783	280104	Gear-Starter			
510	497606	Drive-Starter						

★ Included in Gasket Set-See Ref. 358.
● Included in Carburetor Kit-See Ref. 121.

△ Included in Valve Overhaul Kit-See Ref. 1033.

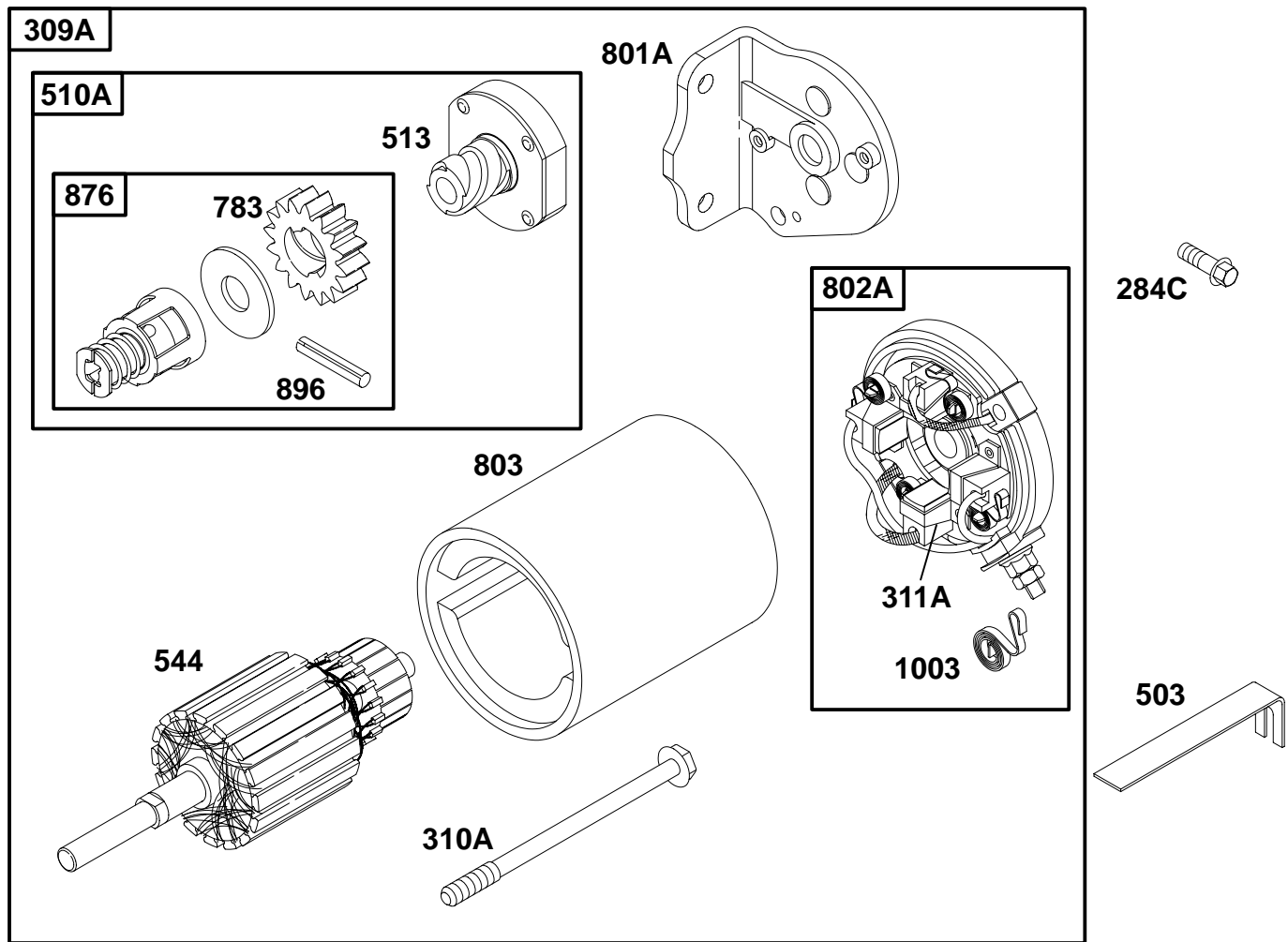

REF. NO.	PART NO.	DESCRIPTION	REF. NO.	PART NO.	DESCRIPTION	REF. NO.	PART NO.	DESCRIPTION
284C	805247	Screw-Hex.	513	398003	Clutch-Drive	803	398892	Housing-Starter (For 4 9/16" Housing Length)
309A	494990	Motor-Starter (4 3/8" Housing Length)	544	490309	Armature-Starter	Note _____ 494205 Housing-Starter (For 4 3/8" Housing Length)		
310A	94004	Screw-Hex. (For 4 3/8" Housing Length)	783	280104	Gear-Starter			
311A	490311	Brush Set	801A	394856	Cap-Drive	876	495877	Kit-Gear
503	806000	Strap-Starter (For 4 9/16" Housing Length)	802A	490310	Cap-End (For 4 9/16" Housing Length)	896	94288	Pin-Roll
510A	495878	Drive-Starter (For 4 3/8" Housing Length)	Note _____ 494988 Cap-End (For 4 3/8" Housing Length)		1003	490316	Spring-Brush	

★ Included in Gasket Set-See Ref. 358.
 ● Included in Carburetor Kit-See Ref. 121.

△ Included in Valve Overhaul Kit-See Ref. 1033.

290400 to 290499

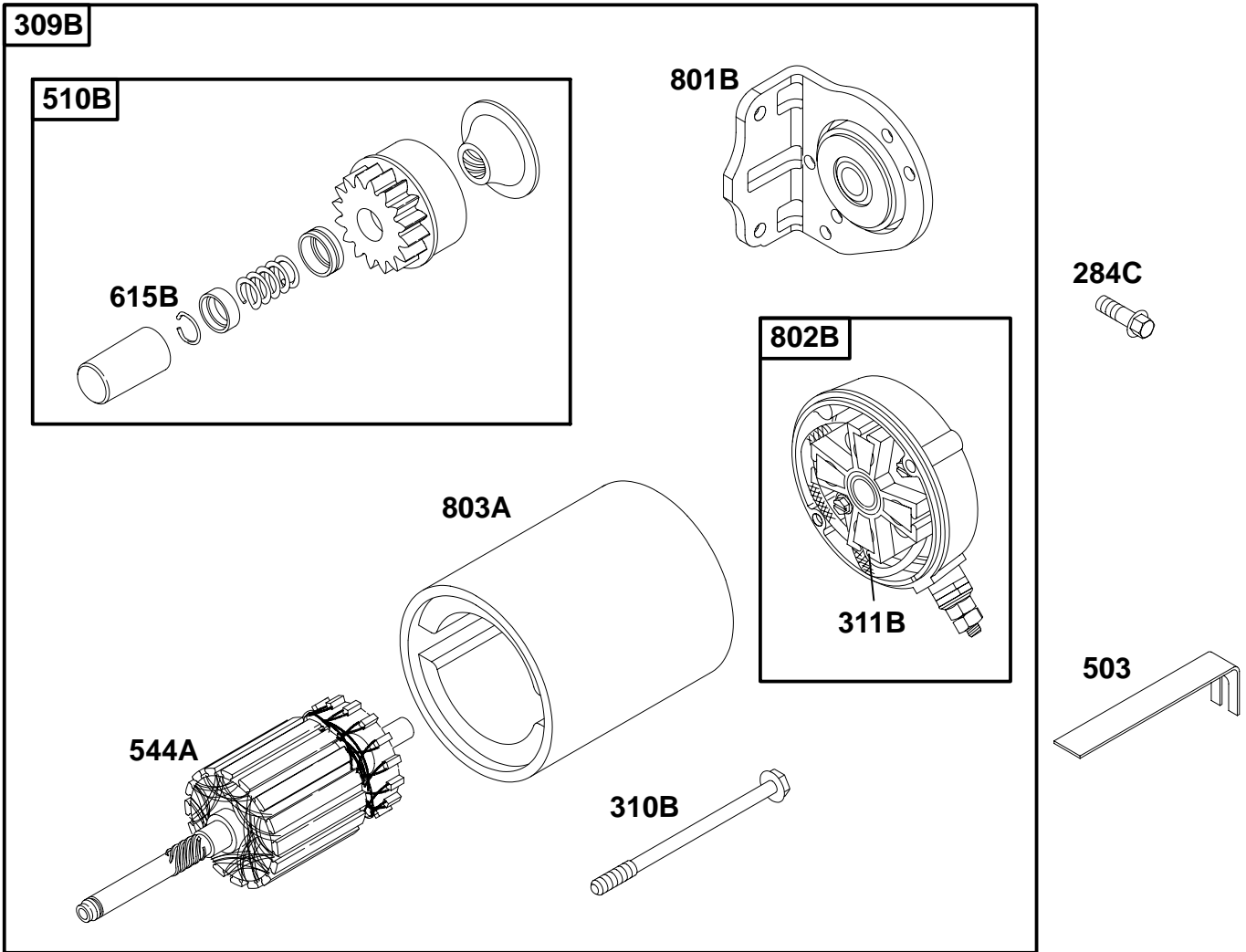

REF. NO.	PART NO.	DESCRIPTION	REF. NO.	PART NO.	DESCRIPTION	REF. NO.	PART NO.	DESCRIPTION
284C	805247	Screw-Hex.	311B	496887	Brush Set	615B	94953	Retainer
309B	808106	Motor-Starter	503	806000	Strap-Starter	801B	496814	Cap-Drive
		(Steel Pinion)	510B	496881	Drive-Starter	802B	496813	Cap-End
310B	496880	Screw-Hex.	544A	496816	Armature-Starter	803A	496815	Housing-Starter

★ Included in Gasket Set-See Ref. 358.
 ● Included in Carburetor Kit-See Ref. 121.

△ Included in Valve Overhaul Kit-See Ref. 1033.

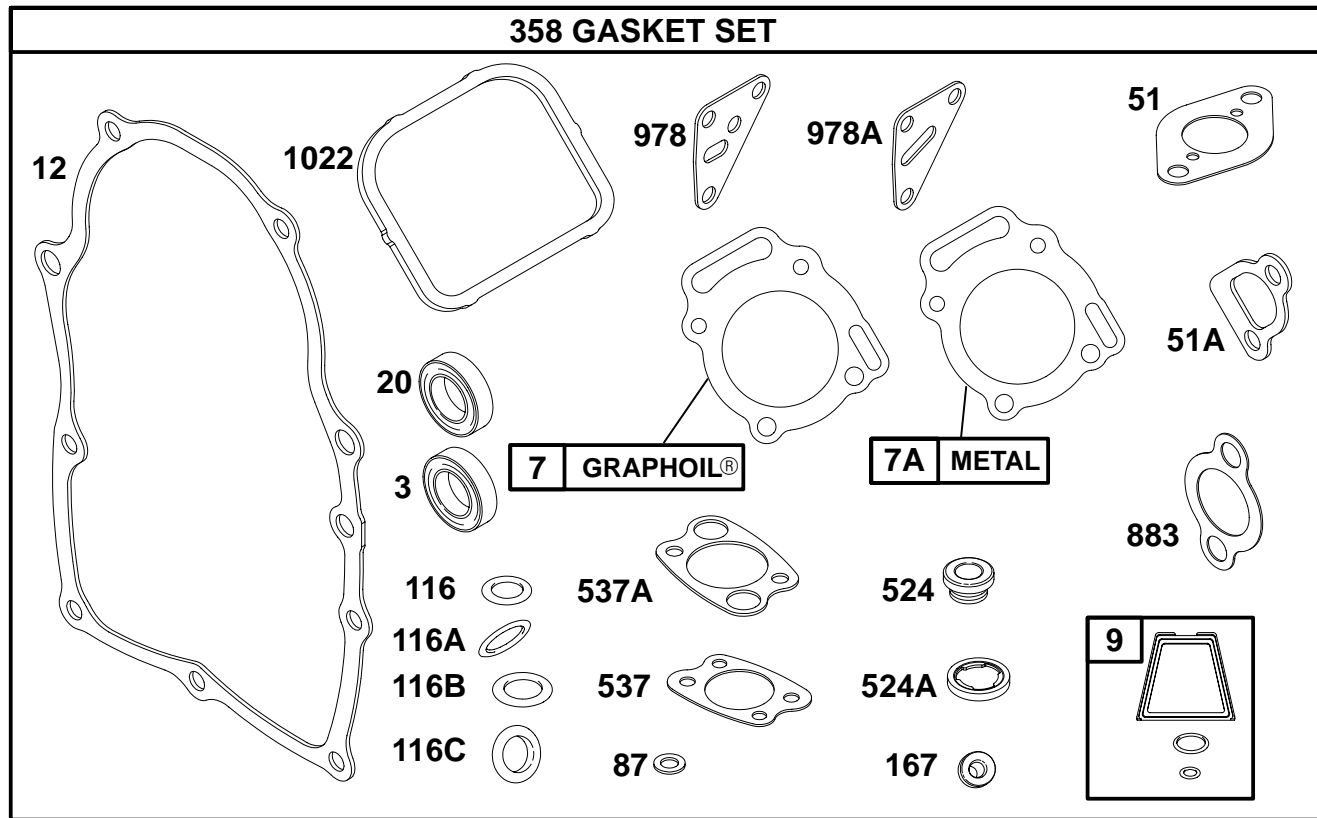

REF. NO.	PART NO.	DESCRIPTION	REF. NO.	PART NO.	DESCRIPTION	REF. NO.	PART NO.	DESCRIPTION
3	★805101	Seal-Oil	116A	★805386	Seal-O-Ring	537	★805655	Gasket-Air Cleaner
7	★Δ806085	Gasket-Cylinder Head	116B	★805058	Seal-O-Ring (Oil Pump)	537A	★805003	Gasket-Air Cleaner
7A	★Δ807986	Gasket-Cylinder Head (Used Before Code Date 96040100).	116C	★805316	Seal-O-Ring (Pick-Up Tube)	883	★Δ805024	Gasket-Exhaust
9	★807688	Gasket-Breather	167	★Δ805420	Washer	978	★805250	Gasket
12	★805112	Gasket-Crankcase	358	808390	Gasket Set	978A	★805229	Gasket
20	★805049	Seal-Oil			Note	1022	★Δ806039	Gasket-Rocker Cover
51	★805700	Gasket-Intake			807989 Gasket Set (Used Before Code Date 96040100).			
51A	★Δ805023	Gasket-Intake	524	★281370	Seal-Fill Tube			
87	★805054	Seal-Governor Shaft	524A	★Δ271983	Seal-Fill Tube			
116	★805198	Seal-O-Ring (Crankcase Cover)						

★ Included in Gasket Set-See Ref. 358.
● Included in Carburetor Kit-See Ref. 121.

Δ Included in Valve Overhaul Kit-See Ref. 1033.

290400 to 290499

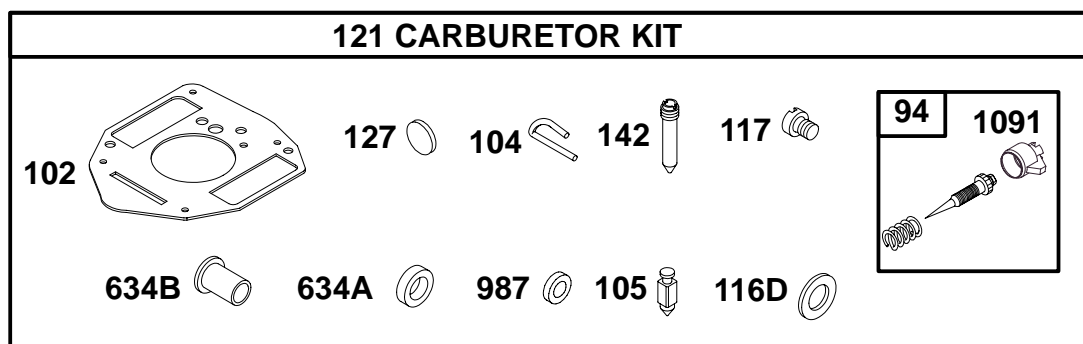
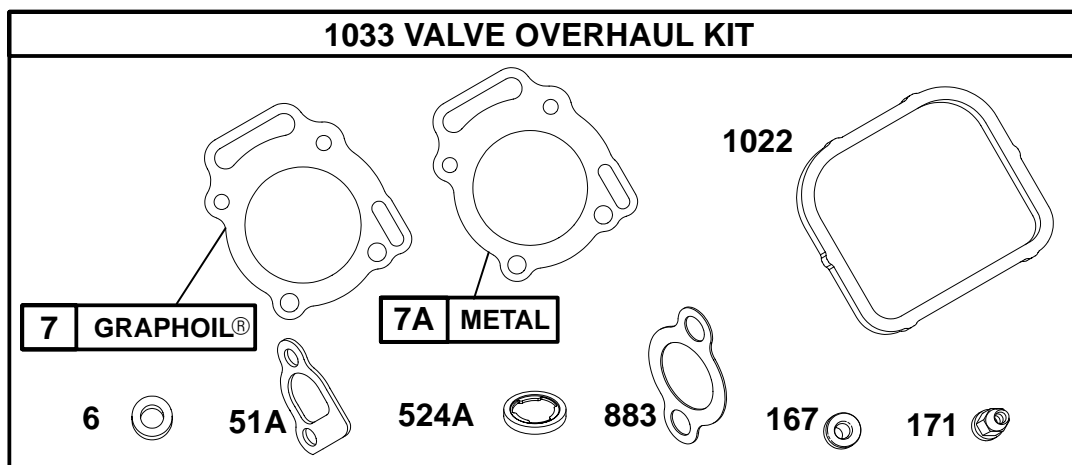

REF. NO.	PART NO.	DESCRIPTION	REF. NO.	PART NO.	DESCRIPTION	REF. NO.	PART NO.	DESCRIPTION	
6	Δ805193	Washer—Flat (Used Before Code Date 94050100).	105	●805547	Valve—Needle (Pump Feed Carburetors)	121	807850	Carburetor Kit	
7	★Δ806085	Gasket—Cylinder Head			———— Note ————			———— Note ————	
7A	★Δ807986	Gasket—Cylinder Head (Used Before Code Date 96040100).			●805620	Valve—Needle (Gravity Feed Carburetors)		808262	Carburetor Kit Used on Type No(s). 0478, 1155, 1178.
51A	★Δ805023	Gasket—Intake	116D	●805549	Washer—Seal	127	●805559	Plug—Welch	
94	●808257	Valve—Idle Adjustment	117	●805852	Jet—Main (Standard)	142	●805553	Nozzle—Carburetor	
		———— Note ————			(Used After Code Date 94123100).	167	★Δ805420	Washer	
		●807719			———— Note ————	171	Δ805019	Nut—Lock	
		Valve—Idle Adjustment (Used Before Code Date 95010100).			●805624	Jet—Main (Standard)	524A	★Δ271983	Seal—Fill Tube
102	●805541	Gasket—Carburetor Body			(Used Before Code Date 95010100).	634A	●805557	Collar—Throttle	
104	●805545	Pin—Float Hinge			●805625	Jet—Main (High Altitude) (Used After Code Date 89111700).	634B	●805543	Collar—Choke Shaft
							883	★Δ805024	Gasket—Exhaust
							987	●805544	Seal—Shaft
							1022	★Δ806039	Gasket—Rocker Cover
							1033	808392	Kit—Valve Overhaul
								———— Note ————	
								807990	Kit—Valve Overhaul (Used Before Code Date 96040100).
							1091	●805862	Cap—Limiter

★ Included in Gasket Set—See Ref. 358.
● Included in Carburetor Kit—See Ref. 121.

Δ Included in Valve Overhaul Kit—See Ref. 1033.