

Illustrated Parts List

Model Series

285700 to 285799

TYPE NUMBERS
0101, 0113, 0114,
0143, 0604, 0613.

TO FIND
THE CORRECT NUMBER OF THE PART YOU NEED:
FOLLOW THE INSTRUCTIONS BELOW

- A. Refer to Engine Model, Type and Code Number that is stamped on the blower housing of engine. Engine type numbers such as 0123 01 are listed only as 0123 in most instances. The two digits (01 or 02, etc.) to the right of the space may be required for more accurate parts identification in some instances. Select the Illustrated Parts List covering the correct Model Series and Type Number.
- B. Refer to the Illustrations and compare the original part with Illustration. The number next to the illustration is the Reference Number. Assemblies include all parts shown in frames. All parts shown in assembly frames having individual reference numbers can be purchased separately.
- C. After the Reference Number has been identified, refer to the Numerical text, where Reference and Primary Part Number are listed. **THE PRIMARY PART IS USED ON ALL TYPE NUMBERS EXCEPT THOSE TYPE NUMBERS UNDER "NOTE."**
- D. If a "Note" appears below the Primary Part Number, it means that this part differs from the Primary Part for certain types. If your Type number is listed under "Note," order the part referred to at the "Note."
- E. If your Engine Type Number does not appear after any part number listed under "Note," use the Primary Part Number.
- F. For Engine Type Numbers not covered by this book, check other Parts Lists having the same engine model or contact your source of supply.

PRINTED IN U.S.A.



COPYRIGHT by BRIGGS & STRATTON CORPORATION
All rights reserved. No part of this material may be reproduced or transmitted, in any form or by any means, electronic or mechanical, including photocopying, recording or by any information storage and retrieval system, without permission in writing from Briggs & Stratton Corporation.

285700 to 285799

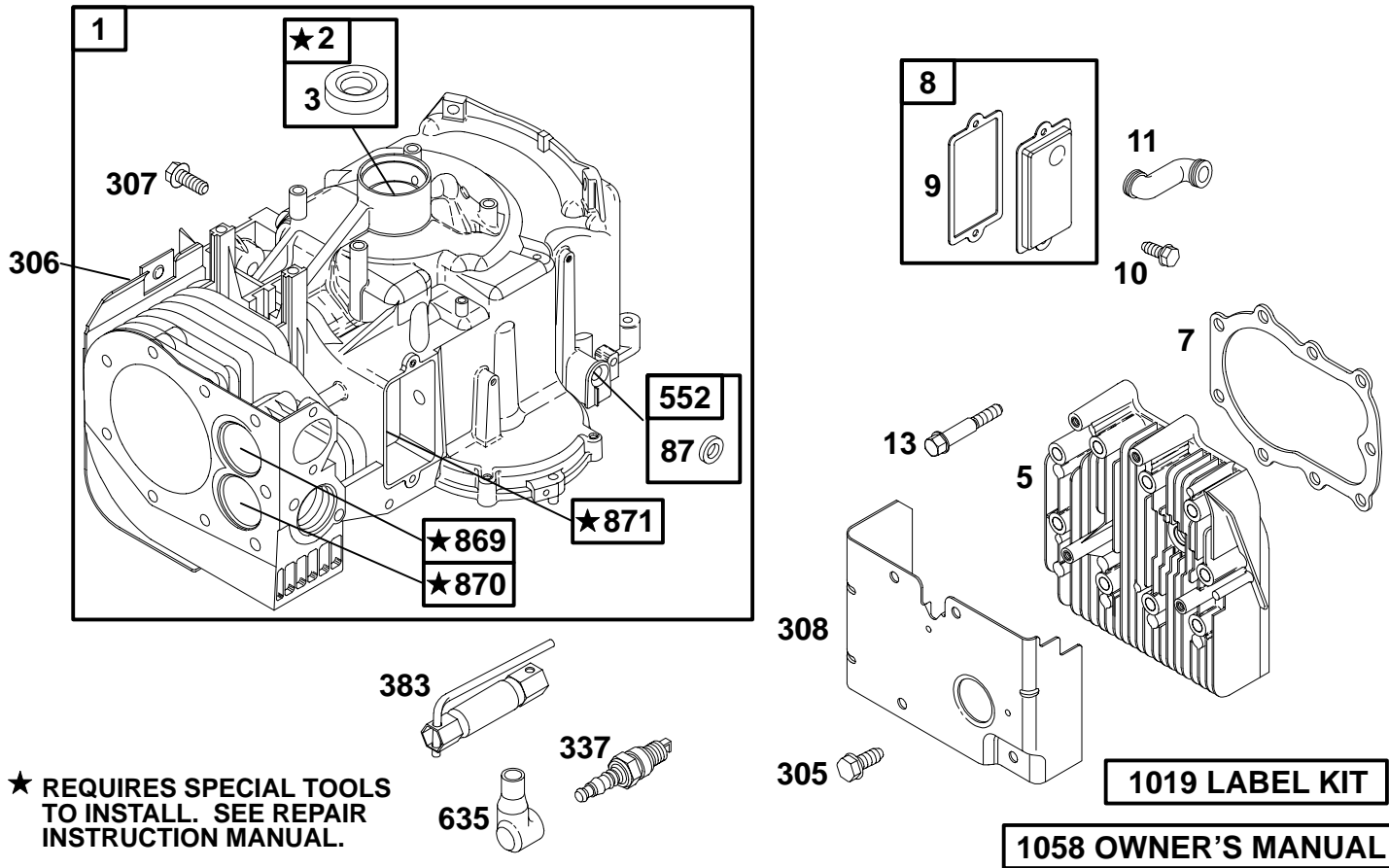

★ REQUIRES SPECIAL TOOLS TO INSTALL. SEE REPAIR INSTRUCTION MANUAL.

1019 LABEL KIT

1058 OWNER'S MANUAL

REF. NO.	PART NO.	DESCRIPTION	REF. NO.	PART NO.	DESCRIPTION	REF. NO.	PART NO.	DESCRIPTION
1	496414	Cylinder Assembly	306	224545	Shield-Cylinder	871	261961	Bushing-Guide (Exhaust Valve)
2	399265	Bushing	307	94386	Screw-Hex.	———— Note ————		
3	★391086	Seal-Oil	308	491490	Cover-Cylinder	231218		Bushing-Guide (Intake Valve) (Brass)
5	494240	Head-Cylinder	337	802592	Plug-Spark	1019	491252	Label Kit
7	★∅271866	Gasket-Cylinder Head	383	89838	Wrench-Spark Plug	1058	272697	Owner's Manual
8	495735	Breather Assembly	552	491986	Bushing-Governor Crank	———— Note ————		
9	★∅27803	Gasket-Breather	635	66538	Boot-Spark Plug	273131		Owner's Manual
10	94621	Screw-Hex.	869	261463	Seat-Valve (Intake)	Used on Type No(s). 0604, 0613.		
11	280100	Tube-Breather	870	262924	Seat-Valve (Exhaust)			
13	94622	Screw-Hex.						
87	★491323	Seal-Governor Shaft						
305	94786	Screw-Hex.						

★ Included in Gasket Set-Part Number 494241.
● Included in Carburetor Kit-See Ref. 121.

◆ Included in Carburetor Gasket Set-Part No. 494385.
∅ Included in Valve Overhaul Gasket Set-Part No. 498539.

285700 to 285799

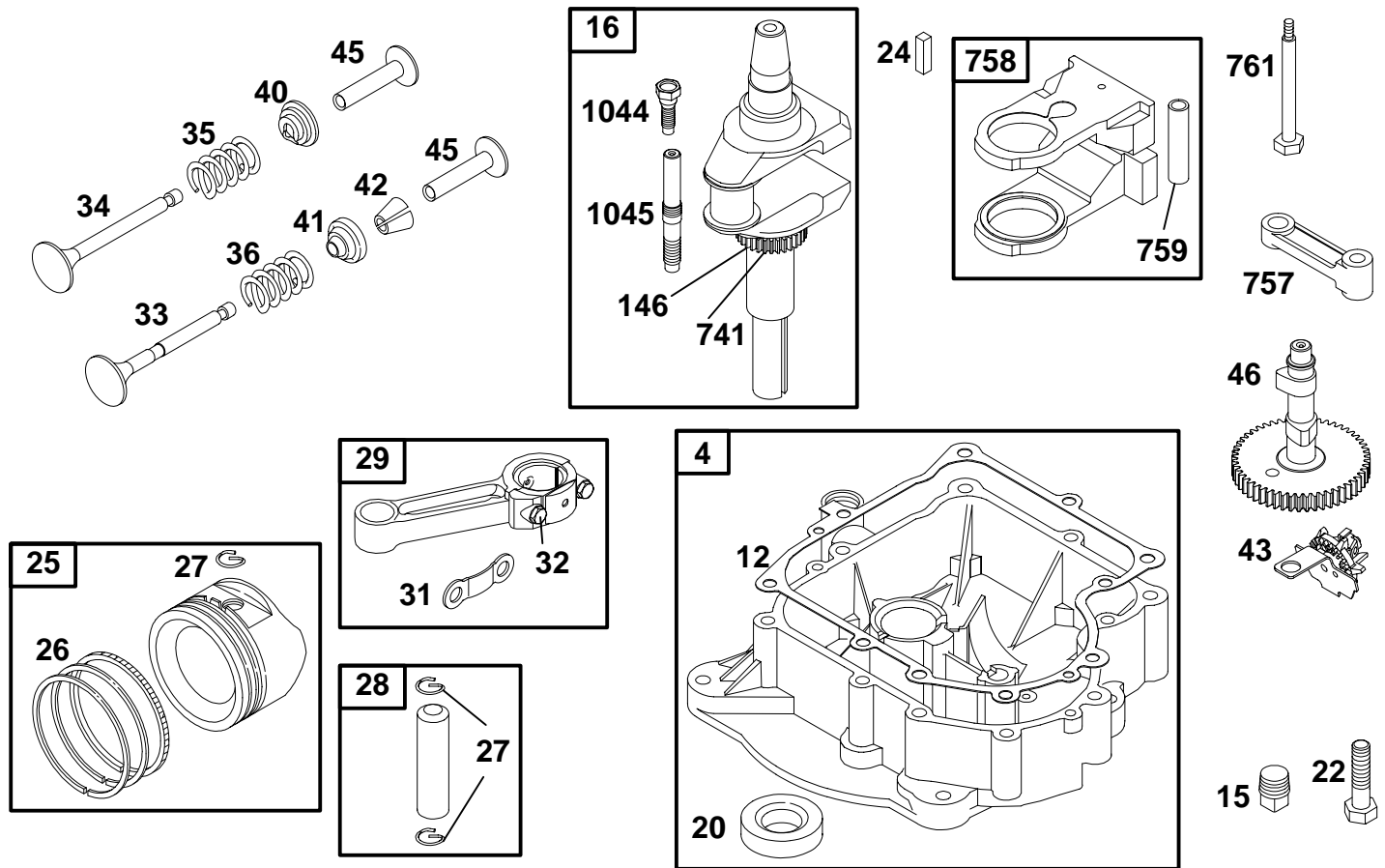

REF. NO.	PART NO.	DESCRIPTION	REF. NO.	PART NO.	DESCRIPTION	REF. NO.	PART NO.	DESCRIPTION			
4	494238	Sump-Engine	26	391780	Ring Set (Standard)	31	222299	Lock-Rod Screw			
12	★271916	Gasket-Crankcase (.015" Thick)			Note	32	94671	Screw-Connecting Rod			
		Note			392331			33	262246	Valve-Exhaust	
		★271997			(Chrome Standard)	34	262247	Valve-Intake	35	65906	Spring-Valve
		Gasket-Crankcase (.005" Thick)			391781			36	26828	Spring-Valve	
		★271996			(.010" O.S.)	391782		40	221596	Retainer-Valve	
		Gasket-Crankcase (.009" Thick)			(.020" O.S.)	391783		41	292260	Retainer-Valve	
15	94239	Plug-Oil Drain			(.030" O.S.)	42	494553	Keeper-Valve	43	490815	Governor/Oil Slinger
16	495162	Crankshaft	27	260924	Lock-Piston Pin	43	490815	Governor/Oil Slinger	44	262248	Tappet-Valve
20	★291675	Seal-Oil	28	299691	Pin-Piston (Standard)	45	262248	Tappet-Valve	46	212897	Gear-Cam
22	94624	Screw-Hex.			Note	146	94196	Key-Timing	741	262932	Gear-Timing
24	222698	Key-Flywheel			391286			757	213998	Link-Counterweight	
25	391285	Piston Assembly (Standard)			(.050" O.S.)	758	399891	Counterweight	759	230787	Pin-Counterweight
		Note	29	490348	Rod-Connecting (Standard)	759	230787	Pin-Counterweight	761	94593	Screw-Hex.
		391287			(Standard)	1044	94673	Screw-Shoulder	1045	231828	Adapter-Crankshaft
		(.010" O.S.)			Note	1045	231828	Adapter-Crankshaft			
		391288			490469						
		(.020" O.S.)			(.020" Undersize)						
		391289									
		(.030" O.S.)									

★ Included in Gasket Set-Part Number 494241.
● Included in Carburetor Kit-See Ref. 121.

◆ Included in Carburetor Gasket Set-Part No. 494385.
◊ Included in Valve Overhaul Gasket Set-Part No. 498539.

285700 to 285799

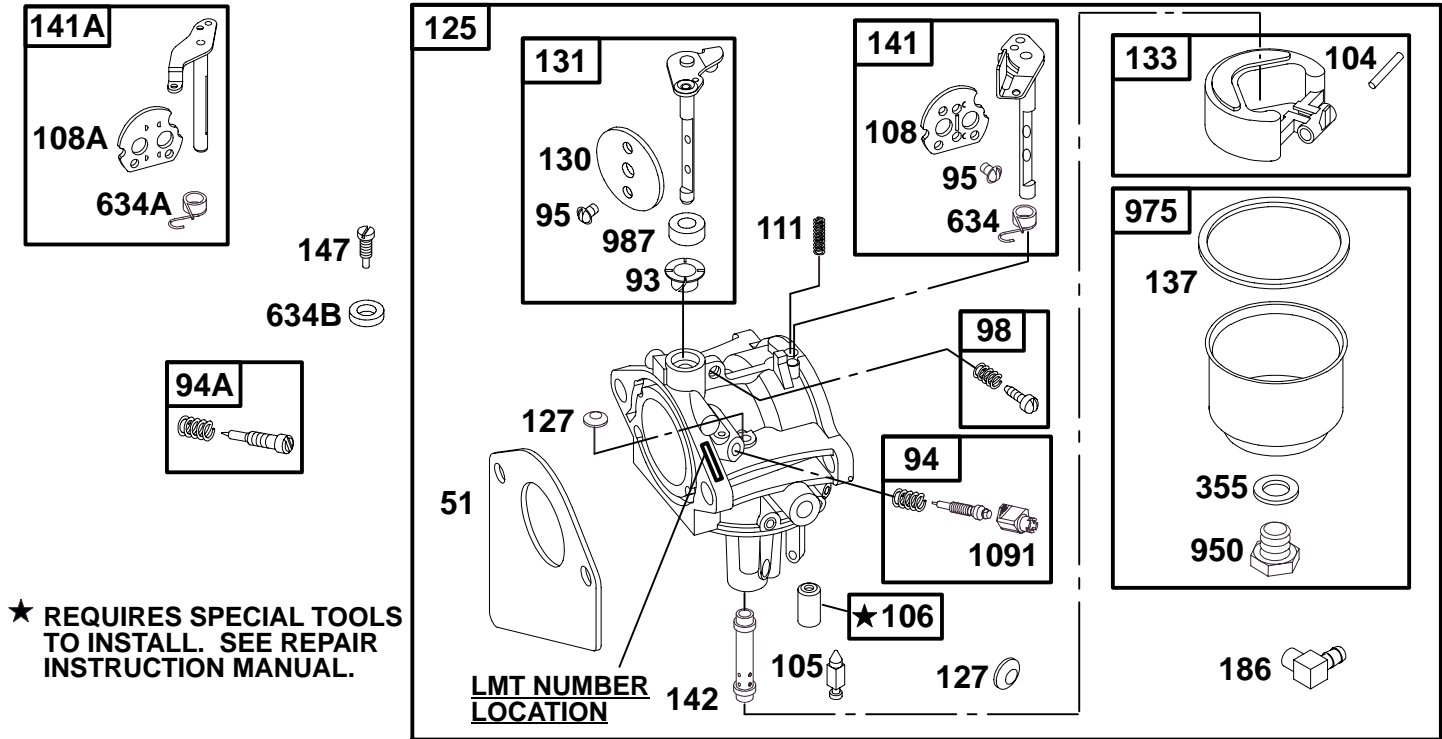

THIS CARBURETOR SERVICES BOTH CHOKE-A-MATIC AND MANUAL CHOKE SYSTEMS

REF. NO.	PART NO.	DESCRIPTION	REF. NO.	PART NO.	DESCRIPTION	REF. NO.	PART NO.	DESCRIPTION
51	◆272465	Gasket-Intake	125	498027	Carburetor (For Choke A Matic and Manual Choke)	142	◆497736	Nozzle-Carburetor (Standard) (LMT 92,96)
93	●281346	Bushing-Throttle Shaft			Note			Note
94	498030	Valve-Idle Adjustment			495706 Carburetor (For Choke A Matic and Manual Choke) (Used Before Code Date 96072600).		◆497566	Nozzle-Carb. (Standard) (LMT 37,41,81,157)
94A	495932	Valve-Idle Adjustment	127	●	Plug-Welch (Sold in Kit Only)		497737	Nozzle-Carb. (High Altitude) (LMT 92,96)
95	●94098	Screw-Choke/Throttle	130	224539	Valve-Throttle		497567	Nozzle-Carb. (High Altitude) (LMT 37,41,81,157)
98	495800	Screw-Idle Speed	131	494379	Shaft-Throttle	147	497472	Jet-Pilot (LMT 37,41,81)
104	●231789	Pin-Float Hinge	133	494381	Float-Carburetor	186	493496	Connector-Hose
105	●231855	Valve-Needle (Used After Code Date 92071900).	137	◆281165	Gasket-Float Bowl	355	◆281164	Washer-Seal
		Note	141	495097	Choke Shaft Kit (Manual Choke)	634	●494453	Seal-Spring Assembly (Manual Choke)
106	●231854	Seat-Inlet (Used After Code Date 92071900).	141A	495931	Choke Shaft Kit (Choke A Matic)	634A	●494455	Seal-Spring Assembly (Choke A Matic)
		Note			Note	634B	281167	Seal (Throttle Shaft) (LMT 37)
		494788 Valve- Needle (Used Before Code Date 92072000).			494380 Shaft-Choke (Choke A Matic) (Used Before Code Date 92091500).	950	94642	Screw-Bowl Mounting
108	224558	Valve-Choke (Manual Choke)				975	495933	Bowl-Float
108A	224540	Valve-Choke (Choke A Matic)				987	●281166	Seal-Throttle Shaft
111	262820	Spring-Friction				1091	281364	Cap-Limiter

★ Included in Gasket Set-Part Number 494241.
● Included in Carburetor Kit-See Ref. 121.

◆ Included in Carburetor Gasket Set-Part No. 494385.
⊗ Included in Valve Overhaul Gasket Set-Part No. 498539.

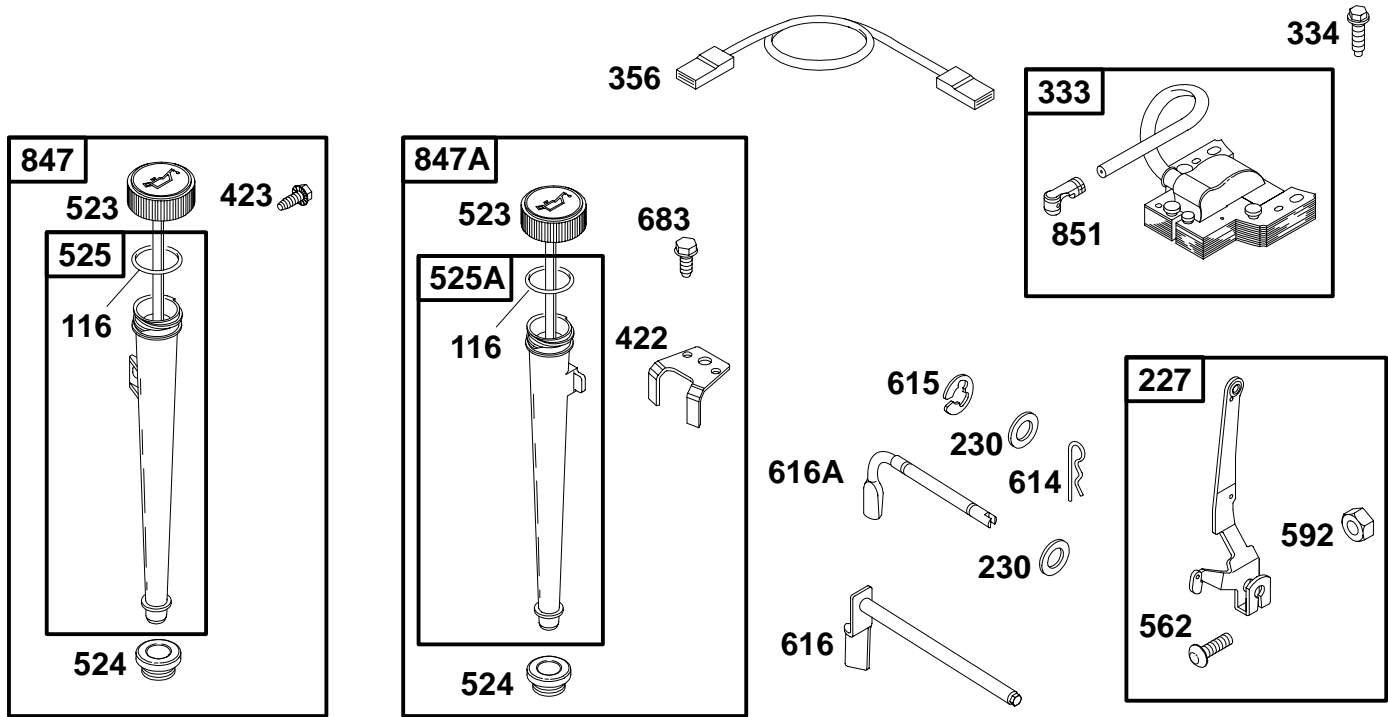

REF. NO.	PART NO.	DESCRIPTION	REF. NO.	PART NO.	DESCRIPTION	REF. NO.	PART NO.	DESCRIPTION
116	★270920	Seal-O-Ring	523	495230	Dipstick	616	495157	Crank-Governor
227	493935	Lever-Governor	524	★281370	Seal-Fill Tube	616A	231058	Crank-Governor
230	94742	Washer	525	496113	Tube-Oil Fill	683	94602	Screw-Hex.
333	492341	Armature-Magneto	525A	495768	Tube-Oil Fill	847	496415	Dipstick/Tube Assembly
334	94731	Screw-Hex.	562	92613	Bolt-Governor Lever	847A	490474	Dipstick/Tube Assembly
356	494328	Wire-Stop	592	231082	Nut-Hex.	851	493880	Terminal-Cable
422	224390	Bracket-Oil Fill	614	93306	Pin-Cotter			
423	94073	Screw-Shoulder	615	93307	Retainer			

★ Included in Gasket Set-Part Number 494241.
 ● Included in Carburetor Kit-See Ref. 121.

◆ Included in Carburetor Gasket Set-Part No. 494385.
 ◊ Included in Valve Overhaul Gasket Set-Part No. 498539.

285700 to 285799

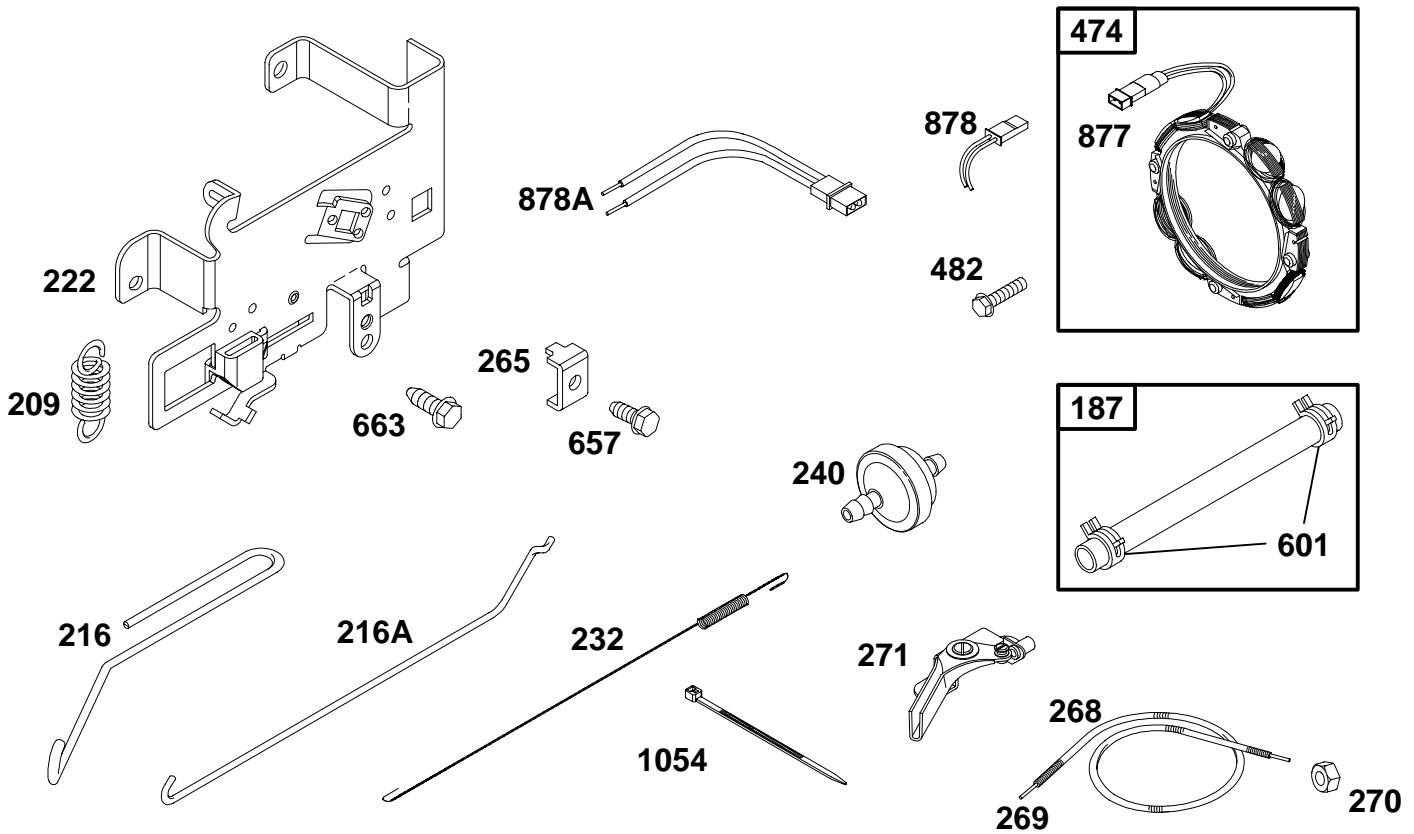

REF. NO.	PART NO.	DESCRIPTION	REF. NO.	PART NO.	DESCRIPTION	REF. NO.	PART NO.	DESCRIPTION
187	299146	Line-Fuel (Cut to Required Length)	240	298090	Filter-Fuel Note	270	63426	Locknut-Casing
209	260871	Spring-Governor Note		394358	Filter-Fuel Used on Type No(s). 0143.	271	290568	Lever-Control
	261306	Spring-Governor Used on Type No(s). 0113, 0613.	265	221535	Clamp-Casing	474	393474	Alternator
216	262766	Link-Choke	268	65616	Casing-Wire (72" Long) (Cut to Required Length)	482	93621	Screw-Hex.
216A	262767	Link-Choke	269	26633	Wire-Control (78" Long) (Cut to Required Length)	601	93053	Clamp-Hose
222	495611	Bracket-Control				657	93496	Screw-Slotted Hex.
232	262785	Spring-Link				663	94620	Screw-Hex.
						877	393456	Wire-Alternator
						878	393362	Harness-Alternator
						878A	399916	Harness-Alternator
						1054	280275	Tie-Cable

★ Included in Gasket Set-Part Number 494241.
● Included in Carburetor Kit-See Ref. 121.

◆ Included in Carburetor Gasket Set-Part No. 494385.
⊗ Included in Valve Overhaul Gasket Set-Part No. 498539.

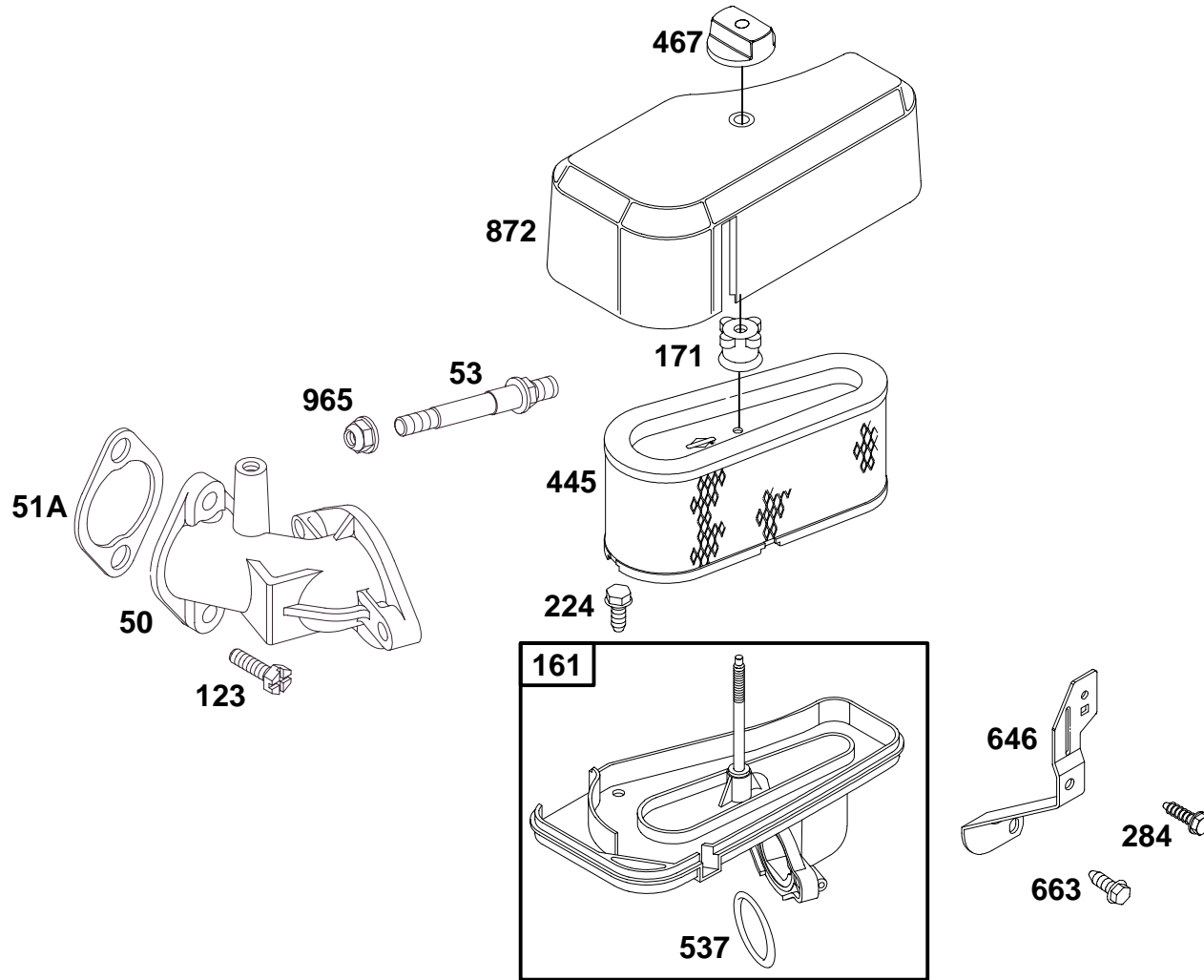

REF. NO.	PART NO.	DESCRIPTION	REF. NO.	PART NO.	DESCRIPTION	REF. NO.	PART NO.	DESCRIPTION
50	213819	Manifold-Intake	171	281051	Nut	537	★∅281106	Gasket-Air Cleaner
51A	★∅272554	Gasket-Intake	224	94513	Screw-Hex.	646	224546	Brace
53	94637	Stud-Carburetor Mounting	284	94704	Screw-Hex.	663	94620	Screw-Hex.
123	94616	Screw-Torx®Hex.	445	496894	Filter-Air	872	281104	Cover-Air Cleaner
161	494237	Base-Air Cleaner	467	493903	Nut-Air Cleaner	965	94010	Nut-Hex.

★ Included in Gasket Set-Part Number 494241.
 ● Included in Carburetor Kit-See Ref. 121.

◆ Included in Carburetor Gasket Set-Part No. 494385.
 ∅ Included in Valve Overhaul Gasket Set-Part No. 498539.

285700 to 285799

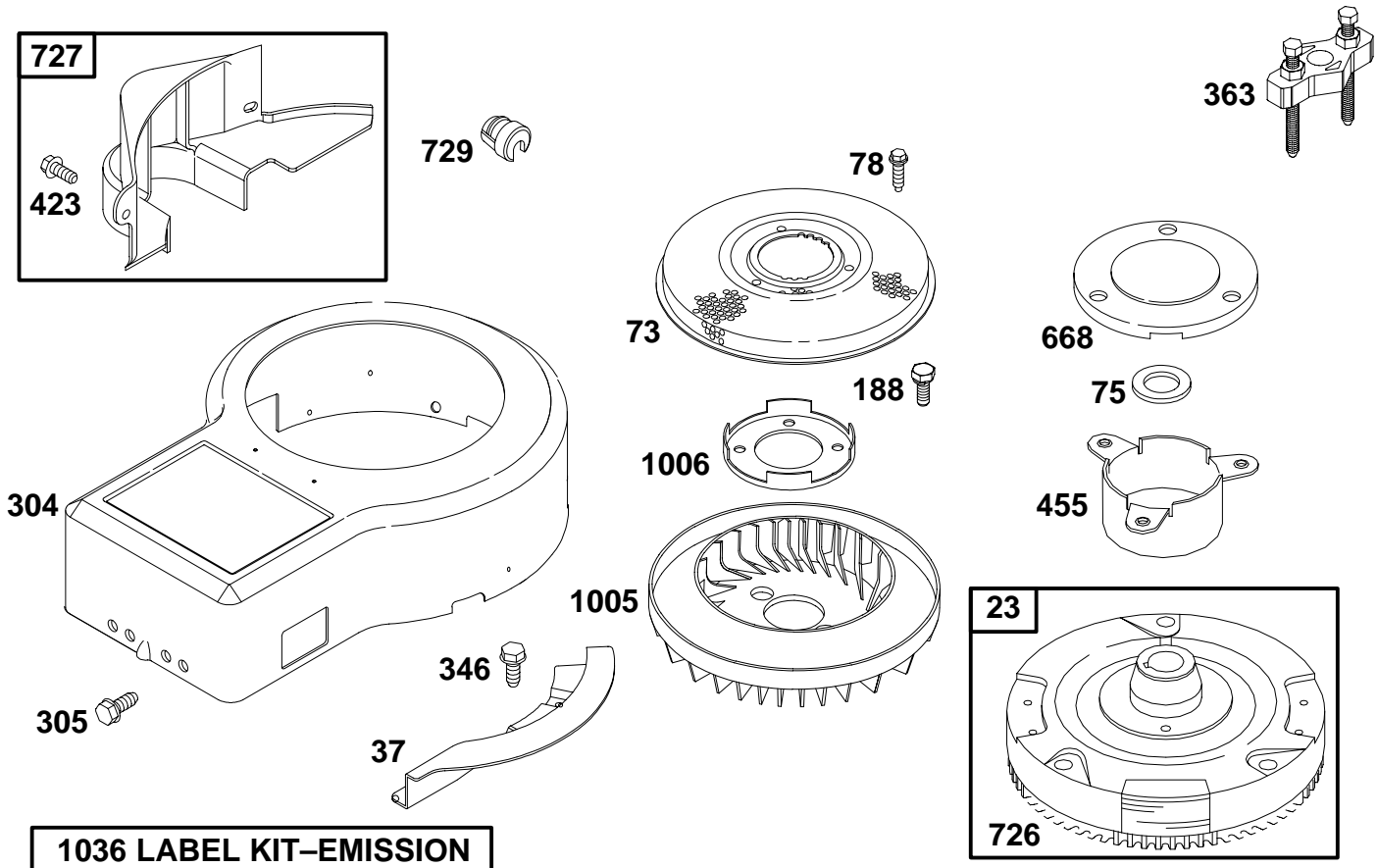

1036 LABEL KIT-EMISSION

REF. NO.	PART NO.	DESCRIPTION	REF. NO.	PART NO.	DESCRIPTION	REF. NO.	PART NO.	DESCRIPTION
23	492326	Flywheel	305	94786	Screw-Hex.	727	490324	Cover-Starter Drive
37	224502	Guard-Flywheel	346	93705	Screw-Hex.	729	281159	Clip-Wire
73	224517	Screen-Rotating	363	19203	Flywheel Puller	1005	280687	Fan-Flywheel
75	224061	Washer-Flywheel	423	94073	Screw-Shoulder	1006	224413	Retainer-Fan
78	94626	Screw-Phillips	455	222561	Cup-Flywheel	1036	499361	Label Kit-Emission Used on Type No(s). 0604, 0613.
188	94627	Screw-Hex.	668	280848	Spacer			
304	496319	Housing-Blower	726	392134	Gear-Ring (Includes Mounting Hardware)			
		Note						
		494269 Housing-Blower (Used Before Code Date 93091300).						

★ Included in Gasket Set-Part Number 494241.
● Included in Carburetor Kit-See Ref. 121.

◆ Included in Carburetor Gasket Set-Part No. 494385.
⊙ Included in Valve Overhaul Gasket Set-Part No. 498539.

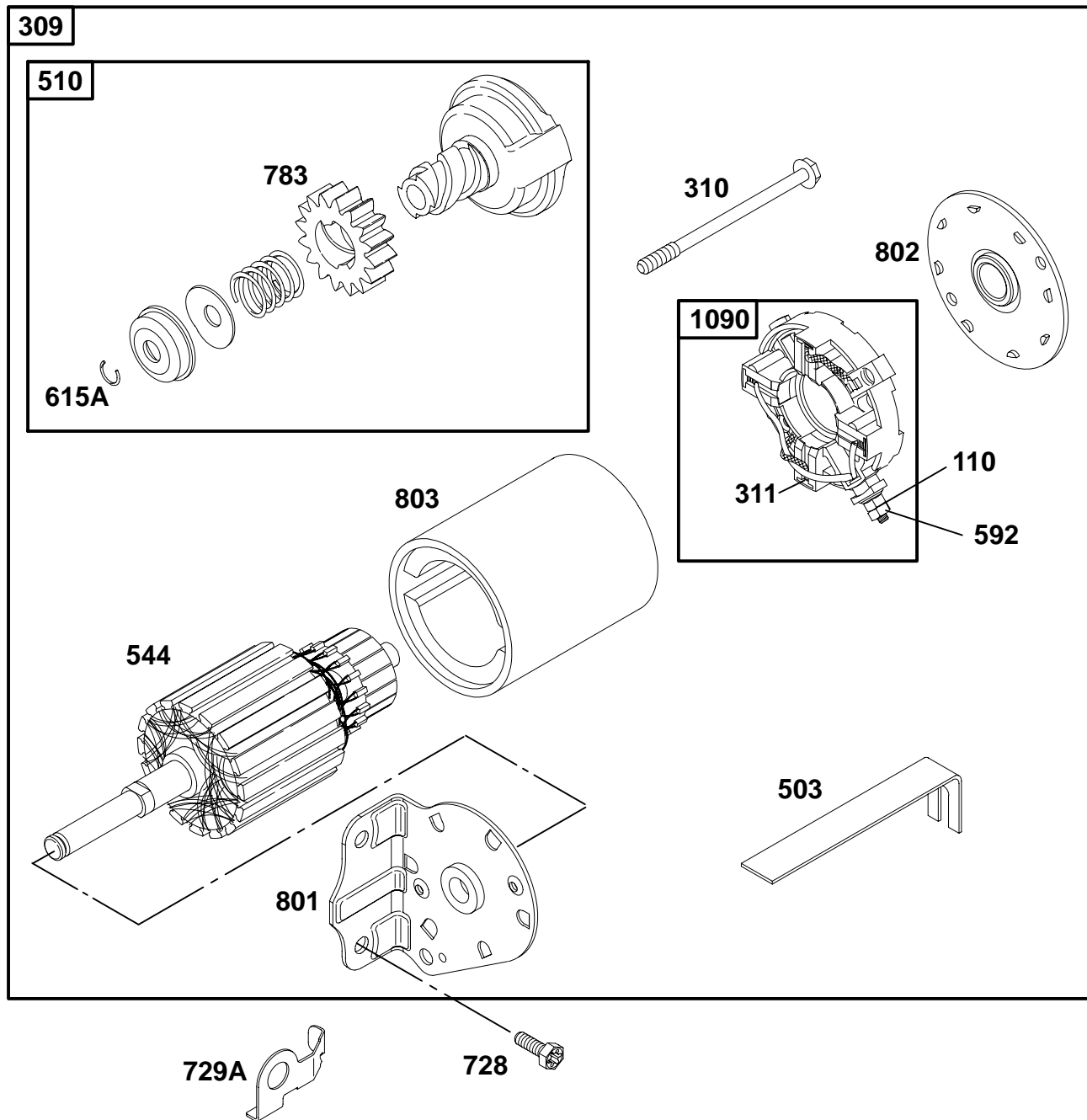

REF. NO.	PART NO.	DESCRIPTION	REF. NO.	PART NO.	DESCRIPTION	REF. NO.	PART NO.	DESCRIPTION
110	225137	Washer-Flat	544	497603	Armature-Starter	783	280104	Gear-Starter
309	497595	Motor-Starter	592	92278	Nut-Hex.	801	497626	Cap-Drive
310	94003	Screw-Hex.	615A	263080	Ring-Retainer	802	497607	Cap-End
311	497608	Brush Set	728	94473	Screw-Torx®Hex	803	497604	Housing-Starter
503	806000	Strap-Starter	729A	225170	Clip-Wire	1090	497605	Retainer-Brush
510	497606	Drive-Starter						

★ Included in Gasket Set-Part Number 494241.
 ● Included in Carburetor Kit-See Ref. 121.

◆ Included in Carburetor Gasket Set-Part No. 494385.
 ◊ Included in Valve Overhaul Gasket Set-Part No. 498539.

285700 to 285799

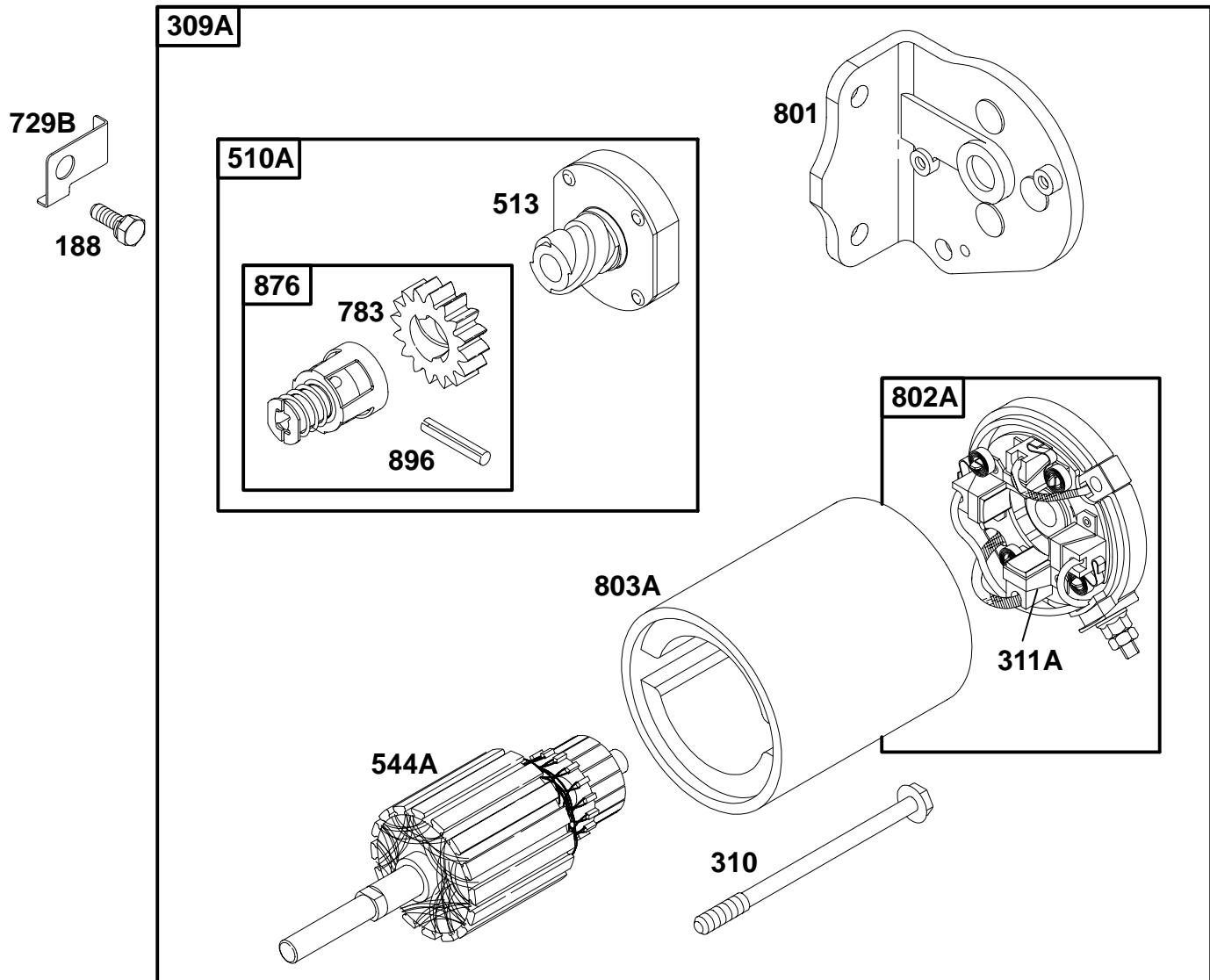

REF. NO.	PART NO.	DESCRIPTION	REF. NO.	PART NO.	DESCRIPTION	REF. NO.	PART NO.	DESCRIPTION
188	94627	Screw-Hex.	510A	495878	Drive-Starter	801	394856	Cap-Drive
309A	394805	Motor-Starter (12V with 3 5/8" Housing Length).	513	398003	Clutch-Drive	802A	395537	Cap-End
310	94003	Screw-Hex.	544A	390837	Armature-Starter	803A	398159	Housing-Starter
311A	395538	Brush Set	729B	224723	Clip-Wire	876	495877	Kit-Gear
			783	280104	Gear-Starter	896	94288	Pin-Drive Retainer

★ Included in Gasket Set-Part Number 494241.
 ● Included in Carburetor Kit-See Ref. 121.

◆ Included in Carburetor Gasket Set-Part No. 494385.
 ◊ Included in Valve Overhaul Gasket Set-Part No. 498539.

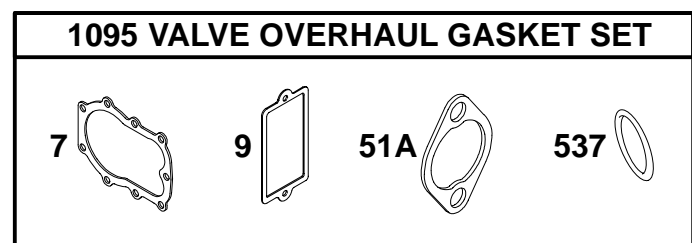
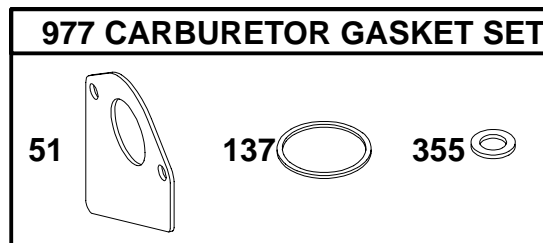
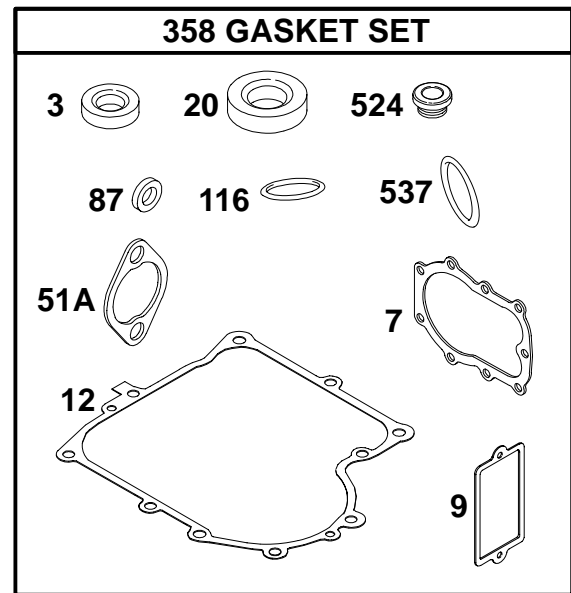
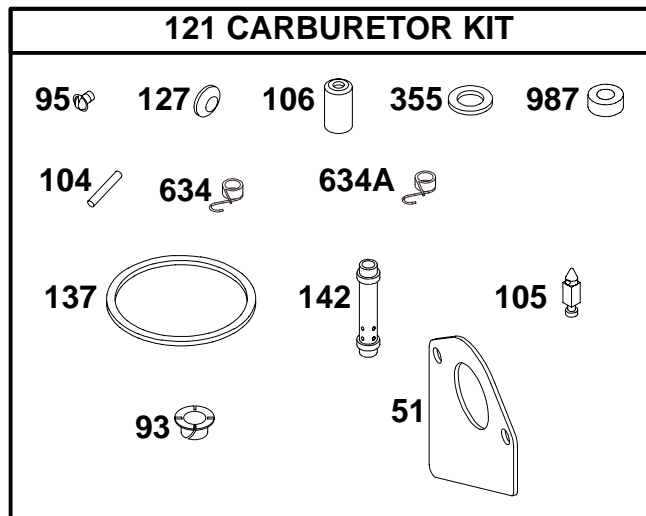

REF. NO.	PART NO.	DESCRIPTION	REF. NO.	PART NO.	DESCRIPTION	REF. NO.	PART NO.	DESCRIPTION
3	★391086	Seal-Oil	106	●231854	Seat-Inlet	142	●497736	Nozzle-Carburetor (Standard) (LMT 92,96)
7	∅★271866	Gasket-Cylinder Head	116	★270920	Seal-O-Ring	Note ●497566 Nozzle-Carb (Standard) (LMT 37,41,81,157)		
9	∅★27803	Gasket-Breather	121	499220	Carburetor Kit (Used After Code Date 96072500). (LMT 92, 96)	355	●◆281164	Washer-Seal
12	★271916	Gasket-Crankcase (.015" Thick)	Note 499231 Carburetor Kit (Used After Code Date 96072500). (LMT 157) 497481 Carburetor Kit (Used Before Code Date 96072600).		524	★281370	Seal-Fill Tube	
		★271997 Gasket-Crankcase (.005" Thick)			537	∅★281106	Gasket-Air Cleaner	
		★271996 Gasket-Crankcase (.009" Thick)			634	●494453	Seal-Spring Assembly (Manual Choke)	
20	★291675	Seal-Oil	127	●	Plug-Welch (Sold in Kit Only)	634A	●494455	Seal-Spring Assembly (Choke A Matic)
51	●◆272465	Gasket-Intake	137	●◆281165	Gasket-Float Bowl	977	494385	Gasket Set-Carburetor
51A	∅★272554	Gasket-Intake			987	●281166	Seal-Throttle Shaft	
87	★491323	Seal-Governor Shaft			1095	498539	Gasket Set-Valve Overhaul	
93	●281346	Bushing-Throttle Shaft						
95	●94098	Screw-Choke/Throttle						
104	●231789	Pin-Float Hinge						
105	●231855	Valve-Needle						

★ Included in Gasket Set-Part Number 494241.
 ● Included in Carburetor Kit-See Ref. 121.

◆ Included in Carburetor Gasket Set-Part No. 494385.
 ∅ Included in Valve Overhaul Gasket Set-Part No. 498539.