

- 1 BOX, FUSE
- 2 LIGHTS, INDICATOR
- 3 SWITCH, KEY
- 4 CONTROL, LEFT HAND
- 5 SWITCH, BRAKE HANDLE
- 6 COIL, IGNITION
- 7 CDI
- 8 RELAY, STARTER
- 9 RELAY, NEUTRAL
- 10 MOTOR, STARTER
- 11 BATTERY, 12V
- 12 REGULATOR/RECTIFIER
- 13 MAGNETO
- 14 TALLLIGHT
- 15 SWITCH, FOOT BRAKE
- 16 SWITCH, REVERSE
- 17 SWITCH, GEAR
- 18 CONNECTOR, ACCESSORY
- 19 HEADLIGHT, LOW-BEAM LEFT
- 20 HEADLIGHT, HIGH-BEAM LEFT
- 21 HEADLIGHT, LOW-BEAM RIGHT
- 22 HEADLIGHT, HIGH-BEAM RIGHT

NOTES  
 1 CONNECTORS VIEWED FROM MATING SURFACE SIDE.  
 2 ● MALE PIN TERMINAL.  
 ○ FEMALE RECEPTACLE TERMINAL.

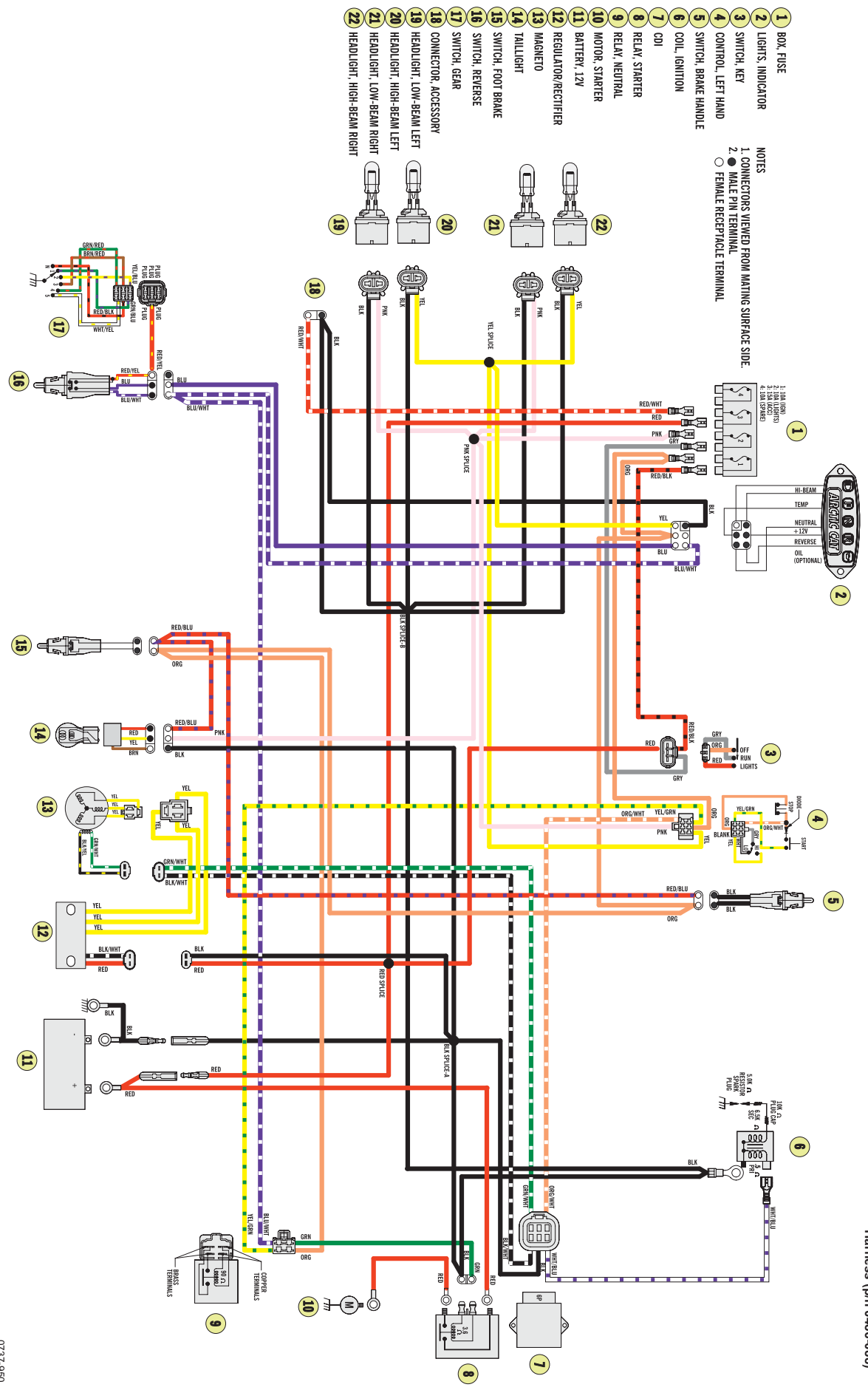

Wiring Diagram (250)  
 Harness (p/n 0486-088)

- 1 FUSE BOX
- 2 SPEEDOMETER
- 3 SWITCH, KEY
- 4 CONTROL, L. HAND
- 5 SWITCH, BRAKE HANDLE
- 6 COIL, IGNITION
- 7 CDI
- 8 RELAY, STARTER
- 9 RELAY, NEUTRAL
- 10 MOTOR, STARTER
- 11 BATTERY, 12V
- 12 CONNECTOR, SWITCHED ACCESSORY
- 13 REGULATOR/RECTIFIER
- 14 MEGNETO
- 15 TAILLIGHT
- 16 SWITCH, FOOT BRAKE
- 17 CONNECTOR, REAR ACCESSORY
- 18 SWITCH, OIL TEMP.
- 19 SWITCH, GEAR
- 20 DIODE ASSY.
- 21 SWITCH, REVERSE
- 22 SWITCH, BRAKE PRESSURE
- 23 CONNECTOR, FRONT ACCESSORY
- 24 HEADLIGHT, L. LOW-BEAM
- 25 HEADLIGHT, L. HI-BEAM
- 26 HEADLIGHT, R. LOW-BEAM
- 27 HEADLIGHT, R. HI-BEAM

NOTES  
 1. CONNECTORS VIEWED FROM MATING SURFACE SIDE.  
 2. ♂ MALE PIN TERMINAL  
 ○ ♀ FEMALE RECEPTACLE TERMINAL

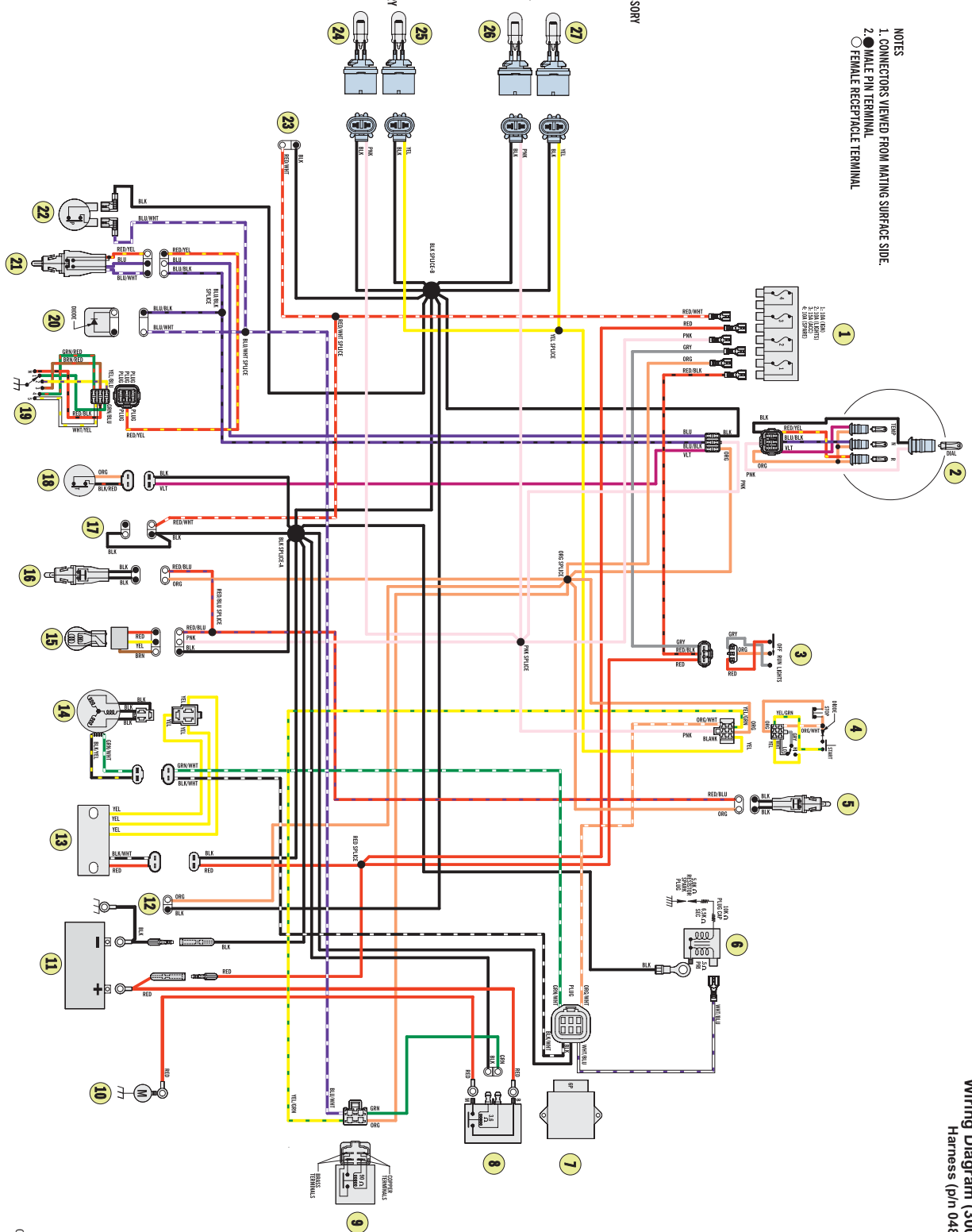

Wiring Diagram (300 4x4)  
 Harness (p/n 0486-150)

- 1 SWITCH, 2WD/4WD
- 2 SWITCH, TEMP. LIGHT
- 3 SENSOR, SPEEDO
- 4 LCD, MULTIFUNCTION
- 5 CONTROL, LEFT HANDED
- 6 SWITCH, BRAKE HANDLE
- 7 SWITCH, KEY
- 8 SWITCH, REVERSE
- 9 CONNECTOR, REAR ACCESSORY
- 10 TAILLIGHT
- 11 COIL, IGNITION
- 12 CDI
- 13 RELAY, STARTER
- 14 BATTERY, 12V
- 15 MOTOR, STARTER
- 16 GROUND, ENGINE/BATTERY
- 17 REGULATOR/RECTIFIER
- 18 MAGNETO
- 19 CONNECTOR, SWITCHED ACCESSORY
- 20 PDM (POWER DISTRIBUTION MODULE)
- 21 SWITCH, FOOT BRAKE
- 22 SWITCH, TEMP. FAN
- 23 MOTOR, FAN
- 24 DIODE, FAN
- 25 SWITCH, ENG. NEUTRAL
- 26 ACTUATOR, SELECT 2WD/4WD
- 27 SWITCH, 4WD DIFF. LOCK
- 28 CONNECTOR, ACCESSORY FRONT
- 29 HEADLIGHT, L. LOWBEAM
- 30 HEADLIGHT, L. HI-BEAM
- 31 HEADLIGHT, R. LOWBEAM
- 32 HEADLIGHT, R. HI-BEAM
- 33 CHOKE, ELECTRIC
- 34 HARNESS, ELECTRIC CHOKE

NOTES:  
 1. CONNECTORS VIEWED FROM MATING SURFACE SIDE.  
 2. ● MALE PIN TERMINAL  
 ○ FEMALE RECEPTACLE TERMINAL

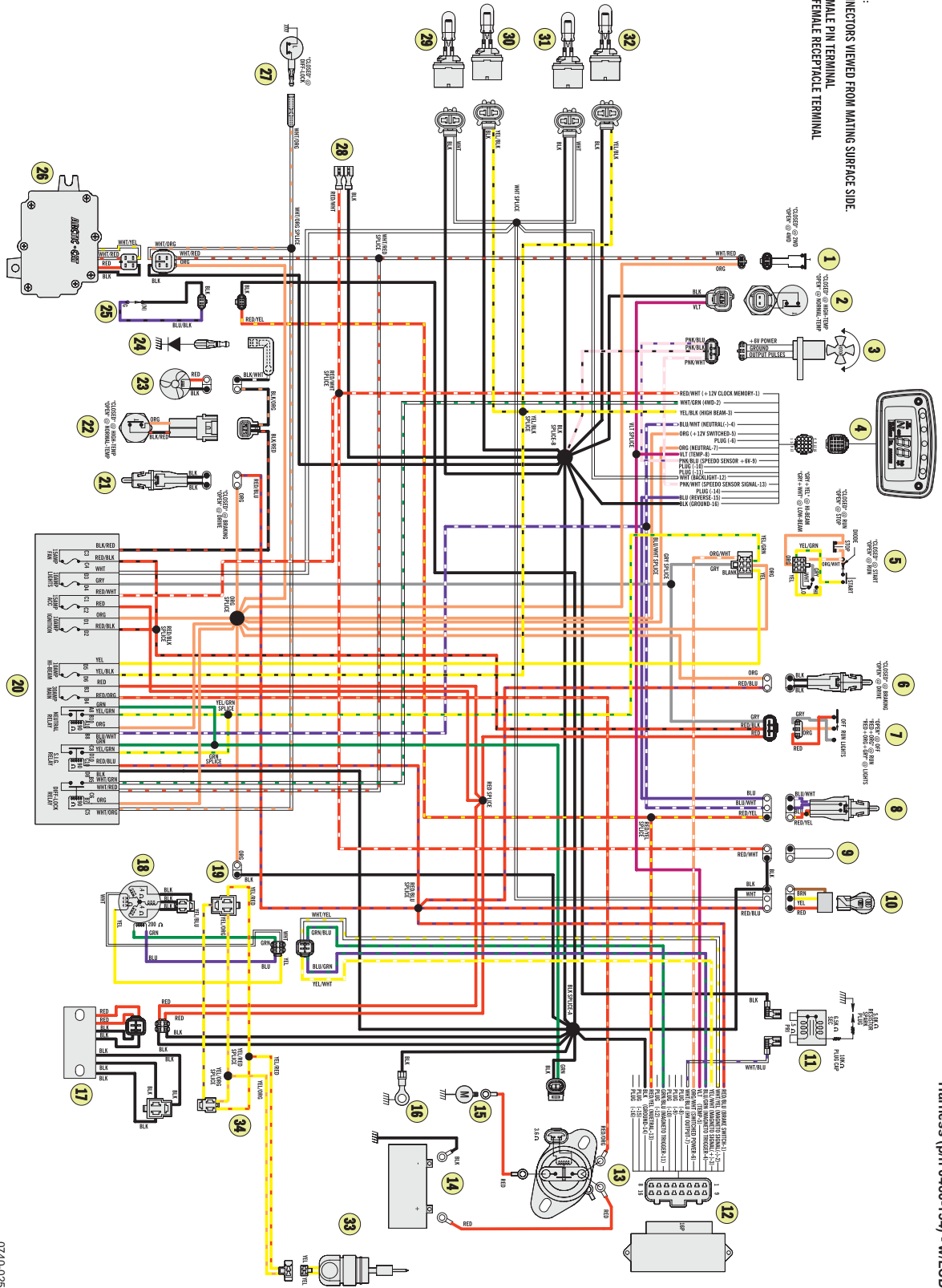

Wiring Diagram (400 FIS Manual Transmission)  
 Harness (p/n 0486-154) - w/LCD

- 1 SWITCH, TEMP. LIGHT
- 2 SWITCH, BRAKE PRESSURE
- 3 LIGHTS, INDICATOR
- 4 CONTROL, L. HAND
- 5 SWITCH, BRAKE HANDLE
- 6 SWITCH, KEY
- 7 SWITCH, REVERSE
- 8 CONNECTOR, REAR ACCESSORY
- 9 TALLLIGHT
- 10 COIL, IGNITION
- 11 CDI
- 12 RELAY, STARTER
- 13 BATTERY, 12V
- 14 MOTOR, STARTER
- 15 GROUND, ENGINE/BATTERY
- 16 REGULATOR/RECTIFIER
- 17 MAGNETO
- 18 CONNECTOR, SWITCHED ACCESSORY
- 19 RELAY, NEUTRAL
- 20 FUSE BOX
- 21 SWITCH, FOOT BRAKE
- 22 SWITCH, TEMP-FAN
- 23 MOTOR, FAN
- 24 DIODE, FAN
- 25 DIODE ASSEMBLY
- 26 SWITCH, ENGINE NEUTRAL
- 27 HEADLIGHT, L. LOWBEAM
- 28 HEADLIGHT, L. HI-BEAM
- 29 HEADLIGHT, R. LOWBEAM
- 30 HEADLIGHT, R. HI-BEAM
- 31 HEADLIGHT, R. HI-BEAM
- 32 CHOKE, ELECTRIC
- 33 HARNESS, ELECTRIC CHOKE

NOTES  
 1. CONNECTORS VIEWED FROM MATING SURFACE SIDE.  
 2. ♂ MALE PIN TERMINAL.  
 ○ ♀ FEMALE RECEPTACLE TERMINAL.

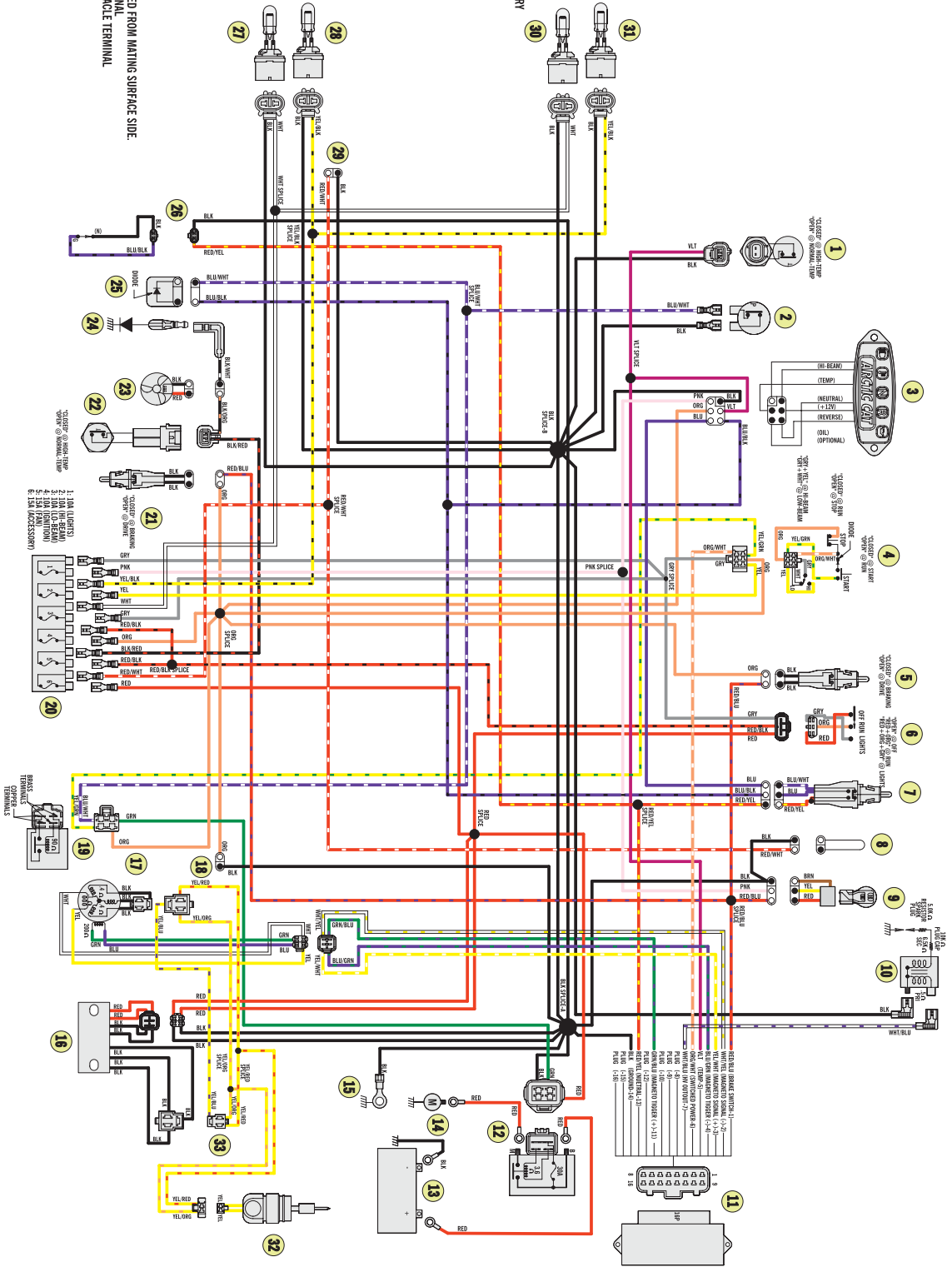

Wiring Diagram (400 ACT Manual Transmission) Harness (p/n 0486-169)

- 1 SWITCH, TEMP. FAN
- 2 SWITCH, BRAKE PRESSURE
- 3 SPEEDOMETER
- 4 CONTROL, LEFT HANDED
- 5 OVERRIDE, REVERSE
- 6 SWITCH, BRAKE HANDLE
- 7 SWITCH, KEY
- 8 CONNECTOR, REAR ACCESSORY
- 9 TALLIGHT
- 10 COIL, IGNITION
- 11 CDI
- 12 RELAY, STARTER
- 13 BATTERY, 12V
- 14 MOTOR, STARTER
- 15 GROUND, ENGINE/BATTERY
- 16 REGULATOR/RECTIFIER
- 17 MAGNETO
- 18 CONNECTOR, SWITCHED ACCESSORY
- 19 RELAY, NEUTRAL
- 20 FUSE BOX
- 21 SWITCH, FOOT BRAKE
- 22 SWITCH, LIGHT TEMP.
- 23 MOTOR, FAN
- 24 DIODE, FAN
- 25 SWITCH, GEAR
- 26 DIODE ASSEMBLY
- 27 HEADLIGHT, L. LOWBEAM
- 28 HEADLIGHT, L. HI-BEAM
- 29 CONNECTOR, ACC. FRONT
- 30 HEADLIGHT, R. LOWBEAM
- 31 HEADLIGHT, R. HI-BEAM
- 32 CHOKE, ELECTRIC
- 33 HARNESS, ELECTRIC CHOKE

NOTES  
 1. CONNECTORS VIEWED FROM MATING SURFACE SIDE.  
 2. MALE PIN TERMINAL.  
 3. FEMALE RECEPTACLE TERMINAL.

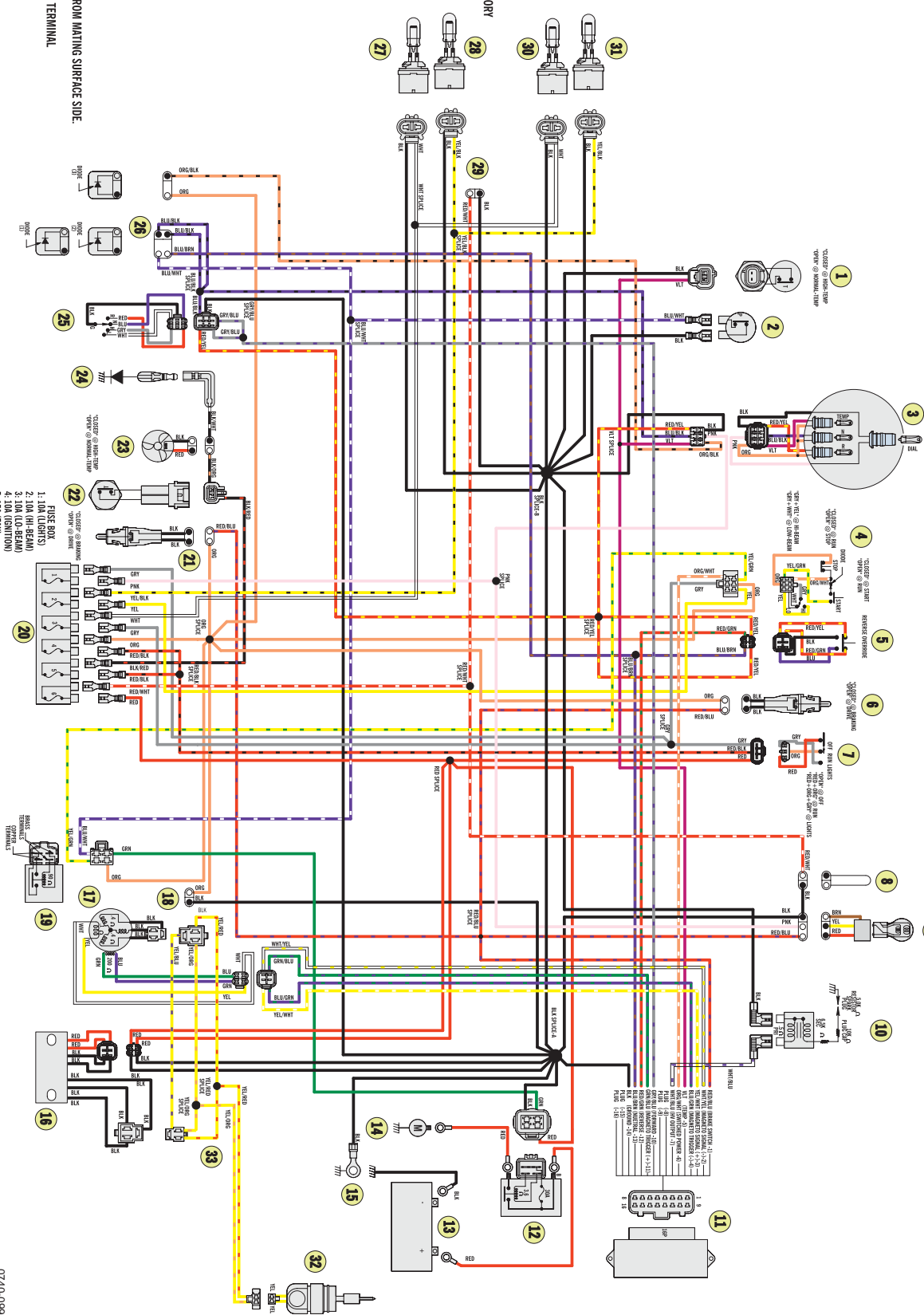

Wiring Diagram (400 ACT Automatic Transmission) Harness (p/n 0486-165)

- 1 SWITCH, 2WD/4WD
- 2 SWITCH, TEMP. LIGHT
- 3 SENSOR, SPEED
- 4 LCD, MULTIFUNCTION
- 5 CONTROL, LEFT HANDED
- 6 OVERRIDE, REVERSE
- 7 SWITCH, BRAKE HANDLE
- 8 SWITCH, KEY
- 9 CONNECTOR, REAR ACCESSORY
- 10 TAILLIGHT
- 11 COLL. LIGHTNING
- 12 CDI
- 13 RELAY, STARTER
- 14 BATTERY, 12V
- 15 MOTOR, STARTER
- 16 GROUND, ENGINE/BATTERY
- 17 REGULATOR/RECTIFIER
- 18 MAGNETO
- 19 CONNECTOR, SWITCHED ACCESSORY
- 20 P.M. (POWER DISTRIBUTION MODULE)
- 21 SWITCH, FOOT BRAKE
- 22 MOTOR, FAN
- 23 SWITCH, TEMP. FAN
- 24 DIODE, FAN
- 25 SWITCH, ENGINE NEUTRAL
- 26 ACTUATOR, SELECT 2WD/4WD
- 27 SWITCH, 4WD DIFF. LOCK
- 28 HEADLIGHT, L. LOWBEAM
- 29 HEADLIGHT, L. HI-BEAM
- 30 HEADLIGHT, R. HI-BEAM
- 31 HEADLIGHT, R. LOWBEAM
- 32 HEADLIGHT, ACCESSORY FRONT
- 33 CHOKER, ELECTRIC
- 34 HARNESS, ELECTRIC CHOKER

NOTES  
 1. CONNECTORS VIEWED FROM MATING SURFACE SIDE.  
 2. ● MALE PIN TERMINAL  
 ○ FEMALE RECEPTACLE TERMINAL

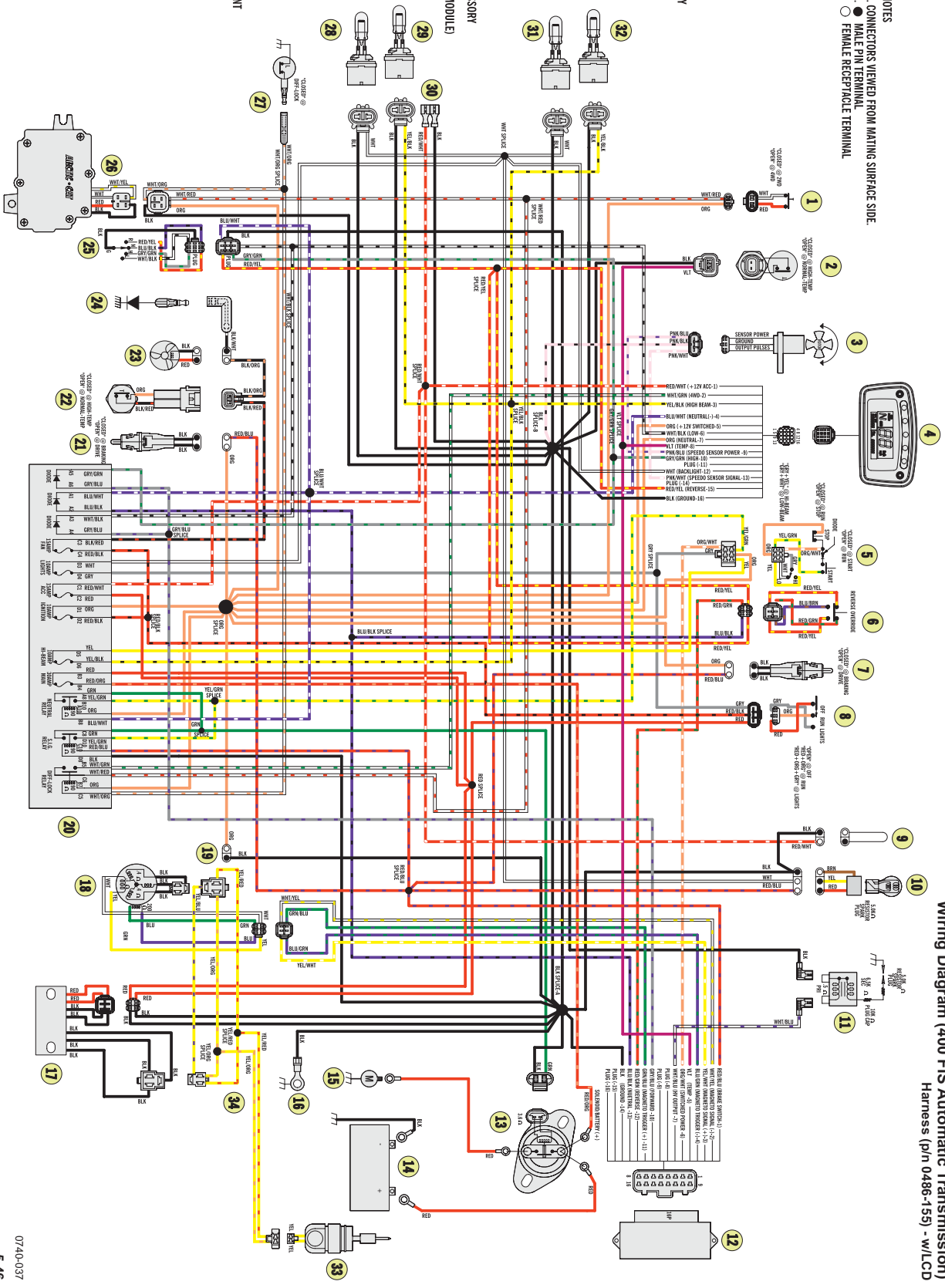

Wiring Diagram (400 FIS Automatic Transmission)  
 Harness (p/n 0486-155) - W/LCD

- 1 SWITCH, 2WD/4WD
- 2 SWITCH, LIGHT TEMP.
- 3 SPEEDOMETER
- 4 GAUGE, FUEL
- 5 CONTROL, LEFT HANDED
- 6 OVERRIDE, REVERSE
- 7 SWITCH, BRAKE HANDLE
- 8 SWITCH, KEY
- 9 CONNECTOR, REAR ACCESSORY
- 10 TAILLIGHT
- 11 COIL, IGNITION
- 12 SENSOR, FUEL LEVEL
- 13 CDI
- 14 RELAY, STARTER
- 15 BATTERY, 12V
- 16 MOTOR, STARTER
- 17 GROUND, ENGINE/BATTERY
- 18 CHOKE, ELECTRIC
- 19 HARNESS, ELECTRIC CHOKE
- 20 REGULATOR/RECTIFIER
- 21 MAGNETO
- 22 CONNECTOR, SWITCHED ACCESSORY
- 23 PDM (POWER DISTRIBUTION MODULE)
- 24 SWITCH, FOOT BRAKE
- 25 SWITCH, TEMP. FAN
- 26 MOTOR, FAN
- 27 DIODE, FAN
- 28 SWITCH, GEAR
- 29 ACTUATOR, SELECT 2WD/4WD
- 30 HEADLIGHT, L. LOWBEAM
- 31 HEADLIGHT, L. HI-BEAM
- 32 CONNECTOR, ACC. FRONT
- 33 HEADLIGHT, R. LOWBEAM
- 34 HEADLIGHT, R. HI-BEAM

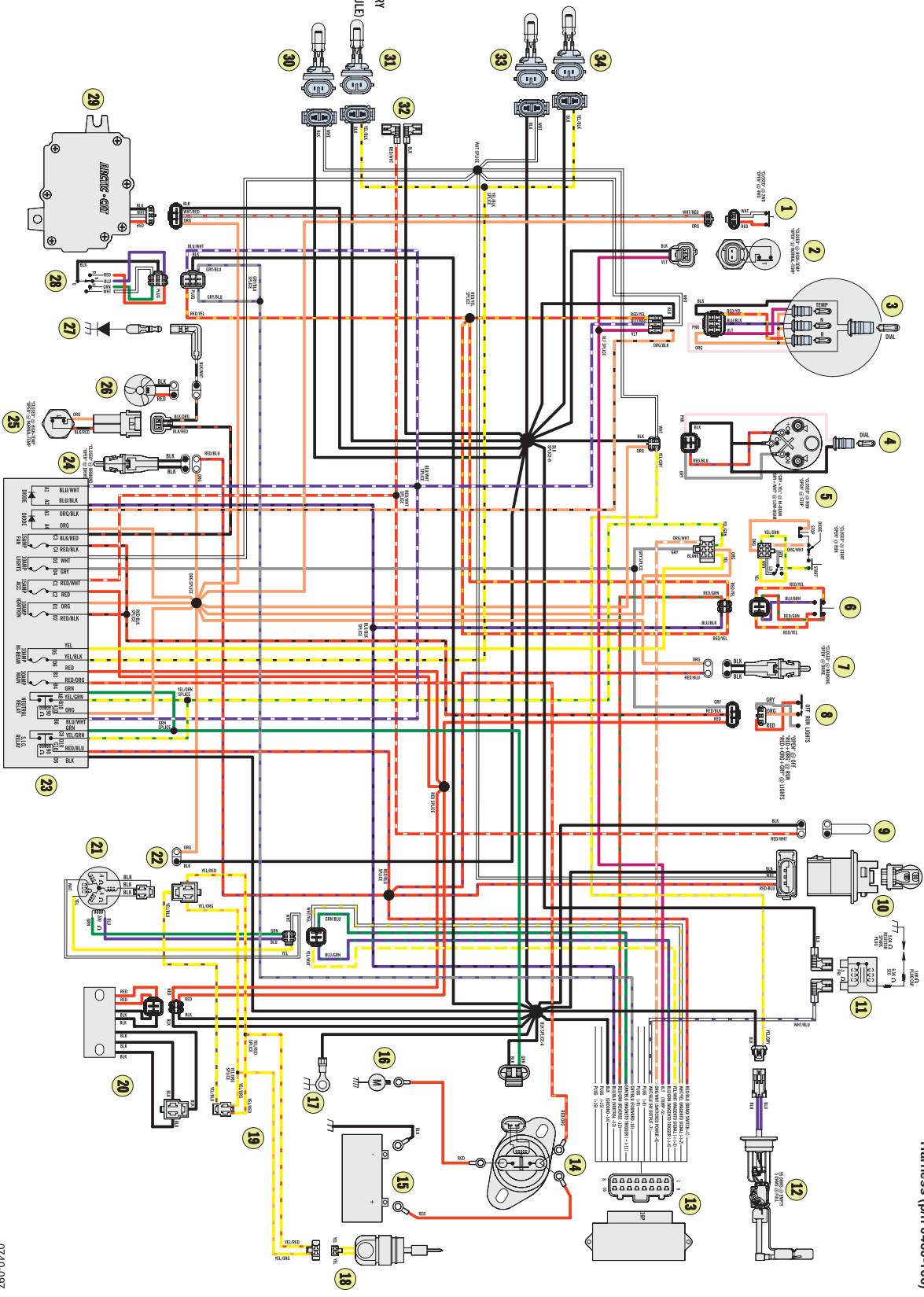

Wiring Diagram (400 TBX)  
Harness (p/n 0486-166)

- 1 SWITCH, ENGINE NEUTRAL
- 2 SWITCH, REVERSE
- 3 SWITCH, 2WD/4WD
- 4 LIGHT, TEMP. SWITCH
- 5 SENSOR, SPEEDO
- 6 LCD, MULTIFUNCTION
- 7 CONTROL, LEFT HANDED
- 8 SWITCH, BRAKE HANDLE
- 9 SWITCH, KEY
- 10 CONNECTOR, REAR ACCESSORY
- 11 TAILLIGHT
- 12 COIL, IGNITION
- 13 SENSOR, FUEL LEVEL
- 14 CDI
- 15 RELAY, STARTER
- 16 BATTERY, 12V
- 17 MOTOR, STARTER
- 18 GROUND, ENGINE BATTERY
- 19 CHOKE, ELECTRIC
- 20 HARNESS, ELECTRIC CHOKE
- 21 REGULATOR/RECTIFIER
- 22 MAGNETO
- 23 CONNECTOR, SWITCHED ACCESSORY
- 24 PWM (POWER DISTRIBUTION MODULE)
- 25 SWITCH, FOOT BRAKE
- 26 SWITCH, WATER TEMP.
- 27 MOTOR, FAN
- 28 DIODE, FAN
- 29 SWITCH, GEAR
- 30 ACTUATOR, SELECT 2WD/4WD
- 31 SWITCH, 4WD DIFF. LOCK
- 32 HEADLIGHT, L. LOW-BEAM
- 33 HEADLIGHT, L. HI-BEAM
- 34 CONNECTOR, ACC. FRONT
- 35 HEADLIGHT, R. LOW-BEAM
- 36 HEADLIGHT, R. HI-BEAM

NOTES  
 1. CONNECTORS VIEWED FROM MATING SURFACE SIDE.  
 2. MALE PIN TERMINAL  
 3. FEMALE RECEPTACLE TERMINAL

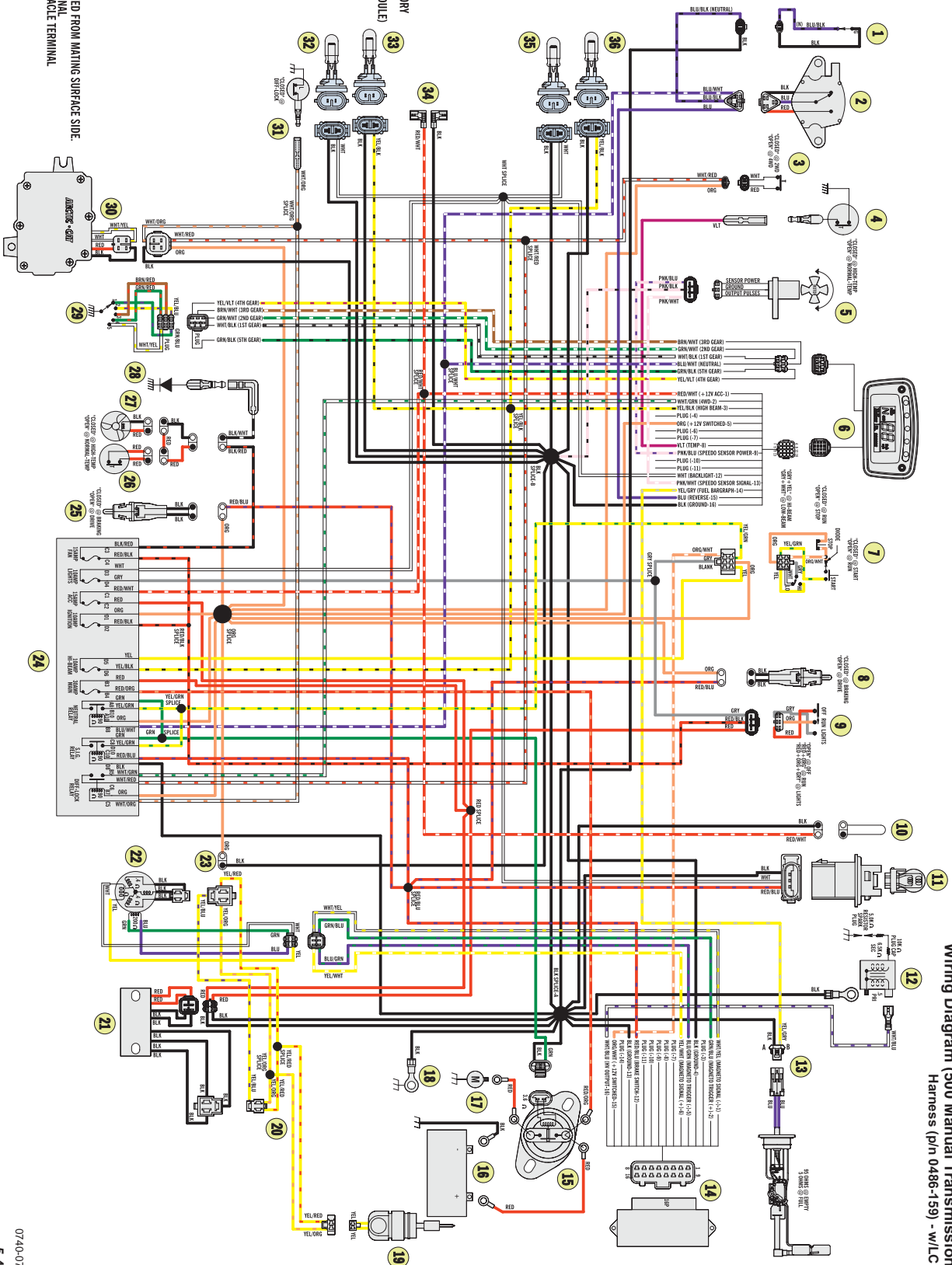

Wiring Diagram (500 Manual Transmission) Harness (p/n 0486-159) - w/LCD



- 1 SWITCH, 2WD/4WD
- 2 SWITCH, WATER TEMP.
- 3 SENSOR, SPEEDO
- 4 LOD, MULTIFUNCTION
- 5 CONTROL, LEFT HANDED
- 6 OVERRIDE, REVERSE
- 7 SWITCH, BRAKE HANDLE
- 8 SWITCH, KEY
- 9 CONNECTOR, REAR ACCESSORY
- 10 TAILLIGHT
- 11 COIL, IGNITION
- 12 SENSOR, FUEL LEVEL
- 13 CDI
- 14 RELAY, STARTER
- 15 BATTERY, 12V
- 16 MOTOR, STARTER
- 17 GROUND, ENGINE/BATTERY
- 18 CHOKE, ELECTRIC
- 19 HARNESS, ELECTRIC CHOKE
- 20 REGULATOR/RECTIFIER
- 21 MAGNETO
- 22 CONNECTOR, SWITCHED ACCESSORY
- 23 PGM (POWER DISTRIBUTION MODULE)
- 24 SWITCH, FOOT BRAKE
- 25 SWITCH, TEMP. FAN
- 26 MOTOR, FAN
- 27 DIODE, FAN
- 28 SWITCH, GEAR
- 29 ACTUATOR, SELECT 2WD/4WD
- 30 SWITCH, 4WD DIFF. LOCK
- 31 HEADLIGHT, L. LOWBEAM
- 32 HEADLIGHT, L. HI-BEAM
- 33 CONNECTOR, ACC. FRONT
- 34 HEADLIGHT, R. LOWBEAM
- 35 HEADLIGHT, R. HI-BEAM

NOTES  
 1. CONNECTORS VIEWED FROM MATING SURFACE SIDE.  
 2. MALE PIN TERMINAL.  
 3. FEMALE RECEPTACLE TERMINAL.

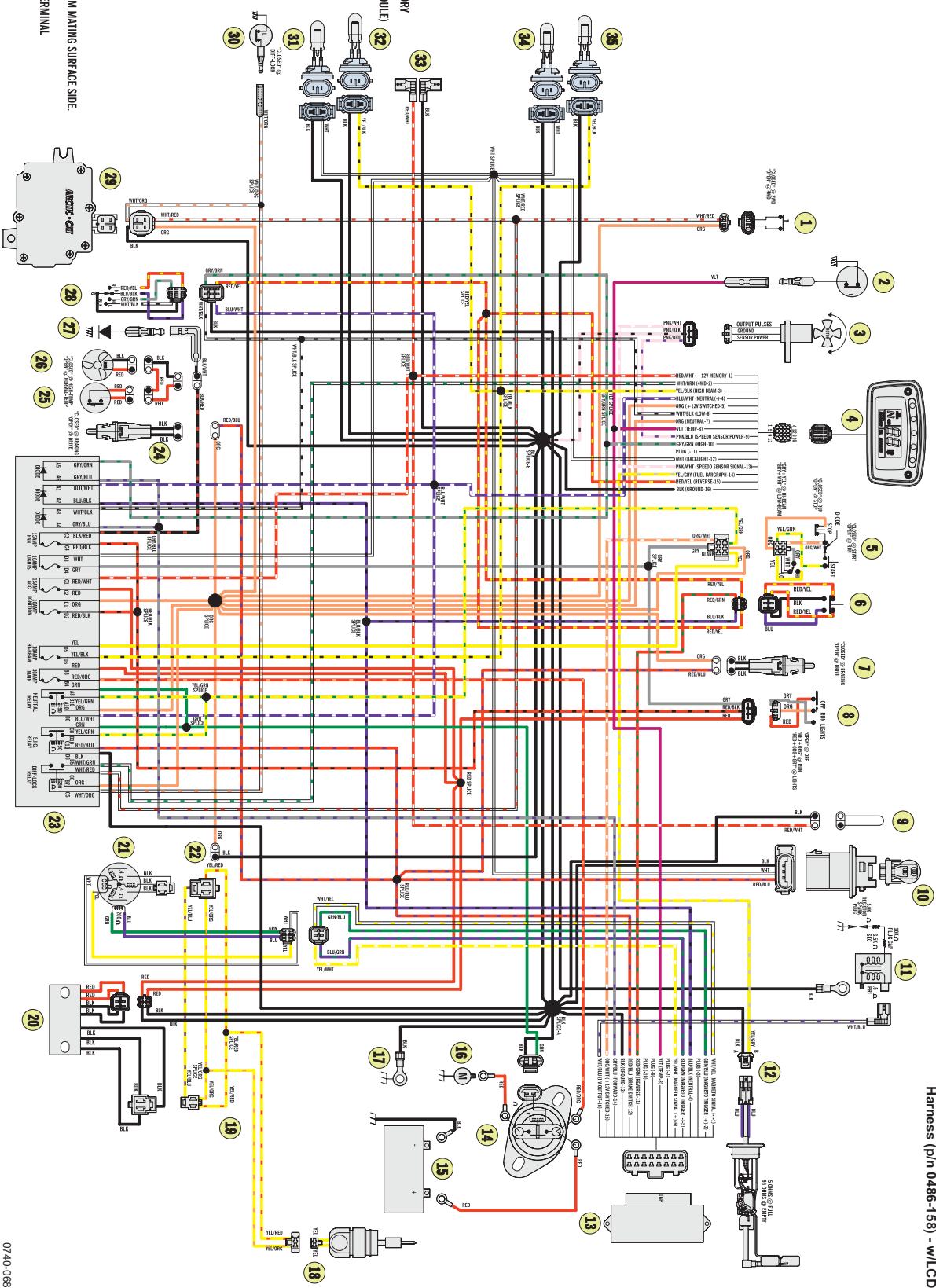

Wiring Diagram (500 Automatic Transmission) Harness (p/n 0486-158) - w/LCD

- 1 SWITCH, 2ND/AWD
- 2 SWITCH, WATER TEMP.
- 3 SENSOR, SPEED
- 4 LCD, MULTIFUNCTION
- 5 CONTROL, LEFT HANDED
- 6 OVERRIDE, REVERSE
- 7 SWITCH, BRAKE HANDLE
- 8 SWITCH, KEY
- 9 CONNECTOR, REAR ACCESSORY
- 10 TAILLIGHT
- 11 COIL, IGNITION
- 12 SENSOR, FUEL LEVEL
- 13 CDI
- 14 RELAY, STARTER
- 15 BATTERY, 12V
- 16 MOTOR, STARTER
- 17 GROUND, ENGINE/BATTERY
- 18 CHOKE, ELECTRIC
- 19 HARNESS, ELECTRIC CHOKE
- 20 REGULATOR/RECTIFIER
- 21 MAGNETO
- 22 CONNECTOR, SWITCHED ACCESSORY
- 23 PDM (POWER DISTRIBUTION MODULE)
- 24 SWITCH, FOOT BRAKE
- 25 FAN, TEMP. SWITCH
- 26 MOTOR, FAN
- 27 DIODE, FAN
- 28 SWITCH, GEAR
- 29 ACTUATOR, SELECT 2ND/AWD
- 30 SWITCH, 4WD DIFF. LOCK
- 31 HEADLIGHT, L. LOWBEAM
- 32 HEADLIGHT, L. HI-BEAM
- 33 CONNECTOR, ACC. FRONT
- 34 HEADLIGHT, R. LOWBEAM
- 35 HEADLIGHT, R. HI-BEAM

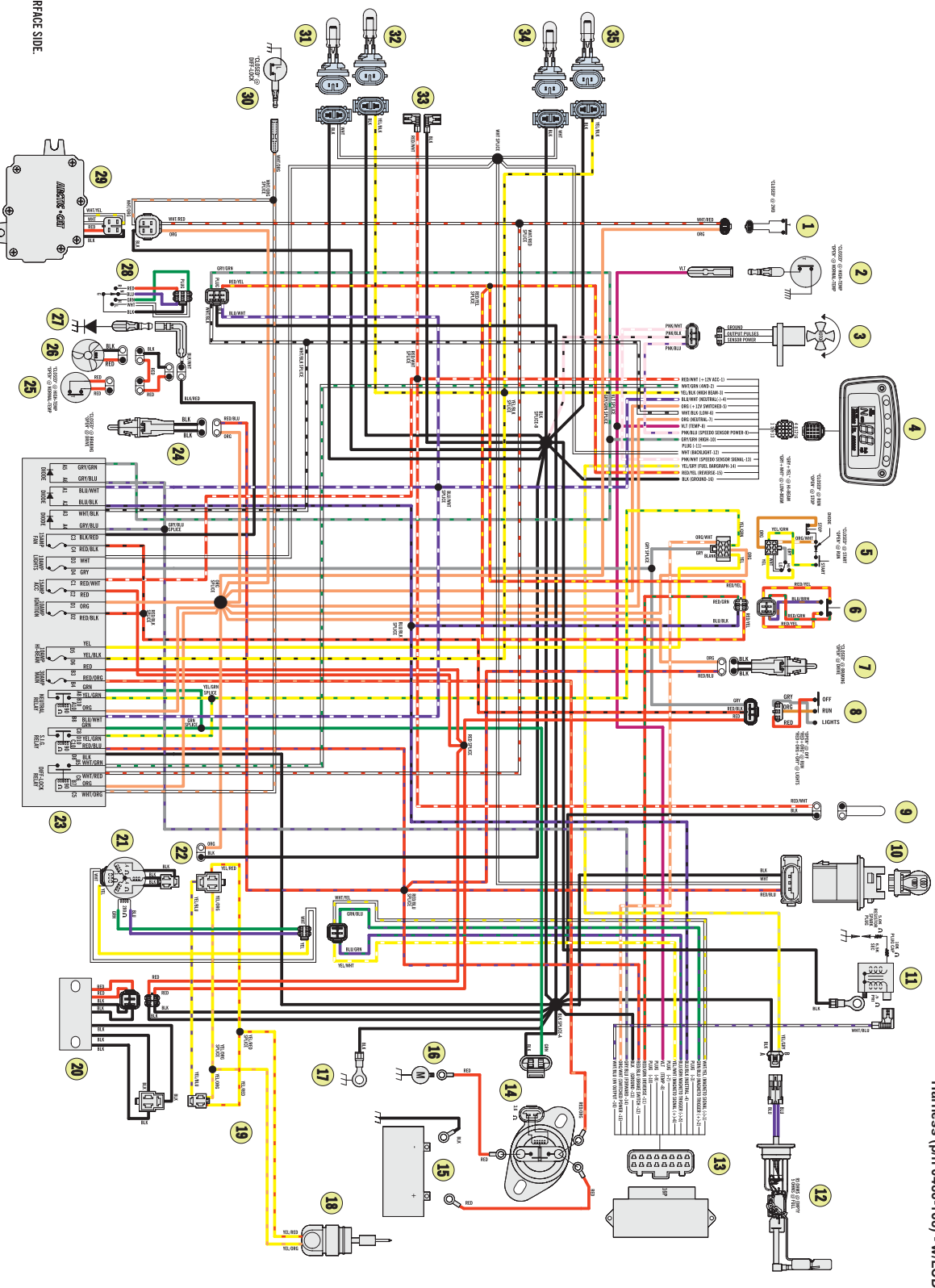

NOTES  
 1. CONNECTORS VIEWED FROM MATING SURFACE SIDE.  
 2. MALE PIN TERMINAL.  
 3. FEMALE RECEPTACLE TERMINAL.

Wiring Diagram (500 TBX)  
 Harness (p/n 0486-168) - w/LCD

- 1 SWITCH, 2ND/AWD
- 2 SWITCH, WATER TEMP.
- 3 SENSOR, SPEED
- 4 LCD, MULTIFUNCTION
- 5 CONTROL, L. HAND
- 6 OVERRIDE REVERSE
- 7 SWITCH, BRAKE HANDLE
- 8 SWITCH, KEY
- 9 CONNECTOR, REAR ACCESSORY
- 10 TAILLIGHT
- 11 COIL, IGNITION
- 12 CDI
- 13 RELAY, STARTER
- 14 MOTOR, STARTER
- 15 BATTERY, 12V
- 16 GROUND, ENGINE/BATTERY
- 17 REGULATOR/RECTIFIER
- 18 MAGNETO
- 19 CONNECTOR, ACCESSORY SWITCHED
- 20 PPM
- 21 SWITCH, FOOT BRAKE
- 22 SWITCH, TEMP. FAN
- 23 MOTOR, FAN
- 24 DIODE, FAN
- 25 SWITCH, GEAR
- 26 ACTUATOR, 2ND/AWD
- 27 HEADLIGHT, L. LOW-BEAM
- 28 HEADLIGHT, L. HI-BEAM
- 29 CONNECTOR, ACC. FRONT
- 30 HEADLIGHT, R. LOW-BEAM
- 31 HEADLIGHT, R. HI-BEAM
- 32 CHOKE, ELECTRIC
- 33 HARNESS, ELECTRIC CHOKE

NOTES  
 1. CONNECTORS VIEWED FROM MATING SURFACE SIDE.  
 2. ● MALE PIN TERMINAL  
 ○ FEMALE RECEPTACLE TERMINAL

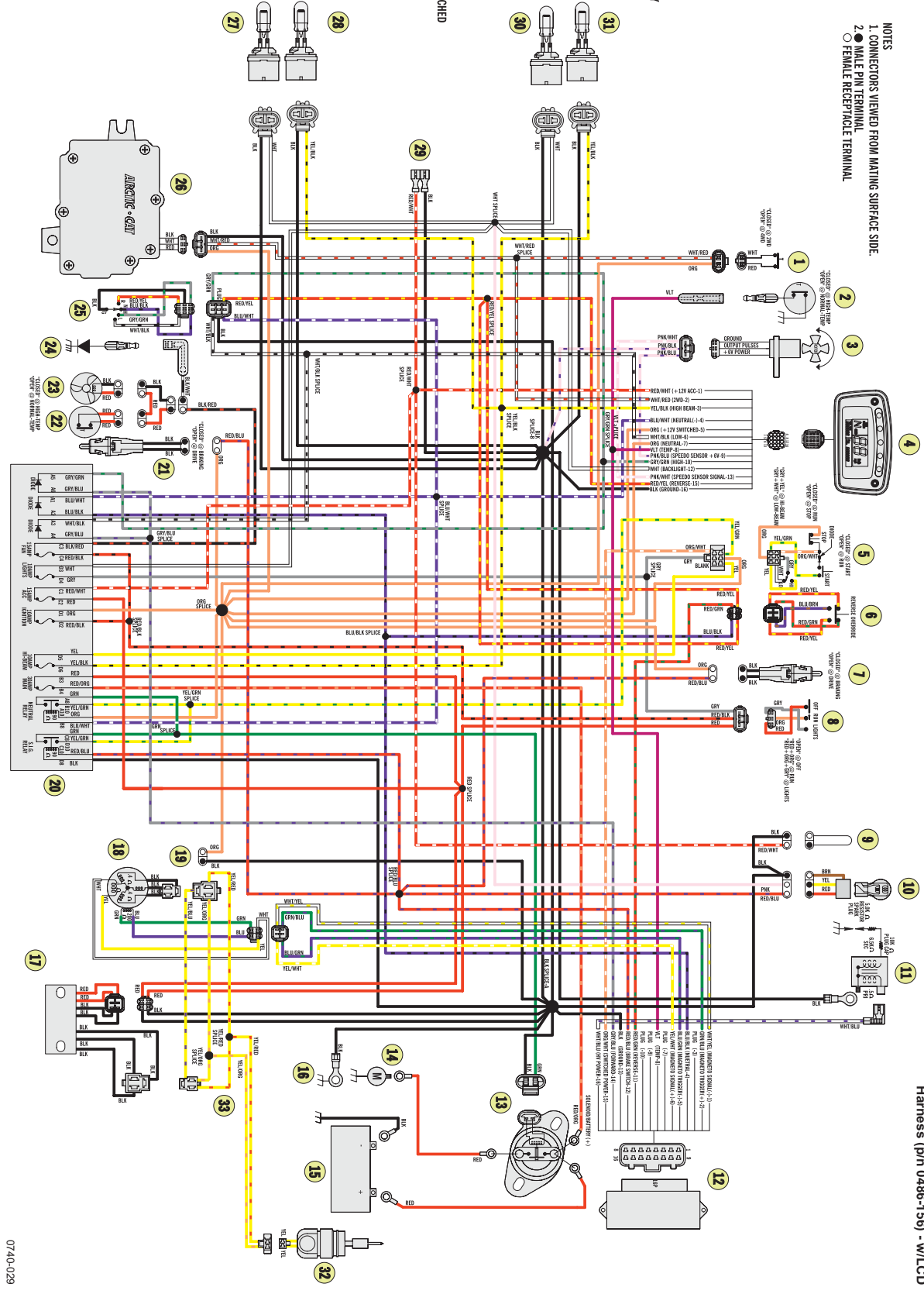

- 1 SWITCH, 2WD/4WD
- 2 SWITCH, WATER TEMP.
- 3 SENSOR, SPEEDO
- 4 LCD, MULTIFUNCTION
- 5 CONTROL, LEFT HANDED
- 6 OVERRIDE, REVERSE
- 7 SWITCH, BRAKE HANDLE
- 8 SWITCH, KEY
- 9 CONNECTOR, REAR ACCESSORY
- 10 TAILLIGHT
- 11 COIL, IGNITION
- 12 SENSOR, FUEL LEVEL
- 13 CDI
- 14 RELAY, STARTER
- 15 BATTERY, 12V
- 16 MOTOR, STARTER
- 17 GROUND, ENGINE/BATTERY
- 18 CHoke, ELECTRIC
- 19 REGULATOR/RECTIFIER
- 20 MAGNETO
- 21 CONNECTOR, SWITCHED ACCESSORY
- 22 PDM (POWER DISTRIBUTION MODULE)
- 23 SWITCH, FOOT BRAKE
- 24 SWITCH, FAN TEMP.
- 25 MOTOR, FAN
- 26 DIODE, FAN
- 27 SWITCH, GEAR
- 28 ACTUATOR, SELECT 2WD/4WD
- 29 SWITCH, 4WD DIFF. LOCK
- 30 HEADLIGHT, L. LOWBEAM
- 31 HEADLIGHT, L. HI-BEAM
- 32 CONNECTOR, ACC. FRONT
- 33 HEADLIGHT, R. LOWBEAM
- 34 HEADLIGHT, R. HI-BEAM

NOTES  
 1. CONNECTORS VIEWED FROM MATING SURFACE SIDE.  
 2. ● MALE PIN TERMINAL  
 3. ○ FEMALE RECEPTACLE TERMINAL

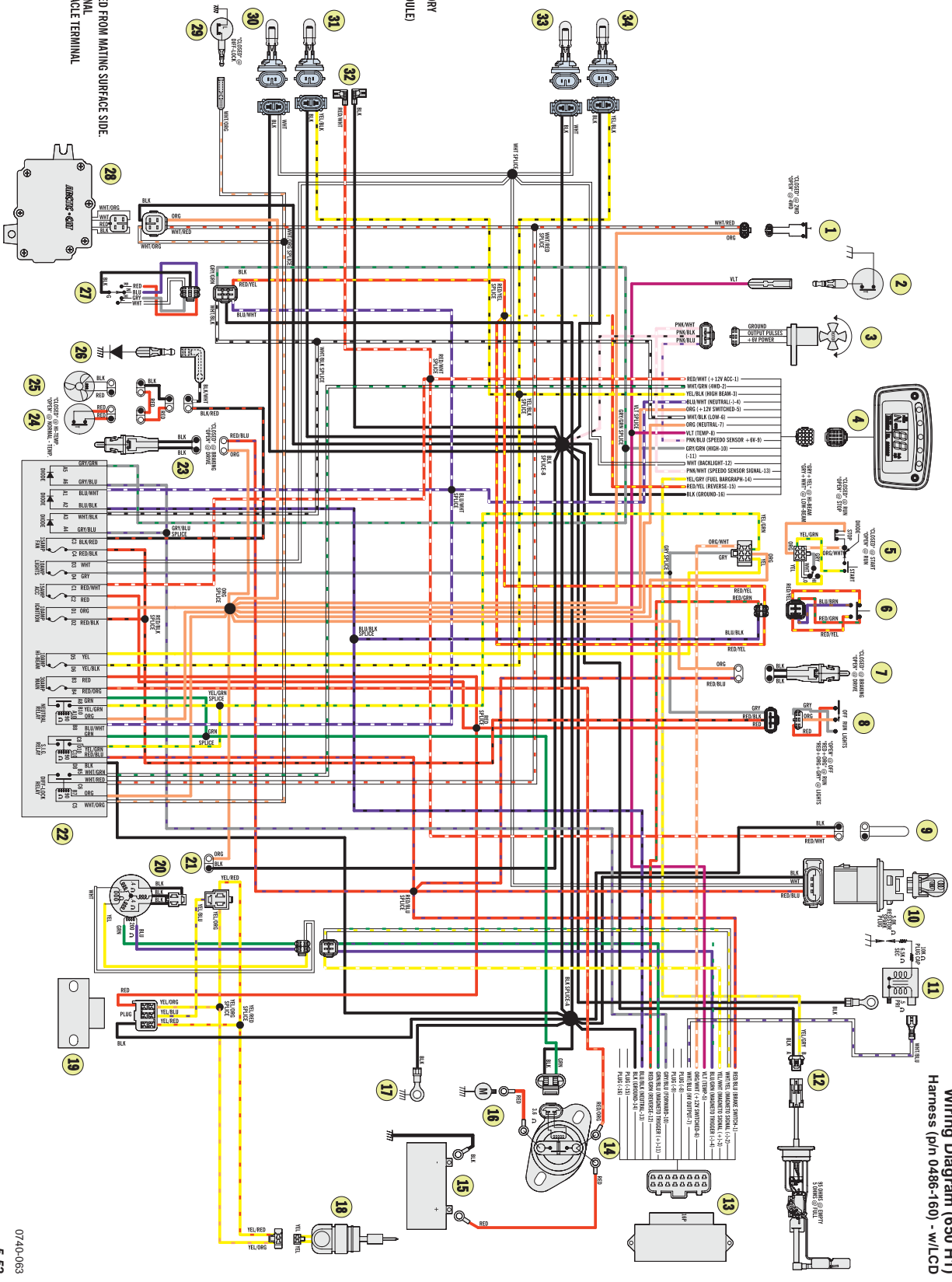

Wiring Diagram (650 H1)  
 Harness (p/n 0486-160) - w/LCD

- 1 SWITCH, OIL PRESSURE
- 2 SWITCH, NEUTRAL
- 3 SWITCH, 2WD/4WD
- 4 SENSOR, SPEED
- 5 LCD, MULTI-FUNCTION
- 6 SENSOR, FORWARD/REVERSE
- 7 CONTROL, L. HAND
- 8 OVERRIDE, RELEASE
- 9 SWITCH, HAND BRAKE
- 10 SWITCH, KEY
- 11 CONNECTOR, REAR ACC.
- 12 TAILLIGHT
- 13 COIL, IGNITION FRONT
- 14 COIL, IGNITION REAR
- 15 CAPACITOR
- 16 CDI
- 17 CONTROLLER, ACTUATOR
- 18 RELAY, STARTER
- 19 BATTERY, 12V
- 20 MOTOR, STARTER
- 21 GROUND
- 22 PUMP, FUEL/SENSOR, LEVEL
- 23 SENSOR, TILT
- 24 SENSOR, CRANK-ANGLE
- 25 REGULATOR/RECTIFIER
- 26 MAGNETO
- 27 ACTUATOR, ENG. BRAKE
- 28 CONNECTOR, SWITCH ACC.
- 29 PDM
- 30 POWER DISTRIBUTION MODULE
- 31 RESET B, BELT FAILURE
- 32 CONNECTOR, RESET
- 33 SWITCH, BELT FAILURE
- 34 SWITCH, FOOT BRAKE
- 35 SWITCH, WATER TEMP.
- 36 SWITCH, TEMP.
- 37 MOTOR, FAN
- 38 DIODE, FAN
- 39 ACTUATOR, 2WD/4WD SELECT
- 40 SWITCH, DIFF. LOCK 4WD
- 41 SWITCH, REVERSE
- 42 HEADLIGHT, L. LOW-BEAM
- 43 HEADLIGHT, L. HI-BEAM
- 44 CONNECTORS, FRONT ACC.
- 45 HEADLIGHT, R. LOW-BEAM
- 46 HEADLIGHT, R. HI-BEAM

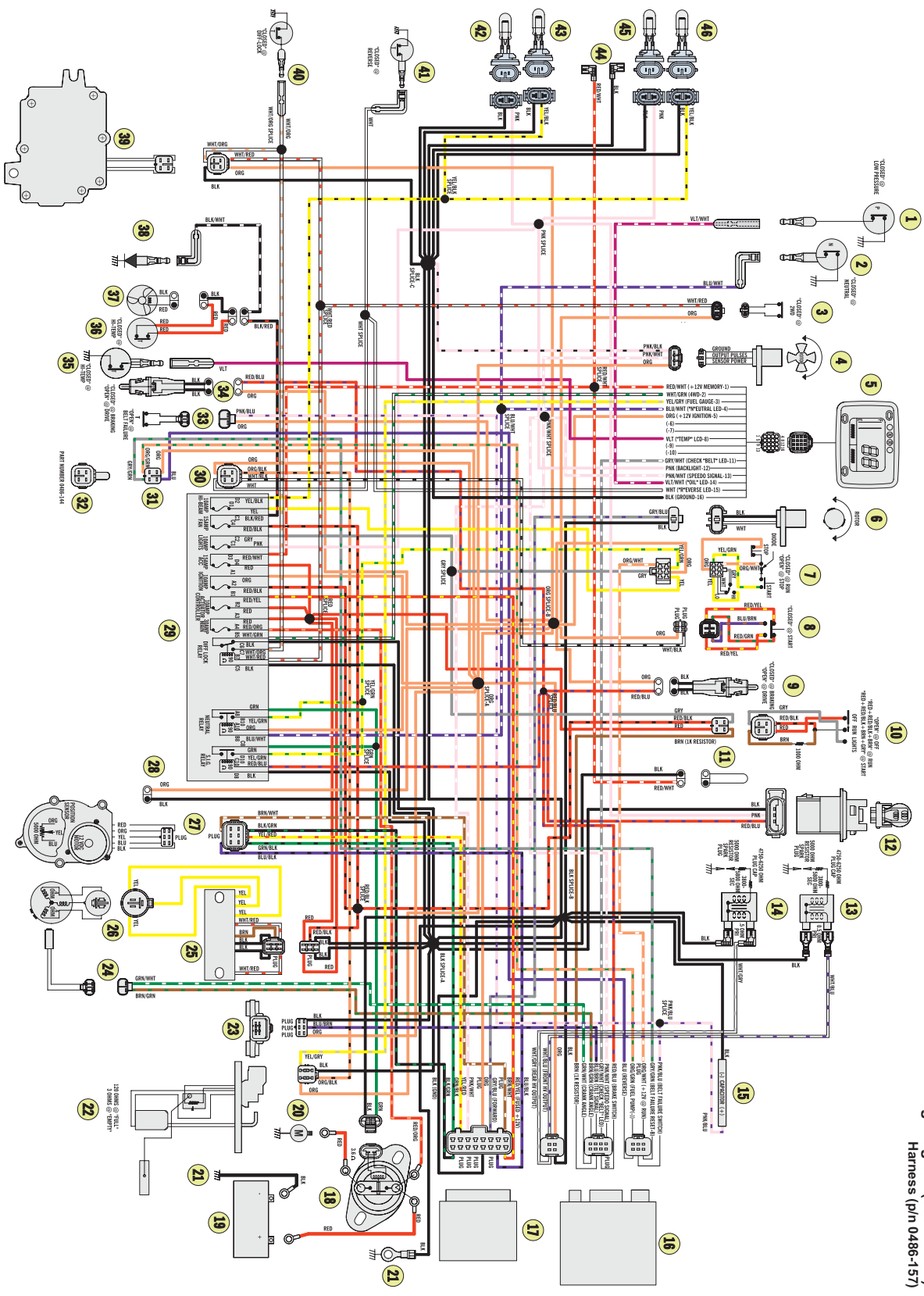

Wiring Diagram (650 V-Twin)  
Harness (p/n 0486-157)